

SPICER®



J300P-5

January 2016

Supersedes Section 5

Dated November 2012

Driveline Components Catalog Center Yokes, Tube Yokes and Ball Stud Tube Yokes



Product pictured is intended to be a representation of product category.

This publication contains data on Spicer center yokes and ball stud tube yokes for double cardan driveshafts and Spicer tube yokes for single cardan driveshafts.

HOW TO IDENTIFY A CENTER YOKE USING THIS CATALOG

To identify any center yoke, three pieces of information are required:

1. Determine the Series
2. Determine the dimension between center of U-Joint to center of U-Joint
3. Determine the type of part (circular or rectangular)

Example: To find a 1310 Series rectangular type, with a center to center dimension of 2.75, see the following example:

1. Find the 1310 Series heading
2. Find the Center to Center dimension of 2.750
3. Find a type 1 (circular is type 2, rectangular is type 1)

Order Spicer Center Yoke Part Number 2-26-177

Be sure to read any notes that are provided.

Series and all pertinent series dimensions appear as shown in the sample below:

①	C	Swing Diameter		Type	Center Yoke
	Center to Center				
	1310 SERIES	E-3.469	D-1.062	USE KIT 5-153X, 5-785X, 5-810X, 5-786X	
	2.688		3.875	2	2-26-477
	2.688		3.875	2	2-26-497
	2.688		3.875	2	2-26-507
	② 2.750		3.875	③ 1	Lube hole thru web 2-26-177
	3.000		3.875	1	2-26-257

HOW TO IDENTIFY A TUBE YOKE USING THIS CATALOG

To identify any tube yoke, three pieces of information are required:

1. Determine Series
2. Determine the size and wall thickness of the tube it fits
3. Determine the dimension from center of joint to weld point

Example: To find a 1330 Series with a 2.000 center to weld dimension, that fits a 2.750 OD tube with a .065 wall thickness, see the following example:

1. Find the 1330 Series heading
2. Find the 2.750 Tubing Diameter and .065 wall thickness (2.750 x .065 - S=Seamless, W=Welded)
3. Find the 2.000 Center to Weld dimension

Be sure to read any notes that are provided. Order Spicer Tube Yoke Part Number 5004393

Series and all pertinent series dimensions appear as shown in the sample below:

①	For Use With Tube Diameter & Wall	F	H	Used in Tube Yoke & Yoke Assembly	Tube Yoke Part Number
		Butt Diameter	C-line to Point of Weld		
	1330 SERIES	E-3.875	D-1.062	USE KIT 5-213X, 5-790X, 5-812X, 5-791X	
	2.000 X.120W	1.766	2.120		2-28-2777
	2.500 X.083W	2.344	1.719		2-28-1707
	2.500 X.083W	2.344	2.537		2-28-3347•
	② 2.750 X.065S	2.625	③ 2.000		5004393
	2.750 X.065W	2.625	2.540		5002395
	2.750 X.083S	2.594	2.030		2-28-3937



HOW TO IDENTIFY A BALL STUD TUBE YOKE USING THIS CATALOG

To identify any tube yoke, the following information is required:

1. Determine the Series
2. Determine the size and wall thickness of the tube it fits
3. Determine the dimension from center of joint to weld point
4. Determine the center of the joint to the end of the ball stud dimension
5. Determine the diameter of the ball stud
6. Determine the length of the ball stud
7. Determine the configuration and dimensions of the slinger or seal (if the part has a slinger or seal)

Example: To find a 1310 Series ball stud tube yoke with a 1.440 center to weld dimension, that fits a 2.000 OD tube with a .120 wall thickness and a .594 diameter ball stud, see the following example:

1. Find the 1310 Series heading
2. Find the 2.000 Tubing Diameter and .120 wall thickness (2.000 x .120W)
3. Find the 1.440 Center to Weld dimension
4. Find the 1.641 Center to End of Ball Stud dimension
5. Find the .594 Ball Stud Length
6. Refer to the slinger and seal illustrations on page 13 to determine which seal/slinger configuration you have.

If you have a seal, order Spicer ball stud tube yoke assembly part number 2-28-2867X

If you have a slinger, order Spicer ball stud tube yoke assembly part number 2-28-2947X

Be sure to read any notes that are provided.

Series and all pertinent series dimensions appear as shown in the sample below:

① For Use With Tube Diameter & Wall Thickness	F	K	J	Ball Stud		Slinger/Seal	Ball Stud Tube Yoke Assembly Part Number
	Butt Diameter	Centerline to Point of Weld	Centerline to End of Ball Stud	L Length	H Diameter		
1310 SERIES	E-3.469	D-1.062		USE KIT 5-153X, 5-785X, 5-810X, 5-786X			
1.250 X.120 W	1.016	1.500	1.641	.594	.500	231864	2-28-2997X
1.750 X.095 W	1.562	1.440	1.641	.594	.500	2-86-418	2-28-2827X
1.750 X.095 W	1.562	1.440	1.641	.594	.500	231864	2-28-2937X
② 2.000 X.120 W	1.766	③ 1.440	④ 1.641	⑤ .594	.500	⑥ 2-86-418	2-28-2867X
2.000 X.120 W	1.766	1.440	1.641	.594	.500	231864	2-28-2947X
2.500 X.065 W	2.375	1.440	1.641	.594	.500	2-86-418	2-28-3087X

Footnotes for parts and assemblies that are discontinued, will be discontinued upon depletion of stock, or not sold separately, are indicated by a symbol next to the part number. Match the symbol to the appropriate status at the bottom of the page. All other footnotes are located immediately below the yoke dimensional data.

IMPORTANT NOTICE: The data listed herein is correct to the best of our knowledge and belief; having been compiled from reliable and official sources of information. However, WE CANNOT ASSUME ANY RESPONSIBILITY for possible error.



CENTER YOKES

Snap Ring Design

J300P-5

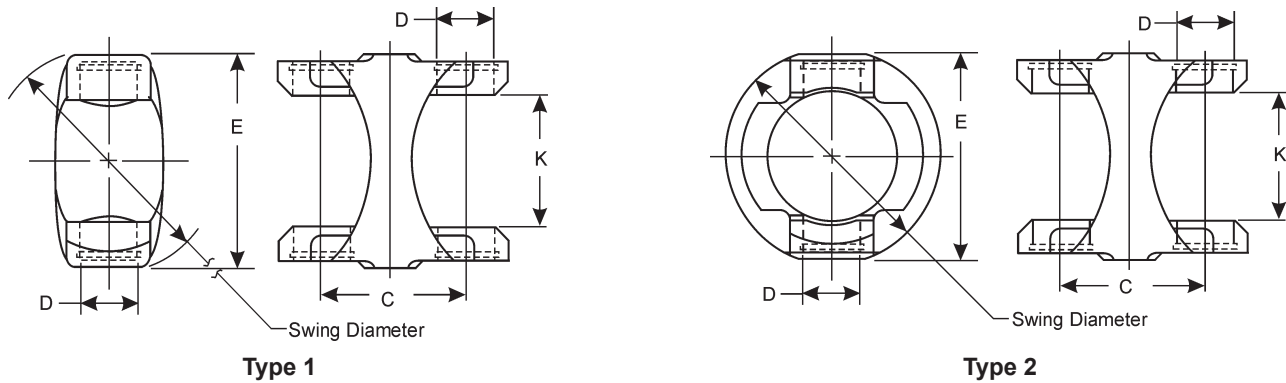

C Center to Center	Swing Diameter	Type	Center Yoke
1000 SERIES	K-1.500 D-.938		USE KIT 5-170X, 5-170-1X
2.125	2.500	2	10-26-47
1210 SERIES	E=2.688 D=1.062		USE KIT NO. 5-443X, 5-554X
2.688	3.375	2	2-26-457
1310 SERIES	E=3.469 (UB,BS STYLE E=3.219) D=1.062,		USE KIT 5-153X, 5-1310X
2.688	3.875	2	2-26-477
2.688	3.875	2	2-26-497
2.688	3.875	2	2-26-507 <i>Lube hole thru web</i>
2.750	3.875	1	2-26-177
3.000	3.875	1	2-26-257
1330 SERIES	E=3.875 (UB,BS STYLE E=3.625) D=1.062		USE KIT 5-213X, 5-1330X
2.750	4.250	2	2-26-527
2.751	4.250	2	2-26-557•
2.766	4.250	2	2-26-467
1350 SERIES	E=3.875 (UB,BS STYLE E=3.625) D=1.188		USE KIT 5-178X, 5-1350X
2.120	—	1	3-26-577•
2.750	4.250	1	3-26-317
2.875	4.682	2	3-26-757
1410 SERIES	E=4.438 (UB,BS STYLE E=4.188) D=1.188		USE KIT 5-160X, 5-1410X
3.375	4.688	1	3-26-717
1480 SERIES	E=4.438 (UB,BS STYLE E=4.188) D=1.375		USE KIT 5-188X, SPL55X
3.375	3.875	1	3-26-667
4.240	3.875	1	3-26-677
1550 SERIES	E=5.250 (UB,BS STYLE E=4.964) D=1.375		USE KIT 5-155X, SPL70X
3.938	4.125	1	4-26-437•
1610 SERIES	E=5.312 (HR STYLE E=5.312) D= 1.875		USE KIT 5-279X, 5-674X
4.576	—	1	5003513
1710 SERIES	E=6.094 (HR STYLE=6.190) D=1.938		USE KIT NO. 5-280X, 5-675X
4.606	—	1	6-26-637M

• Part is discontinued ■ Part is available until supply is exhausted ▲ Not sold separately



TUBE YOKES

Spicer Life Series™

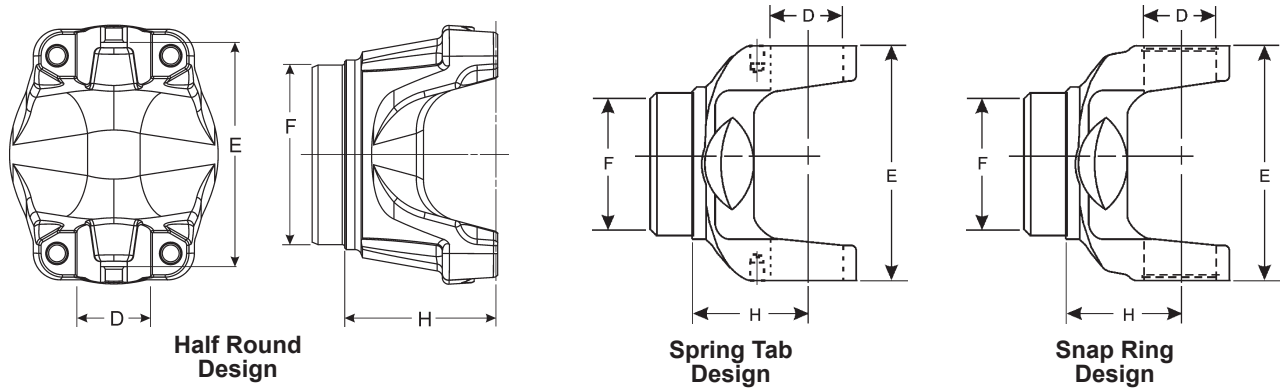

For Use With Tube Diameter & Wall	F	H	Design	Used in Tube Yoke & Yoke Assembly	Tube Yoke Part Number
	Butt Diameter	C-line to Point of Weld			
SPL55 SERIES	E=4.438 (UB,BS STYLE E=4.188) D=1.375			USE KIT SPL55X, SPL55-1X	
USE STRAP ASSY 3-70-38X					
3.500 X.083 W	3.334	2.834	HR		55-28-27
SPL70 SERIES	E=5.250 (HR STYLE E=4.965) D=1.375			USE KIT 5-155X, SPL70X	
USE STRAP ASSY 3-70-38X					
3.500 X.095 W	3.321	2.875	HR		70-28-27
SPL90 SERIES	E=5.375 (HR STYLE E=4.958) D=1.625			USE KIT NO. SPL100-1X	
4.000 X.095 W	3.812	2.969	SR		90-28-17
4.000 X.134 W	3.743	2.969	SR		90-28-27
SPL100 SERIES	E=5.375 (HR STYLE E=4.957) D=1.625			USE KIT NO. SPL100-1X	
4.000 X.095 W	3.810	2.969	SR		100-28-17
4.000 X.095 W	3.810	3.240	HR		100-28-27
				<i>For HR style use strap kit part no. 90-70-18X</i>	
SPL140 SERIES	E=5.028 (HR STYLE E=5.457) D=1.938			USE KIT SPL140X	
USE SPRING TAB KIT NO. 211941X					
4.331 X.197 W	3.957	3.504	ST		140-28-17
4.560 X.165 W	4.245	3.504	ST		140-28-27
				<i>Also fits 4.213 x .138 wall tube</i>	
SPL170 SERIES	E=6.026 (HR STYLE E=6.456) D=2.166			USE KIT SPL170-4X, SPL170-SF4X	
USE SPRING TAB KIT NO. 211941X					
—	4.112	4.567	ST		170-28-13415
				<i>Tube yoke presses into splined sleeve</i>	
—	4.112	4.567	ST		5013415
				<i>5013415 was replaced by 170-28-13415; Tube yoke presses into splined sleeve</i>	
—	4.350	4.724	ST		170-28-37
				<i>Tube yoke presses into splined sleeve</i>	
4.500 X.134 W	4.242	4.567	ST		170-28-09269
4.500 X.134 W	4.242	4.567	ST		5009269
				<i>5009269 was replaced by 170-28-09269</i>	
4.724 X.197 W	4.350	4.724	ST		170-28-27
4.961 X.118 W	4.746	3.700	ST		170-28-17
SPL250 SERIES	E=5.986 (HR STYLE E=6.417) D=2.362			USE KIT SPL250-3X, SPL250-SF3X	
USE SPRING TAB KIT NO. 211941X					
—	4.423	4.882	ST		250-28-37
				<i>Tube yoke presses into splined sleeve</i>	
5.197 X.236 W	4.746	4.094	ST		250-28-17

• Part is discontinued ■ Part is available until supply is exhausted ▲ Not sold separately



Important: See Safety Information in General Information Section (J300P-GI)

TUBE YOKES

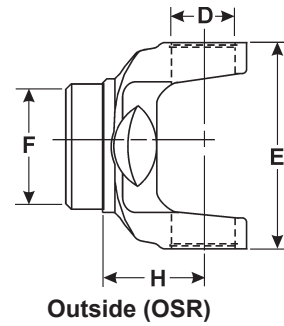
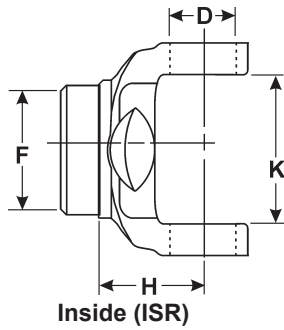

For Use With Tube Diameter & Wall	F		Used in Tube Yoke & Yoke Assembly	Tube Yoke Part Number
	Butt Diameter	H C-line to Point of Weld		
1000 SERIES	K-1.500	D-.938	USE KIT 5-170X, 5-170-1X	
1.250 X.095 W	1.068	2.560		10-26-37
1.750 X.065 W	1.625	2.000	10-27-1	10-28-17 <i>10-28-17 was replaced by 10-28-97</i>
1.750 X.065 W	1.631	2.000		10-28-97
1100 SERIES	E=2.656	D=.938	USE KIT 5-101X OR 5-111X	
1.250 X.095 W	1.068	1.688		1-26-297
2.000 X.065 W	1.881	1.500		1-28-107•
1210 SERIES	E=2.688	D=1.062	USE KIT NO. 5-443X, 5-554X	
1.500 X.120 W	1.267	1.625		2-28-3027•
2.000 X.083 W	1.845	1.500		2-28-2417
2.500 X.065 W	2.381	1.312		2-28-1947
1310 SERIES	E=3.469 (UB,BS E=3.219)	D=1.062,	USE KIT 5-153X,5-1310X,5-1310-1X	
1.250 X.095 W	1.068	2.125		2-26-187
1.250 X.120 S	1.016	2.125		2-26-347
1.250 X.188 S	.886	2.281		2-26-147
1.750 X.065 W	1.630	1.688		2-28-447
1.750 X.095 W	1.571	1.688		2-28-3187
2.000 X.065 W	1.881	1.688		2-28-417
2.000 X.083 W	1.845	1.688	2-27-7	2-28-357
2.000 X.095 W	1.821	1.688		2-28-577
2.000 X.120 W	1.771	1.688		2-28-1757
2.000 X.120 W	1.771	1.965		2-28-02324
2.000 X.120 W	1.771	1.965		5002324
			<i>5002324 was replaced by 2-28-02324</i>	
2.250 X.095 W	2.062	2.000		2-28-547•
2.500 X.065 W	2.381	1.844	2-27-4	2-28-277
2.500 X.083 W	2.345	1.844	2-27-9	2-28-367
2.750 X.065 W	2.631	1.688	2-27-5	2-28-307
2.750 X.083 W	2.595	1.688		2-28-1617•
3.000 X.065 W	2.881	1.688	2-27-6	2-28-327
3.000 X.065 W	2.881	1.844		2-28-3207
3.000 X.083 W	2.845	1.688	2-27-24	2-28-437
3.250 X.065 W	3.130	1.688		2-28-557
3.500 X.065 W	3.381	1.688	2-27-10	2-28-397
3.500 X.083 W	3.345	1.688	2-27-12	2-28-427
4.000 X.083 W	3.844	1.500		2-28-477
4.000 X.083 W	3.845	1.906		2-28-3837•
1330 SERIES	E=3.875 (UB,BS E=3.625)	D=1.062	USE KIT 5-213X,5-1330X,5-1330-1X	
2.000 X.120 W	1.771	2.125		2-28-2777
2.500 X.083 W	2.345	1.719		2-28-1707
2.500 X.083 W	2.344	2.537		2-28-3347•
2.750 X.065 S	2.631	2.000		5004393•

• Part is discontinued ■ Part is available until supply is exhausted ▲ Not sold separately





For Use With Tube Diameter & Wall	F	H	Used in Tube Yoke & Yoke Assembly	Tube Yoke Part Number
	Butt Diameter	C-line to Point of Weld		
1330 SERIES (Cont'd) E=3.875 (UB,BS E=3.625) D=1.062 USE KIT 5-213X,5-1330X,5-1330-1X				
2.750 X.065 W	2.625	2.540		5002395•
2.750 X.083 S	2.595	2.031		2-28-3937
2.750 X.083 W	2.591	2.539		2-28-4017
3.000 X.065 W	2.881	1.719		2-28-1177
3.000 X.083 W	2.845	1.719		2-28-1697
3.000 X.083 W	2.844	2.240		2-28-06030
3.000 X.083 W	2.844	2.240		5006030
				<i>5006030 was replaced by 2-28-06030</i>
3.500 X.065 W	3.381	1.812		2-28-1977
3.500 X.065 W	3.370	2.413		5002389•
3.500 X.083 W	2.345	1.812		2-28-1717
4.000 X.065 W	3.884	1.690		2-28-3787
4.000 X.065 W	3.884	2.220		2-28-12027
4.000 X.065 W	3.884	2.220		5012027
				<i>5012027 was replaced by 2-28-12027</i>
4.000 X.083 W	3.844	1.688		2-28-1967
1350 SERIES E=3.875 (UB,BS E=3.625) D=1.188 USE KIT 5-178X, 5-1350X, 5-1310-1X				
2.000 X.120 W	1.771	2.125		3-28-777
2.500 X.083 W	2.345	1.938	3-27-1	3-28-47
2.750 X.065 W	2.631	2.031		3-28-1107•
3.000 X.065 W	2.881	2.030		3-28-137
3.000 X.083 W	2.845	2.000	3-27-2	3-28-57
3.000 X.083 W	2.844	2.031		3-28-1157
				<i>3-28-1157 was replaced by 3-28-57</i>
3.000 X.095 W	2.821	2.000		3-28-157
3.000 X.134 W	2.734	1.970		3-28-1137•
3.500 X.065 W	3.381	1.812	3-27-5	3-28-257
3.500 X.083 W	3.345	1.840		3-28-427
4.000 X.065 W	3.881	2.220		5006456
				<i>5006456 was replaced by 2-28-06456</i>
4.000 X.065 W	3.884	1.690		3-28-1667
4.000 X.065 W	3.881	2.220		3-28-06456▲
4.000 X.083 W	3.844	1.688		3-28-417
1410 SERIES E=4.438 (UB,BS E=4.188) D=1.188 USE KIT 5-160X, 5-1410X,5-1410-1X				
2.000 X.120 W	1.771	2.000		3-26-117
2.500 X.095 W	2.321	2.000		3-28-327
2.500 X.156 S	2.217	2.000		3-26-437
2.750 X.083 W	2.595	1.625		3-28-987
3.000 X.083 W	2.845	1.625		3-28-447
3.000 X.083 W	2.845	2.125	3-27-3	3-28-97
3.000 X.095 W	2.821	2.125	3-27-6	3-28-267
3.000 X.134 W	2.742	1.624		3-28-997•
3.000 X.250 W	2.500	1.625		3-28-1117•
3.500 X.065 W	3.381	2.125	3-27-8	3-28-367
3.500 X.083 W	3.345	2.125	3-27-4	3-28-557
3.500 X.095 W	3.321	2.125		3-28-857•
4.000 X.065 W	3.884	1.880		3-28-1267•
4.000 X.083 W	3.845	1.875	3-27-16	3-28-457
4.000 X.095 W	3.821	1.875		3-28-387
4.095 X.180 W	3.743	2.030		3-28-1087•

• Part is discontinued ■ Part is available until supply is exhausted ▲ Not sold separately



Important: See Safety Information in General Information Section (J300P-GI)

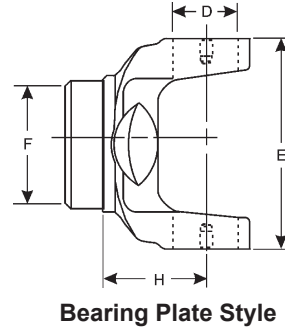
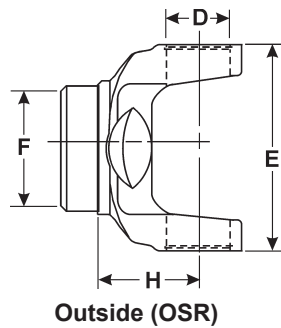

For Use With Tube Diameter & Wall	F	H	Used in Tube Yoke & Yoke Assembly	Tube Yoke Part Number
	Butt Diameter	C-line to Point of Weld		
1480 SERIES	E=4.438 (UB,BS E=4.188) D=1.375		USE KIT 5-188X, SPL55X, SPL55-1X	
3.000 X.095 W	2.821	1.688		3-28-497
3.500 X.083 W	3.345	2.031	3-27-22	3-28-537
3.500 X.083 W	3.345	2.312		3-28-547
3.500 X.095 W	3.321	2.031		3-28-567
4.000 X.083 W	3.845	2.031	3-27-20	3-28-507
4.000 X.095 W	3.821	2.031		3-28-627
1550 SERIES	E=5.250 (UB,BS E=4.964) D=1.375		USE KIT 5-155X, SPL70X, SPL70-1X	
3.500 X.095 W	3.321	1.844		4-28-257
3.500 X.095 W	3.321	2.188	4-27-18	4-28-307
3.500 X.095 W	3.321	2.688	4-27-16	4-28-417
3.500 X.095 W	3.321	3.125		4-28-427•
3.500 X.134 W	3.243	1.810		4-28-627
3.500 X.134 W	3.243	2.188		4-28-487
3.500 X.156 W	3.199	2.188		4-28-657
4.000 X.083 W	3.845	2.188		4-28-277
4.000 X.095 W	3.812	2.188		4-28-297•
1610 SERIES	E=5.312 (HR STYLE E=5.312) D= 1.875		USE KIT 5-279X, 5-674X	
3.500 X.095 W	3.320	3.000	5-27-7	5-28-167
3.500 X.134 W	3.243	3.000	5-27-25	5-28-627
3.500 X.134 W	3.250	3.000		5-28-717•
3.500 X.134 W	3.243	3.810		5-28-887
				<i>High angle yoke</i>
3.500 X.156 W	3.199	3.000	5-27-9	5-28-207
3.500 X.156 W	3.263	3.000		5-28-957
3.550 X.207 W	3.141	2.220		5-28-837•
3.550 X.207 W	3.153	2.220		5-28-977M
				<i>Metric bolt holes; uses 5-585XM u-joint</i>
3.550 X.207 W	3.141	3.000		5-28-967•
4.000 X.134 W	3.743	3.000		5-28-327
1710 SERIES	E=6.094 (HR STYLE=6.190) D=1.938		USE KIT NO. 5-280X, 5-675X	
3.500 X.156 W	3.198	3.031	6-27-7	6-28-137
4.000 X.134 W	3.743	3.031	6-27-17	6-28-347
4.000 X.134 W	3.743	3.031		6-28-557M
4.000 X.134 W	3.743	3.688		6-28-467
				<i>High angle yoke</i>
4.000 X.134 W	3.743	4.060		6-28-527
4.500 X.134 W	4.242	3.031		6-28-407
1760 SERIES	E=7.000 (HR STYLE=7.094) D=1.938		USE KIT NO. 5-407X, 5-677X	
4.095 X.180 W	3.743	3.031		6.3-28-17
1810 SERIES	E=7.547 (HR STYLE=7.643) D=1.938		USE KIT NO. 5-281X, 5-676X	
4.500 X.134 W	4.243	3.375	6.5-27-9	6.5-28-117
4.500 X.259 W	4.003	3.375		6.5-28-127

• Part is discontinued ■ Part is available until supply is exhausted ▲ Not sold separately



For Use With Tube Diameter & Wall	F		H	Used in Tube Yoke & Yoke Assembly	Tube Yoke Part Number
	Butt Diameter		C-line to Point of Weld		
1880 SERIES	E=8.094	D=2.188	USE KIT 5-308X		
4.500 X.259 W	4.003		4.000		8-28-147
1950 SERIES	E=10.094	D=3.062	USE KIT 5-192X		
6.000 X.500 S	5.125		6.531		9-26-18X•
5C SERIES	P=4.531	S=1.685	KEYWAY-.562	USE KIT 5-5111X	
2.500 X.159 W	2.186		2.224		5C-28-27• .375-24 Threaded Holes
6C SERIES	P=5.531	S=1.689	KEYWAY-.562	USE KIT 5-6111X	
2.756 X.159 W	2.448		1.870		6C-28-27• .375-24 Threaded Holes

• Part is discontinued ■ Part is available until supply is exhausted ▲ Not sold separately



Important: See Safety Information in General Information Section (J300P-GI)

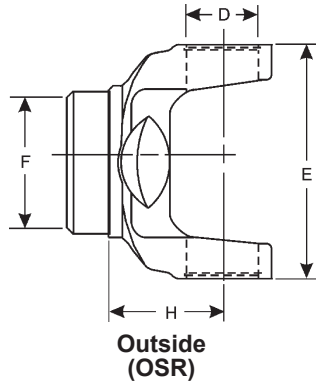

For Use With Tube Diameter & Wall	F	H	Used in Tube Yoke & Yoke Assembly	Tube Yoke Part Number
	Butt Diameter	C-line to Point of Weld		
1310 SERIES	E=3.469 D=1.062	USE KIT 5-3613X		
2.750 X.120 S	2.531	1.375		2-28-2787•
3.000 X.120 S	2.782	1.375		2-28-2427
3.250 X.083 S	3.104	1.969		2-28-3367•
3.750 X.083 S	3.604	2.130		2-28-3717•
4.000 X.083 S	3.855	2.125		2-28-3637•
4.000 X.083 S	3.853	2.130		2-28-3697•
1330 SERIES	E=3.875 D=1.062	USE KIT 5-3614X		
3.500 X.081 W	3.355	1.839		2-28-4047•
3.500 X.083 W	3.355	1.840		2-28-3767
3.500 X.120 S	3.280	1.837		2-28-2757•
4.000 X.083 S	3.855	2.125		2-28-3317
4.000 X.083 S	3.855	2.232	<i>Use plug no. 232639 in vent hole</i>	2-28-16881
				<i>w/vent hole thru web</i>
4.000 X.083 S	3.855	2.232		2-28-16882
4.000 X.083 S	3.855	2.232		5016881
			<i>5016881 was replaced by 2-28-16881; w/vent hole thru web</i>	5016882
4.000 X.083 S	3.855	2.232	<i>5016882 will be replaced by 2-28-16882 when supply is exhausted</i>	5016882
4.000 X.083 S	3.855	2.406		2-28-3327
4.000 X.083 S	3.855	3.130		2-28-3377
4.000 X.083 W	3.844	2.130		2-28-4057•
4.160 X.086 S	3.998	2.130		2-28-3687
4.160 X.086 S	3.998	2.406		2-28-3517
4.506 X.098 W	4.388	2.205		2-28-01588
4.506 X.098 W	4.388	2.205		5001588
4.520 X.075 S	4.388	2.130		2-28-3507
			<i>Use plug no. 232639 in vent hole</i>	2-28-01484
4.540 X.083 S	4.388	4.000		5001484
4.540 X.083 S	4.388	4.000	<i>5001484 was replaced by 2-28-01484</i>	2-28-3487
5.000 X.065 S	4.888	1.820		2-28-3487
5.000 X.065 S	4.888	4.110		2-28-3527

• Part is discontinued ■ Part is available until supply is exhausted ▲ Not sold separately



For Use With Tube Diameter & Wall	F		H	Used in Tube Yoke & Yoke Assembly	Tube Yoke Part Number
	Butt Diameter	D	C-line to Point of Weld		
1350 SERIES	E=3.875	D=1.188	USE KIT 5-3615X		
3.500 X.120 S	3.280		1.837		3-28-977
3.500 X.165 S	3.188		1.837		3-28-1197
4.000 X.083 S	3.855		2.125		3-28-1297
4.000 X.083 S	3.855		2.406		3-28-1307
4.160 X.086 S	3.998		2.130		3-28-1617
4.160 X.086 S	3.998		2.232		3-28-16885
					<i>w/vent hole thru web</i>
4.160 X.086 S	3.998		2.232		5016885
					<i>w/vent hole thru web</i>
4.160 X.086 S	3.998		2.410		3-28-1437•
4.500 X.065 S	4.388		4.000		3-28-10274
4.500 X.065 S	4.388		4.000		5010274
					<i>5010274 was replaced by 3-28-10274</i>
4.500 X.095 S	4.325		3.173		5006297•
4.500 X.095 W	4.325		3.173		3-28-07154
					<i>OPTIONAL TUBE: 4.574 X .134</i>
4.500 X.095 W	4.325		3.173		5007154
					<i>5007154 was replaced by 3-28-07154; w/vent hole thru web</i>
4.520 X.075 S	4.388		2.130		3-28-1407
5.000 X.065 S	4.888		1.840		3-28-01701•
5.000 X.065 S	4.888		1.840		5001701•
5.000 X.065 S	4.888		1.844		3-28-1347
5.000 X.065 S	4.888		4.110		3-28-1447
5.090 X.107 S	4.876		3.173		3-28-06301
					<i>w/vent hole thru web</i>
5.090 X.107 S	4.888		3.173		3-28-07058
5.090 X.107 S	4.888		3.173		3-28-12681
5.090 X.107 S	4.876		3.173		5006301
					<i>5006301 was replaced by 3-28-06301; w/vent hole thru web</i>
5.090 X.107 S	4.888		3.173		5007058
					<i>5007058 was replaced by 3-28-07058</i>
5.090 X.107 S	4.888		3.173		5012681
1410 SERIES	E=4.438	D=1.188	USE KIT 5-3616X		
4.000 X.083 S	3.853		2.290		3-28-1607•
4.000 X.083 W	3.855		2.130		3-28-03535
4.000 X.083 W	3.855		2.130		3-28-03536
4.000 X.083 W	3.855		2.130		5003535
					<i>5003535 was replaced by 3-28-03535; Use plug no. 232639 in vent hole</i>
4.000 X.083 W	3.855		2.130		5003536
					<i>5003536 was replaced by 3-28-03536</i>
4.000 X.103 S	3.812		2.125		3-28-1537•
4.157 X.087 S	3.998		2.290		3-28-1757
4.506 X.098 S	4.325		2.125		3-28-1387•
4.510 X.063 S	4.384		2.290		3-28-1547•
					<i>Use plug no. 232639 in vent hole</i>
4.510 X.063 S	4.384		2.290		3-28-1597•
5.000 X.063 S	4.888		2.281		3-28-1647
5.000 X.065 S	4.888		4.109		3-28-1657

• Part is discontinued ■ Part is available until supply is exhausted ▲ Not sold separately



Important: See Safety Information in General Information Section (J300P-GI)

BALL STUD TUBE YOKES

For Constant Velocity Applications

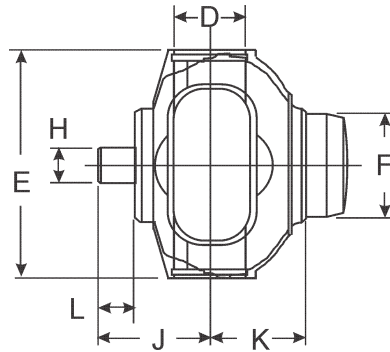

For Use With Tube Diameter & Wall Thickness	F	K	J	Ball Stud		Slinger	Ball Stud Tube Yoke Assembly Part Number
	Butt Diameter	Centerline to Point of Weld	Centerline to End of Ball Stud	L Length	H Diameter		
1210 SERIES	E=2.688 D=1.062 USE KIT NO. 5-443X, 5-554X						
2.500 X.065 W	2.375	1.310	1.641	.594	.500	231413	2-28-2407X
2.500 X.083 W	2.334	1.310	1.640	.594	.500	231413	2-28-3657X
1310 SERIES	E=3.469 (UB,BS STYLE E=3.219) D=1.062, USE KIT 5-153X, 5-1310X						
1.250 X.120 W	1.016	1.500	1.641	.594	.500	231864	2-28-2997X
1.750 X.095 W	1.562	1.440	1.641	.594	.500	231864	2-28-2937X
1.750 X.095 W	1.562	1.440	1.641	.594	.500	2-86-418	2-28-2827X
2.000 X.120 W	1.766	1.438	1.641	.594	.500		2-28-2857
2.000 X.120 W	1.766	1.440	1.641	.594	.500	231864	2-28-2947X
2.000 X.120 W	1.766	1.440	1.641	.594	.500	2-86-418	2-28-2867X
2.500 X.065 W	2.375	1.440	1.641	.594	.500	2-86-418	2-28-3087X
2.500 X.083 W	2.344	1.440	1.641	.594	.500	2-86-418	2-28-2887X
2.500 X.083 W	2.344	1.440	1.641	.594	.500	231864	2-28-2957X
2.750 X.065 W	2.625	1.281	1.641	.594	.500	231864	2-28-2987X
2.750 X.065 W	2.625	1.281	1.641	.594	.500	2-86-418	2-28-2747X
2.750 X.083 W	2.584	1.440	1.641	.594	.500	231864	2-28-3817X*
3.000 X.065 W	2.875	1.440	1.641	.594	.500	231864	2-28-2967X
3.000 X.065 W	2.875	1.440	1.641	.594	.500	2-86-418	2-28-2907X
3.000 X.083 W	2.844	1.440	1.641	.594	.500	2-86-418	2-28-2927X
3.000 X.083 W	2.844	1.440	1.641	.594	.500	231864	2-28-2977X
1330 SERIES	E=3.875 (UB,BS STYLE E=3.625) D=1.062 USE KIT 5-213X, 5-1330X						
2.000 X.120 W	1.766	1.375	1.670	.590	.500	2-86-418	2-28-3257X
2.000 X.120 W	1.766	1.375	1.670	.590	.500	231259	2-28-2157X
2.500 X.083 W	2.344	1.375	1.670	.590	.500	231259	2-28-2137X
2.500 X.083 W	2.344	1.375	1.670	.590	.500	2-86-418	2-28-3067X
2.500 X.095 W	2.312	1.375	1.670	.590	.500	2-86-418	2-28-3277X*
3.000 X.065 W	2.875	1.440	1.670	.422	.500	231259	2-28-2117X
3.000 X.083 W	2.844	1.375	1.670	.590	.500	2-86-418	2-28-3447X
3.000 X.083 W	2.844	1.440	1.670	.590	.500	231259	2-28-2187X
1350 SERIES	E=3.875 (UB,BS STYLE E=3.625) D=1.188 USE KIT 5-178X, 5-1350X						
2.750 X.083 W	2.611	1.440	1.732	.590	.500	2-86-418	3-28-1747X OEM only
3.000 X.083 W	2.844	1.440	1.732	.590	.500	2-86-418	3-28-1327X
3.000 X.083 W	2.844	1.551	1.732	.590	.500		3-28-09422X
3.000 X.083 W	2.844	1.551	1.732	.590	.500		5009422
							5009422 was replaced by 3-28-09422X
3.500 X.083 W	3.344	1.440	1.732	.590	.500	2-86-418	3-28-1527X

* Part is discontinued ■ Part is available until supply is exhausted ▲ Not sold separately



J300P-5 SOCKET YOKE ASSEMBLY DIMENSIONS

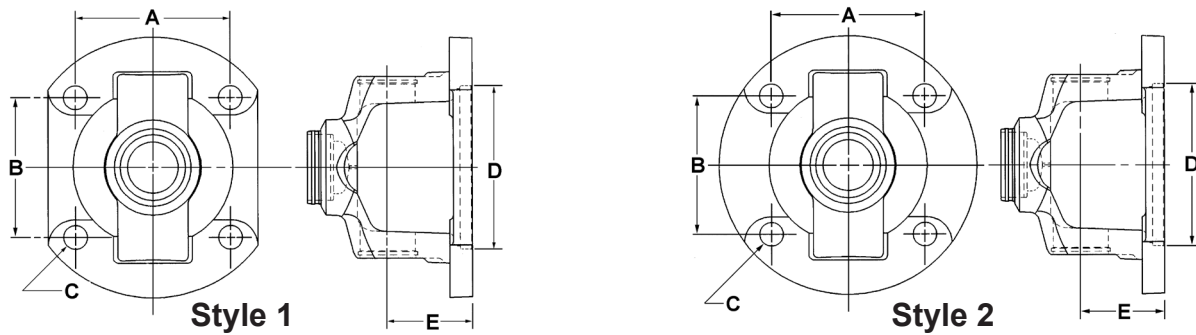

Flanged Socket Yoke Assembly	Series	Style	Bolt Circle Diameter	Bolt Holes Dimensions			Fits Diameter	C/L to End	Ball Stud Size
				A	B	C			
211489X●	1210	1	3.500	2.468	2.468	0.484	2.000	1.625	0.500
211543X■◇	1310	1	3.500	2.484	2.484	0.484	2.000	1.625	0.500
211229X■▶	1310	1	3.500	2.484	2.484	0.484	2.000	1.625	0.500
212130X■	1310	1*	3.750	2.712	2.712	0.401	2.750M	1.500	0.500
211198X●	1310	1	4.000	2.937	2.937	0.453	3.125	1.625	0.500
211452X●	1310	1	4.250	3.000	3.000	0.453	3.125	1.625	0.500
211545X■	1310	1	4.250	3.000	3.000	0.453	3.125	1.625	0.500
212040X■	1310	1	4.250	3.000	3.000	0.488	3.126	1.620	0.500
211631X■	1330	1	4.250	3.000	3.000	M12X1.75th'd	2.000	1.625	0.500
211889X●	1330	2	4.000	2.953	2.656	0.453	3.125	1.875	0.500
211606X	1330	2	4.000	2.953	2.656	0.453	3.125	1.812	0.500
211520X●	1330	2	4.000	2.953	2.656	0.453	3.125	1.875	0.625
211868X●	1330	2	4.250	3.000	3.000	0.453	3.125	1.812	0.500
211913X■	1330	1	4.250	3.000	3.000	0.462	3.125	1.625	0.500
212024X■	1350	1	4.250	3.000	3.000	M12X1.75th'd	2.000	1.625	0.500
212025X■	1350	1	4.250	3.000	3.000	M12X1.75th'd	2.680	1.625	0.500
**5009419■	1350	1	4.250	3.000	3.000	0.459	3.125	1.620	0.500

*Male Pilot

**2-12-229 spring not included

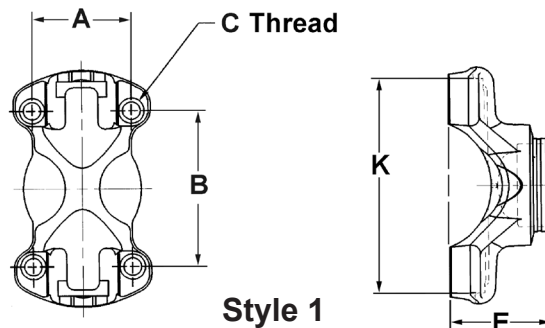

Flanged Socket Yoke Assembly	Series	Style	Bolt Circle Diameter	Bolt Holes Dimensions			C/L to End	Ball Stud Size
				A	B	C		
211342X	1210	3	2.437	1.500	2.343	.250-28th'd	1.531	0.500
211519X	1210	—	2.437	1.500	2.343	.250-28th'd	1.640	has .500 stud
211355X	1310	3	3.218	1.500	2.343	.312-24th'd	1.531	0.500
211544X■◇	1310	3	3.218	1.500	2.343	.312-24th'd	1.656	0.500
211179X●	1330	3	3.625	1.500	2.875	.312-24th'd	1.562	0.500
210841X	1330	3	3.625	1.500	2.875	.312-24th'd	1.562	0.625
211996X■◇	1330	3	3.625	1.500	2.875	.312-24th'd	1.690	0.500
212019X■	1350	3	3.625	1.625	2.750	.312-24th'd	1.757	0.500

- Flush Zerk (#230977) ▶ Socket OD 1.394
- Non-Greasable ◇ Socket OD 1.625



Important: See Safety Information in General Information Section (J300P-GI)

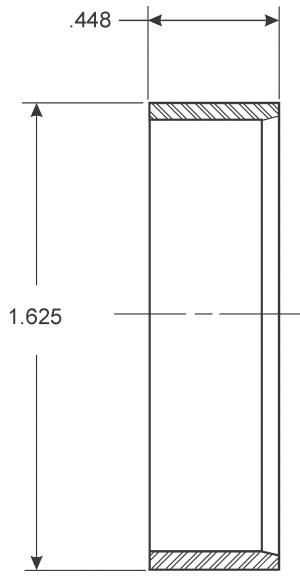

230962

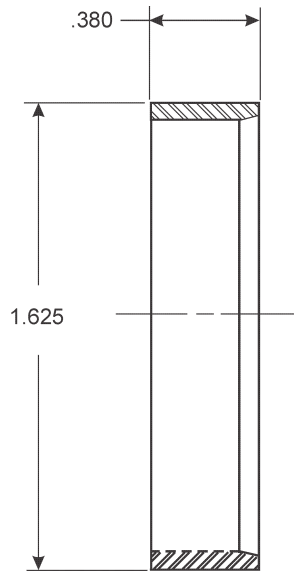

231259

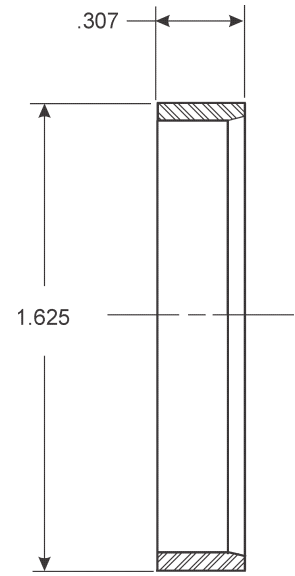

231413

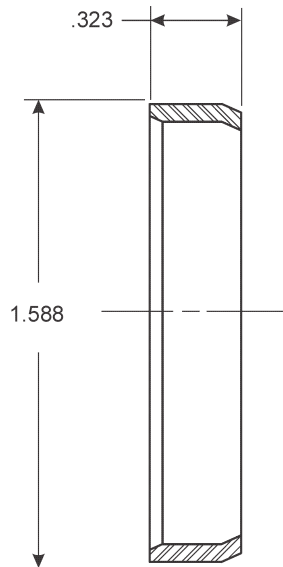

231864

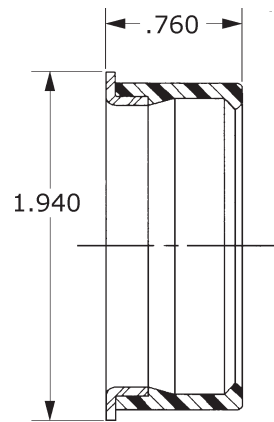

**Seal
2-86-418**



1-26-297	6	2-28-3507	10	3-28-547	8
1-28-107	6	2-28-3517	10	3-28-557	7
2-26-147	6	2-28-3527	10	3-28-567	8
2-26-177	4	2-28-3687	10	3-28-627	8
2-26-187	6	2-28-3767	10	3-28-777	7
2-26-257	4	2-28-3787	7	3-28-857	7
2-26-347	6	2-28-3837	6	3-28-977	11
2-26-457	4	2-28-3937	7	3-28-987	7
2-26-467	4	2-28-4017	7	3-28-997	7
2-26-477	4	2-28-06030	7	3-28-1087	7
2-26-497	4	2-28-12027	7	3-28-1107	7
2-26-507	4	2-28-16881	10	3-28-1117	7
2-26-527	4	2-28-16882	10	3-28-1137	7
2-26-557	4	2-28-1617S	6	3-28-1157	7
2-28-277	6	2-28-2747X	12	3-28-1197	11
2-28-307	6	2-28-2827X	12	3-28-1267	7
2-28-327	6	2-28-2867X	12	3-28-1297	11
2-28-357	6	2-28-2887X	12	3-28-1307	11
2-28-367	6	2-28-2907X	12	3-28-1347	11
2-28-397	6	2-28-2927X	12	3-28-1387	11
2-28-417	6	2-28-3067X	12	3-28-1407	11
2-28-427	6	2-28-3087X	12	3-28-1437	11
2-28-437	6	2-28-3257X	12	3-28-1447	11
2-28-447	6	2-28-3277X	12	3-28-1537	11
2-28-477	6	2-28-3447X	12	3-28-1547	11
2-28-547	6	3-26-117	7	3-28-1597	11
2-28-557	6	3-26-317	4	3-28-1607	11
2-28-577	6	3-26-437	7	3-28-1617	11
2-28-1177	7	3-26-577	4	3-28-1647	11
2-28-01484	10	3-26-667	4	3-28-1657	11
2-28-01588	10	3-26-677	4	3-28-1667	7
2-28-1697	7	3-26-717	4	3-28-01701	11
2-28-1707	6	3-26-757	4	3-28-1757	11
2-28-1717	7	3-28-47	7	3-28-03535	11
2-28-1757	6	3-28-57	7	3-28-03536	11
2-28-1947	6	3-28-97	7	3-28-06301	11
2-28-1967	7	3-28-137	7	3-28-06456	7
2-28-1977	7	3-28-157	7	3-28-07058	11
2-28-02324	6	3-28-257	7	3-28-07154	11
2-28-2417	6	3-28-267	7	3-28-10274	11
2-28-2427	10	3-28-327	7	3-28-12681	11
2-28-2777	6	3-28-367	7	3-28-16885	11
2-28-2857	12	3-28-387	7	3-28-09422X	12
2-28-3027	6	3-28-417	7	3-28-1327X	12
2-28-3187	6	3-28-427	7	3-28-1527X	12
2-28-3207	6	3-28-447	7	3-28-1747X	12
2-28-3317	10	3-28-457	7	4-26-437	4
2-28-3327	10	3-28-497	8	4-28-257	8
2-28-3377	10	3-28-507	8	4-28-277	8
2-28-3487	10	3-28-537	8	4-28-297	8

• Part is discontinued ■ Part is available until supply is exhausted ▲ Not sold separately



Important: See Safety Information in General Information Section (J300P-GI)

4-28-307	8	535871-10.....	10
4-28-417	8	634487-10.....	10
4-28-427	8	656402-10.....	10
4-28-487	8	663706-10.....	10
4-28-627	8	784236-10.....	10
4-28-657	8	787889-10.....	10
5-28-167	8	2312592-28-2117X	12
5-28-207	8	2312592-28-2137X	12
5-28-327	8	2312592-28-2157X	12
5-28-627	8	2312592-28-2187X	12
5-28-717	8	2314132-28-2407X	12
5-28-837	8	2314132-28-3657X	12
5-28-887	8	2318642-28-2937X	12
5-28-957	8	2318642-28-2947X	12
5-28-967	8	2318642-28-2957X	12
5-28-977M	8	2318642-28-2967X	12
6-26-637M	4	2318642-28-2977X	12
6-28-137	8	2318642-28-2987X	12
6-28-347	8	2318642-28-2997X	12
6-28-407	8	2318642-28-3817X	12
6-28-467	8	5001484-10.....	10
6-28-527	8	5001588-10.....	10
6-28-557M	8	5001701-11.....	11
6.3-28-17	8	5002324-6.....	6
6.5-28-117.....	8	5002389-7.....	7
6.5-28-127	8	5002395-7.....	7
8-28-147	9	5003513-4.....	4
9-26-18X.....	9	5003535-11.....	11
10-26-37	6	5003536-11.....	11
10-26-47	4	5004393-6.....	6
10-28-17	6	5006030-7.....	7
10-28-97	6	5006297-11.....	11
55-28-27	5	5006301-11.....	11
70-28-27	5	5006456-7.....	7
90-28-17	5	5007058-11.....	11
90-28-27	5	5007154-11.....	11
100-28-17	5	5009269-5.....	5
100-28-27	5	5009422-12.....	12
140-28-17	5	5010274-11.....	11
140-28-27	5	5012027-7.....	7
170-28-17	5	5012681-11.....	11
170-28-27	5	5013415-5.....	5
170-28-37	5	5016881-10.....	10
170-28-09269	5	5016882-10.....	10
170-28-13415	5	5016885-11.....	11
250-28-17	5	5C-28-27.....	9
250-28-37	5	6C-28-27.....	9
313073-10.....	10		
324030-10.....	10		
528566-6.....	6		

• Part is discontinued ■ Part is available until supply is exhausted ▲ Not sold separately



Dana Aftermarket Group

PO Box 1000
Maumee, Ohio 43537

Warehouse Distributors: 1.800.621.8084
OE Dealers: 1.877.777.5360

www.SpicerParts.com

SPICER[®]



J300P-5 Printed in U.S.A.
Copyright Dana Limited, 2016.
All rights reserved. Dana Limited.

