

SPICER®



J300P-10

November 2015

Supersedes Section 10

Dated August 2008

Driveline Components Catalog Flange & End Yoke Applications



Product pictured is intended to be a representation of product category.

Table Of Contents

Auxiliary Transmissions	
Fuller.....	6
Spicer®.....	15
Single Axles	
Axle Alliance Corporation.....	19
Clark.....	19
Fabco.....	20
Navistar / International.....	22
Mack.....	24
Oshkosh.....	24
Meritor / Rockwell.....	24
Spicer®.....	34
Chelsea Split Shaft PTOs.....	63
Tandem Axles	
Axle Alliance Corporation.....	65
Clark.....	65
Navistar / International.....	65
Mack.....	68
Oshkosh.....	78
Meritor / Rockwell.....	78
Spicer®.....	94
Main Transmissions	
Allison.....	126
Caterpillar.....	130
Clark.....	130
Fuller.....	131
Mack.....	162
New Process.....	164
Meritor / Rockwell.....	165
Spicer®.....	168
Warner.....	182
Transfer Cases	
Fabco.....	183
Mack.....	184
New Process.....	184
Oshkosh.....	185
Meritor / Rockwell.....	185
Spicer®.....	185
Companion Flange Part Data Listing.....	187
End Yoke Part Data Listing.....	188

NOTE: the data listed herein is correct to the best of our knowledge and belief; having been compiled from reliable and official sources of information. However, WE CANNOT ASSUME ANY RESPONSIBILITY FOR POSSIBLE ERROR



Important: See Safety Information in General Information Section (J300P-GI)

How To Use This Catalog

You must know several things about the application in order to find the correct end fitting part number:



Pos	Series	Spline Data	Hub Dia	* to End of Hub	End Fitting Part Number
CM55 (Continued)					
1	1610	1.998-38	2.750	7.562	EY 5-4-7601-1 <i>Flanged end yoke.</i>
1	1710	1.998-38	2.750	5.250	EY 6-4-7301
1	1710	1.998-38	2.750	5.250	EY 6-4-7301-1
CM59					
1	1610	1.998-38	2.750	4.688	CF 5-1-6271 <i>Can be used w/brake; Assembly includes eight 6-73-725 bolts</i>
1	SPL140	1.998-38	2.750	4.830	EY 140-4-111-1
1	SPL140	1.998-38	2.750	4.730	EY 140-4-891-1
1	SPL170	1.998-38	2.750	4.844	EY 170-4-541-1
1	SPL90	1.998-38	2.750	7.562	EY 90-4-111-1 <i>Can be used w/brake; Flanged end yoke.</i>

Pos	Series	Spline Data	Hub Dia	* to End of Hub	End Fitting Part Number
ESO65-7 (Continued)					
1	1610	1.998-38	2.750	7.562	EY 5-4-7601-1 <i>Flanged end yoke.</i>
1	1710	1.998-38	2.750	5.250	EY 6-4-7301
1	1710	1.998-38	2.750	5.250	EY 6-4-7301-1
ESO66-7					
1	1550	1.998-38	2.750	4.047	EY 4-4-4491-1
1	1550	1.998-38	2.750	4.156	EY 4-4-4611
1	1550	1.998-38	2.750	4.156	EY 4-4-4611-1
1	1550	1.998-38	2.750	4.156	EY 4-4-4611-2 <i>Attaching hardware by OEM</i>
1	1610	1.998-38	2.750	4.125	EY 5-4-6321
1	1610	1.998-38	2.750	4.000	EY 5-4-6321-1

1. The type of unit it is used on:

- Main or Auxiliary Transmission
- Single or Tandem Axle
- Split Shaft P.T.O.
- Transfer Case

2. The manufacturer and model:

- Example: Spicer ES60-5, Fuller RT-11608, Rockwell F-3200, etc.

3. Where the part is used on the original unit:

- Transmission output (position 1)
- Single Axle input (position 1) or output (positions 2, 3 or 4)
- Tandem Axle input to 1st axle (position 1), output of 1st Axle (position 2) or input to 2nd Axle (position 3)
- Split Shaft or Auxiliary Transmission (position 1) or output (position 2)

4. The type of part and series:

- Companion Flange - CF (typically "-1" center digit)
- End Yoke - EY (typically "-4" center digit)

5. Dimensions of the part:

- Spline O.D.
- Number of teeth
- Length thru hole
- Seal diameter

Once you have selected the part number based on the above criteria, make sure the dimensions of your part match the dimensions shown in the catalog for the part number you selected. If they do not match, contact the transmission or axle manufacturer. Some manufacturers have made spline and/or seal changes within a given model number and the model number shown in this catalog could include parts that have different dimensions. You must choose a part with the correct dimensions or **the part will not fit.**

Locating Model Designation Information

Axle Model Identification, Part Number and Serial Number are located on a tag at the axle centerline. This information will help to locate information in this book and to identify the correct parts for servicing.

For the latest product additions and program details, visit us on the web at www.spicerparts.com.

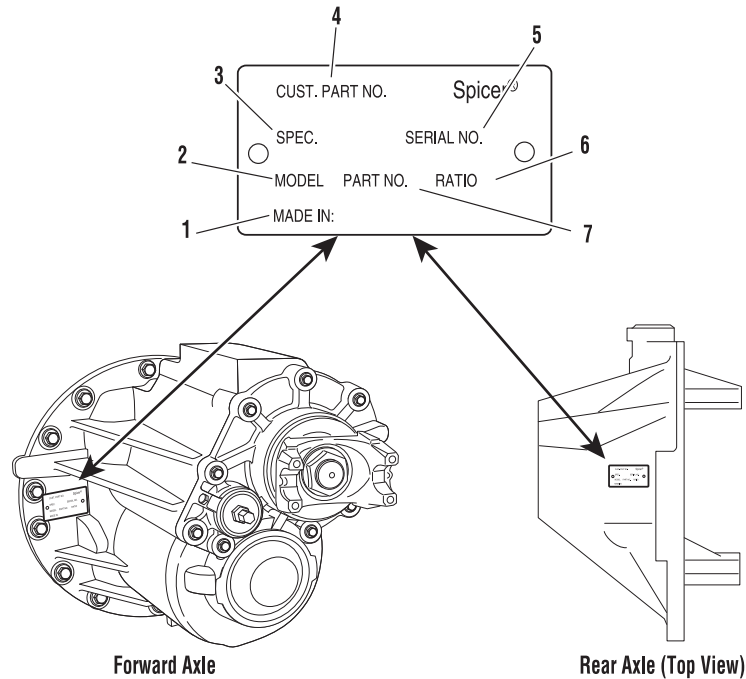

- 1 - Country or origin
- 2 - Axle model identification
- 3 - Specification number assigned to the axle built by Spicer. Identifies all component parts of the axle including special OEM requirements such as yokes or flanges.
- 4 - OEM part number assigned to the axle build
- 5 - Carrier assembly serial number assigned by the manufacturing plant
- 6 - Axle gear ratio
- 7 - Carrier assembly production or service part number

Model Information

Some Model call-outs on tags vary and for the purpose of this catalog, some model designations are abbreviated as shown in the examples below:

Tandem Axles: Spicer DS404 models are referred to as Model 404

Spicer D46-170 & R46-170 are referred to as Model D170 & R170

Spicer D40-155 & D40-156 are referred to as Models D155 & D156

Single Drive Axle - Nomenclature

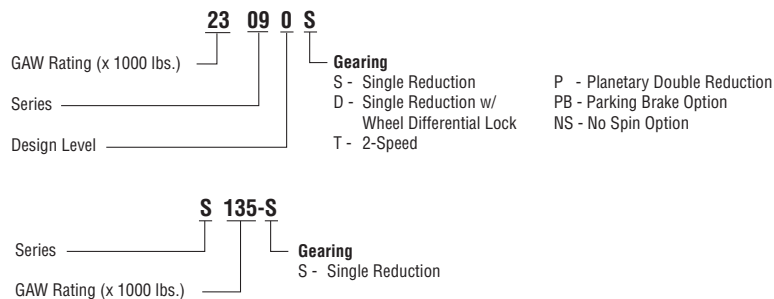

Spicer Axle Model Identification

Tandem Drive Axle - Nomenclature

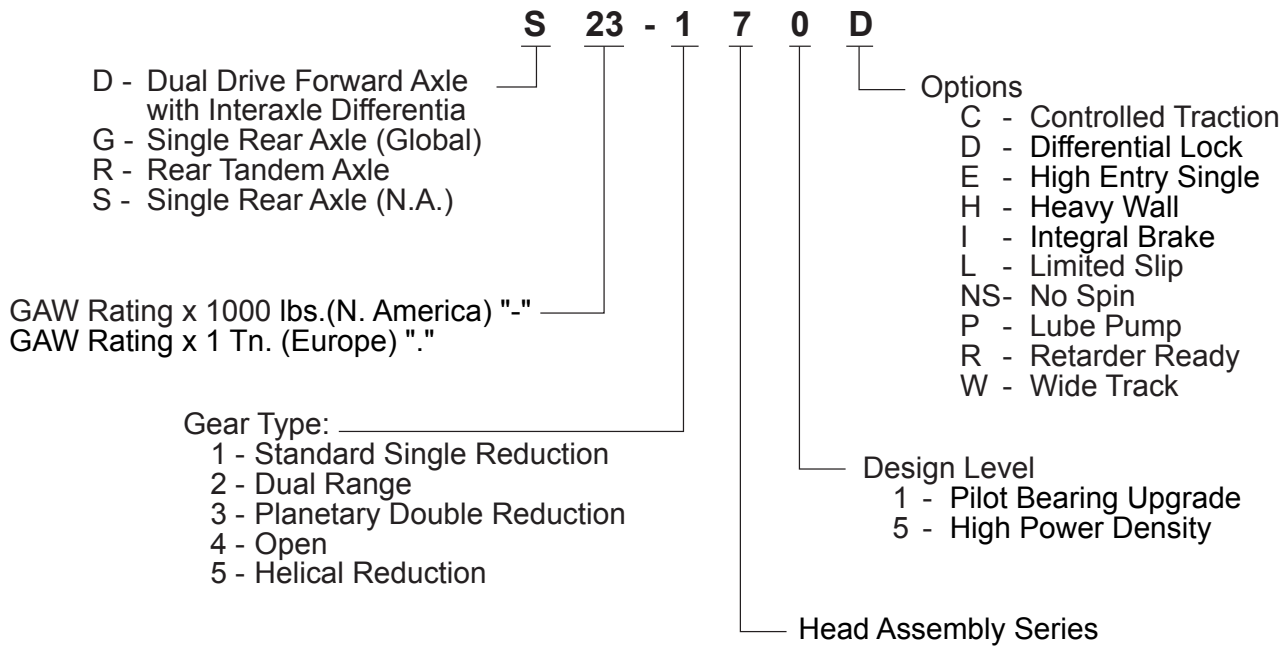
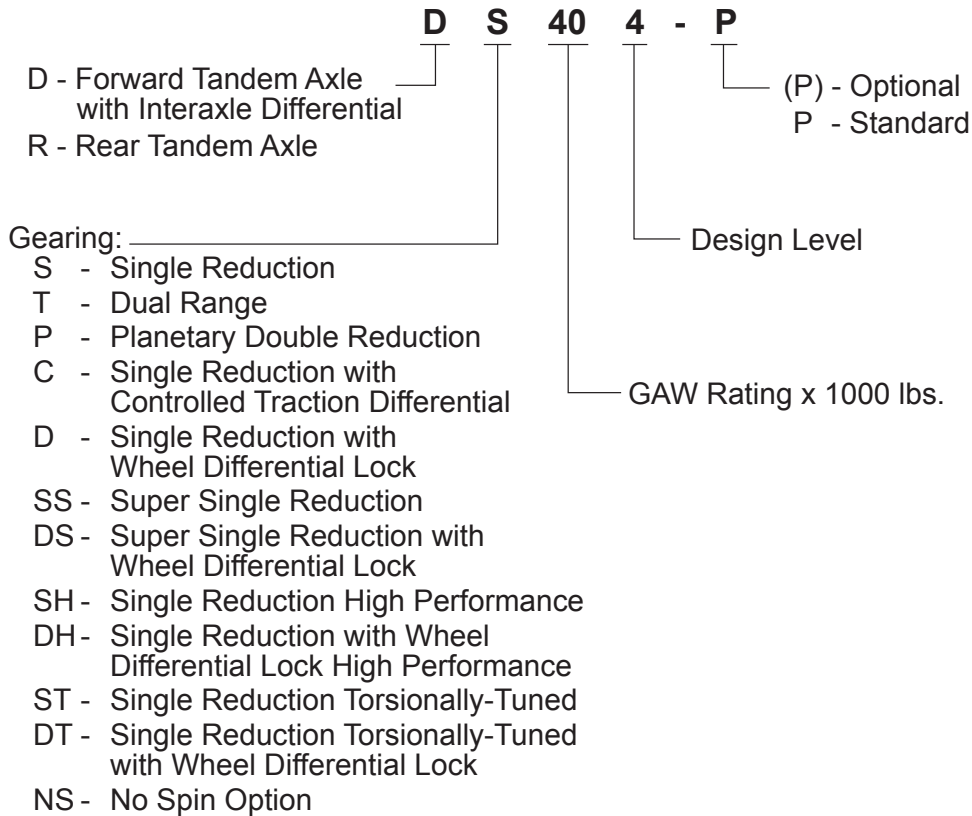

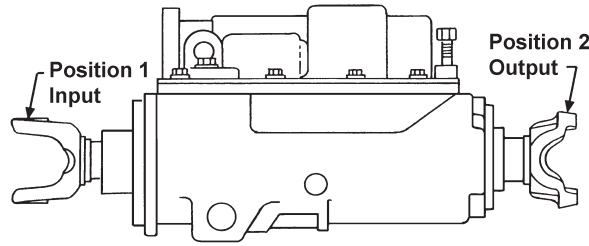

Pos	Series	Spline Data	Hub Dia	* to End of Hub	End Fitting Part Number
-----	--------	-------------	---------	-----------------	-------------------------

AT-1202

1	SPL140	2.750-10	3.750	6.570	EY 140-4-61-1
1	SPL140	2.750-10	3.750	6.570	EY 140-4-71-1X
1	SPL170	2.750-10	3.750	5.850	EY 170-4-491-1
1	SPL170	2.750-10	3.750	5.850	EY 170-4-501-1X
1	SPL250	2.750-10	3.750	6.300	EY 250-4-211-1
1	SPL250	2.750-10	3.750	6.300	EY 250-4-221-1X
1	1710	2.750-10	3.500	5.750	EY 6-4-5251X
1	1710	2.750-10	3.750	5.750	EY 6-4-6631
1	1710	2.750-10	3.750	5.750	EY 6-4-6631-1
1	1710	2.750-10	3.750	5.750	EY 6-4-6841-1X
1	1710	2.750-10	3.750	5.750	EY 6-4-6841X
1	1760	2.750-10	3.750	5.969	EY 6.3-4-661
1	1760	2.750-10	3.750	5.969	EY 6.3-4-661-1
1	1760	2.750-10	3.750	5.969	EY 6.3-4-721-1X
1	1760	2.750-10	3.750	5.969	EY 6.3-4-721X
1	1810	2.750-10	3.500	6.062	EY 6.5-4-1901
1	1810	2.750-10	3.500	6.062	EY 6.5-4-1901-1
1	1810	2.750-10	3.500	6.062	EY 6.5-4-2931X
1	1810	2.750-10	3.750	6.062	EY 6.5-4-3461
1	1810	2.750-10	3.750	6.062	EY 6.5-4-3461-1
1	1810	2.750-10	3.750	6.062	EY 6.5-4-3501-1X
1	1810	2.750-10	3.750	6.062	EY 6.5-4-3501X
2	1810	2.750-10	3.750	4.062	CF 6.5-1-2311
2	1810	2.750-10	3.750	4.062	CF 6.5-1-2361X
2	SPL140	2.750-10	3.750	6.570	EY 140-4-81-1
2	SPL140	2.750-10	3.750	6.570	EY 140-4-91-1X
2	SPL170	2.750-10	3.750	5.850	EY 170-4-511-1
2	SPL170	2.750-10	3.750	5.850	EY 170-4-521-1X
2	SPL250	2.750-10	3.750	6.297	EY 250-4-231-1
2	SPL250	2.750-10	3.750	6.297	EY 250-4-241-1X
2	SPL350	2.750-10	3.752	6.614	EY 350-4-131-1
2	SPL350	2.750-10	3.752	6.614	EY 350-4-141-1X
2	1710	2.750-10	3.750	5.750	EY 6-4-6821
2	1710	2.750-10	3.750	5.750	EY 6-4-6821-1
2	1710	2.750-10	3.750	5.750	EY 6-4-6931-1X
2	1710	2.750-10	3.750	5.750	EY 6-4-6931X
2	1760	2.750-10	3.750	5.969	EY 6.3-4-711
2	1760	2.750-10	3.750	5.969	EY 6.3-4-711-1
2	1760	2.750-10	3.750	5.969	EY 6.3-4-791-1X
2	1760	2.750-10	3.750	5.969	EY 6.3-4-791X
2	1810	2.750-10	3.750	6.062	EY 6.5-4-3491
2	1810	2.750-10	3.750	6.062	EY 6.5-4-3491-1
2	1810	2.750-10	3.750	6.062	EY 6.5-4-3561-1X
2	1810	2.750-10	3.750	6.062	EY 6.5-4-3561X

MRT-915, MRT-9509, MRT-9513

2	1710	2.500-10	3.750	3.625	CF 6-1-5541
2	1710	2.500-10	3.750	3.625	CF 6-1-5651X
2	1810	2.500-10	3.750	3.625	CF 6.5-1-2271
2	1810	2.500-10	3.750	3.625	CF 6.5-1-2351X

Pos	Series	Spline Data	Hub Dia	* to End of Hub	End Fitting Part Number
-----	--------	-------------	---------	-----------------	-------------------------

MRT-915, MRT-9509, MRT-9513 (Continued)

2	SPL170	2.500-10	3.750	5.750	EY 170-4-471-1■
2	SPL170	2.500-10	3.750	5.750	EY 170-4-481-1X■
2	SPL250	2.500-10	3.750	6.062	EY 250-4-191-1■
2	SPL250	2.500-10	3.750	6.062	EY 250-4-201-1X■
2	1710	2.500-10	3.750	5.625	EY 6-4-6611■
2	1710	2.500-10	3.750	5.625	EY 6-4-6611-1■
2	1760	2.500-10	3.750	6.000	EY 6.3-4-651■
2	1760	2.500-10	3.750	6.031	EY 6.3-4-651-1■
2	1810	2.500-10	3.750	5.875	EY 6.5-4-3551-1X■
2	1810	2.500-10	3.750	5.875	EY 6.5-4-3551X■

MRT-11609, MRT-11610, MRT-11613

2	1710	2.500-10	3.750	3.625	CF 6-1-5541
2	1710	2.500-10	3.750	3.625	CF 6-1-5651X
2	1810	2.500-10	3.750	3.625	CF 6.5-1-2271
2	1810	2.500-10	3.750	3.625	CF 6.5-1-2351X
2	SPL170	2.500-10	3.750	5.750	EY 170-4-471-1■
2	SPL170	2.500-10	3.750	5.750	EY 170-4-481-1X■
2	SPL250	2.500-10	3.750	6.062	EY 250-4-191-1■
2	SPL250	2.500-10	3.750	6.062	EY 250-4-201-1X■
2	1710	2.500-10	3.750	5.625	EY 6-4-6611■
2	1710	2.500-10	3.750	5.625	EY 6-4-6611-1■
2	1710	2.500-10	3.750	5.625	EY 6-4-6921-1X■
2	1710	2.500-10	3.750	5.625	EY 6-4-6921X■
2	1760	2.500-10	3.750	6.000	EY 6.3-4-651■
2	1760	2.500-10	3.750	6.031	EY 6.3-4-651-1■
2	1760	2.500-10	3.750	6.031	EY 6.3-4-781-1X■
2	1760	2.500-10	3.750	6.000	EY 6.3-4-781X■
2	1810	2.500-10	3.750	5.875	EY 6.5-4-3451■
2	1810	2.500-10	3.750	5.875	EY 6.5-4-3451-1■
2	1810	2.500-10	3.750	5.875	EY 6.5-4-3551-1X■
2	1810	2.500-10	3.750	5.875	EY 6.5-4-3551X■

MRT-11615

2	1710	2.500-10	3.750	3.625	CF 6-1-5541
2	1810	2.500-10	3.750	3.625	CF 6.5-1-2271
2	1710	2.500-10	3.750	5.625	EY 6-4-6611■
2	1710	2.500-10	3.750	5.625	EY 6-4-6611-1■
2	1710	2.500-10	3.750	5.625	EY 6-4-6921-1X■
2	1710	2.500-10	3.750	5.625	EY 6-4-6921X■
2	1760	2.500-10	3.750	6.000	EY 6.3-4-651■
2	1760	2.500-10	3.750	6.031	EY 6.3-4-651-1■
2	1760	2.500-10	3.750	6.031	EY 6.3-4-781-1X■
2	1760	2.500-10	3.750	6.000	EY 6.3-4-781X■
2	1810	2.500-10	3.750	5.875	EY 6.5-4-3451■
2	1810	2.500-10	3.750	5.875	EY 6.5-4-3451-1■
2	1810	2.500-10	3.750	5.875	EY 6.5-4-3551-1X■
2	1810	2.500-10	3.750	5.875	EY 6.5-4-3551X■

*C/L to End of Hub for EY (End Yoke); Flange Face to End of Hub for CF (Companion Flange)

■ Hub machined for speedometer gear



Pos	Series	Spline Data	Hub Dia	* to End of Hub	End Fitting Part Number
MT-905					
2	1610	2.250-10	3.500	3.625	CF 5-1-6331
2	1710	2.500-10	3.750	3.625	CF 6-1-5541
2	1810	2.250-10	3.500	3.688	CF 6.5-1-151
2	1810	2.500-10	3.750	3.625	CF 6.5-1-2271
2	SPL170	2.250-10	3.500	5.750	EY 170-4-451-1
2	SPL170	2.250-10	3.500	5.750	EY 170-4-461-1X
2	SPL90	2.250-10	3.500	5.219	EY 90-4-151-1X
2	SPL90	2.250-10	3.500	5.219	EY 90-4-401-1
2	1550	2.250-10	3.500	5.125	EY 4-4-3501-1
2	1610	2.250-10	3.500	5.750	EY 5-4-4961
2	1610	2.250-10	3.500	5.750	EY 5-4-4961-1
2	1710	2.500-10	3.750	5.625	EY 6-4-6611■
2	1710	2.500-10	3.750	5.625	EY 6-4-6611-1■
2	1710	2.250-10	3.500	5.250	EY 6-4-6861
2	1710	2.250-10	3.500	5.250	EY 6-4-6861-1
2	1710	2.250-10	3.500	5.250	EY 6-4-6901-1X
2	1760	2.500-10	3.750	6.000	EY 6.3-4-651■
2	1760	2.500-10	3.750	6.031	EY 6.3-4-651-1■
2	1810	2.250-10	3.500	5.844	EY 6.5-4-2021
2	1810	2.500-10	3.750	5.875	EY 6.5-4-3551-1X■
2	1810	2.500-10	3.750	5.875	EY 6.5-4-3551X■

MT-11605					
1	SPL170	2.250-10	3.500	5.750	CF 170-4-451-1
1	SPL170	2.250-10	3.500	5.750	CF 170-4-461-1X
2	1610/1550	2.250-10	3.500	3.625	CF 5-1-6331
2	1710	2.500-10	3.750	3.625	CF 6-1-5541
2	1710	2.500-10	3.750	3.625	CF 6-1-5651X
2	1810	2.250-10	3.500	3.688	CF 6.5-1-151
2	1810	2.500-10	3.750	3.625	CF 6.5-1-2271
2	1810	2.500-10	3.750	3.625	CF 6.5-1-2351X
2	SPL170	2.500-10	3.750	5.750	EY 170-4-471-1■
2	SPL170	2.500-10	3.750	5.750	EY 170-4-481-1X■
2	SPL250	2.500-10	3.750	6.062	EY 250-4-191-1■
2	SPL250	2.500-10	3.750	6.062	EY 250-4-201-1X■
2	SPL90	2.250-10	3.500	5.219	EY 90-4-151-1X
2	SPL90	2.250-10	3.500	5.219	EY 90-4-401-1
2	1550	2.250-10	3.500	5.125	EY 4-4-3501-1
2	1610	2.250-10	3.500	5.750	EY 5-4-4961
2	1610	2.250-10	3.500	5.750	EY 5-4-4961-1
2	1610	2.250-10	3.750	5.750	EY 5-4-7381-1
2	1710	2.500-10	3.750	5.625	EY 6-4-6611■
2	1710	2.500-10	3.750	5.625	EY 6-4-6611-1■
2	1710	2.250-10	3.500	5.250	EY 6-4-6861
2	1710	2.250-10	3.500	5.250	EY 6-4-6861-1
2	1710	2.250-10	3.500	5.250	EY 6-4-6901-1X
2	1710	2.250-10	3.750	5.250	EY 6-4-7371-1
2	1760	2.250-10	3.750	5.625	EY 6.3-4-1091-1
2	1760	2.500-10	3.750	6.000	EY 6.3-4-651■
2	1760	2.500-10	3.750	6.031	EY 6.3-4-651-1■
2	1760	2.250-10	3.500	5.656	EY 6.3-4-701-1
2	1760	2.250-10	3.500	5.656	EY 6.3-4-761-1X
2	1760	2.500-10	3.750	6.031	EY 6.3-4-781-1X■
2	1760	2.500-10	3.750	6.000	EY 6.3-4-781X■
2	1810	2.250-10	3.500	5.844	EY 6.5-4-2021
2	1810	2.500-10	3.750	5.875	EY 6.5-4-3451■
2	1810	2.500-10	3.750	5.875	EY 6.5-4-3451-1■
2	1810	2.500-10	3.750	5.875	EY 6.5-4-3551-1X■
2	1810	2.500-10	3.750	5.875	EY 6.5-4-3551X■

Pos	Series	Spline Data	Hub Dia	* to End of Hub	End Fitting Part Number
T-904					
1	1610	2.250-10	3.500	3.625	CF 5-1-6331
1	1710	2.250-10	3.500	3.688	CF 6-1-951
1	1810	2.250-10	3.500	3.688	CF 6.5-1-151
1	1550	2.250-10	3.500	5.125	EY 4-4-3501-1
1	1610	2.250-10	3.500	5.750	EY 5-4-4961
1	1610	2.250-10	3.500	5.750	EY 5-4-4961-1
1	1710	2.250-10	3.500	5.250	EY 6-4-2141
1	1710	2.250-10	3.500	5.250	EY 6-4-6861
1	1710	2.250-10	3.500	5.250	EY 6-4-6861-1
1	1710	2.250-10	3.500	5.250	EY 6-4-6901-1X
1	1710	2.250-10	3.500	5.250	EY 6-4-6901X
1	1760	2.250-10	3.500	5.656	EY 6.3-4-701-1
1	1810	2.250-10	3.500	5.844	EY 6.5-4-2021
2	1610	2.250-10	3.500	3.625	CF 5-1-6331
2	1710	2.250-10	3.500	3.688	CF 6-1-951
2	1810	2.250-10	3.500	3.688	CF 6.5-1-151
2	1610	2.250-10	3.500	5.750	EY 5-4-4961
2	1610	2.250-10	3.500	5.750	EY 5-4-4961-1
2	1710	2.250-10	3.500	5.250	EY 6-4-2141
2	1710	2.250-10	3.500	5.250	EY 6-4-6861
2	1710	2.250-10	3.500	5.250	EY 6-4-6861-1
2	1710	2.250-10	3.500	5.250	EY 6-4-6901-1X
2	1710	2.250-10	3.500	5.250	EY 6-4-6901X
2	1760	2.250-10	3.500	5.656	EY 6.3-4-701-1
2	1810	2.250-10	3.500	5.844	EY 6.5-4-2021

2 SP. 62					
2	1610	2.000-10	3.250	3.625	CF 5-1-931
2	1710	2.000-10	3.250	5.625	EY 6-4-2001

2 SP. 92					
1	1610	2.250-10	3.500	3.625	CF 5-1-6331
1	1810	2.250-10	3.500	3.688	CF 6.5-1-151
1	SPL170	2.250-10	3.500	5.750	EY 170-4-451-1
1	SPL170	2.250-10	3.500	5.750	EY 170-4-461-1X
1	SPL90	2.250-10	3.500	5.219	EY 90-4-151-1X
1	SPL90	2.250-10	3.500	5.219	EY 90-4-401-1
1	1550	2.250-10	3.500	5.125	EY 4-4-3501-1
1	1610	2.250-10	3.500	5.750	EY 5-4-4961
1	1610	2.250-10	3.500	5.750	EY 5-4-4961-1
1	1710	2.250-10	3.500	5.250	EY 6-4-6861
1	1710	2.250-10	3.500	5.250	EY 6-4-6861-1
1	1710	2.250-10	3.500	5.250	EY 6-4-6901-1X
1	1810	2.250-10	3.500	5.844	EY 6.5-4-2021

3 SP. 62					
1	1610	2.000-10	3.250	3.625	CF 5-1-931
1	1710	2.000-10	3.250	5.625	EY 6-4-2001

3 SP. 65					
1	1610	2.250-10	3.500	3.625	CF 5-1-6331
1	1610	2.000-10	3.250	3.625	CF 5-1-931
1	1810	2.250-10	3.500	3.688	CF 6.5-1-151
1	SPL170	2.250-10	3.500	5.750	EY 170-4-451-1
1	SPL170	2.250-10	3.500	5.750	EY 170-4-461-1X
1	SPL90	2.250-10	3.500	5.219	EY 90-4-151-1X
1	SPL90	2.250-10	3.500	5.219	EY 90-4-401-1
1	1550	2.250-10	3.500	5.125	EY 4-4-3501-1
1	1610	2.250-10	3.500	5.750	EY 5-4-4961
1	1610	2.250-10	3.500	5.750	EY 5-4-4961-1

Continued on next page

*C/L to End of Hub for EY (End Yoke); Flange Face to End of Hub for CF (Companion Flange)

■ Hub machined for speedometer gear



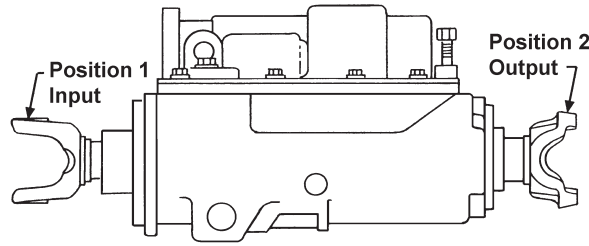

Pos	Series	Spline Data	Hub Dia	* to End of Hub	End Fitting Part Number
3 SP. 65 (Continued)					
1	1710	2.000-10	3.250	5.625	EY 6-4-2001
1	1710	2.250-10	3.500	5.250	EY 6-4-6861
1	1710	2.250-10	3.500	5.250	EY 6-4-6861-1
1	1710	2.250-10	3.500	5.250	EY 6-4-6901-1X
1	1810	2.250-10	3.500	5.844	EY 6.5-4-2021

3 SP. 92					
1	1610	2.250-10	3.500	3.625	CF 5-1-6331
1	1810	2.250-10	3.500	3.688	CF 6.5-1-151
1	SPL170	2.250-10	3.500	5.750	EY 170-4-451-1
1	SPL170	2.250-10	3.500	5.750	EY 170-4-461-1X
1	SPL90	2.250-10	3.500	5.219	EY 90-4-151-1X
1	SPL90	2.250-10	3.500	5.219	EY 90-4-401-1
1	1610	2.250-10	3.500	5.750	EY 5-4-4961
1	1610	2.250-10	3.500	5.750	EY 5-4-4961-1
1	1710	2.250-10	3.500	5.250	EY 6-4-6861
1	1710	2.250-10	3.500	5.250	EY 6-4-6861-1
1	1710	2.250-10	3.500	5.250	EY 6-4-6901-1X
1	1810	2.250-10	3.500	5.844	EY 6.5-4-2021

5 SP. 1120, 5 SP. 1220					
2	1610	2.250-10	3.500	3.625	CF 5-1-6331
2	1810	2.250-10	3.500	3.688	CF 6.5-1-151
2	SPL170	2.250-10	3.500	5.750	EY 170-4-451-1
2	SPL170	2.250-10	3.500	5.750	EY 170-4-461-1X
2	SPL90	2.250-10	3.500	5.219	EY 90-4-151-1X
2	SPL90	2.250-10	3.500	5.219	EY 90-4-401-1
2	1550	2.250-10	3.500	5.125	EY 4-4-3501-1
2	1610	2.250-10	3.500	5.750	EY 5-4-4961
2	1610	2.250-10	3.500	5.750	EY 5-4-4961-1
2	1710	2.250-10	3.500	5.250	EY 6-4-6861
2	1710	2.250-10	3.500	5.250	EY 6-4-6861-1
2	1710	2.250-10	3.500	5.250	EY 6-4-6901-1X
2	1810	2.250-10	3.500	5.844	EY 6.5-4-2021

5 SP. 65, 5 SP. 74, 5 SP. 75, 5 SP. 650, 5 SP. 740					
1	1610	2.000-10	3.250	3.625	CF 5-1-931
1	1710	2.000-10	3.250	5.625	EY 6-4-2001

10 SP. 65					
2	1610	2.250-10	3.500	3.625	CF 5-1-6331
2	1810	2.250-10	3.500	3.688	CF 6.5-1-151
2	SPL170	2.250-10	3.500	5.750	EY 170-4-451-1
2	SPL170	2.250-10	3.500	5.750	EY 170-4-461-1X
2	SPL90	2.250-10	3.500	5.219	EY 90-4-151-1X
2	SPL90	2.250-10	3.500	5.219	EY 90-4-401-1
2	1550	2.250-10	3.500	5.125	EY 4-4-3501-1
2	1610	2.250-10	3.500	5.750	EY 5-4-4961
2	1610	2.250-10	3.500	5.750	EY 5-4-4961-1
2	1710	2.250-10	3.500	5.250	EY 6-4-6861
2	1710	2.250-10	3.500	5.250	EY 6-4-6861-1
2	1710	2.250-10	3.500	5.250	EY 6-4-6901-1X
2	1810	2.250-10	3.500	5.844	EY 6.5-4-2021

Pos	Series	Spline Data	Hub Dia	* to End of Hub	End Fitting Part Number
10 SP. 650					
2	1610	2.250-10	3.500	3.625	CF 5-1-6331
2	1810	2.250-10	3.500	3.688	CF 6.5-1-151
2	SPL170	2.250-10	3.500	5.750	EY 170-4-451-1
2	SPL170	2.250-10	3.500	5.750	EY 170-4-461-1X
2	SPL90	2.250-10	3.500	5.219	EY 90-4-151-1X
2	SPL90	2.250-10	3.500	5.219	EY 90-4-401-1
2	1550	2.250-10	3.500	5.125	EY 4-4-3501-1
2	1610	2.250-10	3.500	5.750	EY 5-4-4961-1
2	1710	2.250-10	3.500	5.250	EY 6-4-6861
2	1710	2.250-10	3.500	5.250	EY 6-4-6901-1X
2	1810	2.250-10	3.500	5.844	EY 6.5-4-2021

10 SP. 1120, 15 SP. 1120					
2	1610	2.250-10	3.500	3.625	CF 5-1-6331
2	1810	2.250-10	3.500	3.688	CF 6.5-1-151
2	SPL170	2.250-10	3.500	5.750	EY 170-4-451-1
2	SPL170	2.250-10	3.500	5.750	EY 170-4-461-1X
2	SPL90	2.250-10	3.500	5.219	EY 90-4-151-1X
2	SPL90	2.250-10	3.500	5.219	EY 90-4-401-1
2	1550	2.250-10	3.500	5.125	EY 4-4-3501-1
2	1610	2.250-10	3.500	5.750	EY 5-4-4961
2	1610	2.250-10	3.500	5.750	EY 5-4-4961-1
2	1710	2.250-10	3.500	5.250	EY 6-4-6861
2	1710	2.250-10	3.500	5.250	EY 6-4-6861-1
2	1710	2.250-10	3.500	5.250	EY 6-4-6901-1X
2	1810	2.250-10	3.500	5.844	EY 6.5-4-2021

2-A-53, 2-A-62					
2	1610	2.000-10	3.250	3.625	CF 5-1-931
2	1710	2.000-10	3.250	5.625	EY 6-4-2001

2-A-92					
1	1610	2.250-10	3.500	3.625	CF 5-1-6331
1	1810	2.250-10	3.500	3.688	CF 6.5-1-151
1	SPL170	2.250-10	3.500	5.750	EY 170-4-451-1
1	SPL170	2.250-10	3.500	5.750	EY 170-4-461-1X
1	SPL90	2.250-10	3.500	5.219	EY 90-4-151-1X
1	SPL90	2.250-10	3.500	5.219	EY 90-4-401-1
1	1550	2.250-10	3.500	5.125	EY 4-4-3501-1
1	1610	2.250-10	3.500	5.750	EY 5-4-4961
1	1610	2.250-10	3.500	5.750	EY 5-4-4961-1
1	1710	2.250-10	3.500	5.250	EY 6-4-6861
1	1710	2.250-10	3.500	5.250	EY 6-4-6861-1
1	1710	2.250-10	3.500	5.250	EY 6-4-6901-1X
1	1810	2.250-10	3.500	5.844	EY 6.5-4-2021
2	1610	2.250-10	3.500	3.625	CF 5-1-6331
2	1810	2.250-10	3.500	3.688	CF 6.5-1-151
2	SPL170	2.250-10	3.500	5.750	EY 170-4-451-1
2	SPL170	2.250-10	3.500	5.750	EY 170-4-461-1X
2	SPL90	2.250-10	3.500	5.219	EY 90-4-151-1X
2	SPL90	2.250-10	3.500	5.219	EY 90-4-401-1

*C/L to End of Hub for EY (End Yoke); Flange Face to End of Hub for CF (Companion Flange)

■ Hub machined for speedometer gear



Pos	Series	Spline Data	Hub Dia	* to End of Hub	End Fitting Part Number
2-A-92 (Continued)					
2	1550	2.250-10	3.500	5.125	EY 4-4-3501-1
2	1610	2.250-10	3.500	5.750	EY 5-4-4961
2	1610	2.250-10	3.500	5.750	EY 5-4-4961-1
2	1710	2.250-10	3.500	5.250	EY 6-4-6861
2	1710	2.250-10	3.500	5.250	EY 6-4-6861-1
2	1710	2.250-10	3.500	5.250	EY 6-4-6901-1X
2	1810	2.250-10	3.500	5.844	EY 6.5-4-2021

2-B-53, 2-B-62					
2	1610	2.000-10	3.250	3.625	CF 5-1-931
2	1710	2.000-10	3.250	5.625	EY 6-4-2001

2-B-92					
1	1610	2.250-10	3.500	3.625	CF 5-1-6331
1	1810	2.250-10	3.500	3.688	CF 6.5-1-151
1	SPL170	2.250-10	3.500	5.750	EY 170-4-451-1
1	SPL170	2.250-10	3.500	5.750	EY 170-4-461-1X
1	SPL90	2.250-10	3.500	5.219	EY 90-4-151-1X
1	SPL90	2.250-10	3.500	5.219	EY 90-4-401-1
1	1550	2.250-10	3.500	5.125	EY 4-4-3501-1
1	1610	2.250-10	3.500	5.750	EY 5-4-4961
1	1610	2.250-10	3.500	5.750	EY 5-4-4961-1
1	1710	2.250-10	3.500	5.250	EY 6-4-6861
1	1710	2.250-10	3.500	5.250	EY 6-4-6861-1
1	1710	2.250-10	3.500	5.250	EY 6-4-6901-1X
1	1810	2.250-10	3.500	5.844	EY 6.5-4-2021
2	1610	2.250-10	3.500	3.625	CF 5-1-6331
2	1810	2.250-10	3.500	3.688	CF 6.5-1-151
2	SPL170	2.250-10	3.500	5.750	EY 170-4-451-1
2	SPL170	2.250-10	3.500	5.750	EY 170-4-461-1X
2	SPL90	2.250-10	3.500	5.219	EY 90-4-151-1X
2	SPL90	2.250-10	3.500	5.219	EY 90-4-401-1
2	1550	2.250-10	3.500	5.125	EY 4-4-3501-1
2	1610	2.250-10	3.500	5.750	EY 5-4-4961
2	1610	2.250-10	3.500	5.750	EY 5-4-4961-1
2	1710	2.250-10	3.500	5.250	EY 6-4-6861
2	1710	2.250-10	3.500	5.250	EY 6-4-6861-1
2	1710	2.250-10	3.500	5.250	EY 6-4-6901-1X
2	1810	2.250-10	3.500	5.844	EY 6.5-4-2021

3-A-65					
1	1610	2.000-10	3.250	3.625	CF 5-1-931
1	1710	2.000-10	3.250	5.625	EY 6-4-2001
2	1610	2.250-10	3.500	3.625	CF 5-1-6331
2	1710	2.250-10	3.500	3.688	CF 6-1-951
2	1810	2.250-10	3.500	3.688	CF 6.5-1-151
2	1550	2.250-10	3.500	5.125	EY 4-4-3501-1
2	1610	2.250-10	3.500	5.750	EY 5-4-4961
2	1610	2.250-10	3.500	5.750	EY 5-4-4961-1
2	1710	2.250-10	3.500	5.250	EY 6-4-2141
2	1710	2.250-10	3.500	5.250	EY 6-4-6861
2	1710	2.250-10	3.500	5.250	EY 6-4-6861-1
2	1710	2.250-10	3.500	5.250	EY 6-4-6901-1X
2	1710	2.250-10	3.500	5.250	EY 6-4-6901X
2	1760	2.250-10	3.500	5.656	EY 6.3-4-701-1
2	1810	2.250-10	3.500	5.844	EY 6.5-4-2021

3-A-92					
1	1610	2.250-10	3.500	3.625	CF 5-1-6331
1	1710	2.250-10	3.500	3.688	CF 6-1-951
1	1810	2.250-10	3.500	3.688	CF 6.5-1-151

Pos	Series	Spline Data	Hub Dia	* to End of Hub	End Fitting Part Number
3-A-92 (Continued)					
1	1550	2.250-10	3.500	5.125	EY 4-4-3501-1
1	1610	2.250-10	3.500	5.750	EY 5-4-4961
1	1610	2.250-10	3.500	5.750	EY 5-4-4961-1
1	1710	2.250-10	3.500	5.250	EY 6-4-2141
1	1710	2.250-10	3.500	5.250	EY 6-4-6861
1	1710	2.250-10	3.500	5.250	EY 6-4-6861-1
1	1710	2.250-10	3.500	5.250	EY 6-4-6901-1X
1	1710	2.250-10	3.500	5.250	EY 6-4-6901X
1	1760	2.250-10	3.500	5.656	EY 6.3-4-701-1
1	1810	2.250-10	3.500	5.844	EY 6.5-4-2021

1	1760	2.250-10	3.500	5.656	EY 6.3-4-701-1
1	1810	2.250-10	3.500	5.844	EY 6.5-4-2021
2	1610	2.250-10	3.500	3.625	CF 5-1-6331
2	1710	2.250-10	3.500	3.688	CF 6-1-951
2	1810	2.250-10	3.500	3.688	CF 6.5-1-151
2	1550	2.250-10	3.500	5.125	EY 4-4-3501-1
2	1610	2.250-10	3.500	5.750	EY 5-4-4961
2	1610	2.250-10	3.500	5.750	EY 5-4-4961-1
2	1710	2.250-10	3.500	5.250	EY 6-4-2141
2	1710	2.250-10	3.500	5.250	EY 6-4-6861
2	1710	2.250-10	3.500	5.250	EY 6-4-6861-1
2	1710	2.250-10	3.500	5.250	EY 6-4-6901-1X
2	1710	2.250-10	3.500	5.250	EY 6-4-6901X
2	1760	2.250-10	3.500	5.656	EY 6.3-4-701-1
2	1810	2.250-10	3.500	5.844	EY 6.5-4-2021

3-B-65					
1	1610	2.000-10	3.250	3.625	CF 5-1-931
1	1710	2.000-10	3.250	5.625	EY 6-4-2001
2	1610	2.250-10	3.500	3.625	CF 5-1-6331
2	1710	2.250-10	3.500	3.688	CF 6-1-951
2	1810	2.250-10	3.500	3.688	CF 6.5-1-151
2	1550	2.250-10	3.500	5.125	EY 4-4-3501-1
2	1610	2.250-10	3.500	5.750	EY 5-4-4961
2	1610	2.250-10	3.500	5.750	EY 5-4-4961-1
2	1710	2.250-10	3.500	5.250	EY 6-4-2141
2	1710	2.250-10	3.500	5.250	EY 6-4-6861
2	1710	2.250-10	3.500	5.250	EY 6-4-6861-1
2	1710	2.250-10	3.500	5.250	EY 6-4-6901-1X
2	1710	2.250-10	3.500	5.250	EY 6-4-6901X
2	1760	2.250-10	3.500	5.656	EY 6.3-4-701-1
2	1810	2.250-10	3.500	5.844	EY 6.5-4-2021

3-B-92					
1	1610	2.250-10	3.500	3.625	CF 5-1-6331
1	1710	2.250-10	3.500	3.688	CF 6-1-951
1	1810	2.250-10	3.500	3.688	CF 6.5-1-151
1	1550	2.250-10	3.500	5.125	EY 4-4-3501-1
1	1610	2.250-10	3.500	5.750	EY 5-4-4961
1	1610	2.250-10	3.500	5.750	EY 5-4-4961-1
1	1710	2.250-10	3.500	5.250	EY 6-4-2141
1	1710	2.250-10	3.500	5.250	EY 6-4-6861
1	1710	2.250-10	3.500	5.250	EY 6-4-6861-1
1	1710	2.250-10	3.500	5.250	EY 6-4-6901-1X
1	1710	2.250-10	3.500	5.250	EY 6-4-6901X
1	1760	2.250-10	3.500	5.656	EY 6.3-4-701-1
1	1810	2.250-10	3.500	5.844	EY 6.5-4-2021
2	1610	2.250-10	3.500	3.625	CF 5-1-6331
2	1710	2.250-10	3.500	3.688	CF 6-1-951
2	1810	2.250-10	3.500	3.688	CF 6.5-1-151

Continued on next page

*C/L to End of Hub for EY (End Yoke); Flange Face to End of Hub for CF (Companion Flange)

■ Hub machined for speedometer gear



Important: See Safety Information in General Information Section (J300P-GI)

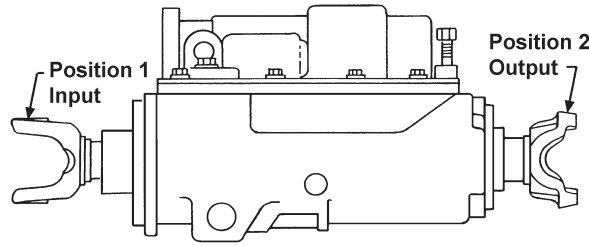

Pos	Series	Spline Data	Hub Dia	* to End of Hub	End Fitting Part Number
-----	--------	-------------	---------	-----------------	-------------------------

3-B-92 (Continued)

2	1550	2.250-10	3.500	5.125	EY 4-4-3501-1
2	1610	2.250-10	3.500	5.750	EY 5-4-4961
2	1610	2.250-10	3.500	5.750	EY 5-4-4961-1
2	1710	2.250-10	3.500	5.250	EY 6-4-2141
2	1710	2.250-10	3.500	5.250	EY 6-4-6861
2	1710	2.250-10	3.500	5.250	EY 6-4-6861-1
2	1710	2.250-10	3.500	5.250	EY 6-4-6901-1X
2	1710	2.250-10	3.500	5.250	EY 6-4-6901X
2	1760	2.250-10	3.500	5.656	EY 6.3-4-701-1
2	1810	2.250-10	3.500	5.844	EY 6.5-4-2021

3-C-65

1	1610	2.000-10	3.250	3.625	CF 5-1-931
1	1710	2.000-10	3.250	5.625	EY 6-4-2001
2	1610	2.250-10	3.500	3.625	CF 5-1-6331
2	1710	2.250-10	3.500	3.688	CF 6-1-951
2	1810	2.250-10	3.500	3.688	CF 6.5-1-151
2	1550	2.250-10	3.500	5.125	EY 4-4-3501-1
2	1610	2.250-10	3.500	5.750	EY 5-4-4961
2	1610	2.250-10	3.500	5.750	EY 5-4-4961-1
2	1710	2.250-10	3.500	5.250	EY 6-4-2141
2	1710	2.250-10	3.500	5.250	EY 6-4-6861
2	1710	2.250-10	3.500	5.250	EY 6-4-6861-1
2	1710	2.250-10	3.500	5.250	EY 6-4-6901-1X
2	1710	2.250-10	3.500	5.250	EY 6-4-6901X
2	1760	2.250-10	3.500	5.656	EY 6.3-4-701-1
2	1810	2.250-10	3.500	5.844	EY 6.5-4-2021

3-C-92

1	1610	2.250-10	3.500	3.625	CF 5-1-6331
1	1710	2.250-10	3.500	3.688	CF 6-1-951
1	1810	2.250-10	3.500	3.688	CF 6.5-1-151
1	1550	2.250-10	3.500	5.125	EY 4-4-3501-1
1	1610	2.250-10	3.500	5.750	EY 5-4-4961
1	1610	2.250-10	3.500	5.750	EY 5-4-4961-1
1	1710	2.250-10	3.500	5.250	EY 6-4-2141
1	1710	2.250-10	3.500	5.250	EY 6-4-6861
1	1710	2.250-10	3.500	5.250	EY 6-4-6861-1
1	1710	2.250-10	3.500	5.250	EY 6-4-6901-1X
1	1710	2.250-10	3.500	5.250	EY 6-4-6901X
1	1760	2.250-10	3.500	5.656	EY 6.3-4-701-1
1	1810	2.250-10	3.500	5.844	EY 6.5-4-2021
2	1610	2.250-10	3.500	3.625	CF 5-1-6331
2	1710	2.250-10	3.500	3.688	CF 6-1-951
2	1810	2.250-10	3.500	3.688	CF 6.5-1-151
2	1550	2.250-10	3.500	5.125	EY 4-4-3501-1
2	1610	2.250-10	3.500	5.750	EY 5-4-4961
2	1610	2.250-10	3.500	5.750	EY 5-4-4961-1
2	1710	2.250-10	3.500	5.250	EY 6-4-2141
2	1710	2.250-10	3.500	5.250	EY 6-4-6861
2	1710	2.250-10	3.500	5.250	EY 6-4-6861-1

Pos	Series	Spline Data	Hub Dia	* to End of Hub	End Fitting Part Number
-----	--------	-------------	---------	-----------------	-------------------------

3-C-92 (Continued)

2	1710	2.250-10	3.500	5.250	EY 6-4-6901-1X
2	1710	2.250-10	3.500	5.250	EY 6-4-6901X
2	1760	2.250-10	3.500	5.656	EY 6.3-4-701-1
2	1810	2.250-10	3.500	5.844	EY 6.5-4-2021

3-D-65

1	1610	2.000-10	3.250	3.625	CF 5-1-931
1	1710	2.000-10	3.250	5.625	EY 6-4-2001
2	1610	2.250-10	3.500	3.625	CF 5-1-6331
2	1710	2.250-10	3.500	3.688	CF 6-1-951
2	1810	2.250-10	3.500	3.688	CF 6.5-1-151
2	1550	2.250-10	3.500	5.125	EY 4-4-3501-1
2	1610	2.250-10	3.500	5.750	EY 5-4-4961
2	1610	2.250-10	3.500	5.750	EY 5-4-4961-1
2	1710	2.250-10	3.500	5.250	EY 6-4-2141
2	1710	2.250-10	3.500	5.250	EY 6-4-6861
2	1710	2.250-10	3.500	5.250	EY 6-4-6861-1
2	1710	2.250-10	3.500	5.250	EY 6-4-6901-1X
2	1710	2.250-10	3.500	5.250	EY 6-4-6901X
2	1760	2.250-10	3.500	5.656	EY 6.3-4-701-1
2	1810	2.250-10	3.500	5.844	EY 6.5-4-2021

3-D-92

1	1610	2.250-10	3.500	3.625	CF 5-1-6331
1	1710	2.250-10	3.500	3.688	CF 6-1-951
1	1810	2.250-10	3.500	3.688	CF 6.5-1-151
1	1550	2.250-10	3.500	5.125	EY 4-4-3501-1
1	1610	2.250-10	3.500	5.750	EY 5-4-4961
1	1610	2.250-10	3.500	5.750	EY 5-4-4961-1
1	1710	2.250-10	3.500	5.250	EY 6-4-2141
1	1710	2.250-10	3.500	5.250	EY 6-4-6861
1	1710	2.250-10	3.500	5.250	EY 6-4-6861-1
1	1710	2.250-10	3.500	5.250	EY 6-4-6901-1X
1	1710	2.250-10	3.500	5.250	EY 6-4-6901X
1	1760	2.250-10	3.500	5.656	EY 6.3-4-701-1
1	1810	2.250-10	3.500	5.844	EY 6.5-4-2021
2	1610	2.250-10	3.500	3.625	CF 5-1-6331
2	1710	2.250-10	3.500	3.688	CF 6-1-951
2	1810	2.250-10	3.500	3.688	CF 6.5-1-151
2	1550	2.250-10	3.500	5.125	EY 4-4-3501-1
2	1610	2.250-10	3.500	5.750	EY 5-4-4961
2	1610	2.250-10	3.500	5.750	EY 5-4-4961-1
2	1710	2.250-10	3.500	5.250	EY 6-4-2141
2	1710	2.250-10	3.500	5.250	EY 6-4-6861
2	1710	2.250-10	3.500	5.250	EY 6-4-6861-1
2	1710	2.250-10	3.500	5.250	EY 6-4-6901-1X
2	1710	2.250-10	3.500	5.250	EY 6-4-6901X
2	1760	2.250-10	3.500	5.656	EY 6.3-4-701-1
2	1810	2.250-10	3.500	5.844	EY 6.5-4-2021

*C/L to End of Hub for EY (End Yoke); Flange Face to End of Hub for CF (Companion Flange)

■ Hub machined for speedometer gear



Pos	Series	Spline Data	Hub Dia	* to End of Hub	End Fitting Part Number
3-E-65					
1	1610	2.000-10	3.250	3.625	CF 5-1-931
1	1710	2.000-10	3.250	5.625	EY 6-4-2001
2	1610	2.250-10	3.500	3.625	CF 5-1-6331
2	1710	2.250-10	3.500	3.688	CF 6-1-951
2	1810	2.250-10	3.500	3.688	CF 6.5-1-151
2	1550	2.250-10	3.500	5.125	EY 4-4-3501-1
2	1610	2.250-10	3.500	5.750	EY 5-4-4961
2	1610	2.250-10	3.500	5.750	EY 5-4-4961-1
2	1710	2.250-10	3.500	5.250	EY 6-4-2141
2	1710	2.250-10	3.500	5.250	EY 6-4-6861
2	1710	2.250-10	3.500	5.250	EY 6-4-6861-1
2	1710	2.250-10	3.500	5.250	EY 6-4-6901-1X
2	1710	2.250-10	3.500	5.250	EY 6-4-6901X
2	1760	2.250-10	3.500	5.656	EY 6.3-4-701-1
2	1810	2.250-10	3.500	5.844	EY 6.5-4-2021

3-E-92					
1	1610	2.250-10	3.500	3.625	CF 5-1-6331
1	1710	2.250-10	3.500	3.688	CF 6-1-951
1	1810	2.250-10	3.500	3.688	CF 6.5-1-151
1	1550	2.250-10	3.500	5.125	EY 4-4-3501-1
1	1610	2.250-10	3.500	5.750	EY 5-4-4961
1	1610	2.250-10	3.500	5.750	EY 5-4-4961-1
1	1710	2.250-10	3.500	5.250	EY 6-4-2141
1	1710	2.250-10	3.500	5.250	EY 6-4-6861
1	1710	2.250-10	3.500	5.250	EY 6-4-6861-1
1	1710	2.250-10	3.500	5.250	EY 6-4-6901-1X
1	1710	2.250-10	3.500	5.250	EY 6-4-6901X
1	1760	2.250-10	3.500	5.656	EY 6.3-4-701-1
1	1810	2.250-10	3.500	5.844	EY 6.5-4-2021
2	1610	2.250-10	3.500	3.625	CF 5-1-6331
2	1710	2.250-10	3.500	3.688	CF 6-1-951
2	1810	2.250-10	3.500	3.688	CF 6.5-1-151
2	1550	2.250-10	3.500	5.125	EY 4-4-3501-1
2	1610	2.250-10	3.500	5.750	EY 5-4-4961
2	1610	2.250-10	3.500	5.750	EY 5-4-4961-1
2	1710	2.250-10	3.500	5.250	EY 6-4-2141
2	1710	2.250-10	3.500	5.250	EY 6-4-6861
2	1710	2.250-10	3.500	5.250	EY 6-4-6861-1
2	1710	2.250-10	3.500	5.250	EY 6-4-6901-1X
2	1710	2.250-10	3.500	5.250	EY 6-4-6901X
2	1760	2.250-10	3.500	5.656	EY 6.3-4-701-1
2	1810	2.250-10	3.500	5.844	EY 6.5-4-2021

3-F-65					
1	1610	2.000-10	3.250	3.625	CF 5-1-931
1	1710	2.000-10	3.250	5.625	EY 6-4-2001
2	1610	2.250-10	3.500	3.625	CF 5-1-6331
2	1710	2.250-10	3.500	3.688	CF 6-1-951
2	1810	2.250-10	3.500	3.688	CF 6.5-1-151
2	1550	2.250-10	3.500	5.125	EY 4-4-3501-1
2	1610	2.250-10	3.500	5.750	EY 5-4-4961
2	1610	2.250-10	3.500	5.750	EY 5-4-4961-1
2	1710	2.250-10	3.500	5.250	EY 6-4-2141
2	1710	2.250-10	3.500	5.250	EY 6-4-6861
2	1710	2.250-10	3.500	5.250	EY 6-4-6861-1
2	1710	2.250-10	3.500	5.250	EY 6-4-6901-1X
2	1710	2.250-10	3.500	5.250	EY 6-4-6901X
2	1760	2.250-10	3.500	5.656	EY 6.3-4-701-1
2	1810	2.250-10	3.500	5.844	EY 6.5-4-2021

Pos	Series	Spline Data	Hub Dia	* to End of Hub	End Fitting Part Number
3-F-92					
1	1610	2.250-10	3.500	3.625	CF 5-1-6331
1	1710	2.250-10	3.500	3.688	CF 6-1-951
1	1810	2.250-10	3.500	3.688	CF 6.5-1-151
1	1550	2.250-10	3.500	5.125	EY 4-4-3501-1
1	1610	2.250-10	3.500	5.750	EY 5-4-4961
1	1610	2.250-10	3.500	5.750	EY 5-4-4961-1
1	1710	2.250-10	3.500	5.250	EY 6-4-2141
1	1710	2.250-10	3.500	5.250	EY 6-4-6861
1	1710	2.250-10	3.500	5.250	EY 6-4-6861-1
1	1710	2.250-10	3.500	5.250	EY 6-4-6901-1X
1	1710	2.250-10	3.500	5.250	EY 6-4-6901X
1	1760	2.250-10	3.500	5.656	EY 6.3-4-701-1
1	1810	2.250-10	3.500	5.844	EY 6.5-4-2021
2	1610	2.250-10	3.500	3.625	CF 5-1-6331
2	1710	2.250-10	3.500	3.688	CF 6-1-951
2	1810	2.250-10	3.500	3.688	CF 6.5-1-151
2	1550	2.250-10	3.500	5.125	EY 4-4-3501-1
2	1610	2.250-10	3.500	5.750	EY 5-4-4961
2	1610	2.250-10	3.500	5.750	EY 5-4-4961-1
2	1710	2.250-10	3.500	5.250	EY 6-4-2141
2	1710	2.250-10	3.500	5.250	EY 6-4-6861
2	1710	2.250-10	3.500	5.250	EY 6-4-6861-1
2	1710	2.250-10	3.500	5.250	EY 6-4-6901-1X
2	1710	2.250-10	3.500	5.250	EY 6-4-6901X
2	1760	2.250-10	3.500	5.656	EY 6.3-4-701-1
2	1810	2.250-10	3.500	5.844	EY 6.5-4-2021

3-G-65					
1	1610	2.000-10	3.250	3.625	CF 5-1-931
1	1710	2.000-10	3.250	5.625	EY 6-4-2001
2	1610	2.250-10	3.500	3.625	CF 5-1-6331
2	1710	2.250-10	3.500	3.688	CF 6-1-951
2	1810	2.250-10	3.500	3.688	CF 6.5-1-151
2	1550	2.250-10	3.500	5.125	EY 4-4-3501-1
2	1610	2.250-10	3.500	5.750	EY 5-4-4961
2	1610	2.250-10	3.500	5.750	EY 5-4-4961-1
2	1710	2.250-10	3.500	5.250	EY 6-4-2141
2	1710	2.250-10	3.500	5.250	EY 6-4-6861
2	1710	2.250-10	3.500	5.250	EY 6-4-6861-1
2	1710	2.250-10	3.500	5.250	EY 6-4-6901-1X
2	1710	2.250-10	3.500	5.250	EY 6-4-6901X
2	1760	2.250-10	3.500	5.656	EY 6.3-4-701-1
2	1810	2.250-10	3.500	5.844	EY 6.5-4-2021

3-G-92					
1	1610	2.250-10	3.500	3.625	CF 5-1-6331
1	1710	2.250-10	3.500	3.688	CF 6-1-951
1	1810	2.250-10	3.500	3.688	CF 6.5-1-151
1	1550	2.250-10	3.500	5.125	EY 4-4-3501-1
1	1610	2.250-10	3.500	5.750	EY 5-4-4961
1	1610	2.250-10	3.500	5.750	EY 5-4-4961-1
1	1710	2.250-10	3.500	5.250	EY 6-4-2141
1	1710	2.250-10	3.500	5.250	EY 6-4-6861
1	1710	2.250-10	3.500	5.250	EY 6-4-6861-1
1	1710	2.250-10	3.500	5.250	EY 6-4-6901-1X
1	1710	2.250-10	3.500	5.250	EY 6-4-6901X
1	1760	2.250-10	3.500	5.656	EY 6.3-4-701-1
1	1810	2.250-10	3.500	5.844	EY 6.5-4-2021

Continued on next page

*C/L to End of Hub for EY (End Yoke); Flange Face to End of Hub for CF (Companion Flange)

■ Hub machined for speedometer gear



Important: See Safety Information in General Information Section (J300P-GI)

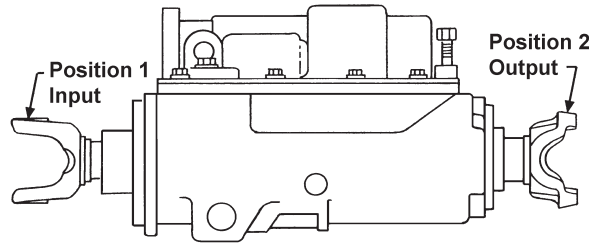

Pos	Series	Spline Data	Hub Dia	* to End of Hub	End Fitting Part Number
-----	--------	-------------	---------	-----------------	-------------------------

3-G-92 (Continued)

2	1610	2.250-10	3.500	3.625	CF 5-1-6331
2	1710	2.250-10	3.500	3.688	CF 6-1-951
2	1810	2.250-10	3.500	3.688	CF 6.5-1-151
2	1550	2.250-10	3.500	5.125	EY 4-4-3501-1
2	1610	2.250-10	3.500	5.750	EY 5-4-4961
2	1610	2.250-10	3.500	5.750	EY 5-4-4961-1
2	1710	2.250-10	3.500	5.250	EY 6-4-2141
2	1710	2.250-10	3.500	5.250	EY 6-4-6861
2	1710	2.250-10	3.500	5.250	EY 6-4-6861-1
2	1710	2.250-10	3.500	5.250	EY 6-4-6901-1X
2	1710	2.250-10	3.500	5.250	EY 6-4-6901X
2	1760	2.250-10	3.500	5.656	EY 6.3-4-701-1
2	1810	2.250-10	3.500	5.844	EY 6.5-4-2021

3-H-65

1	1610	2.000-10	3.250	3.625	CF 5-1-931
1	1710	2.000-10	3.250	5.625	EY 6-4-2001
2	1610	2.250-10	3.500	3.625	CF 5-1-6331
2	1710	2.250-10	3.500	3.688	CF 6-1-951
2	1810	2.250-10	3.500	3.688	CF 6.5-1-151
2	1550	2.250-10	3.500	5.125	EY 4-4-3501-1
2	1610	2.250-10	3.500	5.750	EY 5-4-4961
2	1610	2.250-10	3.500	5.750	EY 5-4-4961-1
2	1710	2.250-10	3.500	5.250	EY 6-4-2141
2	1710	2.250-10	3.500	5.250	EY 6-4-6861
2	1710	2.250-10	3.500	5.250	EY 6-4-6861-1
2	1710	2.250-10	3.500	5.250	EY 6-4-6901-1X
2	1710	2.250-10	3.500	5.250	EY 6-4-6901X
2	1760	2.250-10	3.500	5.656	EY 6.3-4-701-1
2	1810	2.250-10	3.500	5.844	EY 6.5-4-2021

3-H-92, 3-TA-92, 3-TC-92

1	1610	2.250-10	3.500	3.625	CF 5-1-6331
1	1710	2.250-10	3.500	3.688	CF 6-1-951
1	1810	2.250-10	3.500	3.688	CF 6.5-1-151
1	1550	2.250-10	3.500	5.125	EY 4-4-3501-1
1	1610	2.250-10	3.500	5.750	EY 5-4-4961
1	1610	2.250-10	3.500	5.750	EY 5-4-4961-1
1	1710	2.250-10	3.500	5.250	EY 6-4-2141
1	1710	2.250-10	3.500	5.250	EY 6-4-6861
1	1710	2.250-10	3.500	5.250	EY 6-4-6861-1
1	1710	2.250-10	3.500	5.250	EY 6-4-6901-1X
1	1710	2.250-10	3.500	5.250	EY 6-4-6901X
1	1760	2.250-10	3.500	5.656	EY 6.3-4-701-1
1	1810	2.250-10	3.500	5.844	EY 6.5-4-2021
2	1610	2.250-10	3.500	3.625	CF 5-1-6331
2	1710	2.250-10	3.500	3.688	CF 6-1-951
2	1810	2.250-10	3.500	3.688	CF 6.5-1-151
2	1550	2.250-10	3.500	5.125	EY 4-4-3501-1
2	1610	2.250-10	3.500	5.750	EY 5-4-4961
2	1610	2.250-10	3.500	5.750	EY 5-4-4961-1
2	1710	2.250-10	3.500	5.250	EY 6-4-2141

Pos	Series	Spline Data	Hub Dia	* to End of Hub	End Fitting Part Number
-----	--------	-------------	---------	-----------------	-------------------------

3-H-92, 3-TA-92, 3-TC-92 (Continued)

2	1710	2.250-10	3.500	5.250	EY 6-4-6861
2	1710	2.250-10	3.500	5.250	EY 6-4-6861-1
2	1710	2.250-10	3.500	5.250	EY 6-4-6901-1X
2	1710	2.250-10	3.500	5.250	EY 6-4-6901X
2	1760	2.250-10	3.500	5.656	EY 6.3-4-701-1
2	1810	2.250-10	3.500	5.844	EY 6.5-4-2021

3-TD-92

1	1610	2.250-10	3.500	3.625	CF 5-1-6331
1	1710	2.250-10	3.500	3.688	CF 6-1-951
1	1810	2.250-10	3.500	3.688	CF 6.5-1-151
1	1610	2.250-10	3.500	5.750	EY 5-4-4961
1	1610	2.250-10	3.500	5.750	EY 5-4-4961-1
1	1710	2.250-10	3.500	5.250	EY 6-4-2141
1	1710	2.250-10	3.500	5.250	EY 6-4-6861
1	1710	2.250-10	3.500	5.250	EY 6-4-6861-1
1	1710	2.250-10	3.500	5.250	EY 6-4-6901-1X
1	1710	2.250-10	3.500	5.250	EY 6-4-6901X
1	1760	2.250-10	3.500	5.656	EY 6.3-4-701-1
1	1810	2.250-10	3.500	5.844	EY 6.5-4-2021
2	1610	2.250-10	3.500	3.625	CF 5-1-6331
2	1710	2.250-10	3.500	3.688	CF 6-1-951
2	1810	2.250-10	3.500	3.688	CF 6.5-1-151
2	1550	2.250-10	3.500	5.125	EY 4-4-3501-1
2	1610	2.250-10	3.500	5.750	EY 5-4-4961
2	1610	2.250-10	3.500	5.750	EY 5-4-4961-1
2	1710	2.250-10	3.500	5.250	EY 6-4-2141
2	1710	2.250-10	3.500	5.250	EY 6-4-6861
2	1710	2.250-10	3.500	5.250	EY 6-4-6861-1
2	1710	2.250-10	3.500	5.250	EY 6-4-6901-1X
2	1710	2.250-10	3.500	5.250	EY 6-4-6901X
2	1760	2.250-10	3.500	5.656	EY 6.3-4-701-1
2	1810	2.250-10	3.500	5.844	EY 6.5-4-2021

3K65, 3L65, 3M65, 3P65, 3Q65

1	1610	2.250-10	3.500	5.750	EY 5-4-4961
---	------	----------	-------	-------	-------------

4 SP. 75

2	1610	2.250-10	3.500	3.625	CF 5-1-6331
2	1810	2.250-10	3.500	3.688	CF 6.5-1-151
2	SPL170	2.250-10	3.500	5.750	EY 170-4-451-1
2	SPL170	2.250-10	3.500	5.750	EY 170-4-461-1X
2	SPL90	2.250-10	3.500	5.219	EY 90-4-151-1X
2	SPL90	2.250-10	3.500	5.219	EY 90-4-401-1
2	1550	2.250-10	3.500	5.125	EY 4-4-3501-1
2	1610	2.250-10	3.500	5.750	EY 5-4-4961
2	1610	2.250-10	3.500	5.750	EY 5-4-4961-1
2	1710	2.250-10	3.500	5.250	EY 6-4-6861
2	1710	2.250-10	3.500	5.250	EY 6-4-6861-1
2	1710	2.250-10	3.500	5.250	EY 6-4-6901-1X
2	1760	2.250-10	3.500	5.656	EY 6.3-4-761-1X
2	1810	2.250-10	3.500	5.844	EY 6.5-4-2021

*C/L to End of Hub for EY (End Yoke); Flange Face to End of Hub for CF (Companion Flange)

■ Hub machined for speedometer gear



Pos	Series	Spline Data	Hub Dia	* to End of Hub	End Fitting Part Number
4-B-73					
1	1610	2.250-10	3.500	3.625	CF 5-1-6331
1	1710	2.250-10	3.500	3.688	CF 6-1-951
1	1810	2.250-10	3.500	3.688	CF 6.5-1-151
1	1550	2.250-10	3.500	5.125	EY 4-4-3501-1
1	1610	2.250-10	3.500	5.750	EY 5-4-4961
1	1610	2.250-10	3.500	5.750	EY 5-4-4961-1
1	1710	2.250-10	3.500	5.250	EY 6-4-2141
1	1710	2.250-10	3.500	5.250	EY 6-4-6861
1	1710	2.250-10	3.500	5.250	EY 6-4-6861-1
1	1710	2.250-10	3.500	5.250	EY 6-4-6901-1X
1	1710	2.250-10	3.500	5.250	EY 6-4-6901X
1	1760	2.250-10	3.500	5.656	EY 6.3-4-701-1
1	1810	2.250-10	3.500	5.844	EY 6.5-4-2021
2	1610	2.250-10	3.500	3.625	CF 5-1-6331
2	1710	2.250-10	3.500	3.688	CF 6-1-951
2	1810	2.250-10	3.500	3.688	CF 6.5-1-151
2	1610	2.250-10	3.500	5.750	EY 5-4-4961
2	1610	2.250-10	3.500	5.750	EY 5-4-4961-1
2	1710	2.250-10	3.500	5.250	EY 6-4-2141
2	1710	2.250-10	3.500	5.250	EY 6-4-6861
2	1710	2.250-10	3.500	5.250	EY 6-4-6861-1
2	1710	2.250-10	3.500	5.250	EY 6-4-6901-1X
2	1710	2.250-10	3.500	5.250	EY 6-4-6901X
2	1760	2.250-10	3.500	5.656	EY 6.3-4-701-1
2	1810	2.250-10	3.500	5.844	EY 6.5-4-2021

4-B-75					
1	1610	2.250-10	3.500	3.625	CF 5-1-6331
1	1710	2.250-10	3.500	3.688	CF 6-1-951
1	1810	2.250-10	3.500	3.688	CF 6.5-1-151
1	1550	2.250-10	3.500	5.125	EY 4-4-3501-1
1	1610	2.250-10	3.500	5.750	EY 5-4-4961
1	1610	2.250-10	3.500	5.750	EY 5-4-4961-1
1	1710	2.250-10	3.500	5.250	EY 6-4-2141
1	1710	2.250-10	3.500	5.250	EY 6-4-6861
1	1710	2.250-10	3.500	5.250	EY 6-4-6861-1
1	1710	2.250-10	3.500	5.250	EY 6-4-6901-1X
1	1710	2.250-10	3.500	5.250	EY 6-4-6901X
1	1760	2.250-10	3.500	5.656	EY 6.3-4-701-1
1	1810	2.250-10	3.500	5.844	EY 6.5-4-2021
2	1610	2.250-10	3.500	3.625	CF 5-1-6331
2	1710	2.250-10	3.500	3.688	CF 6-1-951
2	1810	2.250-10	3.500	3.688	CF 6.5-1-151
2	1550	2.250-10	3.500	5.125	EY 4-4-3501-1
2	1610	2.250-10	3.500	5.750	EY 5-4-4961
2	1610	2.250-10	3.500	5.750	EY 5-4-4961-1
2	1710	2.250-10	3.500	5.250	EY 6-4-2141
2	1710	2.250-10	3.500	5.250	EY 6-4-6861
2	1710	2.250-10	3.500	5.250	EY 6-4-6861-1
2	1710	2.250-10	3.500	5.250	EY 6-4-6901-1X
2	1710	2.250-10	3.500	5.250	EY 6-4-6901X
2	1760	2.250-10	3.500	5.656	EY 6.3-4-701-1
2	1810	2.250-10	3.500	5.844	EY 6.5-4-2021

4-C-75					
1	1610	2.250-10	3.500	3.625	CF 5-1-6331
1	1710	2.250-10	3.500	3.688	CF 6-1-951
1	1810	2.250-10	3.500	3.688	CF 6.5-1-151
1	1550	2.250-10	3.500	5.125	EY 4-4-3501-1

Pos	Series	Spline Data	Hub Dia	* to End of Hub	End Fitting Part Number
4-C-75 (Continued)					
1	1610	2.250-10	3.500	5.750	EY 5-4-4961
1	1610	2.250-10	3.500	5.750	EY 5-4-4961-1
1	1710	2.250-10	3.500	5.250	EY 6-4-2141
1	1710	2.250-10	3.500	5.250	EY 6-4-6861
1	1710	2.250-10	3.500	5.250	EY 6-4-6861-1
1	1710	2.250-10	3.500	5.250	EY 6-4-6901-1X
1	1710	2.250-10	3.500	5.250	EY 6-4-6901X
1	1760	2.250-10	3.500	5.656	EY 6.3-4-701-1
1	1810	2.250-10	3.500	5.844	EY 6.5-4-2021
2	1610	2.250-10	3.500	3.625	CF 5-1-6331
2	1710	2.250-10	3.500	3.688	CF 6-1-951
2	1810	2.250-10	3.500	3.688	CF 6.5-1-151
2	1610	2.250-10	3.500	5.750	EY 5-4-4961
2	1610	2.250-10	3.500	5.750	EY 5-4-4961-1
2	1710	2.250-10	3.500	5.250	EY 6-4-2141
2	1710	2.250-10	3.500	5.250	EY 6-4-6861
2	1710	2.250-10	3.500	5.250	EY 6-4-6861-1
2	1710	2.250-10	3.500	5.250	EY 6-4-6901-1X
2	1710	2.250-10	3.500	5.250	EY 6-4-6901X
2	1760	2.250-10	3.500	5.656	EY 6.3-4-701-1
2	1810	2.250-10	3.500	5.844	EY 6.5-4-2021

4-D-75, 4-E-75					
1	1610	2.250-10	3.500	3.625	CF 5-1-6331
1	1710	2.250-10	3.500	3.688	CF 6-1-951
1	1810	2.250-10	3.500	3.688	CF 6.5-1-151
1	1550	2.250-10	3.500	5.125	EY 4-4-3501-1
1	1610	2.250-10	3.500	5.750	EY 5-4-4961
1	1610	2.250-10	3.500	5.750	EY 5-4-4961-1
1	1710	2.250-10	3.500	5.250	EY 6-4-2141
1	1710	2.250-10	3.500	5.250	EY 6-4-6861
1	1710	2.250-10	3.500	5.250	EY 6-4-6861-1
1	1710	2.250-10	3.500	5.250	EY 6-4-6901-1X
1	1710	2.250-10	3.500	5.250	EY 6-4-6901X
1	1760	2.250-10	3.500	5.656	EY 6.3-4-701-1
1	1810	2.250-10	3.500	5.844	EY 6.5-4-2021
2	1610	2.250-10	3.500	3.625	CF 5-1-6331
2	1710	2.250-10	3.500	3.688	CF 6-1-951
2	1810	2.250-10	3.500	3.688	CF 6.5-1-151
2	1550	2.250-10	3.500	5.125	EY 4-4-3501-1
2	1610	2.250-10	3.500	5.750	EY 5-4-4961
2	1610	2.250-10	3.500	5.750	EY 5-4-4961-1
2	1710	2.250-10	3.500	5.250	EY 6-4-2141
2	1710	2.250-10	3.500	5.250	EY 6-4-6861
2	1710	2.250-10	3.500	5.250	EY 6-4-6861-1
2	1710	2.250-10	3.500	5.250	EY 6-4-6901-1X
2	1710	2.250-10	3.500	5.250	EY 6-4-6901X
2	1760	2.250-10	3.500	5.656	EY 6.3-4-701-1
2	1810	2.250-10	3.500	5.844	EY 6.5-4-2021

4-F-1440, 4-MB-1440					
2	1810	2.750-10	3.750	4.062	CF 6.5-1-2311
2	1810	2.750-10	3.750	4.062	CF 6.5-1-2361X
2	SPL140	2.750-10	3.750	6.570	EY 140-4-81-1
2	SPL140	2.750-10	3.750	6.570	EY 140-4-91-1X
2	SPL170	2.750-10	3.750	5.850	EY 170-4-511-1
2	SPL170	2.750-10	3.750	5.850	EY 170-4-521-1X
2	SPL250	2.750-10	3.750	6.297	EY 250-4-231-1

Continued on next page

*C/L to End of Hub for EY (End Yoke); Flange Face to End of Hub for CF (Companion Flange)

■ Hub machined for speedometer gear



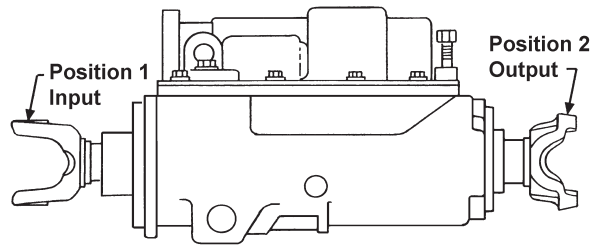

Pos	Series	Spline Data	Hub Dia	* to End of Hub	End Fitting Part Number
-----	--------	-------------	---------	-----------------	-------------------------

Pos	Series	Spline Data	Hub Dia	* to End of Hub	End Fitting Part Number
-----	--------	-------------	---------	-----------------	-------------------------

4-F-1440, 4-MB-1440 (Continued)

2	SPL250	2.750-10	3.750	6.297	EY 250-4-241-1X
2	1710	2.750-10	3.750	5.750	EY 6-4-6821
2	1710	2.750-10	3.750	5.750	EY 6-4-6821-1
2	1710	2.750-10	3.750	5.750	EY 6-4-6931-1X
2	1710	2.750-10	3.750	5.750	EY 6-4-6931X
2	1760	2.750-10	3.750	5.969	EY 6.3-4-711
2	1760	2.750-10	3.750	5.969	EY 6.3-4-711-1
2	1760	2.750-10	3.750	5.969	EY 6.3-4-791-1X
2	1760	2.750-10	3.750	5.969	EY 6.3-4-791X
2	1810	2.750-10	3.750	6.062	EY 6.5-4-3491
2	1810	2.750-10	3.750	6.062	EY 6.5-4-3491-1
2	1810	2.750-10	3.750	6.062	EY 6.5-4-3561-1X
2	1810	2.750-10	3.750	6.062	EY 6.5-4-3561X

4-MS-1440

2	1810	2.750-10	3.750	4.062	CF 6.5-1-2311
2	1810	2.750-10	3.750	4.062	CF 6.5-1-2361X
2	SPL140	2.750-10	3.750	6.570	EY 140-4-81-1
2	SPL140	2.750-10	3.750	6.570	EY 140-4-91-1X
2	SPL170	2.750-10	3.750	5.850	EY 170-4-511-1
2	SPL170	2.750-10	3.750	5.850	EY 170-4-521-1X
2	SPL250	2.750-10	3.750	6.297	EY 250-4-231-1
2	SPL250	2.750-10	3.750	6.297	EY 250-4-241-1X
2	1710	2.750-10	3.750	5.750	EY 6-4-6821
2	1710	2.750-10	3.750	5.750	EY 6-4-6821-1
2	1760	2.750-10	3.750	5.969	EY 6.3-4-711
2	1760	2.750-10	3.750	5.969	EY 6.3-4-711-1
2	1760	2.750-10	3.750	5.969	EY 6.3-4-791-1X
2	1760	2.750-10	3.750	5.969	EY 6.3-4-791X
2	1810	2.750-10	3.750	6.062	EY 6.5-4-3491
2	1810	2.750-10	3.750	6.062	EY 6.5-4-3491-1
2	1810	2.750-10	3.750	6.062	EY 6.5-4-3561-1X
2	1810	2.750-10	3.750	6.062	EY 6.5-4-3561X

461

1	SPL170	2.143-41	2.938	7.190	EY 170-4-1861-1X
---	--------	----------	-------	-------	------------------

*C/L to End of Hub for EY (End Yoke); Flange Face to End of Hub for CF (Companion Flange)

■ Hub machined for speedometer gear



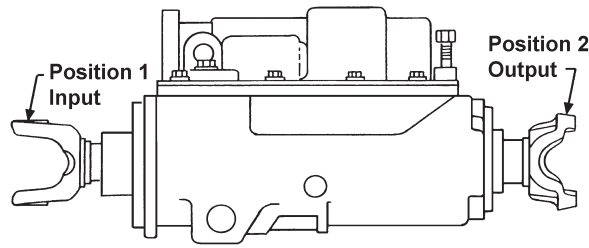

Pos	Series	Spline Data	Hub Dia	* to End of Hub	End Fitting Part Number
-----	--------	-------------	---------	-----------------	-------------------------

AMO610-4

1	1710	2.225-6	3.000	3.750	CF 6-1-1731
1	1810	2.225-6	3.000	3.750	CF 6.5-1-481
1	SPL250	2.225-6	3.000	6.240	EY 250-4-531-1
1	SPL250	2.225-6	3.000	6.240	EY 250-4-541-1X
1	1610	2.225-6	3.000	5.719	EY 5-4-4741
1	1610	2.225-6	3.000	5.719	EY 5-4-4751X
1	1710	2.225-6	3.000	5.312	EY 6-4-3031
1	1710	2.225-6	3.000	5.438	EY 6-4-3031-1
1	1710	2.225-6	3.000	5.438	EY 6-4-3041-1X
1	1710	2.225-6	3.000	5.312	EY 6-4-3041X
1	1760	2.225-6	3.000	6.000	EY 6.3-4-171-1X
1	1760	2.225-6	3.000	6.000	EY 6.3-4-171X
1	1760	2.225-6	3.000	6.000	EY 6.3-4-51
1	1760	2.225-6	3.000	6.000	EY 6.3-4-51-1
1	1810	2.225-6	3.000	6.000	EY 6.5-4-1971
1	1810	2.225-6	3.000	6.000	EY 6.5-4-1971-1
1	1810	2.225-6	3.000	6.000	EY 6.5-4-2271X
2	1710	2.225-6	3.000	3.750	CF 6-1-1731
2	1810	2.225-6	3.000	3.750	CF 6.5-1-481
2	SPL250	2.225-6	3.000	6.240	EY 250-4-531-1
2	SPL250	2.225-6	3.000	6.240	EY 250-4-541-1X
2	1610	2.225-6	3.000	5.719	EY 5-4-4741
2	1610	2.225-6	3.000	5.719	EY 5-4-4751X
2	1710	2.225-6	3.000	5.312	EY 6-4-3031
2	1710	2.225-6	3.000	5.438	EY 6-4-3031-1
2	1710	2.225-6	3.000	5.438	EY 6-4-3041-1X
2	1710	2.225-6	3.000	5.312	EY 6-4-3041X
2	1760	2.225-6	3.000	6.000	EY 6.3-4-171-1X
2	1760	2.225-6	3.000	6.000	EY 6.3-4-171X
2	1760	2.225-6	3.000	6.000	EY 6.3-4-51
2	1760	2.225-6	3.000	6.000	EY 6.3-4-51-1
2	1810	2.225-6	3.000	6.000	EY 6.5-4-1971
2	1810	2.225-6	3.000	6.000	EY 6.5-4-1971-1
2	1810	2.225-6	3.000	6.000	EY 6.5-4-2271X

AMO610-4L

1	SPL250	2.225-6	3.000	6.240	EY 250-4-541-1X
2	SPL250	2.225-6	3.000	6.240	EY 250-4-541-1X

AMO610-6

1	1710	2.225-6	3.000	3.750	CF 6-1-1731
1	1810	2.225-6	3.000	3.750	CF 6.5-1-481
1	SPL250	2.225-6	3.000	6.240	EY 250-4-531-1
1	SPL250	2.225-6	3.000	6.240	EY 250-4-541-1X
1	1610	2.225-6	3.000	5.719	EY 5-4-4741
1	1610	2.225-6	3.000	5.719	EY 5-4-4751X
1	1710	2.225-6	3.000	5.312	EY 6-4-3031
1	1710	2.225-6	3.000	5.438	EY 6-4-3031-1
1	1710	2.225-6	3.000	5.438	EY 6-4-3041-1X
1	1710	2.225-6	3.000	5.312	EY 6-4-3041X
1	1760	2.225-6	3.000	6.000	EY 6.3-4-171-1X

Pos	Series	Spline Data	Hub Dia	* to End of Hub	End Fitting Part Number
-----	--------	-------------	---------	-----------------	-------------------------

AMO610-6 (Continued)

1	1760	2.225-6	3.000	6.000	EY 6.3-4-171X
1	1760	2.225-6	3.000	6.000	EY 6.3-4-51
1	1760	2.225-6	3.000	6.000	EY 6.3-4-51-1
1	1810	2.225-6	3.000	6.000	EY 6.5-4-1971
1	1810	2.225-6	3.000	6.000	EY 6.5-4-1971-1
1	1810	2.225-6	3.000	6.000	EY 6.5-4-2271X
2	1710	2.225-6	3.000	3.750	CF 6-1-1731
2	1810	2.225-6	3.000	3.750	CF 6.5-1-481
2	SPL250	2.225-6	3.000	6.240	EY 250-4-531-1
2	SPL250	2.225-6	3.000	6.240	EY 250-4-541-1X
2	1610	2.225-6	3.000	5.719	EY 5-4-4741
2	1610	2.225-6	3.000	5.719	EY 5-4-4751X
2	1710	2.225-6	3.000	5.312	EY 6-4-3031
2	1710	2.225-6	3.000	5.438	EY 6-4-3031-1
2	1710	2.225-6	3.000	5.438	EY 6-4-3041-1X
2	1710	2.225-6	3.000	5.312	EY 6-4-3041X
2	1760	2.225-6	3.000	6.000	EY 6.3-4-171-1X
2	1760	2.225-6	3.000	6.000	EY 6.3-4-171X
2	1760	2.225-6	3.000	6.000	EY 6.3-4-51
2	1760	2.225-6	3.000	6.000	EY 6.3-4-51-1
2	1810	2.225-6	3.000	6.000	EY 6.5-4-1971
2	1810	2.225-6	3.000	6.000	EY 6.5-4-1971-1
2	1810	2.225-6	3.000	6.000	EY 6.5-4-2271X

AMO1000-4

1	SPL170	2.635-20	3.750	6.020	EY 170-4-1101-1■ <i>Grnd.hub Dia. 3.000, if used on Spicer 1241 Aux. Trans.</i>
1	SPL170	2.635-20	3.750	6.020	EY 170-4-1111-1X■ <i>Grnd.hub Dia. 3.000, if used on Spicer 1241 Aux. Trans.</i>
1	SPL250	2.635-20	3.750	6.270	EY 250-4-511-1■ <i>Grnd.hub Dia. 3.000, if used on Spicer 1241 Aux. Trans.</i>
1	SPL250	2.635-20	3.750	6.270	EY 250-4-521-1X■ <i>Grnd.hub Dia. 3.000, if used on Spicer 1241 Aux. Trans.</i>
1	1710	2.635-20	3.750	5.188	EY 6-4-5351■
1	1710	2.635-20	3.750	5.188	EY 6-4-5351-1■
1	1710	2.635-20	3.750	5.188	EY 6-4-7071-1X■ <i>Grnd.hub Dia. 3.000, if used on Spicer 1241 Aux. Trans.</i>
1	1710	2.635-20	3.750	5.188	EY 6-4-7071X■ <i>Grnd.hub Dia. 3.000, if used on Spicer 1241 Aux. Trans.</i>
1	1760	2.635-20	3.750	5.562	EY 6.3-4-41■ <i>Grnd.hub Dia. 3.000, if used on Spicer 1241 Aux. Trans.</i>
1	1760	2.635-20	3.750	5.562	EY 6.3-4-41-1■ <i>Grnd.hub Dia. 3.000, if used on Spicer 1241 Aux. Trans.</i>
1	1760	2.635-20	3.750	5.562	EY 6.3-4-871-1X■ <i>Grnd.hub Dia. 3.000, if used on Spicer 1241 Aux. Trans.</i>
1	1760	2.635-20	3.750	5.562	EY 6.3-4-871X■ <i>Grnd.hub Dia. 3.000, if used on Spicer 1241 Aux. Trans.</i>
1	1810	2.635-20	3.750	5.562	EY 6.5-4-3021■ <i>Grnd.hub Dia. 3.000, if used on Spicer 1241 Aux. Trans.</i>
1	1810	2.635-20	3.750	5.562	EY 6.5-4-3021-1■ <i>Grnd.hub Dia. 3.000, if used on Spicer 1241 Aux. Trans.</i>

Continued on next page

*C/L to End of Hub for EY (End Yoke); Flange Face to End of Hub for CF (Companion Flange)

■ Hub machined for speedometer gear



Important: See Safety Information in General Information Section (J300P-GI)

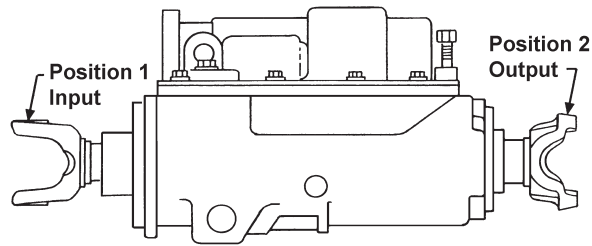

Pos	Series	Spline Data	Hub Dia	* to End of Hub	End Fitting Part Number
-----	--------	-------------	---------	-----------------	-------------------------

AMO1000-4 (Continued)

1	1810	2.635-20	3.750	5.562	EY 6.5-4-3541-1X■ <i>Grnd.hub Dia. 3.000, if used on Spicer 1241 Aux. Trans.</i>
1	1810	2.635-20	3.750	5.562	EY 6.5-4-3541X■ <i>Grnd.hub Dia. 3.000, if used on Spicer 1241 Aux. Trans.</i>
1	1880	2.625-20	3.000	6.270	EY 8-4-1231
2	1810	2.750-10	4.000	3.750	CF 6.5-1-1871■
2	SPL170	2.750-10	4.000	5.800	EY 170-4-1141-1
2	SPL250	2.750-10	4.000	6.370	EY 250-4-551-1■
2	SPL350	2.750-10	3.375	7.087	EY 350-4-121-1
2	1710	2.750-10	4.000	5.312	EY 6-4-4651■
2	1710	2.750-10	4.000	5.312	EY 6-4-4651-1■
2	1760	2.750-10	4.000	6.000	EY 6.3-4-61■
2	1760	2.750-10	4.000	6.000	EY 6.3-4-61-1■
2	1810	2.750-10	4.000	6.000	EY 6.5-4-2171■
2	1810	2.750-10	4.000	6.000	EY 6.5-4-2171-1■
2	1880	2.750-10	3.375	6.370	EY 8-4-1241

No. 3 woodruff keyway in hub; Snap ring groove in hub

APO1000-4

1	SPL170	2.635-20	3.750	6.020	EY 170-4-1101-1■ <i>Grnd.hub Dia. 3.000, if used on Spicer 1241 Aux. Trans.</i>
1	SPL170	2.635-20	3.750	6.020	EY 170-4-1111-1X■ <i>Grnd.hub Dia. 3.000, if used on Spicer 1241 Aux. Trans.</i>
1	SPL250	2.635-20	3.750	6.270	EY 250-4-511-1■ <i>Grnd.hub Dia. 3.000, if used on Spicer 1241 Aux. Trans.</i>
1	SPL250	2.635-20	3.750	6.270	EY 250-4-521-1X■ <i>Grnd.hub Dia. 3.000, if used on Spicer 1241 Aux. Trans.</i>
1	1710	2.635-20	3.750	5.188	EY 6-4-5351■
1	1710	2.635-20	3.750	5.188	EY 6-4-5351-1■
1	1710	2.635-20	3.750	5.188	EY 6-4-7071-1X■ <i>Grnd.hub Dia. 3.000, if used on Spicer 1241 Aux. Trans.</i>
1	1710	2.635-20	3.750	5.188	EY 6-4-7071X■ <i>Grnd.hub Dia. 3.000, if used on Spicer 1241 Aux. Trans.</i>
1	1760	2.635-20	3.750	5.562	EY 6.3-4-41■ <i>Grnd.hub Dia. 3.000, if used on Spicer 1241 Aux. Trans.</i>
1	1760	2.635-20	3.750	5.562	EY 6.3-4-41-1■ <i>Grnd.hub Dia. 3.000, if used on Spicer 1241 Aux. Trans.</i>
1	1760	2.635-20	3.750	5.562	EY 6.3-4-871-1X■ <i>Grnd.hub Dia. 3.000, if used on Spicer 1241 Aux. Trans.</i>
1	1760	2.635-20	3.750	5.562	EY 6.3-4-871X■ <i>Grnd.hub Dia. 3.000, if used on Spicer 1241 Aux. Trans.</i>
1	1810	2.635-20	3.750	5.562	EY 6.5-4-3021■ <i>Grnd.hub Dia. 3.000, if used on Spicer 1241 Aux. Trans.</i>
1	1810	2.635-20	3.750	5.562	EY 6.5-4-3021-1■ <i>Grnd.hub Dia. 3.000, if used on Spicer 1241 Aux. Trans.</i>
1	1810	2.635-20	3.750	5.562	EY 6.5-4-3541-1X■ <i>Grnd.hub Dia. 3.000, if used on Spicer 1241 Aux. Trans.</i>
1	1810	2.635-20	3.750	5.562	EY 6.5-4-3541X■ <i>Grnd.hub Dia. 3.000, if used on Spicer 1241 Aux. Trans.</i>
2	1810	2.750-10	4.000	3.750	CF 6.5-1-1871■
2	SPL170	2.750-10	4.000	5.800	EY 170-4-1141-1
2	SPL250	2.750-10	4.000	6.370	EY 250-4-551-1■
2	SPL350	2.750-10	3.375	7.087	EY 350-4-121-1

Pos	Series	Spline Data	Hub Dia	* to End of Hub	End Fitting Part Number
-----	--------	-------------	---------	-----------------	-------------------------

APO1000-4 (Continued)

2	1710	2.750-10	4.000	5.312	EY 6-4-4651■
2	1710	2.750-10	4.000	5.312	EY 6-4-4651-1■
2	1760	2.750-10	4.000	6.000	EY 6.3-4-61■
2	1760	2.750-10	4.000	6.000	EY 6.3-4-61-1■
2	1810	2.750-10	4.000	6.000	EY 6.5-4-2171■
2	1810	2.750-10	4.000	6.000	EY 6.5-4-2171-1■

ATO610-4

1	1710	2.225-6	3.000	3.750	CF 6-1-1731
1	1810	2.225-6	3.000	3.750	CF 6.5-1-481
1	SPL250	2.225-6	3.000	6.240	EY 250-4-531-1
1	SPL250	2.225-6	3.000	6.240	EY 250-4-541-1X
1	1610	2.225-6	3.000	5.719	EY 5-4-4741
1	1610	2.225-6	3.000	5.719	EY 5-4-4751X
1	1710	2.225-6	3.000	5.312	EY 6-4-3031
1	1710	2.225-6	3.000	5.438	EY 6-4-3031-1
1	1710	2.225-6	3.000	5.438	EY 6-4-3041-1X
1	1710	2.225-6	3.000	5.312	EY 6-4-3041X
1	1760	2.225-6	3.000	6.000	EY 6.3-4-171-1X
1	1760	2.225-6	3.000	6.000	EY 6.3-4-171X
1	1760	2.225-6	3.000	6.000	EY 6.3-4-51
1	1760	2.225-6	3.000	6.000	EY 6.3-4-51-1
1	1810	2.225-6	3.000	6.000	EY 6.5-4-1971
1	1810	2.225-6	3.000	6.000	EY 6.5-4-1971-1
1	1810	2.225-6	3.000	6.000	EY 6.5-4-2271X
2	1710	2.225-6	3.000	3.750	CF 6-1-1731
2	1810	2.225-6	3.000	3.750	CF 6.5-1-481
2	SPL250	2.225-6	3.000	6.240	EY 250-4-531-1
2	SPL250	2.225-6	3.000	6.240	EY 250-4-541-1X
2	1610	2.225-6	3.000	5.719	EY 5-4-4741
2	1610	2.225-6	3.000	5.719	EY 5-4-4751X
2	1710	2.225-6	3.000	5.312	EY 6-4-3031
2	1710	2.225-6	3.000	5.438	EY 6-4-3031-1
2	1710	2.225-6	3.000	5.438	EY 6-4-3041-1X
2	1710	2.225-6	3.000	5.312	EY 6-4-3041X
2	1760	2.225-6	3.000	6.000	EY 6.3-4-171-1X
2	1760	2.225-6	3.000	6.000	EY 6.3-4-171X
2	1760	2.225-6	3.000	6.000	EY 6.3-4-51
2	1760	2.225-6	3.000	6.000	EY 6.3-4-51-1
2	1810	2.225-6	3.000	6.000	EY 6.5-4-1971
2	1810	2.225-6	3.000	6.000	EY 6.5-4-1971-1
2	1810	2.225-6	3.000	6.000	EY 6.5-4-2271X

ATO610-4L

1	SPL250	2.225-6	3.000	6.240	EY 250-4-541-1X
2	SPL250	2.225-6	3.000	6.240	EY 250-4-541-1X

ATO1000-4

1	SPL170	2.635-20	3.750	6.020	EY 170-4-1101-1■ <i>Grnd.hub Dia. 3.000, if used on Spicer 1241 Aux. Trans.</i>
1	SPL170	2.635-20	3.750	6.020	EY 170-4-1111-1X■ <i>Grnd.hub Dia. 3.000, if used on Spicer 1241 Aux. Trans.</i>

*C/L to End of Hub for EY (End Yoke); Flange Face to End of Hub for CF (Companion Flange)

■ Hub machined for speedometer gear



Pos	Series	Spline Data	Hub Dia	* to End of Hub	End Fitting Part Number
ATO1000-4 (Continued)					
1	SPL250	2.635-20	3.750	6.270	EY 250-4-511-1■ <i>Grnd.hub Dia. 3.000, if used on Spicer 1241 Aux. Trans.</i>
1	SPL250	2.635-20	3.750	6.270	EY 250-4-521-1X■ <i>Grnd.hub Dia. 3.000, if used on Spicer 1241 Aux. Trans.</i>
1	1710	2.635-20	3.750	5.188	EY 6-4-5351■
1	1710	2.635-20	3.750	5.188	EY 6-4-5351-1■
1	1710	2.635-20	3.750	5.188	EY 6-4-7071-1X <i>Grnd.hub Dia. 3.000, if used on Spicer 1241 Aux. Trans.■</i>
1	1710	2.635-20	3.750	5.188	EY 6-4-7071X <i>Grnd.hub Dia. 3.000, if used on Spicer 1241 Aux. Trans.■</i>
1	1760	2.635-20	3.750	5.562	EY 6.3-4-41■ <i>Grnd.hub Dia. 3.000, if used on Spicer 1241 Aux. Trans.</i>
1	1760	2.635-20	3.750	5.562	EY 6.3-4-41-1■ <i>Grnd.hub Dia. 3.000, if used on Spicer 1241 Aux. Trans.</i>
1	1760	2.635-20	3.750	5.562	EY 6.3-4-871-1X■ <i>Grnd.hub Dia. 3.000, if used on Spicer 1241 Aux. Trans.</i>
1	1760	2.635-20	3.750	5.562	EY 6.3-4-871X■ <i>Grnd.hub Dia. 3.000, if used on Spicer 1241 Aux. Trans.</i>
1	1810	2.635-20	3.750	5.562	EY 6.5-4-3021■ <i>Grnd.hub Dia. 3.000, if used on Spicer 1241 Aux. Trans.</i>
1	1810	2.635-20	3.750	5.562	EY 6.5-4-3021-1■ <i>Grnd.hub Dia. 3.000, if used on Spicer 1241 Aux. Trans.</i>
1	1810	2.635-20	3.750	5.562	EY 6.5-4-3541-1X■ <i>Grnd.hub Dia. 3.000, if used on Spicer 1241 Aux. Trans.</i>
1	1810	2.635-20	3.750	5.562	EY 6.5-4-3541X■ <i>Grnd.hub Dia. 3.000, if used on Spicer 1241 Aux. Trans.</i>
2	1810	2.750-10	4.000	3.750	CF 6.5-1-1871■
2	SPL170	2.750-10	4.000	5.800	EY 170-4-1141-1
2	SPL250	2.750-10	4.000	6.370	EY 250-4-551-1■
2	SPL350	2.750-10	3.375	7.087	EY 350-4-121-1
2	1710	2.750-10	4.000	5.312	EY 6-4-4651■
2	1710	2.750-10	4.000	5.312	EY 6-4-4651-1■
2	1760	2.750-10	4.000	6.000	EY 6.3-4-61■
2	1760	2.750-10	4.000	6.000	EY 6.3-4-61-1■
2	1810	2.750-10	4.000	6.000	EY 6.5-4-2171■
2	1810	2.750-10	4.000	6.000	EY 6.5-4-2171-1■
P1241-C, P1241-D					
1	1710	2.225-6	3.000	3.750	CF 6-1-1731
1	1810	2.225-6	3.000	3.750	CF 6.5-1-481
1	1710	2.225-6	3.000	5.312	EY 6-4-3041X
1	1760	2.225-6	3.000	6.000	EY 6.3-4-171-1X
1	1760	2.225-6	3.000	6.000	EY 6.3-4-171X
1	1810	2.225-6	3.000	6.000	EY 6.5-4-2271X
2	1810	2.750-10	4.000	3.750	CF 6.5-1-1871■
2	1710	2.750-10	4.000	5.312	EY 6-4-4651■
2	1710	2.750-10	4.000	5.312	EY 6-4-4651-1■
2	1760	2.750-10	4.000	6.000	EY 6.3-4-61■
2	1760	2.750-10	4.000	6.000	EY 6.3-4-61-1■
2	1810	2.750-10	4.000	6.000	EY 6.5-4-2171■
2	1810	2.750-10	4.000	6.000	EY 6.5-4-2171-1■
RP8341D, R8341-D					
1	1610	2.225-6	3.000	3.875	CF 5-1-2541
1	1710	2.225-6	3.000	4.469	CF 6-1-1481
1	1710	2.225-6	3.000	3.750	CF 6-1-1731
1	1810	2.225-6	3.000	3.750	CF 6.5-1-481
1	1610	2.225-6	3.000	5.719	EY 5-4-4751X
1	1710	2.225-6	3.000	5.312	EY 6-4-3041X
1	1760	2.225-6	3.000	6.000	EY 6.3-4-171-1X
1	1760	2.225-6	3.000	6.000	EY 6.3-4-171X
1	1810	2.225-6	3.000	6.000	EY 6.5-4-2271X

Pos	Series	Spline Data	Hub Dia	* to End of Hub	End Fitting Part Number
RP8341D, R8341-D (Continued)					
2	1610	2.225-6	3.000	3.875	CF 5-1-2541
2	1710	2.225-6	3.000	4.469	CF 6-1-1481
2	1710	2.225-6	3.000	3.750	CF 6-1-1731
2	1810	2.225-6	3.000	3.750	CF 6.5-1-481
2	1610	2.225-6	3.000	5.719	EY 5-4-4751X
2	1710	2.225-6	3.000	5.312	EY 6-4-3041X
2	1760	2.225-6	3.000	6.000	EY 6.3-4-171-1X
2	1760	2.225-6	3.000	6.000	EY 6.3-4-171X
2	1810	2.225-6	3.000	6.000	EY 6.5-4-2271X
1241-C, 1241-D					
1	1710	2.225-6	3.000	3.750	CF 6-1-1731
1	1810	2.225-6	3.000	3.750	CF 6.5-1-481
1	1710	2.225-6	3.000	5.312	EY 6-4-3041X
1	1760	2.225-6	3.000	6.000	EY 6.3-4-171-1X
1	1760	2.225-6	3.000	6.000	EY 6.3-4-171X
1	1760	2.225-6	3.000	6.000	EY 6.3-4-51
1	1760	2.225-6	3.000	6.000	EY 6.3-4-51-1
1	1810	2.225-6	3.000	6.000	EY 6.5-4-2271X
2	1810	2.750-10	4.000	3.750	CF 6.5-1-1871■
2	1710	2.750-10	4.000	5.312	EY 6-4-4651■
2	1710	2.750-10	4.000	5.312	EY 6-4-4651-1■
2	1760	2.750-10	4.000	6.000	EY 6.3-4-61■
2	1760	2.750-10	4.000	6.000	EY 6.3-4-61-1■
2	1810	2.750-10	4.000	6.000	EY 6.5-4-2171■
2	1810	2.750-10	4.000	6.000	EY 6.5-4-2171-1■
5831					
1	1480/1550	1.750-10	2.500	2.875	CF 4-1-3331X <i>Slinger not sold separately</i>
2	1480/1550	1.750-10	2.500	2.875	CF 4-1-3331X <i>Slinger not sold separately</i>
6041, 6231					
1	1480/1550	1.961-6	2.750	3.625	CF 4-1-601
1	1610	1.960-6	2.750	5.000	EY 5-4-2031X
2	1480/1550	1.961-6	2.750	3.625	CF 4-1-601
2	1610	1.960-6	2.750	5.000	EY 5-4-2031X
7041					
1	1480/1550	1.961-6	2.750	3.625	CF 4-1-601
1	1610	1.960-6	2.750	5.000	EY 5-4-2031X
2	1610	2.225-6	3.000	3.875	CF 5-1-2541
2	1650/1710	2.225-6	3.000	3.750	CF 6-1-1731
2	1710	2.225-6	3.000	4.469	CF 6-1-1481
2	1810	2.225-6	3.000	3.750	CF 6.5-1-481
2	SPL170	2.225-6	3.000	6.030	EY 170-4-1441-1
2	SPL250	2.225-6	3.000	6.250	EY 250-4-811-1
2	1610	2.225-6	3.000	5.719	EY 5-4-4751X
2	1710	2.225-6	3.000	5.312	EY 6-4-3041X
2	1810	2.225-6	3.000	6.000	EY 6.5-4-1971
2	1810	2.225-6	3.000	6.000	EY 6.5-4-1971-1
2	1810	2.225-6	3.000	6.000	EY 6.5-4-2271X
2	1810	2.225-6	3.000	6.000	EY 6.5-4-2831X
7231					
1	1480/1550	1.961-6	2.750	3.625	CF 4-1-601
1	1610	1.960-6	2.750	5.000	EY 5-4-2031X
2	1480/1550	1.961-6	2.750	3.625	CF 4-1-601
2	1610	1.960-6	2.750	5.000	EY 5-4-2031X

*C/L to End of Hub for EY (End Yoke); Flange Face to End of Hub for CF (Companion Flange)

■ Hub machined for speedometer gear



Important: See Safety Information in General Information Section (J300P-GI)

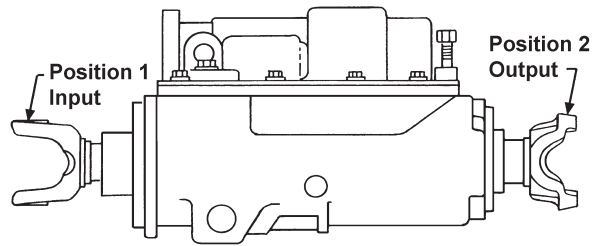

Pos	Series	Spline Data	Hub Dia	* to End of Hub	End Fitting Part Number
-----	--------	-------------	---------	-----------------	-------------------------

8031					
1	1610	2.225-6	3.000	3.875	CF 5-1-2541
1	1650/1710	2.225-6	3.000	4.469	CF 6-1-1481
1	1650/1710	2.225-6	3.000	3.750	CF 6-1-1731
1	1810	2.225-6	3.000	3.750	CF 6.5-1-481
1	1610	2.225-6	3.000	5.719	EY 5-4-4751X
1	1710	2.225-6	3.000	5.312	EY 6-4-3041X
1	1760	2.225-6	3.000	6.000	EY 6.3-4-171-1X
1	1760	2.225-6	3.000	6.000	EY 6.3-4-171X
1	1810	2.225-6	3.000	6.000	EY 6.5-4-2271X
2	1610	2.225-6	3.000	3.875	CF 5-1-2541
2	1650/1710	2.225-6	3.000	4.469	CF 6-1-1481
2	1650/1710	2.225-6	3.000	3.750	CF 6-1-1731
2	1810	2.225-6	3.000	3.750	CF 6.5-1-481
2	1610	2.225-6	3.000	5.719	EY 5-4-4751X
2	1710	2.225-6	3.000	5.312	EY 6-4-3041X
2	1760	2.225-6	3.000	6.000	EY 6.3-4-171-1X
2	1760	2.225-6	3.000	6.000	EY 6.3-4-171X
2	1810	2.225-6	3.000	6.000	EY 6.5-4-2271X

8035					
1	1610	2.225-6	3.000	3.875	CF 5-1-2541
1	1650/1710	2.225-6	3.000	4.469	CF 6-1-1481
1	1810	2.225-6	3.000	3.750	CF 6.5-1-481
1	1610	2.225-6	3.000	5.719	EY 5-4-4751X
1	1710	2.225-6	3.000	5.312	EY 6-4-3041X
1	1760	2.225-6	3.000	6.000	EY 6.3-4-171-1X
1	1760	2.225-6	3.000	6.000	EY 6.3-4-171X
1	1810	2.225-6	3.000	6.000	EY 6.5-4-2271X
2	1610	2.225-6	3.000	3.875	CF 5-1-2541
2	1650/1710	2.225-6	3.000	4.469	CF 6-1-1481
2	1810	2.225-6	3.000	3.750	CF 6.5-1-481
2	1610	2.225-6	3.000	5.719	EY 5-4-4751X
2	1710	2.225-6	3.000	5.312	EY 6-4-3041X
2	1760	2.225-6	3.000	6.000	EY 6.3-4-171-1X
2	1760	2.225-6	3.000	6.000	EY 6.3-4-171X
2	1810	2.225-6	3.000	6.000	EY 6.5-4-2271X

8341					
1	1610	2.225-6	3.000	3.875	CF 5-1-2541
1	1650/1710	2.225-6	3.000	4.469	CF 6-1-1481
1	1650/1710	2.225-6	3.000	3.750	CF 6-1-1731
1	1810	2.225-6	3.000	3.750	CF 6.5-1-481
1	1610	2.225-6	3.000	5.719	EY 5-4-4751X
1	1710	2.225-6	3.000	5.312	EY 6-4-3041X
1	1760	2.225-6	3.000	6.000	EY 6.3-4-171-1X
1	1760	2.225-6	3.000	6.000	EY 6.3-4-171X
1	1810	2.225-6	3.000	6.000	EY 6.5-4-2271X
2	1610	2.225-6	3.000	3.875	CF 5-1-2541
2	1650/1710	2.225-6	3.000	4.469	CF 6-1-1481
2	1650/1710	2.225-6	3.000	3.750	CF 6-1-1731
2	1810	2.225-6	3.000	3.750	CF 6.5-1-481

Pos	Series	Spline Data	Hub Dia	* to End of Hub	End Fitting Part Number
-----	--------	-------------	---------	-----------------	-------------------------

8341 (Continued)					
2	SPL170	2.225-6	3.000	6.030	EY 170-4-1441-1
2	SPL250	2.225-6	3.000	6.250	EY 250-4-811-1
2	1610	2.225-6	3.000	5.719	EY 5-4-4751X
2	1710	2.225-6	3.000	5.312	EY 6-4-3041X
2	1760	2.225-6	3.000	6.000	EY 6.3-4-171-1X
2	1760	2.225-6	3.000	6.000	EY 6.3-4-171X
2	1810	2.225-6	3.000	6.000	EY 6.5-4-1971
2	1810	2.225-6	3.000	6.000	EY 6.5-4-1971-1
2	1810	2.225-6	3.000	6.000	EY 6.5-4-2271X
2	1810	2.225-6	3.000	6.000	EY 6.5-4-2831X

8345					
1	1610	2.225-6	3.000	3.875	CF 5-1-2541
1	1650/1710	2.225-6	3.000	4.469	CF 6-1-1481
1	1650/1710	2.225-6	3.000	3.750	CF 6-1-1731
1	1810	2.225-6	3.000	3.750	CF 6.5-1-481
1	1610	2.225-6	3.000	5.719	EY 5-4-4751X
1	1710	2.225-6	3.000	5.312	EY 6-4-3041X
1	1760	2.225-6	3.000	6.000	EY 6.3-4-171-1X
1	1760	2.225-6	3.000	6.000	EY 6.3-4-171X
1	1810	2.225-6	3.000	6.000	EY 6.5-4-2271X
2	1610	2.225-6	3.000	3.875	CF 5-1-2541
2	1650/1710	2.225-6	3.000	4.469	CF 6-1-1481
2	1650/1710	2.225-6	3.000	3.750	CF 6-1-1731
2	1810	2.225-6	3.000	3.750	CF 6.5-1-481
2	1610	2.225-6	3.000	5.719	EY 5-4-4751X
2	1710	2.225-6	3.000	5.312	EY 6-4-3041X
2	1760	2.225-6	3.000	6.000	EY 6.3-4-171-1X
2	1760	2.225-6	3.000	6.000	EY 6.3-4-171X

*C/L to End of Hub for EY (End Yoke); Flange Face to End of Hub for CF (Companion Flange)

■ Hub machined for speedometer gear



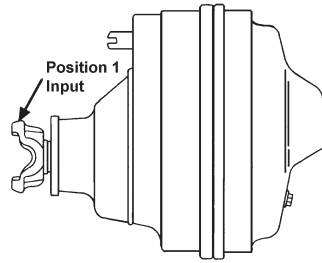

Pos	Series	Spline Data	Hub Dia	* to End of Hub	End Fitting Part Number
-----	--------	-------------	---------	-----------------	-------------------------

AXLE ALLIANCE CORP.

2					
1	SPL100	2.173-26	3.068	4.330	EY 100-4-1471-1X
4					
1	SPL100	2.143-41	3.000	4.310	EY 100-4-02875-1X
1	SPL100	2.143-41	3.000	4.310	EY 5002874
1	SPL100	2.143-41	3.000	4.310	EY 5002875
1	1610	2.143-41	3.000	4.680	EY 5002873
1	1710	2.143-41	3.000	5.030	EY 5002878
1	1710	2.143-41	3.000	5.030	EY 5002879
1	1710	2.143-41	3.000	5.380	EY 6-4-02877-1X High angle yoke

CLARK

FDS-12050					
1	1710	2.005-15	2.875	5.250	EY 6.5-4-2911
1	1710	2.005-15	2.875	5.375	EY 6-4-3001

1614, 1615, 1618, 1619, 1790-A, 1791-A, 1792, 1793, 1862					
1	1350/1410	1.750-10	2.625	3.125	CF 3-1-1521
1	1480/1550	1.750-10	2.625	2.875	CF 4-1-3101
1	1610	1.750-10	2.625	2.875	CF 5-1-811
1	1410	1.750-10	2.625	4.250	EY 3-4-2511-1 .250 deep spline chamfer
1	1480	1.750-10	2.625	4.469	EY 3-4-3121-1 .250 deep spline chamfer; C'bore depth is chamfered
1	1480	1.750-10	2.625	4.281	EY 3-4-5791-1X .250 deep spline chamfer; C'bore depth is chamfered
1	1550	1.750-10	2.625	4.672	EY 4-4-3581-1X .250 deep spline chamfer
1	1610	1.750-10	2.625	4.125	EY 5-4-781
1	1650	1.750-10	2.625	4.375	EY 5-4-4161X Chamfered Counterbore
1	1710	1.750-10	2.625	4.500	EY 6-4-5581X Chamfered Counterbore

1863					
1	1350/1410	1.750-10	2.625	3.125	CF 3-1-1521
1	1480/1550	1.750-10	2.625	2.875	CF 4-1-3101
1	1610	1.750-10	2.625	2.875	CF 5-1-811
1	1480	1.750-10	2.625	4.281	EY 3-4-5791-1X .250 deep spline chamfer; C'bore depth is chamfered
1	1550	1.750-10	2.625	4.672	EY 4-4-3581-1X .250 deep spline chamfer
1	1610	1.750-10	2.625	4.125	EY 5-4-781
1	1650	1.750-10	2.625	4.375	EY 5-4-4161X Chamfered Counterbore
1	1710	1.750-10	2.625	4.500	EY 6-4-5581X Chamfered Counterbore

Pos	Series	Spline Data	Hub Dia	* to End of Hub	End Fitting Part Number
-----	--------	-------------	---------	-----------------	-------------------------

1892, 1893, 1910, 1911, 2010, 2011, 2590, 2591, 2613, 2614, 2615, 2616, 2695, 2696, 6802, 6803					
1	1350/1410	1.750-10	2.625	3.125	CF 3-1-1521
1	1480/1550	1.750-10	2.625	2.875	CF 4-1-3101
1	1610	1.750-10	2.625	2.875	CF 5-1-811
1	1410	1.750-10	2.625	4.250	EY 3-4-2511-1 .250 deep spline chamfer
1	1480	1.750-10	2.625	4.469	EY 3-4-3121-1 .250 deep spline chamfer; C'bore depth is chamfered
1	1480	1.750-10	2.625	4.281	EY 3-4-5791-1X .250 deep spline chamfer; C'bore depth is chamfered
1	1550	1.750-10	2.625	4.672	EY 4-4-3581-1X .250 deep spline chamfer
1	1610	1.750-10	2.625	4.125	EY 5-4-781
1	1650	1.750-10	2.625	4.375	EY 5-4-4161X Chamfered Counterbore
1	1710	1.750-10	2.625	4.500	EY 6-4-5581X Chamfered Counterbore

7800					
1	1350/1410	1.750-10	2.625	3.125	CF 3-1-1521
1	1480/1550	1.750-10	2.625	2.875	CF 4-1-3101
1	1610	1.750-10	2.625	2.875	CF 5-1-811
1	1410	1.750-10	2.625	4.250	EY 3-4-2511-1 .250 deep spline chamfer
1	1480	1.750-10	2.625	4.469	EY 3-4-3121-1 .250 deep spline chamfer; C'bore depth is chamfered
1	1480	1.750-10	2.625	4.281	EY 3-4-5791-1X .250 deep spline chamfer; C'bore depth is chamfered
1	1610	1.750-10	2.625	4.125	EY 5-4-781
1	1650	1.750-10	2.625	4.375	EY 5-4-4161X Chamfered Counterbore
1	1710	1.750-10	2.625	4.500	EY 6-4-5581X Chamfered Counterbore

7801, 8802, 8803, 16500, 16501, 16600, 16601, 16802, 16803, 17800, 17801, 18802					
1	1350/1410	1.750-10	2.625	3.125	CF 3-1-1521
1	1480/1550	1.750-10	2.625	2.875	CF 4-1-3101
1	1610	1.750-10	2.625	2.875	CF 5-1-811
1	1410	1.750-10	2.625	4.250	EY 3-4-2511-1 .250 deep spline chamfer
1	1480	1.750-10	2.625	4.469	EY 3-4-3121-1 .250 deep spline chamfer; C'bore depth is chamfered
1	1480	1.750-10	2.625	4.281	EY 3-4-5791-1X .250 deep spline chamfer; C'bore depth is chamfered
1	1550	1.750-10	2.625	4.672	EY 4-4-3581-1X .250 deep spline chamfer
1	1610	1.750-10	2.625	4.125	EY 5-4-781
1	1650	1.750-10	2.625	4.375	EY 5-4-4161X Chamfered Counterbore
1	1710	1.750-10	2.625	4.500	EY 6-4-5581X Chamfered Counterbore

*C/L to End of Hub for EY (End Yoke); Flange Face to End of Hub for CF (Companion Flange)

■ Hub machined for speedometer gear



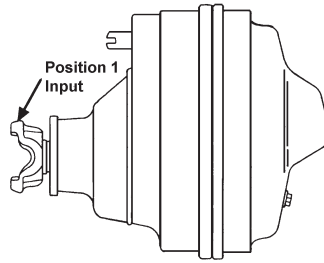

Pos	Series	Spline Data	Hub Dia	* to End of Hub	End Fitting Part Number
-----	--------	-------------	---------	-----------------	-------------------------

CLARK

18803

1	1350/1410	1.750-10	2.625	3.125	CF 3-1-1521
1	1480/1550	1.750-10	2.625	2.875	CF 4-1-3101
1	1610	1.750-10	2.625	2.875	CF 5-1-811
1	1410	1.750-10	2.625	4.250	EY 3-4-2511-1 .250 deep spline chamfer
1	1480	1.750-10	2.625	4.469	EY 3-4-3121-1 .250 deep spline chamfer; C'bore depth is chamfered
1	1480	1.750-10	2.625	4.281	EY 3-4-5791-1X .250 deep spline chamfer; C'bore depth is chamfered
1	1610	1.750-10	2.625	4.125	EY 5-4-781
1	1650	1.750-10	2.625	4.375	EY 5-4-4161X Chamfered Counterbore
1	1710	1.750-10	2.625	4.500	EY 6-4-5581X Chamfered Counterbore

19502, 19503, 20502, 20503

1	1350/1410	1.750-10	2.625	3.125	CF 3-1-1521
1	1480/1550	1.750-10	2.625	2.875	CF 4-1-3101
1	1610	1.750-10	2.625	2.875	CF 5-1-811
1	1410	1.750-10	2.625	4.250	EY 3-4-2511-1 .250 deep spline chamfer
1	1480	1.750-10	2.625	4.469	EY 3-4-3121-1 .250 deep spline chamfer; C'bore depth is chamfered
1	1480	1.750-10	2.625	4.281	EY 3-4-5791-1X .250 deep spline chamfer; C'bore depth is chamfered
1	1550	1.750-10	2.625	4.672	EY 4-4-3581-1X .250 deep spline chamfer
1	1610	1.750-10	2.625	4.125	EY 5-4-781
1	1650	1.750-10	2.625	4.375	EY 5-4-4161X Chamfered Counterbore
1	1710	1.750-10	2.625	4.500	EY 6-4-5581X Chamfered Counterbore

Pos	Series	Spline Data	Hub Dia	* to End of Hub	End Fitting Part Number
-----	--------	-------------	---------	-----------------	-------------------------

FABCO

FD-306

1	1710	1.750-10	2.750	2.938	CF 6-1-1761
1	1610	1.750-10	2.750	5.000	EY 5-4-3621
1	1610	1.750-10	2.750	6.000	EY 5-4-4441X High angle yoke
1	1610	1.750-10	2.750	5.406	EY 5-4-4481
1	1710	1.750-10	2.750	4.875	EY 6-4-2381
1	1710	1.750-10	2.750	6.250	EY 6-4-4091
1	1710	1.750-10	2.750	6.250	EY 6-4-4831X

FD-900

1	1480	1.500-10	2.250	4.406	EY 3-4-3241-1
1	1480	1.500-10	2.250	4.200	EY 3-4-6221-1X

FD-1600, FD-1610

1	1710	1.750-10	2.750	2.938	CF 6-1-1761
1	1610	1.750-10	2.750	5.000	EY 5-4-3621
1	1610	1.750-10	2.750	6.000	EY 5-4-4441X High angle yoke
1	1610	1.750-10	2.750	5.406	EY 5-4-4481
1	1710	1.750-10	2.750	4.875	EY 6-4-2381
1	1710	1.750-10	2.750	6.250	EY 6-4-4091
1	1710	1.750-10	2.750	6.250	EY 6-4-4831X

SDA-9

1	1350	1.750-10	2.375	4.000	EY 3-4-2351-1
1	1410	1.750-10	2.375	4.188	EY 3-4-1161-1
1	1550	1.750-10	2.375	4.000	EY 4-4-2041-1

SDA-12

1	1350	1.750-10	2.375	4.000	EY 3-4-2351-1
1	1410	1.750-10	2.375	4.188	EY 3-4-1161-1
1	1410	1.750-10	2.375	4.188	EY 3-4-1841-1
1	1480	1.750-10	2.375	4.219	EY 3-4-3571-1
1	1550	1.750-10	2.375	4.000	EY 4-4-2041-1

SDA-16

1	1350	1.750-10	2.625	3.125	CF 3-1-1521
1	1480/1550	1.750-10	2.625	2.875	CF 4-1-3101
1	1610	1.750-10	2.625	2.875	CF 5-1-811
1	1410	1.750-10	2.625	4.000	EY 3-4-5881-1X .250 deep spline chamfer
1	1480	1.750-10	2.625	4.281	EY 3-4-5791-1X .250 deep spline chamfer; C'bore depth is chamfered
1	1550	1.750-10	2.625	4.672	EY 4-4-3581-1X .250 deep spline chamfer
1	1610	1.750-10	2.625	4.750	EY 5-4-5111-1X
1	1610	1.750-10	2.625	4.750	EY 5-4-5111X
1	1710	1.750-10	2.625	5.250	EY 6-4-4301X Chamfered Counterbore

*C/L to End of Hub for EY (End Yoke); Flange Face to End of Hub for CF (Companion Flange)

■ Hub machined for speedometer gear



Pos	Series	Spline Data	Hub Dia	* to End of Hub	End Fitting Part Number
SDA-18					
1	1350	1.750-10	2.625	3.125	CF 3-1-1521
1	1480/1550	1.750-10	2.625	2.875	CF 4-1-3101
1	1610	1.750-10	2.625	2.875	CF 5-1-811
1	1410	1.750-10	2.625	4.000	EY 3-4-5881-1X
1	1480	1.750-10	2.625	4.281	EY 3-4-5791-1X <i>.250 deep spline chamfer</i>
1	1550	1.750-10	2.625	4.672	EY 4-4-3581-1X <i>.250 deep spline chamfer; C'bore depth is chamfered</i>
1	1610	1.962-10	2.625	5.312	EY 5-4-4471-1
1	1610	1.750-10	2.625	4.750	EY 5-4-5111-1X
1	1610	1.750-10	2.625	4.750	EY 5-4-5111X
1	1710	1.750-10	2.625	5.250	EY 6-4-4301X <i>Chamfered Counterbore</i>
1	1710	1.962-10	2.625	4.500	EY 6-4-4731-1X <i>Chamfered Counterbore</i>
1	1710	1.962-10	2.625	4.500	EY 6-4-4731X <i>Chamfered Counterbore</i>
1	1710	1.962-10	2.625	6.125	EY 6-4-4851-1X <i>Chamfered Counterbore; High angle yoke</i>
1	1710	1.962-10	2.625	6.125	EY 6-4-4851X <i>Chamfered Counterbore; High angle yoke</i>
1	1810	1.964-10	2.625	5.625	EY 6.5-4-2351X <i>Chamfered Counterbore</i>

SDA-21, SDA-23					
1	1710	2.149-16	2.938	5.500	EY 6-4-4171-1X
1	1710	2.149-16	2.938	5.500	EY 6-4-4171X
1	1810	2.149-16	2.938	5.812	EY 6.5-4-2401-1X
1	1810	2.149-16	2.938	5.812	EY 6.5-4-2401X

SDA-1200					
1	SPL140	1.790-34	2.625	4.870	EY 140-4-461-1
1	SPL140	1.790-34	2.625	4.870	EY 140-4-471-1X
1	1410	1.790-34	2.625	4.031	EY 3-4-10251-1
1	1480	1.790-34	2.625	4.281	EY 3-4-10261
1	1480	1.790-34	2.625	4.281	EY 3-4-10261-1
1	1550	1.790-34	2.625	4.275	EY 4-4-5551-1
1	1610	1.790-34	2.625	4.750	EY 5-4-7261
1	1610	1.790-34	2.625	4.750	EY 5-4-7261-1
1	1710	1.790-34	2.625	5.438	EY 6-4-7571-1

SDA-1400					
1	1480	1.790-34	2.625	4.281	EY 3-4-10261
1	1480	1.790-34	2.625	4.281	EY 3-4-10261-1
1	1550	1.790-34	2.625	4.275	EY 4-4-5551-1
1	1610	1.790-34	2.625	4.750	EY 5-4-7261
1	1610	1.790-34	2.625	4.750	EY 5-4-7261-1
1	1710	1.790-34	2.625	5.438	EY 6-4-7571-1

SDA-1600					
1	1410	1.790-34	2.625	4.031	EY 3-4-10251-1
1	1480	1.790-34	2.625	4.281	EY 3-4-10261
1	1480	1.790-34	2.625	4.281	EY 3-4-10261-1
1	1550	1.790-34	2.625	4.275	EY 4-4-5551-1
1	1610	1.790-34	2.625	4.750	EY 5-4-7261
1	1610	1.790-34	2.625	4.750	EY 5-4-7261-1
1	1710	1.790-34	2.625	5.438	EY 6-4-7571-1

SDA-1800					
1	SPL140	2.024-39	2.625	5.030	EY 140-4-551-1 <i>Counterbore at hub end.</i>
1	SPL140	2.024-39	2.625	5.030	EY 140-4-561-1X <i>Counterbore at hub end.</i>

Pos	Series	Spline Data	Hub Dia	* to End of Hub	End Fitting Part Number
SDA-1800 (Continued)					
1	SPL170	2.024-39	2.625	4.938	EY 170-4-151-1
1	SPL170	2.024-39	2.625	4.938	EY 170-4-161-1X
1	1610	2.024-39	2.625	5.312	EY 5-4-7971
1	1610	2.024-39	2.625	5.312	EY 5-4-7971-1
1	1610	2.024-39	2.625	6.000	EY 5-4-7991 <i>High angle yoke</i>
1	1610	2.024-39	2.625	5.312	EY 5-4-8411-1X
1	1610	2.024-39	2.625	5.312	EY 5-4-8411X
1	1610	2.024-39	2.625	6.000	EY 5-4-8421X <i>High angle yoke</i>
1	1710	2.024-39	2.625	6.125	EY 6-4-7981 <i>High angle yoke</i>
1	1710	2.024-39	2.625	6.125	EY 6-4-7981-1 <i>High angle yoke</i>
1	1710	2.024-39	2.625	5.250	EY 6-4-7991
1	1710	2.024-39	2.625	5.250	EY 6-4-7991-1
1	1710	2.024-39	2.625	5.250	EY 6-4-8531-1X
1	1710	2.024-39	2.625	5.250	EY 6-4-8531X
1	1710	2.024-39	2.625	6.125	EY 6-4-8541-1X <i>High angle yoke</i>
1	1710	2.024-39	2.625	6.125	EY 6-4-8541X <i>High angle yoke</i>

SDA-2100					
1	1610	2.024-39	2.625	5.312	EY 5-4-8411-1X
1	1610	2.024-39	2.625	5.312	EY 5-4-8411X
1	1610	2.024-39	2.625	6.000	EY 5-4-8421X <i>High angle yoke</i>
1	1710	2.024-39	2.625	5.250	EY 6-4-8531-1X
1	1710	2.024-39	2.625	5.250	EY 6-4-8531X
1	1710	2.024-39	2.625	6.125	EY 6-4-8541-1X <i>High angle yoke</i>
1	1710	2.024-39	2.625	6.125	EY 6-4-8541X <i>High angle yoke</i>

SDA-2300					
1	1610	2.143-41	2.938	5.250	EY 5-4-7271-1
1	1610	2.143-41	2.938	6.000	EY 5-4-7561
1	1610	2.143-41	2.938	6.000	EY 5-4-7561-1
1	1610	2.143-41	2.938	5.250	EY 5-4-9111-1X
1	1610	2.143-41	2.938	6.000	EY 5-4-9121-1X
1	1610	2.143-41	2.938	6.000	EY 5-4-9121X
1	1710	2.143-41	2.938	5.190	EY 6-4-7311
1	1710	2.143-41	2.938	5.190	EY 6-4-7311-1
1	1710	2.143-41	2.938	6.125	EY 6-4-7551 <i>High angle yoke</i>
1	1710	2.143-41	2.938	6.125	EY 6-4-7551-1 <i>High angle yoke</i>
1	1710	2.143-41	2.938	5.190	EY 6-4-9171-1X
1	1710	2.143-41	2.938	5.190	EY 6-4-9171X
1	1710	2.143-41	2.938	6.125	EY 6-4-9181-1X <i>High angle yoke</i>
1	1710	2.143-41	2.938	6.125	EY 6-4-9181X <i>High angle yoke</i>
1	1760	2.143-41	2.938	5.250	EY 6.3-4-1061
1	1760	2.143-41	2.938	5.250	EY 6.3-4-1061-1
1	1760	2.143-41	2.938	5.250	EY 6.3-4-1631-1X
1	1810	2.143-41	2.938	5.250	EY 6.5-4-3681
1	1810	2.143-41	2.938	5.250	EY 6.5-4-3681-1
1	1810	2.143-41	2.938	5.250	EY 6.5-4-4601-1X
1	1810	2.143-41	2.938	5.250	EY 6.5-4-4601X

*C/L to End of Hub for EY (End Yoke); Flange Face to End of Hub for CF (Companion Flange)

■ Hub machined for speedometer gear



Important: See Safety Information in General Information Section (J300P-GI)

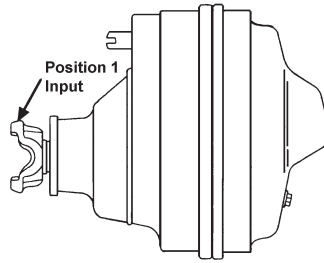

Pos	Series	Spline Data	Hub Dia	* to End of Hub	End Fitting Part Number
-----	--------	-------------	---------	-----------------	-------------------------

RA-25					
1	1350	1.750-10	2.375	4.000	EY 3-4-2351-1
1	1410	1.750-10	2.375	4.188	EY 3-4-1841-1
1	1480	1.750-10	2.375	4.219	EY 3-4-3571-1
1	1550	1.750-10	2.375	4.000	EY 4-4-2041-1
1	1550	1.790-34	2.375	4.000	EY 4-4-6961-1X
1	1610	1.750-10	2.375	4.188	EY 5-4-1481
1	1610	1.750-10	2.375	4.688	EY 5-4-1481-1

RA-29					
1	1350	1.750-10	2.375	4.000	EY 3-4-2351-1
1	1410	1.750-10	2.375	4.188	EY 3-4-1841-1
1	1480	1.790-34	2.375	4.219	EY 3-4-12101-1X
1	1480	1.750-10	2.375	4.219	EY 3-4-3571-1
1	1550	1.750-10	2.375	4.000	EY 4-4-2041-1
1	1550	1.790-34	2.375	4.000	EY 4-4-6961-1X
1	1610	1.750-10	2.375	4.188	EY 5-4-1481
1	1610	1.750-10	2.375	4.688	EY 5-4-1481-1

RA-30					
1	1350	1.750-10	2.375	4.000	EY 3-4-2351-1
1	1410	1.750-10	2.375	4.188	EY 3-4-1841-1
1	1480	1.750-10	2.375	4.219	EY 3-4-3571-1
1	1550	1.750-10	2.375	4.000	EY 4-4-2041-1
1	1550	1.790-34	2.375	4.000	EY 4-4-6961-1X
1	1610	1.750-10	2.375	4.188	EY 5-4-1481
1	1610	1.750-10	2.375	4.688	EY 5-4-1481-1

RA-31, RA-32, RA-33, RA-34					
1	1480	1.998-38	3.000	4.281	EY 3-4-12121-1X
1	1550	1.998-38	3.000	4.500	EY 4-4-6981-1X
1	1610	1.998-38	3.000	4.844	EY 5-4-5861X
1	1610	1.998-38	3.000	4.844	EY 5-4-8591-1X
1	1710	1.998-38	3.000	4.840	EY 6-4-9951-1
1	1710	1.998-38	3.000	4.840	EY 6-4-9961-1X

RA-36					
1	1550	2.114-32	3.000	4.312	EY 4-4-7001-1X
1	1610	2.114-32	3.000	5.375	EY 5-4-7221X
1	1610	2.114-32	3.000	5.375	EY 5-4-8611-1X
1	1710	2.114-32	3.000	4.562	EY 6-4-5811
1	1710	2.114-32	3.000	6.250	EY 6-4-7171X <i>High angle yoke</i>
1	1710	2.114-32	3.000	4.562	EY 6-4-7221X
1	1710	2.114-32	3.000	4.562	EY 6-4-8681-1X
1	1760	2.114-32	3.000	5.000	EY 6.3-4-1511-1
1	1760	2.114-32	3.000	5.000	EY 6.3-4-1521-1X
1	1810	2.114-32	3.000	5.000	EY 6.5-4-4451-1
1	1810	2.114-32	3.000	5.000	EY 6.5-4-4461-1X

RA-39					
1	1350	1.750-10	2.375	4.000	EY 3-4-2351-1
1	1410	1.750-10	2.375	4.188	EY 3-4-1841-1

Pos	Series	Spline Data	Hub Dia	* to End of Hub	End Fitting Part Number
-----	--------	-------------	---------	-----------------	-------------------------

RA-39 (Continued)					
1	1480	1.790-34	2.375	4.219	EY 3-4-12101-1X
1	1480	1.750-10	2.375	4.219	EY 3-4-3571-1
1	1550	1.750-10	2.375	4.000	EY 4-4-2041-1
1	1550	1.790-34	2.375	4.000	EY 4-4-6961-1X
1	1610	1.750-10	2.375	4.188	EY 5-4-1481
1	1610	1.750-10	2.375	4.688	EY 5-4-1481-1

RA-42, RA-44, RA-47					
1	1550	2.114-32	3.000	4.312	EY 4-4-7001-1X
1	1610	2.114-32	3.000	5.375	EY 5-4-5751
1	1610	2.114-32	3.000	5.375	EY 5-4-7221X
1	1610	2.114-32	3.000	5.375	EY 5-4-8611-1X
1	1710	2.114-32	3.000	4.562	EY 6-4-5811
1	1710	2.114-32	3.000	6.250	EY 6-4-7171X <i>High angle yoke</i>
1	1710	2.114-32	3.000	4.562	EY 6-4-7221X
1	1710	2.114-32	3.000	4.562	EY 6-4-8681-1X
1	1760	2.114-32	3.000	5.000	EY 6.3-4-1511-1
1	1760	2.114-32	3.000	5.000	EY 6.3-4-1521-1X
1	1810	2.114-32	3.000	5.000	EY 6.5-4-4451-1
1	1810	2.114-32	3.000	5.000	EY 6.5-4-4461-1X

RA-48					
1	1550	2.114-32	3.000	4.312	EY 4-4-7001-1X
1	1610	2.114-32	3.000	5.375	EY 5-4-5751
1	1610	2.114-32	3.000	5.375	EY 5-4-7221X
1	1610	2.114-32	3.000	5.375	EY 5-4-8611-1X
1	1710	2.114-32	3.000	6.250	EY 6-4-7171X <i>High angle yoke</i>
1	1710	2.114-32	3.000	4.562	EY 6-4-7221X
1	1710	2.114-32	3.000	4.562	EY 6-4-8681-1X

RA-54					
1	1610	1.962-10	3.000	5.375	EY 5-4-4541
1	1710	2.250-10	3.000	5.250	EY 6-4-2511
1	1710	1.964-10	3.000	4.562	EY 6-4-3291

RA-57					
1	1550	2.364-36	3.000	5.078	EY 4-4-7111-1X
1	1610	1.962-10	3.000	5.375	EY 5-4-4541
1	1610	2.364-36	3.000	5.156	EY 5-4-7201X
1	1610	2.364-36	3.000	5.156	EY 5-4-8631-1X
1	1710	1.964-10	3.000	4.562	EY 6-4-3291
1	1710	2.364-36	3.000	5.438	EY 6-4-5711
1	1710	2.364-36	3.000	5.438	EY 6-4-7191X
1	1710	2.364-36	3.000	5.438	EY 6-4-8701-1X
1	1760	2.364-36	3.000	5.438	EY 6.3-4-1021X
1	1760	2.364-36	3.000	5.438	EY 6.3-4-1531-1
1	1760	2.364-36	3.000	5.438	EY 6.3-4-1541-1X
1	1810	2.364-36	3.000	5.438	EY 6.5-4-3161
1	1810	2.364-36	3.000	5.438	EY 6.5-4-3651X
1	1810	2.364-36	3.000	5.438	EY 6.5-4-4421-1X

*C/L to End of Hub for EY (End Yoke); Flange Face to End of Hub for CF (Companion Flange)

■ Hub machined for speedometer gear



Pos	Series	Spline Data	Hub Dia	* to End of Hub	End Fitting Part Number
RA-130, RA-131, RA-132					
1	1480	1.998-38	3.000	4.281	EY 3-4-12121-1X
1	1550	1.998-38	3.000	4.500	EY 4-4-6981-1X
1	1610	1.998-38	3.000	4.844	EY 5-4-5861X
1	1610	1.998-38	3.000	4.844	EY 5-4-8591-1X
1	1710	1.998-38	3.000	4.840	EY 6-4-9951-1
1	1710	1.998-38	3.000	4.840	EY 6-4-9961-1X
RA-133					
1	1480	1.998-38	3.000	4.281	EY 3-4-12121-1X
1	1550	1.998-38	3.000	4.500	EY 4-4-6981-1X
1	1610	1.998-38	3.000	4.844	EY 5-4-5861X
1	1610	1.998-38	3.000	4.844	EY 5-4-8591-1X
1	1710	1.998-38	3.000	4.840	EY 6-4-9951-1
RA-186					
1	1550	1.750-10	2.625	4.281	EY 4-4-2091-1
1	1610	1.750-10	2.625	5.344	EY 5-4-4461
1	1610	1.750-10	2.625	5.344	EY 5-4-4461-1
1	1710	1.750-10	2.625	4.500	EY 6-4-5581-1X
1	1710	1.750-10	2.625	4.500	EY 6-4-5581X <i>Chamfered Counterbore</i>
RA-189					
1	1350	1.750-10	2.375	4.000	EY 3-4-2351-1
1	1410	1.750-10	2.375	4.188	EY 3-4-1841-1
1	1480	1.750-10	2.375	4.219	EY 3-4-3571-1
1	1550	1.750-10	2.375	4.000	EY 4-4-2041-1
1	1610	1.750-10	2.375	4.188	EY 5-4-1481
1	1610	1.750-10	2.375	4.688	EY 5-4-1481-1
RA-192					
1	1550	1.750-10	2.625	4.281	EY 4-4-2091-1
1	1610	1.750-10	2.625	5.344	EY 5-4-4461
1	1710	1.750-10	2.625	4.500	EY 6-4-5581-1X
1	1710	1.750-10	2.625	4.500	EY 6-4-5581X <i>Chamfered Counterbore</i>
RA-197					
1	1610	1.962-10	2.625	5.312	EY 5-4-4471-1
1	1810	1.964-10	2.625	5.625	EY 6.5-4-2351X <i>Chamfered Counterbore</i>
RA-286					
1	1550	1.750-10	2.625	4.281	EY 4-4-2091-1
1	1610	1.750-10	2.625	5.344	EY 5-4-4461
1	1610	1.750-10	2.625	5.344	EY 5-4-4461-1
1	1710	1.750-10	2.625	4.500	EY 6-4-5581-1X
1	1710	1.750-10	2.625	4.500	EY 6-4-5581X <i>Chamfered Counterbore</i>
014ADB, 014ADC, 014ADD					
1	1550	2.114-32	3.000	4.312	EY 4-4-7001-1X
1	1610	2.114-32	3.000	5.375	EY 5-4-5751
1	1610	2.114-32	3.000	5.375	EY 5-4-7221X
1	1610	2.114-32	3.000	5.375	EY 5-4-8611-1X
1	1710	2.114-32	3.000	4.562	EY 6-4-5811
1	1710	2.114-32	3.000	6.250	EY 6-4-7171X <i>High angle yoke</i>
1	1710	2.114-32	3.000	4.562	EY 6-4-7221X
1	1710	2.114-32	3.000	4.562	EY 6-4-8681-1X
1	1760	2.114-32	3.000	5.000	EY 6.3-4-1521-1X
1	1810	2.114-32	3.000	5.000	EY 6.5-4-4451-1
1	1810	2.114-32	3.000	5.000	EY 6.5-4-4461-1X

Pos	Series	Spline Data	Hub Dia	* to End of Hub	End Fitting Part Number
-----	--------	-------------	---------	-----------------	-------------------------

*C/L to End of Hub for EY (End Yoke); Flange Face to End of Hub for CF (Companion Flange)

■ Hub machined for speedometer gear



Important: See Safety Information in General Information Section (J300P-GI)

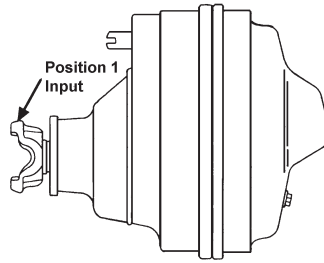

Pos	Series	Spline Data	Hub Dia	* to End of Hub	End Fitting Part Number
-----	--------	-------------	---------	-----------------	-------------------------

MACK

CRD93A

1	SPL170	2.374-46	3.500	5.880	EY 170-4-1211-1
1	SPL170	2.374-46	3.500	5.880	EY 170-4-1221-1X
1	SPL170	2.374-46	3.500	6.688	EY 170-4-1281-1 <i>High angle yoke</i>
1	SPL170	2.374-46	3.500	6.688	EY 170-4-1291-1X <i>High angle yoke</i>
1	SPL250	2.374-46	3.500	6.140	EY 250-4-641-1
1	SPL250	2.374-46	3.500	6.140	EY 250-4-651-1X
1	1710	2.374-46	3.500	5.156	EY 6-4-5841
1	1710	2.374-46	3.500	5.156	EY 6-4-5841-1
1	1710	2.374-46	3.500	5.156	EY 6-4-8341-1X
1	1710	2.374-46	3.500	5.156	EY 6-4-8341X
1	1760	2.374-46	3.500	5.375	EY 6.3-4-1391-1X
1	1760	2.374-46	3.500	5.375	EY 6.3-4-1391X
1	1760	2.374-46	3.500	5.375	EY 6.3-4-391
1	1760	2.374-46	3.500	5.375	EY 6.3-4-391-1
1	1810	2.374-46	3.500	5.406	EY 6.5-4-3251
1	1810	2.374-46	3.500	5.406	EY 6.5-4-3251-1
1	1810	2.374-46	3.500	5.406	EY 6.5-4-4271-1X
1	1810	2.374-46	3.500	5.406	EY 6.5-4-4271X

CRD118

1	SPL250	2.250-10	3.125	5.234	EY 250-4-681-1
1	SPL250	2.250-10	3.125	5.234	EY 250-4-691-1X
1	1810	2.250-10	3.125	5.375	EY 6.5-4-2141
1	1810	2.250-10	3.125	5.375	EY 6.5-4-2141-1
1	1810	2.250-10	3.125	5.375	EY 6.5-4-4221-1X

CRD150, CRD151

1	SPL170	2.750-43	3.750	5.929	EY 170-4-1931-1X
1	SPL250	2.750-43	3.750	5.500	EY 250-4-1061-1X
1	1710	2.750-43	3.750	5.929	EY 6-4-10351-1X
1	1710	2.750-43	3.750	5.929	EY 6-4-10351X
1	1760	2.753-43	3.750	4.870	EY 6.3-4-1891-1X
1	1760	2.753-43	3.750	4.870	EY 6.3-4-1891X
1	1810	2.750-43	3.750	5.406	EY 6.5-4-5131-1X
1	1810	2.750-43	3.750	5.406	EY 6.5-4-5131X

CRD201, CRD203

1	SPL170	2.374-46	3.500	5.880	EY 170-4-1211-1
1	SPL170	2.374-46	3.500	5.880	EY 170-4-1221-1X
1	SPL170	2.374-46	3.500	6.688	EY 170-4-1281-1 <i>High angle yoke</i>
1	SPL170	2.374-46	3.500	6.688	EY 170-4-1291-1X <i>High angle yoke</i>
1	SPL250	2.374-46	3.500	6.140	EY 250-4-641-1
1	SPL250	2.374-46	3.500	6.140	EY 250-4-651-1X
1	1710	2.374-46	3.500	5.156	EY 6-4-5841
1	1710	2.374-46	3.500	5.156	EY 6-4-5841-1

Pos	Series	Spline Data	Hub Dia	* to End of Hub	End Fitting Part Number
-----	--------	-------------	---------	-----------------	-------------------------

CRD201, CRD203 (Continued)

1	1710	2.374-46	3.500	5.156	EY 6-4-8341-1X
1	1710	2.374-46	3.500	5.156	EY 6-4-8341X
1	1760	2.374-46	3.500	5.375	EY 6.3-4-1391-1X
1	1760	2.374-46	3.500	5.375	EY 6.3-4-1391X
1	1760	2.374-46	3.500	5.375	EY 6.3-4-391
1	1760	2.374-46	3.500	5.375	EY 6.3-4-391-1
1	1810	2.374-46	3.500	5.406	EY 6.5-4-3251
1	1810	2.374-46	3.500	5.406	EY 6.5-4-3251-1
1	1810	2.374-46	3.500	5.406	EY 6.5-4-4271-1X
1	1810	2.374-46	3.500	5.406	EY 6.5-4-4271X

OSHKOSH

TAK-4

1	SPL170	1.998-38	3.000	4.898	EY 170-4-1961-1X
---	--------	----------	-------	-------	------------------

MERITOR/ROCKWELL

D-460F

1	1710	2.000-10	3.250	5.625	EY 6-4-2001
---	------	----------	-------	-------	-------------

E-155

1	1480	1.500-10	2.250	4.406	EY 3-4-3241-1
1	1480	1.500-10	2.250	4.200	EY 3-4-3781-1

E-245

1	1410	1.500-10	2.250	3.750	EY 3-4-1911-1
---	------	----------	-------	-------	---------------

F-34, F-106, F-140, F-145

1	1480	1.500-10	2.250	4.406	EY 3-4-3241-1
1	1480	1.500-10	2.250	4.200	EY 3-4-3781-1

F-223, F-235

1	1610	1.750-10	2.750	5.000	EY 5-4-3621
1	1610	1.750-10	2.750	6.000	EY 5-4-4441X <i>High angle yoke</i>
1	1710	1.750-10	2.750	4.875	EY 6-4-2381
1	1710	2.350-16	3.312	4.938	EY 6-4-4601 <i>Coupling shaft yoke</i>
1	1710	1.750-10	2.750	6.250	EY 6-4-4831X

F-245, F-345

1	1410	1.500-10	2.250	3.750	EY 3-4-1911-1
---	------	----------	-------	-------	---------------

F-409CW, F-429CN

1	1710	1.960-10	2.938	4.500	EY 6-4-2061
---	------	----------	-------	-------	-------------

F-3100

1	1480/1550	2.000-10	2.938	3.625	CF 4-1-2361
1	1610	2.000-10	2.938	3.625	CF 5-1-3161
1	1610	2.000-10	2.938	5.000	EY 5-4-1521
1	1710	2.000-10	2.938	5.625	EY 6-4-2191

F-3110

1	1710	1.960-10	2.938	4.500	EY 6-4-2061
---	------	----------	-------	-------	-------------

*C/L to End of Hub for EY (End Yoke); Flange Face to End of Hub for CF (Companion Flange)

■ Hub machined for speedometer gear



Pos	Series	Spline Data	Hub Dia	* to End of Hub	End Fitting Part Number
F-3200					
1	1480/1550	2.000-10	2.938	3.625	CF 4-1-2361
1	1610	2.000-10	2.938	3.625	CF 5-1-3161
1	1610	2.000-10	2.938	5.000	EY 5-4-1521
1	1710	2.000-10	2.938	5.625	EY 6-4-2191
FDS-75, FDS-90					
1	1480	1.500-10	2.250	4.406	EY 3-4-3241-1
1	1480	1.500-10	2.250	4.200	EY 3-4-3781-1
FDS-1600					
1	1350/1410	1.625-10	2.375	3.000	CF 3-1-3531
1	1480/1550	1.625-10	2.375	2.750	CF 4-1-2751
1	1410	1.625-10	2.375	3.938	EY 3-4-3491-1
1	1410	1.625-10	2.375	4.188	EY 3-4-5921-1X
1	1480	1.625-10	2.375	4.312	EY 3-4-3771
1	1610	1.625-10	2.375	4.125	EY 5-4-2401
FDS-1800, FDS-2100					
1	1610	2.024-39	2.750	5.125	EY 5-4-6951X
1	1610	2.024-39	2.750	5.938	EY 5-4-6961X <i>High angle yoke</i>
1	1710	2.024-39	2.750	6.500	EY 6-4-6871X
1	1710	2.024-39	2.750	4.812	EY 6-4-6941X
1	1710	2.024-39	2.750	5.250	EY 6-4-6951-1X
1	1710	2.024-39	2.750	5.250	EY 6-4-6951X
1	1810	2.024-39	2.750	5.625	EY 6.5-4-3571-1X
1	1810	2.024-39	2.750	5.531	EY 6.5-4-3571X
FDS-750					
1	1410	1.500-10	2.250	3.750	EY 3-4-1911-1
G-100					
1	1710	2.024-39	3.000	5.156	EY 6-4-7621-1
1	1710	2.024-39	3.000	5.156	EY 6-4-7641-1X
G-160, G-340, G-360, H-140, H-150, H-160, H-170					
1	1350/1410	1.625-10	2.375	3.000	CF 3-1-3531
1	1480/1550	1.625-10	2.375	2.750	CF 4-1-2751
1	1410	1.625-10	2.375	3.938	EY 3-4-3491-1
1	1410	1.625-10	2.375	4.188	EY 3-4-5921-1X
1	1610	1.625-10	2.375	4.125	EY 5-4-2401
H-172					
1	1410	1.774-34	2.500	4.188	EY 3-4-8061X
1	1480	1.774-34	2.500	4.469	EY 3-4-8051-1X
1	1550	1.774-34	2.500	4.700	EY 4-4-4101-1
1	1550	1.774-34	2.500	4.700	EY 4-4-4101-2 <i>Attaching hardware by OEM</i>
1	1550	1.774-34	2.500	4.700	EY 4-4-4111-1X
1	1610	1.774-34	2.500	6.062	EY 5-4-4901X <i>High angle yoke</i>
1	1610	1.774-34	2.500	5.438	EY 5-4-5081X
1	1610	1.774-34	2.500	4.875	EY 5-4-5571-1
1	1610	1.774-34	2.500	4.875	EY 5-4-5621-1X
1	1710	1.774-34	2.500	5.969	EY 6-4-5111X <i>High angle yoke</i>
1	1710	1.774-34	2.500	4.875	EY 6-4-5131-1X
1	1710	1.774-34	2.500	4.875	EY 6-4-5131X
H-240, H-340, H-350, H-360, H-370					
1	1350/1410	1.625-10	2.375	3.000	CF 3-1-3531
1	1480/1550	1.625-10	2.375	2.750	CF 4-1-2751
1	1410	1.625-10	2.375	3.938	EY 3-4-3491-1
1	1410	1.625-10	2.375	4.188	EY 3-4-5921-1X
1	1610	1.625-10	2.375	4.125	EY 5-4-2401

Pos	Series	Spline Data	Hub Dia	* to End of Hub	End Fitting Part Number
L-140, L-160					
1	1650/1710	1.750-10	2.750	2.938	CF 6-1-1761
1	1610	1.750-10	2.750	5.000	EY 5-4-3621
1	1610	1.750-10	2.750	6.000	EY 5-4-4441X <i>High angle yoke</i>
1	1610	1.750-10	2.750	5.406	EY 5-4-4481
1	1710	1.750-10	2.750	4.875	EY 6-4-2381
1	1710	2.350-16	3.312	4.938	EY 6-4-4601 <i>Coupling shaft yoke</i>
1	1710	1.750-10	2.750	6.250	EY 6-4-4831X
L-172					
1	1410	1.774-34	2.500	4.188	EY 3-4-8061X
1	1480	1.774-34	2.500	4.469	EY 3-4-8051-1X
1	1550	1.774-34	2.500	4.700	EY 4-4-4101-1
1	1550	1.774-34	2.500	4.700	EY 4-4-4101-2 <i>Attaching hardware by OEM</i>
1	1550	1.774-34	2.500	4.700	EY 4-4-4111-1X
1	1610	1.774-34	2.500	6.062	EY 5-4-4901X <i>High angle yoke</i>
1	1610	1.774-34	2.500	5.438	EY 5-4-5081X
1	1610	1.774-34	2.500	4.875	EY 5-4-5571-1
1	1610	1.774-34	2.500	4.875	EY 5-4-5621-1X
1	1710	1.774-34	2.500	5.969	EY 6-4-5111X <i>High angle yoke</i>
1	1710	1.774-34	2.500	4.875	EY 6-4-5131-1X
1	1710	1.774-34	2.500	4.875	EY 6-4-5131X
L-240, L-340, L-350, L-360, L-370					
1	1650/1710	1.750-10	2.750	2.938	CF 6-1-1761
1	1610	1.750-10	2.750	5.000	EY 5-4-3621
1	1610	1.750-10	2.750	6.000	EY 5-4-4441X <i>High angle yoke</i>
1	1610	1.750-10	2.750	5.406	EY 5-4-4481
1	1710	1.750-10	2.750	4.875	EY 6-4-2381
1	1710	2.350-16	3.312	4.938	EY 6-4-4601 <i>Coupling shaft yoke</i>
1	1710	1.750-10	2.750	6.250	EY 6-4-4831X
L-600					
1	1410	1.774-34	2.500	4.188	EY 3-4-8061X
1	1480	1.774-34	2.500	4.469	EY 3-4-8051-1X
1	1550	1.774-34	2.500	4.700	EY 4-4-4101-1
1	1550	1.774-34	2.500	4.700	EY 4-4-4101-2 <i>Attaching hardware by OEM</i>
1	1550	1.774-34	2.500	4.700	EY 4-4-4111-1X
1	1610	1.774-34	2.500	6.062	EY 5-4-4901X <i>High angle yoke</i>
1	1610	1.774-34	2.500	5.438	EY 5-4-5081X
1	1610	1.774-34	2.500	4.875	EY 5-4-5571-1
1	1610	1.774-34	2.500	4.875	EY 5-4-5621-1X
1	1710	1.774-34	2.500	5.969	EY 6-4-5111X <i>High angle yoke</i>
1	1710	1.774-34	2.500	4.875	EY 6-4-5131-1X
1	1710	1.774-34	2.500	4.875	EY 6-4-5131X
LT-300, LT-340					
1	1480	1.875-10	2.750	4.406	EY 3-4-6671-1X
1	1550	1.875-10	2.750	4.406	EY 4-4-1941
1	1610	1.875-10	2.750	5.000	EY 5-4-2501

*C/L to End of Hub for EY (End Yoke); Flange Face to End of Hub for CF (Companion Flange)

■ Hub machined for speedometer gear



Important: See Safety Information in General Information Section (J300P-GI)

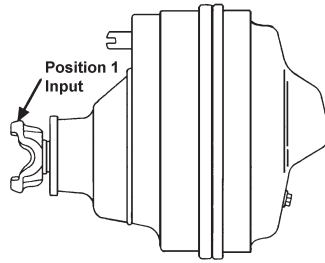

Pos	Series	Spline Data	Hub Dia	* to End of Hub	End Fitting Part Number
M-172					
1	1410	1.774-34	2.500	4.188	EY 3-4-8061X
1	1550	1.774-34	2.500	4.700	EY 4-4-4101-1
1	1550	1.774-34	2.500	4.700	EY 4-4-4101-2
<i>Attaching hardware by OEM</i>					
1	1550	1.774-34	2.500	4.700	EY 4-4-4111-1X
1	1610	1.774-34	2.500	6.062	EY 5-4-4901X <i>High angle yoke</i>
1	1610	1.774-34	2.500	5.438	EY 5-4-5081X
1	1610	1.774-34	2.500	4.875	EY 5-4-5571-1
1	1610	1.774-34	2.500	4.875	EY 5-4-5621-1X
1	1710	1.774-34	2.500	5.969	EY 6-4-5111X <i>High angle yoke</i>
1	1710	1.774-34	2.500	4.875	EY 6-4-5131-1X
1	1710	1.774-34	2.500	4.875	EY 6-4-5131X
M-175					
1	1480	1.774-34	2.500	4.469	EY 3-4-8051-1X
PR-200, PR-223					
1	1480	1.875-10	2.750	4.406	EY 3-4-6671-1X
1	1550	1.875-10	2.750	4.406	EY 4-4-1941
1	1610	1.875-10	2.750	5.000	EY 5-4-2501
PR-250					
1	1810	2.250-10	3.000	5.844	EY 6.5-4-1911
PR-300, PR-400, PR-500					
1	1480/1550	1.960-10	2.750	3.375	CF 4-1-2661
1	1710	1.960-10	2.750	3.312	CF 6-1-1461
1	1610	1.960-10	2.750	5.125	EY 5-4-5281X
1	1710	1.960-10	2.750	5.250	EY 6-4-4361X
1	1710	1.960-10	2.750	6.500	EY 6-4-4481X <i>High angle yoke</i>
1	1810	2.250-10	3.000	5.844	EY 6.5-4-1911
PS-200					
1	1480	1.875-10	2.750	4.406	EY 3-4-6671-1X
1	1550	1.875-10	2.750	4.406	EY 4-4-1941
1	1610	1.875-10	2.750	5.000	EY 5-4-2501
PS-300					
1	1480/1550	1.960-10	2.750	3.375	CF 4-1-2661
1	1710	1.960-10	2.750	3.312	CF 6-1-1461
1	1610	1.960-10	2.750	5.125	EY 5-4-5281X
1	1710	1.960-10	2.750	5.250	EY 6-4-4361X
1	1710	1.960-10	2.750	6.500	EY 6-4-4481X <i>High angle yoke</i>
1	1810	2.250-10	3.000	5.844	EY 6.5-4-1911
PS-400, PS-500					
1	1810	2.250-10	3.000	5.844	EY 6.5-4-1911
Q-100					
1	1480	1.875-10	2.750	4.406	EY 3-4-6671-1X
1	1550	1.875-10	2.750	4.406	EY 4-4-1941

Pos	Series	Spline Data	Hub Dia	* to End of Hub	End Fitting Part Number
Q-100 (Continued)					
1	1610	1.875-10	2.750	5.000	EY 5-4-2501
1	1610	2.024-39	3.000	5.531	EY 5-4-6281X
1	1610	2.024-39	3.000	6.219	EY 5-4-6291X <i>High angle yoke</i>
1	1610	2.024-39	3.000	4.875	EY 5-4-6431-1X
1	1610	2.024-39	3.000	4.875	EY 5-4-6431X
1	1610	2.024-39	3.000	4.875	EY 5-4-6441-1X
1	1710	2.024-39	3.000	6.250	EY 6-4-6391-1X <i>High angle yoke</i>
1	1710	2.024-39	3.000	6.250	EY 6-4-6391X <i>High angle yoke</i>
1	1710	2.024-39	3.000	5.156	EY 6-4-6401-1
1	1710	2.024-39	3.000	5.156	EY 6-4-6421-1X
1	1710	2.024-39	3.000	5.156	EY 6-4-6421X
1	1710	2.024-39	3.000	5.156	EY 6-4-7621-1
1	1710	2.024-39	3.000	5.156	EY 6-4-7631-1X
1	1710	2.024-39	3.000	5.156	EY 6-4-7641-1X
1	1760	2.024-39	3.000	5.188	EY 6.3-4-1141-1X
1	1760	2.024-39	3.000	5.188	EY 6.3-4-531
1	1760	2.024-39	3.000	5.188	EY 6.3-4-531-1
1	1760	2.024-39	3.000	5.188	EY 6.3-4-541-1X
1	1760	2.024-39	3.000	5.188	EY 6.3-4-541X
Q-145, Q-200, Q-240, Q-245, Q-300, Q-340, Q-345, Q-360, Q-365, Q-380, Q-390, QT-140, QT-230, QT-240, QT-330					
1	1480	1.875-10	2.750	4.406	EY 3-4-6671-1X
1	1550	1.875-10	2.750	4.406	EY 4-4-1941
1	1610	1.875-10	2.750	5.000	EY 5-4-2501
QT-340					
1	1550	1.875-10	2.750	4.406	EY 4-4-1941
1	1610	1.875-10	2.750	5.000	EY 5-4-2501
R-100					
1	1480/1550	1.960-10	2.750	3.375	CF 4-1-2661
1	1710	1.960-10	2.750	3.312	CF 6-1-1461
1	1710	1.960-10	2.750	5.250	EY 6-4-4361X
1	1710	1.960-10	2.750	6.500	EY 6-4-4481X <i>High angle yoke</i>
R-140					
1	1480/1550	1.960-10	2.750	3.375	CF 4-1-2661
1	1710	1.960-10	2.750	3.312	CF 6-1-1461
1	1610	1.960-10	2.750	5.125	EY 5-4-5281X
1	1710	1.960-10	2.750	5.250	EY 6-4-4361X
1	1710	1.960-10	2.750	6.500	EY 6-4-4481X <i>High angle yoke</i>
R-143					
1	1810	2.024-39	2.750	5.625	EY 6.5-4-2781-1
1	1810	2.024-39	2.750	5.625	EY 6.5-4-3571-1X

*C/L to End of Hub for EY (End Yoke); Flange Face to End of Hub for CF (Companion Flange)

■ Hub machined for speedometer gear



Pos	Series	Spline Data	Hub Dia	* to End of Hub	End Fitting Part Number
R-144					
1	SPL140	2.024-39	2.750	5.250	EY 140-4-1421-1
1	SPL140	2.024-39	2.750	5.250	EY 140-4-1431-1X
1	1710	2.024-39	2.750	5.250	EY 6-4-5521-1
1	1810	2.024-39	2.750	5.625	EY 6.5-4-2781-1
1	1810	2.024-39	2.750	5.625	EY 6.5-4-3571-1X

R-155					
1	SPL140	2.024-39	2.750	5.250	EY 140-4-1421-1
1	SPL140	2.024-39	2.750	5.250	EY 140-4-1431-1X
1	1610	2.024-39	2.750	5.125	EY 5-4-5421
1	1610	2.024-39	2.750	5.938	EY 5-4-5441 <i>High angle yoke</i>
1	1610	2.024-39	2.750	5.125	EY 5-4-6951X
1	1610	2.024-39	2.750	5.938	EY 5-4-6961X <i>High angle yoke</i>
1	1710	2.024-39	2.750	6.500	EY 6-4-5501
1	1710	2.024-39	2.750	6.500	EY 6-4-5501-1 <i>High angle yoke</i>
1	1710	2.024-39	2.750	5.250	EY 6-4-5521
1	1710	2.024-39	2.750	5.250	EY 6-4-5521-1
1	1710	2.024-39	2.750	6.500	EY 6-4-6871-1X <i>High angle yoke</i>
1	1710	2.024-39	2.750	6.500	EY 6-4-6871X
1	1710	2.024-39	2.750	5.250	EY 6-4-6951-1X
1	1710	2.024-39	2.750	5.250	EY 6-4-6951X
1	1810	2.024-39	2.750	5.531	EY 6.5-4-2781
1	1810	2.024-39	2.750	5.625	EY 6.5-4-2781-1
1	1810	2.024-39	2.750	5.625	EY 6.5-4-3571-1X
1	1810	2.024-39	2.750	5.531	EY 6.5-4-3571X

R-160					
1	1480/1550	1.960-10	2.750	3.375	CF 4-1-2661
1	1710	1.960-10	2.750	3.312	CF 6-1-1461
1	1610	1.960-10	2.750	5.125	EY 5-4-5281X
1	1710	1.960-10	2.750	5.250	EY 6-4-4361X
1	1710	1.960-10	2.750	6.500	EY 6-4-4481X <i>High angle yoke</i>

R-170, R-180					
1	1710	2.250-10	3.000	3.750	CF 6-1-1421 .250 deep counterbore at hub end
1	1810	2.250-10	3.000	3.750	CF 6.5-1-211 .250 deep counterbore at hub end
1	1650	2.250-10	3.000	5.625	EY 5-4-6891X
1	1710	2.250-10	3.000	6.062	EY 6-4-1991
1	1710	2.250-10	3.000	6.062	EY 6-4-4411-1X
1	1710	2.250-10	3.000	6.062	EY 6-4-4411X
1	1710	2.250-10	3.000	7.188	EY 6-4-6891X <i>High angle yoke</i>
1	1760	2.250-10	3.000	5.844	EY 6.3-4-731X
1	1810	2.250-10	3.000	5.844	EY 6.5-4-2551X

R-200					
1	1480/1550	1.960-10	2.750	3.375	CF 4-1-2661
1	1710	1.960-10	2.750	3.312	CF 6-1-1461
1	1610	1.960-10	2.750	5.125	EY 5-4-5281X
1	1710	1.960-10	2.750	5.250	EY 6-4-4361X
1	1710	1.960-10	2.750	6.500	EY 6-4-4481X <i>High angle yoke</i>
1	1810	2.024-39	2.750	5.625	EY 6.5-4-2781-1
1	1810	2.024-39	2.750	5.625	EY 6.5-4-3571-1X

Pos	Series	Spline Data	Hub Dia	* to End of Hub	End Fitting Part Number
R-220, R-230, R-240					
1	1480/1550	1.960-10	2.750	3.375	CF 4-1-2661
1	1710	1.960-10	2.750	3.312	CF 6-1-1461
1	1610	1.960-10	2.750	5.125	EY 5-4-5281X
1	1710	1.960-10	2.750	5.250	EY 6-4-4361X
1	1710	1.960-10	2.750	6.500	EY 6-4-4481X <i>High angle yoke</i>

R-255					
1	1610	2.024-39	2.750	5.125	EY 5-4-6951X
1	1610	2.024-39	2.750	5.938	EY 5-4-6961X <i>High angle yoke</i>
1	1710	2.024-39	2.750	6.500	EY 6-4-6871X
1	1710	2.024-39	2.750	4.812	EY 6-4-6941X
1	1710	2.024-39	2.750	5.250	EY 6-4-6951-1X
1	1710	2.024-39	2.750	5.250	EY 6-4-6951X
1	1810	2.024-39	2.750	5.625	EY 6.5-4-2781-1
1	1810	2.024-39	2.750	5.625	EY 6.5-4-3571-1X
1	1810	2.024-39	2.750	5.531	EY 6.5-4-3571X

R-270					
1	1610	2.024-39	3.000	5.531	EY 5-4-6281X
1	1710	2.024-39	3.000	6.250	EY 6-4-6391-1X <i>High angle yoke</i>
1	1710	2.024-39	3.000	6.250	EY 6-4-6391X <i>High angle yoke</i>
1	1710	2.024-39	3.000	5.156	EY 6-4-6411X
1	1710	2.024-39	3.000	5.156	EY 6-4-6421-1X
1	1710	2.024-39	3.000	5.156	EY 6-4-6421X
1	1710	2.024-39	3.000	5.156	EY 6-4-7631-1X
1	1760	2.024-39	3.000	5.188	EY 6.3-4-541-1X
1	1760	2.024-39	3.000	5.188	EY 6.3-4-541X
1	1810	2.024-39	3.000	5.190	EY 6.5-4-3381-1X
1	1810	2.024-39	3.000	5.190	EY 6.5-4-3381X

R-300					
1	1480/1550	1.960-10	2.750	3.375	CF 4-1-2661
1	1710	1.960-10	2.750	3.312	CF 6-1-1461
1	1610	1.960-10	2.750	5.125	EY 5-4-5281X
1	1710	1.960-10	2.750	5.250	EY 6-4-4361X
1	1710	1.960-10	2.750	6.500	EY 6-4-4481X <i>High angle yoke</i>
1	1810	2.024-39	2.750	5.625	EY 6.5-4-2781-1
1	1810	2.024-39	2.750	5.625	EY 6.5-4-3571-1X

R-330, R-340					
1	1480/1550	1.960-10	2.750	3.375	CF 4-1-2661
1	1710	1.960-10	2.750	3.312	CF 6-1-1461
1	1610	1.960-10	2.750	5.125	EY 5-4-5281X
1	1710	1.960-10	2.750	5.250	EY 6-4-4361X
1	1710	1.960-10	2.750	6.500	EY 6-4-4481X <i>High angle yoke</i>

R-355					
1	1610	2.024-39	2.750	5.125	EY 5-4-6951X
1	1710	2.024-39	2.750	6.500	EY 6-4-6871X
1	1710	2.024-39	2.750	4.812	EY 6-4-6941X
1	1710	2.024-39	2.750	5.250	EY 6-4-6951X
1	1810	2.024-39	2.750	5.625	EY 6.5-4-2781-1
1	1810	2.024-39	2.750	5.625	EY 6.5-4-3571-1X
1	1810	2.024-39	2.750	5.531	EY 6.5-4-3571X

*C/L to End of Hub for EY (End Yoke); Flange Face to End of Hub for CF (Companion Flange)

■ Hub machined for speedometer gear



Important: See Safety Information in General Information Section (J300P-GI)

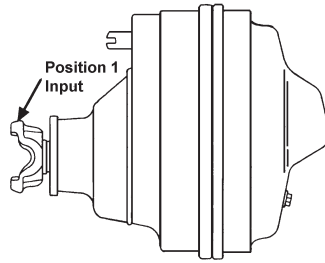

Pos	Series	Spline Data	Hub Dia	* to End of Hub	End Fitting Part Number
RF**-145					
1	1610	2.024-39	3.000	5.531	EY 5-4-6281X
1	1610	2.024-39	3.000	6.219	EY 5-4-6291X <i>High angle yoke</i>
1	1610	2.024-39	3.000	4.875	EY 5-4-6441-1X
1	1710	2.024-39	3.000	6.250	EY 6-4-6391-1X <i>High angle yoke</i>
1	1710	2.024-39	3.000	6.250	EY 6-4-6391X <i>High angle yoke</i>
1	1710	2.024-39	3.000	5.156	EY 6-4-6421-1X
1	1710	2.024-39	3.000	5.156	EY 6-4-6421X
1	1710	2.024-39	3.000	5.156	EY 6-4-7621-1
1	1710	2.024-39	3.000	5.156	EY 6-4-7631-1X
1	1710	2.024-39	3.000	5.156	EY 6-4-7641-1X
1	1760	2.024-39	3.000	5.188	EY 6.3-4-541X

RF**-155, RF**-156					
1	SPL140	2.024-39	2.750	5.250	EY 140-4-1421-1
1	SPL140	2.024-39	2.750	5.250	EY 140-4-1431-1X
1	1610	2.024-39	2.750	5.938	EY 5-4-6961X <i>High angle yoke</i>
1	1710	2.024-39	2.750	6.500	EY 6-4-5501
1	1710	2.024-39	2.750	6.500	EY 6-4-5501-1 <i>High angle yoke</i>
1	1710	2.024-39	2.750	5.250	EY 6-4-5521
1	1710	2.024-39	2.750	5.250	EY 6-4-5521-1
1	1710	2.024-39	2.750	6.500	EY 6-4-6871-1X <i>High angle yoke</i>
1	1710	2.024-39	2.750	6.500	EY 6-4-6871X
1	1710	2.024-39	2.750	5.250	EY 6-4-6951-1X
1	1710	2.024-39	2.750	5.250	EY 6-4-6951X
1	1810	2.024-39	2.750	5.125	EY 5-4-5421
1	1810	2.024-39	2.750	5.938	EY 5-4-5441 <i>High angle yoke</i>
1	1810	2.024-39	2.750	5.125	EY 5-4-6951X
1	1810	2.024-39	2.750	5.531	EY 6.5-4-2781
1	1810	2.024-39	2.750	5.625	EY 6.5-4-2781-1
1	1810	2.024-39	2.750	5.625	EY 6.5-4-3571-1X
1	1810	2.024-39	2.750	5.531	EY 6.5-4-3571X

RF**-160					
1	1610	2.390-46	3.250	4.938	EY 5-4-7341-1X
1	1710	2.390-46	3.250	5.391	EY 6-4-7181-1X
1	1710	2.390-46	3.250	5.391	EY 6-4-7181X
1	1760	2.390-46	3.250	5.062	EY 6.3-4-1041-1X
1	1760	2.390-46	3.250	5.062	EY 6.3-4-1041X
1	1810	2.390-46	3.250	5.156	EY 6.5-4-3731-1X

RF**-180					
1	1710	2.374-46	3.250	5.938	EY 6-4-6961-1X
1	1760	2.374-46	3.250	5.625	EY 6.3-4-861-1X
1	1760	2.374-46	3.250	5.625	EY 6.3-4-861X
1	1810	2.374-46	3.250	5.688	EY 6.5-4-3581-1X

Pos	Series	Spline Data	Hub Dia	* to End of Hub	End Fitting Part Number
RF**-355					
1	SPL140	2.024-39	2.750	5.250	EY 140-4-1421-1
1	SPL140	2.024-39	2.750	5.250	EY 140-4-1431-1X
1	1610	2.024-39	2.750	5.938	EY 5-4-6961X <i>High angle yoke</i>
1	1710	2.024-39	2.750	6.500	EY 6-4-5501
1	1710	2.024-39	2.750	6.500	EY 6-4-5501-1 <i>High angle yoke</i>
1	1710	2.024-39	2.750	5.250	EY 6-4-5521
1	1710	2.024-39	2.750	5.250	EY 6-4-5521-1
1	1710	2.024-39	2.750	6.500	EY 6-4-6871-1X <i>High angle yoke</i>
1	1710	2.024-39	2.750	6.500	EY 6-4-6871X
1	1710	2.024-39	2.750	5.250	EY 6-4-6951-1X
1	1710	2.024-39	2.750	5.250	EY 6-4-6951X
1	1810	2.024-39	2.750	5.125	EY 5-4-5421
1	1810	2.024-39	2.750	5.938	EY 5-4-5441 <i>High angle yoke</i>
1	1810	2.024-39	2.750	5.125	EY 5-4-6951X
1	1810	2.024-39	2.750	5.531	EY 6.5-4-2781
1	1810	2.024-39	2.750	5.625	EY 6.5-4-2781-1
1	1810	2.024-39	2.750	5.625	EY 6.5-4-3571-1X
1	1810	2.024-39	2.750	5.531	EY 6.5-4-3571X

RF**-356					
1	1710	2.024-39	2.750	6.500	EY 6-4-5501-1 <i>High angle yoke</i>

RL-170					
1	1710	2.250-10	3.000	3.750	CF 6-1-1421 .250 deep counterbore at hub end
1	1810	2.250-10	3.000	3.750	CF 6.5-1-211 .250 deep counterbore at hub end
1	1650	2.250-10	3.000	5.625	EY 5-4-6891X
1	1710	2.250-10	3.000	6.062	EY 6-4-4411-1X
1	1710	2.250-10	3.000	6.062	EY 6-4-4411X
1	1710	2.250-10	3.000	7.188	EY 6-4-6891X <i>High angle yoke</i>
1	1760	2.250-10	3.000	5.844	EY 6.3-4-731X

RS**-120, RS**-125, RS**-140					
1	SPL140	1.774-34	2.500	4.950	EY 140-4-251-1
1	SPL140	1.774-34	2.500	4.950	EY 140-4-261-1X
1	SPL90	1.774-34	2.500	4.110	EY 90-4-751-1
1	SPL90	1.774-34	2.500	4.110	EY 90-4-761-1X
1	1410	1.774-34	2.500	4.469	EY 3-4-7541-1
1	1410	1.774-34	2.500	4.188	EY 3-4-7551
1	1410	1.774-34	2.500	4.188	EY 3-4-7551-1
1	1410	1.774-34	2.500	4.188	EY 3-4-8061X
1	1480	1.774-34	2.500	4.469	EY 3-4-8051-1X
1	1480	1.774-34	2.500	4.188	EY 3-4-8061-1X
1	1550	1.774-34	2.500	4.700	EY 4-4-4101-1
1	1550	1.774-34	2.500	4.700	EY 4-4-4101-2 <i>Attaching hardware by OEM</i>

*C/L to End of Hub for EY (End Yoke); Flange Face to End of Hub for CF (Companion Flange)

■ Hub machined for speedometer gear



Pos	Series	Spline Data	Hub Dia	* to End of Hub	End Fitting Part Number
RS-**-120, RS-**-125, RS-**-140 (Continued)					
1	1550	1.774-34	2.500	4.700	EY 4-4-4111-1X
1	1610	1.774-34	2.500	4.875	EY 5-4-5571-1
1	1610	1.774-34	2.500	4.875	EY 5-4-5621-1X
1	1710	1.774-34	2.500	4.875	EY 6-4-5131-1X
1	1710	1.774-34	2.500	4.875	EY 6-4-5131X
1	1710	1.774-34	2.500	4.875	EY 6-4-6331
1	1710	1.774-34	2.500	4.875	EY 6-4-6331-1

Pos	Series	Spline Data	Hub Dia	* to End of Hub	End Fitting Part Number
RS-**-144					
1	SPL140	2.024-39	3.000	5.680	EY 140-4-211-1
1	SPL140	2.024-39	3.000	5.680	EY 140-4-231-1X
1	SPL170	2.024-39	3.000	5.090	EY 170-4-641-1
1	SPL170	2.024-39	3.000	5.090	EY 170-4-651-1X
1	SPL170	2.024-39	3.000	6.391	EY 170-4-661-1
					<i>High angle yoke</i>
1	SPL170	2.024-39	3.000	6.391	EY 170-4-671-1X
					<i>High angle yoke</i>
1	SPL90	2.024-39	3.000	4.625	EY 90-4-311-1
1	SPL90	2.024-39	3.000	4.625	EY 90-4-321-1X
1	1480	2.024-39	3.000	4.281	EY 3-4-8861
1	1480	2.024-39	3.000	4.281	EY 3-4-8871X
1	1550	2.024-39	3.000	5.000	EY 4-4-5261-1
1	1550	2.024-39	3.000	5.000	EY 4-4-6731-1X
1	1610	2.024-39	3.000	6.219	EY 5-4-6241
					<i>High angle yoke</i>
1	1610	2.024-39	3.000	6.219	EY 5-4-6241-1
					<i>High angle yoke</i>
1	1610	2.024-39	3.000	5.531	EY 5-4-6271
1	1610	2.024-39	3.000	5.531	EY 5-4-6281X
1	1610	2.024-39	3.000	6.219	EY 5-4-6291-1X
					<i>High angle yoke</i>
1	1610	2.024-39	3.000	6.219	EY 5-4-6291X
					<i>High angle yoke</i>
1	1610	2.024-39	3.000	4.875	EY 5-4-6421-1
1	1610	2.024-39	3.000	4.875	EY 5-4-6441-1X
1	1710	2.024-39	3.000	6.250	EY 6-4-6371
					<i>High angle yoke</i>
1	1710	2.024-39	3.000	6.250	EY 6-4-6371-1
					<i>High angle yoke</i>
1	1710	2.024-39	3.000	6.250	EY 6-4-6391-1X
					<i>High angle yoke</i>
1	1710	2.024-39	3.000	6.250	EY 6-4-6391X
					<i>High angle yoke</i>
1	1710	2.024-39	3.000	5.156	EY 6-4-6401
1	1710	2.024-39	3.000	5.156	EY 6-4-6401-1
1	1710	2.024-39	3.000	5.156	EY 6-4-6421-1X
1	1710	2.024-39	3.000	5.156	EY 6-4-6421X
1	1710	2.024-39	3.000	5.156	EY 6-4-7621-1
1	1760	2.024-39	3.000	5.188	EY 6-3-4-1141-1X
1	1760	2.024-39	3.000	5.188	EY 6-3-4-531
1	1760	2.024-39	3.000	5.188	EY 6-3-4-531-1
1	1810	2.024-39	3.000	5.190	EY 6-5-4-3371
1	1810	2.024-39	3.000	5.190	EY 6-5-4-3371-1

Pos	Series	Spline Data	Hub Dia	* to End of Hub	End Fitting Part Number
RS-**-145					
1	SPL140	2.024-39	3.000	5.680	EY 140-4-211-1
1	SPL140	2.024-39	3.000	5.680	EY 140-4-231-1X
1	SPL170	2.024-39	3.000	5.090	EY 170-4-641-1
1	SPL170	2.024-39	3.000	5.090	EY 170-4-651-1X
1	SPL170	2.024-39	3.000	6.391	EY 170-4-661-1
					<i>High angle yoke</i>
1	SPL170	2.024-39	3.000	6.391	EY 170-4-671-1X
					<i>High angle yoke</i>

Pos	Series	Spline Data	Hub Dia	* to End of Hub	End Fitting Part Number
RS-**-145 (Continued)					
1	SPL90	2.024-39	3.000	4.625	EY 90-4-311-1
1	SPL90	2.024-39	3.000	4.625	EY 90-4-321-1X
1	1480	2.024-39	3.000	4.281	EY 3-4-8861
1	1480	2.024-39	3.000	4.281	EY 3-4-8871X
1	1550	2.024-39	3.000	5.000	EY 4-4-5261-1
1	1550	2.024-39	3.000	5.000	EY 4-4-6731-1X
1	1610	2.024-39	3.000	6.219	EY 5-4-6241
					<i>High angle yoke</i>
1	1610	2.024-39	3.000	6.219	EY 5-4-6241-1
					<i>High angle yoke</i>
1	1610	2.024-39	3.000	5.531	EY 5-4-6271
1	1610	2.024-39	3.000	5.531	EY 5-4-6281X
1	1610	2.024-39	3.000	6.219	EY 5-4-6291-1X
					<i>High angle yoke</i>
1	1610	2.024-39	3.000	6.219	EY 5-4-6291X
					<i>High angle yoke</i>
1	1610	2.024-39	3.000	4.875	EY 5-4-6421-1
1	1610	2.024-39	3.000	4.875	EY 5-4-6441-1X
1	1710	2.024-39	3.000	6.250	EY 6-4-6371
					<i>High angle yoke</i>
1	1710	2.024-39	3.000	6.250	EY 6-4-6371-1
					<i>High angle yoke</i>
1	1710	2.024-39	3.000	6.250	EY 6-4-6391-1X
					<i>High angle yoke</i>
1	1710	2.024-39	3.000	6.250	EY 6-4-6391X
					<i>High angle yoke</i>
1	1710	2.024-39	3.000	5.156	EY 6-4-6401
1	1710	2.024-39	3.000	5.156	EY 6-4-6401-1
1	1710	2.024-39	3.000	5.156	EY 6-4-6421-1X
1	1710	2.024-39	3.000	5.156	EY 6-4-6421X
1	1710	2.024-39	3.000	5.156	EY 6-4-7621-1
1	1760	2.024-39	3.000	5.188	EY 6-3-4-1141-1X
1	1760	2.024-39	3.000	5.188	EY 6-3-4-531
1	1760	2.024-39	3.000	5.188	EY 6-3-4-531-1
1	1810	2.024-39	3.000	5.190	EY 6-5-4-3371
1	1810	2.024-39	3.000	5.190	EY 6-5-4-3371-1
1	1810	2.024-39	3.000	5.190	EY 6-5-4-3381-1X
1	1810	2.024-39	3.000	5.190	EY 6-5-4-3381X

Pos	Series	Spline Data	Hub Dia	* to End of Hub	End Fitting Part Number
RS-**-160					
1	SPL140	2.390-46	3.250	5.660	EY 140-4-301-1
1	SPL140	2.390-46	3.250	5.660	EY 140-4-311-1X
1	SPL170	2.390-46	3.250	5.100	EY 170-4-711-1
1	SPL170	2.390-46	3.250	5.100	EY 170-4-721-1X
1	SPL170	2.390-46	3.250	6.438	EY 170-4-731-1
1	SPL170	2.390-46	3.250	6.438	EY 170-4-741-1X
					<i>High angle yoke</i>
1	SPL250	2.390-46	3.250	5.312	EY 250-4-341-1
1	SPL250	2.390-46	3.250	5.312	EY 250-4-351-1X
1	SPL90	2.390-46	3.250	4.641	EY 90-4-331-1
1	SPL90	2.390-46	3.250	4.641	EY 90-4-341-1X
1	1610	2.390-46	3.250	4.938	EY 5-4-7331-1
1	1610	2.390-46	3.250	4.938	EY 5-4-7341-1X
1	1710	2.390-46	3.250	5.391	EY 6-4-7161
1	1710	2.390-46	3.250	5.391	EY 6-4-7161-1
1	1710	2.390-46	3.250	5.391	EY 6-4-7181-1X
1	1710	2.390-46	3.250	5.391	EY 6-4-7181X
1	1710	2.390-46	3.250	6.500	EY 6-4-7761
					<i>High angle yoke</i>

Continued on next page

*C/L to End of Hub for EY (End Yoke); Flange Face to End of Hub for CF (Companion Flange)

■ Hub machined for speedometer gear



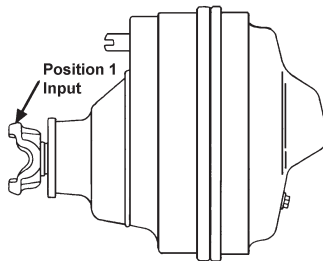

Pos	Series	Spline Data	Hub Dia	* to End of Hub	End Fitting Part Number
-----	--------	-------------	---------	-----------------	-------------------------

RS--160 (Continued)**

1	1710	2.390-46	3.250	6.500	EY 6-4-7761-1 <i>High angle yoke</i>
1	1710	2.390-46	3.250	6.500	EY 6-4-7771-1X <i>High angle yoke</i>
1	1710	2.390-46	3.250	6.500	EY 6-4-7771X <i>High angle yoke</i>
1	1760	2.390-46	3.250	5.062	EY 6.3-4-1031
1	1760	2.390-46	3.250	5.062	EY 6.3-4-1031-1
1	1760	2.390-46	3.250	5.062	EY 6.3-4-1041-1X
1	1760	2.390-46	3.250	5.062	EY 6.3-4-1041X
1	1810	2.390-46	3.250	5.156	EY 6.5-4-3721
1	1810	2.390-46	3.250	5.156	EY 6.5-4-3721-1
1	1810	2.390-46	3.250	5.156	EY 6.5-4-3731-1X
1	1810	2.390-46	3.250	5.156	EY 6.5-4-3731X

RS--180**

1	SPL140	2.374-46	3.250	6.210	EY 140-4-271-1
1	SPL140	2.374-46	3.250	6.210	EY 140-4-291-1X
1	SPL170	2.374-46	3.250	5.760	EY 170-4-571-1
1	SPL170	2.374-46	3.250	5.760	EY 170-4-591-1X
1	SPL170	2.374-46	3.250	7.250	EY 170-4-601-1 <i>High angle yoke</i>
1	SPL170	2.374-46	3.250	7.250	EY 170-4-611-1X <i>High angle yoke</i>
1	SPL170	2.390-46	3.250	6.438	EY 170-4-741-1X <i>High angle yoke</i>
1	SPL250	2.374-46	3.250	5.870	EY 250-4-281-1
1	SPL250	2.374-46	3.250	5.870	EY 250-4-301-1X
1	SPL90	2.374-46	3.250	5.188	EY 90-4-351-1
1	SPL90	2.374-46	3.250	5.188	EY 90-4-361-1X
1	1610	2.374-46	3.250	4.547	EY 5-4-7351-1
1	1610	2.374-46	3.250	4.547	EY 5-4-7361-1X
1	1710	2.374-46	3.250	5.938	EY 6-4-5931
1	1710	2.374-46	3.250	5.938	EY 6-4-5931-1
1	1710	2.374-46	3.250	5.938	EY 6-4-6961-1X
1	1710	2.374-46	3.250	5.938	EY 6-4-6961X
1	1710	2.374-46	3.250	6.938	EY 6-4-7831 <i>High angle yoke</i>
1	1710	2.374-46	3.250	6.938	EY 6-4-7831-1 <i>High angle yoke</i>
1	1710	2.374-46	3.250	6.938	EY 6-4-7851-1X <i>High angle yoke</i>
1	1710	2.374-46	3.250	6.938	EY 6-4-7851X <i>High angle yoke</i>
1	1760	2.374-46	3.250	5.625	EY 6.3-4-291
1	1760	2.374-46	3.250	5.625	EY 6.3-4-291-1
1	1760	2.374-46	3.250	5.625	EY 6.3-4-861-1X
1	1760	2.374-46	3.250	5.625	EY 6.3-4-861X
1	1810	2.374-46	3.250	5.688	EY 6.5-4-3201
1	1810	2.374-46	3.250	5.688	EY 6.5-4-3201-1
1	1810	2.374-46	3.250	5.688	EY 6.5-4-3581-1X
1	1810	2.374-46	3.250	5.688	EY 6.5-4-3581X

Pos	Series	Spline Data	Hub Dia	* to End of Hub	End Fitting Part Number
-----	--------	-------------	---------	-----------------	-------------------------

RS--185, RS-**-186**

1	SPL140	2.374-46	3.250	6.210	EY 140-4-271-1
1	SPL140	2.374-46	3.250	6.210	EY 140-4-291-1X
1	SPL170	2.374-46	3.250	5.760	EY 170-4-571-1
1	SPL170	2.374-46	3.250	5.760	EY 170-4-591-1X
1	SPL170	2.374-46	3.250	7.250	EY 170-4-601-1 <i>High angle yoke</i>
1	SPL170	2.374-46	3.250	7.250	EY 170-4-611-1X <i>High angle yoke</i>
1	SPL250	2.374-46	3.250	5.870	EY 250-4-281-1
1	SPL250	2.374-46	3.250	5.870	EY 250-4-301-1X
1	SPL90	2.374-46	3.250	5.188	EY 90-4-351-1
1	SPL90	2.374-46	3.250	5.188	EY 90-4-361-1X
1	1610	2.374-46	3.250	4.547	EY 5-4-7351-1
1	1610	2.374-46	3.250	4.547	EY 5-4-7361-1X
1	1710	2.374-46	3.250	5.938	EY 6-4-5931
1	1710	2.374-46	3.250	5.938	EY 6-4-5931-1
1	1710	2.374-46	3.250	5.938	EY 6-4-6961-1X
1	1710	2.374-46	3.250	6.938	EY 6-4-7831 <i>High angle yoke</i>
1	1710	2.374-46	3.250	6.938	EY 6-4-7831-1 <i>High angle yoke</i>
1	1710	2.374-46	3.250	6.938	EY 6-4-7851-1X <i>High angle yoke</i>
1	1710	2.374-46	3.250	6.938	EY 6-4-7851X <i>High angle yoke</i>
1	1760	2.374-46	3.250	5.625	EY 6.3-4-291
1	1760	2.374-46	3.250	5.625	EY 6.3-4-291-1
1	1760	2.374-46	3.250	5.625	EY 6.3-4-861-1X
1	1760	2.374-46	3.250	5.625	EY 6.3-4-861X
1	1810	2.374-46	3.250	5.688	EY 6.5-4-3201
1	1810	2.374-46	3.250	5.688	EY 6.5-4-3201-1
1	1810	2.374-46	3.250	5.688	EY 6.5-4-3581-1X
1	1810	2.374-46	3.250	5.688	EY 6.5-4-3581X

RS--210, RS-**-220, RS-**-230**

1	SPL140	1.774-34	2.500	4.950	EY 140-4-251-1
1	SPL140	1.774-34	2.500	4.950	EY 140-4-261-1X
1	SPL90	1.774-34	2.500	4.110	EY 90-4-751-1
1	SPL90	1.774-34	2.500	4.110	EY 90-4-761-1X
1	1410	1.774-34	2.500	4.469	EY 3-4-7541-1
1	1410	1.774-34	2.500	4.188	EY 3-4-7551
1	1410	1.774-34	2.500	4.188	EY 3-4-7551-1
1	1410	1.774-34	2.500	4.188	EY 3-4-8061X
1	1480	1.774-34	2.500	4.469	EY 3-4-8051-1X
1	1480	1.774-34	2.500	4.188	EY 3-4-8061-1X
1	1550	1.774-34	2.500	4.700	EY 4-4-4101-1
1	1550	1.774-34	2.500	4.700	EY 4-4-4101-2 <i>Attaching hardware by OEM</i>
1	1550	1.774-34	2.500	4.700	EY 4-4-4111-1X
1	1610	1.774-34	2.500	4.875	EY 5-4-5571-1

*C/L to End of Hub for EY (End Yoke); Flange Face to End of Hub for CF (Companion Flange)

■ Hub machined for speedometer gear



Pos	Series	Spline Data	Hub Dia	* to End of Hub	End Fitting Part Number
-----	--------	-------------	---------	-----------------	-------------------------

RS--210, RS-**-220, RS-**-230 (Continued)**

1	1610	1.774-34	2.500	4.875	EY 5-4-5621-1X
1	1710	1.774-34	2.500	4.875	EY 6-4-5131-1X
1	1710	1.774-34	2.500	4.875	EY 6-4-5131X
1	1710	1.774-34	2.500	4.875	EY 6-4-6331
1	1710	1.774-34	2.500	4.875	EY 6-4-6331-1

RS--240**

1	SPL140	2.024-39	3.000	5.680	EY 140-4-211-1
1	SPL140	2.024-39	3.000	5.680	EY 140-4-231-1X
1	SPL140	2.024-39	3.000	5.680	EY 140-4-241-1X
1	SPL170	2.024-39	3.000	5.090	EY 170-4-641-1
1	SPL170	2.024-39	3.000	5.090	EY 170-4-651-1X
1	SPL170	2.024-39	3.000	6.391	EY 170-4-661-1 <i>High angle yoke</i>
1	SPL170	2.024-39	3.000	6.391	EY 170-4-671-1X <i>High angle yoke</i>
1	SPL90	2.024-39	3.000	4.625	EY 90-4-311-1
1	SPL90	2.024-39	3.000	4.625	EY 90-4-321-1X
1	1480	2.024-39	3.000	4.281	EY 3-4-8861
1	1480	2.024-39	3.000	4.281	EY 3-4-8871X
1	1550	2.024-39	3.000	5.000	EY 4-4-5261-1
1	1550	2.024-39	3.000	5.000	EY 4-4-6731-1X
1	1610	2.024-39	3.000	6.219	EY 5-4-6241 <i>High angle yoke</i>
1	1610	2.024-39	3.000	6.219	EY 5-4-6241-1 <i>High angle yoke</i>
1	1610	2.024-39	3.000	5.531	EY 5-4-6271
1	1610	2.024-39	3.000	5.531	EY 5-4-6281X
1	1610	2.024-39	3.000	6.219	EY 5-4-6291-1X <i>High angle yoke</i>
1	1610	2.024-39	3.000	6.219	EY 5-4-6291X <i>High angle yoke</i>
1	1610	2.024-39	3.000	4.875	EY 5-4-6421-1
1	1610	2.024-39	3.000	4.875	EY 5-4-6441-1X
1	1710	2.024-39	3.000	6.250	EY 6-4-6371 <i>High angle yoke</i>
1	1710	2.024-39	3.000	6.250	EY 6-4-6371-1 <i>High angle yoke</i>
1	1710	2.024-39	3.000	6.250	EY 6-4-6391-1X <i>High angle yoke</i>
1	1710	2.024-39	3.000	6.250	EY 6-4-6391X <i>High angle yoke</i>
1	1710	2.024-39	3.000	5.156	EY 6-4-6401
1	1710	2.024-39	3.000	5.156	EY 6-4-6401-1
1	1710	2.024-39	3.000	5.156	EY 6-4-6421-1X
1	1710	2.024-39	3.000	5.156	EY 6-4-6421X
1	1710	2.024-39	3.000	5.156	EY 6-4-7621-1
1	1710	2.024-39	3.000	5.156	EY 6-4-7641-1X
1	1760	2.024-39	3.000	5.188	EY 6.3-4-1141-1X
1	1760	2.024-39	3.000	5.188	EY 6.3-4-531
1	1760	2.024-39	3.000	5.188	EY 6.3-4-531-1
1	1810	2.024-39	3.000	5.190	EY 6.5-4-3371
1	1810	2.024-39	3.000	5.190	EY 6.5-4-3371-1
1	1810	2.024-39	3.000	5.190	EY 6.5-4-3381-1X
1	1810	2.024-39	3.000	5.190	EY 6.5-4-3381X

RS--380**

1	SPL140	2.024-39	3.000	5.680	EY 140-4-211-1
1	SPL140	2.024-39	3.000	5.680	EY 140-4-231-1X
1	SPL140	2.024-39	3.000	5.680	EY 140-4-241-1X
1	SPL170	2.024-39	3.000	5.090	EY 170-4-641-1

Pos	Series	Spline Data	Hub Dia	* to End of Hub	End Fitting Part Number
-----	--------	-------------	---------	-----------------	-------------------------

RS--380 (Continued)**

1	SPL170	2.024-39	3.000	5.090	EY 170-4-651-1X
1	SPL170	2.024-39	3.000	6.391	EY 170-4-661-1 <i>High angle yoke</i>
1	SPL170	2.024-39	3.000	6.391	EY 170-4-691-1X <i>High angle yoke</i>
1	SPL170	2.024-39	3.000	5.090	EY 170-4-701-1X
1	SPL250	2.024-39	3.000	5.300	EY 250-4-311-1 <i>Counterbore at hub end.</i>
1	1710	2.024-39	3.000	6.250	EY 6-4-6371 <i>High angle yoke</i>
1	1710	2.024-39	3.000	6.250	EY 6-4-6371-1 <i>High angle yoke</i>
1	1710	2.024-39	3.000	6.250	EY 6-4-6391-1X <i>High angle yoke</i>
1	1710	2.024-39	3.000	6.250	EY 6-4-6391X <i>High angle yoke</i>
1	1710	2.024-39	3.000	5.156	EY 6-4-7621-1
1	1710	2.374-46	3.250	6.938	EY 6-4-7831 <i>High angle yoke</i>
1	1710	2.374-46	3.250	6.938	EY 6-4-7831-1 <i>High angle yoke</i>
1	1710	2.374-46	3.250	6.938	EY 6-4-7851-1X <i>High angle yoke</i>
1	1710	2.374-46	3.250	6.938	EY 6-4-7851X <i>High angle yoke</i>
1	1710	2.024-39	3.000	5.156	EY 6-4-8601-1X
1	1760	2.024-39	3.000	5.188	EY 6.3-4-1341-1X
1	1760	2.024-39	3.000	5.188	EY 6.3-4-531-1
1	1810	2.024-39	3.000	5.190	EY 6.5-4-3371-1
1	1810	2.024-39	3.000	5.190	EY 6.5-4-4191-1X

RT--180**

1	SPL170	2.374-46	3.250	5.760	EY 170-4-571-1
1	SPL170	2.374-46	3.250	5.760	EY 170-4-591-1X

RT-140, RT-240, RT-340

1	1480/1550	1.960-10	2.750	3.375	CF 4-1-2661
1	1710	1.960-10	2.750	3.312	CF 6-1-1461
1	1610	1.960-10	2.750	5.125	EY 5-4-5281X
1	1710	1.960-10	2.750	5.250	EY 6-4-4361X
1	1710	1.960-10	2.750	6.500	EY 6-4-4481X <i>High angle yoke</i>

R125, R128

1	1610	2.024-39	3.000	5.531	EY 5-4-6281X
1	1610	2.024-39	3.000	6.219	EY 5-4-6291X <i>High angle yoke</i>
1	1710	2.024-39	3.000	6.250	EY 6-4-6391-1X <i>High angle yoke</i>
1	1710	2.024-39	3.000	6.250	EY 6-4-6391X <i>High angle yoke</i>
1	1710	2.024-39	3.000	5.156	EY 6-4-6421-1X
1	1710	2.024-39	3.000	5.156	EY 6-4-6421X
1	1710	2.024-39	3.000	5.156	EY 6-4-7621-1
1	1710	2.024-39	3.000	5.156	EY 6-4-7631-1X
1	1710	2.024-39	3.000	5.156	EY 6-4-7641-1X

R180

1	1760	2.374-46	3.250	5.625	EY 6.3-4-301-1X
1	1760	2.374-46	3.250	5.625	EY 6.3-4-301X
1	1810	2.374-46	3.250	5.688	EY 6.5-4-3201
1	1810	2.374-46	3.250	5.688	EY 6.5-4-3201-1
1	1810	2.374-46	3.250	5.688	EY 6.5-4-3221-1X

Continued on next page

*C/L to End of Hub for EY (End Yoke); Flange Face to End of Hub for CF (Companion Flange)

■ Hub machined for speedometer gear



Important: See Safety Information in General Information Section (J300P-GI)

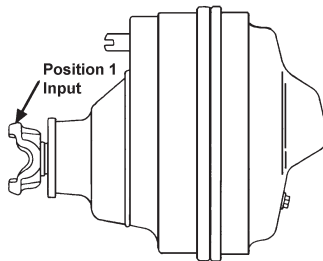

Pos	Series	Spline Data	Hub Dia	* to End of Hub	End Fitting Part Number
-----	--------	-------------	---------	-----------------	-------------------------

R180 (Continued)

1	1810	2.374-46	3.250	5.688	EY 6.5-4-3221X
1	1810	2.374-46	3.250	5.688	EY 6.5-4-3581-1X
1	1810	2.374-46	3.250	5.688	EY 6.5-4-3581X

R360

1	1480/1550	1.960-10	2.750	3.375	CF 4-1-2661
1	1710	1.960-10	2.750	3.312	CF 6-1-1461
1	1610	1.960-10	2.750	5.125	EY 5-4-5281X
1	1710	1.960-10	2.750	5.250	EY 6-4-4361X
1	1710	1.960-10	2.750	6.500	EY 6-4-4481X <i>High angle yoke</i>

R611

1	1610	2.024-39	3.000	5.531	EY 5-4-6281X
1	1610	2.024-39	3.000	6.219	EY 5-4-6291X <i>High angle yoke</i>
1	1710	2.024-39	3.000	6.250	EY 6-4-6391-1X <i>High angle yoke</i>
1	1710	2.024-39	3.000	6.250	EY 6-4-6391X <i>High angle yoke</i>
1	1710	2.024-39	3.000	5.156	EY 6-4-6421-1X
1	1710	2.024-39	3.000	5.156	EY 6-4-6421X
1	1710	2.024-39	3.000	5.156	EY 6-4-7621-1
1	1710	2.024-39	3.000	5.156	EY 6-4-7631-1X
1	1710	2.024-39	3.000	5.156	EY 6-4-7641-1X

S-170

1	1710	2.250-10	3.000	3.750	CF 6-1-1421 <i>.250 deep counterbore at hub end</i>
1	1810	2.250-10	3.000	3.750	CF 6.5-1-211 <i>.250 deep counterbore at hub end</i>
1	1650	2.250-10	3.000	5.625	EY 5-4-6891X
1	1710	2.250-10	3.000	6.062	EY 6-4-4411-1X
1	1710	2.250-10	3.000	6.062	EY 6-4-4411X
1	1710	2.250-10	3.000	7.188	EY 6-4-6891X <i>High angle yoke</i>
1	1760	2.250-10	3.000	5.844	EY 6.3-4-731X
1	1810	2.250-10	3.000	5.844	EY 6.5-4-2551X

SPRC1737, SPRC1925

1	SPL140	2.024-39	2.750	5.250	EY 140-4-1421-1 <i>.250 deep counterbore at hub end</i>
1	SPL140	2.024-39	2.750	5.250	EY 140-4-1431-1X <i>.250 deep counterbore at hub end</i>
1	1610	2.024-39	2.750	5.125	EY 5-4-5421
1	1610	2.024-39	2.750	5.938	EY 5-4-5441 <i>High angle yoke</i>
1	1610	2.024-39	2.750	5.125	EY 5-4-6951X
1	1610	2.024-39	2.750	5.938	EY 5-4-6961X <i>High angle yoke</i>
1	1710	2.024-39	2.750	6.500	EY 6-4-5501
1	1710	2.024-39	2.750	6.500	EY 6-4-5501-1 <i>High angle yoke</i>
1	1710	2.024-39	2.750	5.250	EY 6-4-5521
1	1710	2.024-39	2.750	5.250	EY 6-4-5521-1
1	1710	2.024-39	2.750	6.500	EY 6-4-6871-1X <i>High angle yoke</i>

Pos	Series	Spline Data	Hub Dia	* to End of Hub	End Fitting Part Number
-----	--------	-------------	---------	-----------------	-------------------------

SPRC1737, SPRC1925 (Continued)

1	1710	2.024-39	2.750	6.500	EY 6-4-6871X
1	1710	2.024-39	2.750	5.250	EY 6-4-6951-1X
1	1710	2.024-39	2.750	5.250	EY 6-4-6951X
1	1810	2.024-39	2.750	5.531	EY 6.5-4-2781
1	1810	2.024-39	2.750	5.625	EY 6.5-4-2781-1
1	1810	2.024-39	2.750	5.625	EY 6.5-4-3571-1X
1	1810	2.024-39	2.750	5.531	EY 6.5-4-3571X

T-270

1	1610	2.024-39	3.000	5.531	EY 5-4-6281X
1	1710	2.024-39	3.000	6.250	EY 6-4-6391-1X <i>High angle yoke</i>
1	1710	2.024-39	3.000	6.250	EY 6-4-6391X <i>High angle yoke</i>
1	1710	2.024-39	3.000	5.156	EY 6-4-6411X
1	1710	2.024-39	3.000	5.156	EY 6-4-6421-1X
1	1710	2.024-39	3.000	5.156	EY 6-4-6421X
1	1710	2.024-39	3.000	5.156	EY 6-4-7631-1X
1	1760	2.024-39	3.000	5.188	EY 6.3-4-541-1X
1	1760	2.024-39	3.000	5.188	EY 6.3-4-541X
1	1810	2.024-39	3.000	5.190	EY 6.5-4-3381-1X
1	1810	2.024-39	3.000	5.190	EY 6.5-4-3381X

U-100

1	1810	2.024-39	2.750	5.625	EY 6.5-4-2781-1
1	1810	2.024-39	2.750	5.625	EY 6.5-4-3571-1X

U-170

1	1710	2.250-10	3.000	3.750	CF 6-1-1421 <i>.250 deep counterbore at hub end</i>
1	1810	2.250-10	3.000	3.750	CF 6.5-1-211 <i>.250 deep counterbore at hub end</i>
1	1610	2.250-10	3.000	5.625	EY 5-4-6891X
1	1710	2.250-10	3.000	6.062	EY 6-4-4411X
1	1760	2.250-10	3.000	5.844	EY 6.3-4-731X
1	1810	2.250-10	3.000	5.844	EY 6.5-4-2551X

U-180

1	1710	2.250-10	3.000	3.750	CF 6-1-1421 <i>.250 deep counterbore at hub end</i>
1	1810	2.250-10	3.000	3.750	CF 6.5-1-211 <i>.250 deep counterbore at hub end</i>
1	1650	2.250-10	3.000	5.625	EY 5-4-6891X
1	1710	2.250-10	3.000	6.062	EY 6-4-4411-1X
1	1710	2.250-10	3.000	6.062	EY 6-4-4411X
1	1710	2.250-10	3.000	7.188	EY 6-4-6891X <i>High angle yoke</i>
1	1760	2.374-46	3.250	5.625	EY 6.3-4-301-1X
1	1760	2.374-46	3.250	5.625	EY 6.3-4-301X
1	1760	2.250-10	3.000	5.844	EY 6.3-4-731X
1	1810	2.250-10	3.000	5.844	EY 6.5-4-2551X
1	1810	2.374-46	3.250	5.688	EY 6.5-4-3201
1	1810	2.374-46	3.250	5.688	EY 6.5-4-3201-1

*C/L to End of Hub for EY (End Yoke); Flange Face to End of Hub for CF (Companion Flange)

■ Hub machined for speedometer gear



Pos	Series	Spline Data	Hub Dia	* to End of Hub	End Fitting Part Number
-----	--------	-------------	---------	-----------------	-------------------------

U-180 (Continued)

1	1810	2.374-46	3.250	5.688	EY 6.5-4-3221-1X
1	1810	2.374-46	3.250	5.688	EY 6.5-4-3221X
1	1810	2.374-46	3.250	5.688	EY 6.5-4-3581-1X
1	1810	2.374-46	3.250	5.688	EY 6.5-4-3581X

U-200

1	1480/1550	1.960-10	2.750	3.375	CF 4-1-2661
1	1710	1.960-10	2.750	3.312	CF 6-1-1461
1	1610	1.960-10	2.750	5.125	EY 5-4-5281X
1	1710	1.960-10	2.750	5.250	EY 6-4-4361X
1	1710	1.960-10	2.750	6.500	EY 6-4-4481X <i>High angle yoke</i>
1	1810	2.024-39	2.750	5.625	EY 6.5-4-2781-1
1	1810	2.024-39	2.750	5.625	EY 6.5-4-3571-1X

U-240

1	1610	1.960-10	2.750	5.125	EY 5-4-5281X
1	1610	2.024-39	2.750	5.125	EY 5-4-6951X
1	1610	2.024-39	2.750	5.938	EY 5-4-6961X <i>High angle yoke</i>
1	1710	1.960-10	2.750	5.250	EY 6-4-4361X
1	1710	1.960-10	2.750	6.500	EY 6-4-4481X <i>High angle yoke</i>
1	1710	2.024-39	2.750	6.500	EY 6-4-6871X
1	1710	2.024-39	2.750	4.812	EY 6-4-6941X
1	1710	2.024-39	2.750	5.250	EY 6-4-6951-1X
1	1710	2.024-39	2.750	5.250	EY 6-4-6951X
1	1810	2.024-39	2.750	5.625	EY 6.5-4-2781-1
1	1810	2.024-39	2.750	5.625	EY 6.5-4-3571-1X
1	1810	2.024-39	2.750	5.531	EY 6.5-4-3571X

U-270

1	1610	2.024-39	3.000	5.531	EY 5-4-6281X
1	1710	2.024-39	3.000	6.250	EY 6-4-6391-1X <i>High angle yoke</i>
1	1710	2.024-39	3.000	6.250	EY 6-4-6391X <i>High angle yoke</i>
1	1710	2.024-39	3.000	5.156	EY 6-4-6411X
1	1710	2.024-39	3.000	5.156	EY 6-4-6421-1X
1	1710	2.024-39	3.000	5.156	EY 6-4-6421X
1	1710	2.024-39	3.000	5.156	EY 6-4-7631-1X
1	1760	2.024-39	3.000	5.188	EY 6.3-4-541-1X
1	1760	2.024-39	3.000	5.188	EY 6.3-4-541X
1	1810	2.024-39	3.000	5.190	EY 6.5-4-3381-1X
1	1810	2.024-39	3.000	5.190	EY 6.5-4-3381X

U-300

1	1480/1550	1.960-10	2.750	3.375	CF 4-1-2661
1	1710	1.960-10	2.750	3.312	CF 6-1-1461
1	1610	1.960-10	2.750	5.125	EY 5-4-5281X
1	1710	1.960-10	2.750	5.250	EY 6-4-4361X
1	1710	1.960-10	2.750	6.500	EY 6-4-4481X <i>High angle yoke</i>
1	1810	2.024-39	2.750	5.625	EY 6.5-4-2781-1
1	1810	2.024-39	2.750	5.625	EY 6.5-4-3571-1X

U-340

1	1610	2.024-39	2.750	5.125	EY 5-4-6951X
1	1610	2.024-39	2.750	5.938	EY 5-4-6961X <i>High angle yoke</i>
1	1710	2.024-39	2.750	6.500	EY 6-4-6871X
1	1710	2.024-39	2.750	4.812	EY 6-4-6941X
1	1710	2.024-39	2.750	5.250	EY 6-4-6951-1X

Pos	Series	Spline Data	Hub Dia	* to End of Hub	End Fitting Part Number
-----	--------	-------------	---------	-----------------	-------------------------

U-340 (Continued)

1	1710	2.024-39	2.750	5.250	EY 6-4-6951X
1	1810	2.024-39	2.750	5.625	EY 6.5-4-2781-1
1	1810	2.024-39	2.750	5.625	EY 6.5-4-3571-1X
1	1810	2.024-39	2.750	5.531	EY 6.5-4-3571X

W-170

1	1710	2.250-10	3.000	3.750	CF 6-1-1421 <i>.250 deep counterbore at hub end</i>
1	1810	2.250-10	3.000	3.750	CF 6.5-1-211 <i>.250 deep counterbore at hub end</i>
1	1650	2.250-10	3.000	5.625	EY 5-4-6891X
1	1710	2.250-10	3.000	6.062	EY 6-4-4411-1X
1	1710	2.250-10	3.000	6.062	EY 6-4-4411X
1	1710	2.250-10	3.000	7.188	EY 6-4-6891X <i>High angle yoke</i>
1	1760	2.250-10	3.000	5.844	EY 6.3-4-731X
1	1810	2.250-10	3.000	5.844	EY 6.5-4-2551X

W-270

1	1610	2.024-39	3.000	5.531	EY 5-4-6281X
1	1710	2.024-39	3.000	6.250	EY 6-4-6391-1X <i>High angle yoke</i>
1	1710	2.024-39	3.000	6.250	EY 6-4-6391X <i>High angle yoke</i>
1	1710	2.024-39	3.000	5.156	EY 6-4-6411X
1	1710	2.024-39	3.000	5.156	EY 6-4-6421-1X
1	1710	2.024-39	3.000	5.156	EY 6-4-6421X
1	1710	2.024-39	3.000	5.156	EY 6-4-7631-1X
1	1760	2.024-39	3.000	5.188	EY 6.3-4-541-1X
1	1760	2.024-39	3.000	5.188	EY 6.3-4-541X
1	1810	2.024-39	3.000	5.190	EY 6.5-4-3381-1X
1	1810	2.024-39	3.000	5.190	EY 6.5-4-3381X

1357, 1758, 1768

1	1710	1.960-10	2.938	4.500	EY 6-4-2061
---	------	----------	-------	-------	-------------

2100

1	1610	2.024-39	2.750	5.125	EY 5-4-6951X
1	1610	2.024-39	2.750	5.938	EY 5-4-6961X <i>High angle yoke</i>
1	1710	2.024-39	2.750	6.500	EY 6-4-6871X
1	1710	2.024-39	2.750	4.812	EY 6-4-6941X
1	1710	2.024-39	2.750	5.250	EY 6-4-6951-1X
1	1710	2.024-39	2.750	5.250	EY 6-4-6951X
1	1810	2.024-39	2.750	5.625	EY 6.5-4-3571-1X
1	1810	2.024-39	2.750	5.531	EY 6.5-4-3571X

*C/L to End of Hub for EY (End Yoke); Flange Face to End of Hub for CF (Companion Flange)

■ Hub machined for speedometer gear



Important: See Safety Information in General Information Section (J300P-GI)

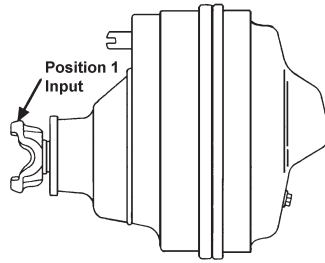

Pos	Series	Spline Data	Hub Dia	* to End of Hub	End Fitting Part Number
-----	--------	-------------	---------	-----------------	-------------------------

D135-S					
1	1480	1.790-34	2.375	4.219	EY 3-4-12101-1X
1	1480	1.750-10	2.375	4.219	EY 3-4-3571-1
1	1550	1.750-10	2.375	4.000	EY 4-4-2041-1
1	1550	1.790-34	2.375	4.000	EY 4-4-6961-1X
1	1610	1.750-10	2.375	4.188	EY 5-4-1481
1	1610	1.750-10	2.375	4.688	EY 5-4-1481-1
1	1610	1.790-34	2.375	4.125	EY 5-4-8571-1X

E2300SD					
1	1610	2.274-44	2.938	5.000	EY 5-4-8431-1X

F155-S					
1	SPL55	1.790-34	2.375	4.219	EY 55-4-31-1
1	SPL55	1.790-34	2.375	4.219	EY 55-4-41-1X
1	SPL90	1.790-34	2.375	5.625	EY 90-4-541-1
1	SPL90	1.790-34	2.375	5.625	EY 90-4-551-1X
1	1480	1.790-34	2.375	4.219	EY 3-4-12091-1
1	1480	1.790-34	2.375	4.219	EY 3-4-12101-1X
1	1550	1.790-34	2.375	4.000	EY 4-4-6951-1
1	1550	1.790-34	2.375	4.000	EY 4-4-6961-1X
1	1610	1.790-34	2.375	4.125	EY 5-4-8561-1
1	1610	1.790-34	2.375	4.125	EY 5-4-8571-1X

F170-S					
1	SPL55	1.790-34	2.375	4.219	EY 55-4-31-1
1	SPL55	1.790-34	2.375	4.219	EY 55-4-41-1X
1	SPL90	1.790-34	2.375	5.625	EY 90-4-541-1
1	SPL90	1.790-34	2.375	5.625	EY 90-4-551-1X
1	1480	1.790-34	2.375	4.219	EY 3-4-12091-1
1	1480	1.790-34	2.375	4.219	EY 3-4-12101-1X
1	1550	1.790-34	2.375	4.000	EY 4-4-6951-1
1	1550	1.790-34	2.375	4.000	EY 4-4-6961-1X
1	1610	1.790-34	2.375	4.125	EY 5-4-8561-1
1	1610	1.790-34	2.375	4.125	EY 5-4-8571-1X

G155-T					
1	SPL140	1.998-38	3.000	4.680	EY 140-4-901-1
1	SPL140	1.998-38	3.000	4.680	EY 140-4-911-1X
1	SPL90	1.998-38	3.000	4.250	EY 90-4-561-1
1	SPL90	1.998-38	3.000	4.250	EY 90-4-571-1X
1	1480	1.998-38	3.000	4.281	EY 3-4-12111-1
1	1480	1.998-38	3.000	4.281	EY 3-4-12121-1X
1	1550	1.998-38	3.000	4.500	EY 4-4-6971-1
1	1550	1.998-38	3.000	4.500	EY 4-4-6981-1X
1	1610	1.998-38	3.000	4.844	EY 5-4-8581-1
1	1610	1.998-38	3.000	4.844	EY 5-4-8591-1X
1	1710	1.998-38	3.000	4.844	EY 6-4-8651-1
1	1710	1.998-38	3.000	4.844	EY 6-4-8661-1X
1	1760	1.998-38	3.000	4.844	EY 6.3-4-1491-1
1	1760	1.998-38	3.000	4.844	EY 6.3-4-1501-1X

Pos	Series	Spline Data	Hub Dia	* to End of Hub	End Fitting Part Number
-----	--------	-------------	---------	-----------------	-------------------------

G175-S					
1	SPL140	1.998-38	3.000	4.680	EY 140-4-901-1
1	SPL140	1.998-38	3.000	4.680	EY 140-4-911-1X
1	SPL90	1.998-38	3.000	4.250	EY 90-4-561-1
1	SPL90	1.998-38	3.000	4.250	EY 90-4-571-1X
1	1480	1.998-38	3.000	4.281	EY 3-4-12111-1
1	1480	1.998-38	3.000	4.281	EY 3-4-12121-1X
1	1550	1.998-38	3.000	4.500	EY 4-4-6971-1
1	1550	1.998-38	3.000	4.500	EY 4-4-6981-1X
1	1610	1.998-38	3.000	4.844	EY 5-4-8581-1
1	1610	1.998-38	3.000	4.844	EY 5-4-8591-1X
1	1710	1.998-38	3.000	4.844	EY 6-4-8651-1
1	1710	1.998-38	3.000	4.844	EY 6-4-8661-1X
1	1710	1.998-38	3.000	4.840	EY 6-4-9951-1
1	1710	1.998-38	3.000	4.840	EY 6-4-9961-1X
1	1760	1.998-38	3.000	4.844	EY 6.3-4-1491-1
1	1760	1.998-38	3.000	4.844	EY 6.3-4-1501-1X

G175-T, G190-S					
1	SPL140	1.998-38	3.000	4.680	EY 140-4-901-1
1	SPL140	1.998-38	3.000	4.680	EY 140-4-911-1X
1	SPL90	1.998-38	3.000	4.250	EY 90-4-561-1
1	SPL90	1.998-38	3.000	4.250	EY 90-4-571-1X
1	1480	1.998-38	3.000	4.281	EY 3-4-12111-1
1	1480	1.998-38	3.000	4.281	EY 3-4-12121-1X
1	1550	1.998-38	3.000	4.500	EY 4-4-6971-1
1	1550	1.998-38	3.000	4.500	EY 4-4-6981-1X
1	1610	1.998-38	3.000	4.844	EY 5-4-8581-1
1	1610	1.998-38	3.000	4.844	EY 5-4-8591-1X
1	1710	1.998-38	3.000	4.844	EY 6-4-8661-1X
1	1710	1.998-38	3.000	4.840	EY 6-4-9951-1
1	1710	1.998-38	3.000	4.840	EY 6-4-9961-1X
1	1760	1.998-38	3.000	4.844	EY 6.3-4-1491-1
1	1760	1.998-38	3.000	4.844	EY 6.3-4-1501-1X

G190-T					
1	1710	1.998-38	3.000	4.840	EY 6-4-9951-1

J175-S, J190-S, J210-S, J220-S					
1	1610	2.114-32	3.000	2.844	CF 5-1-6691 <i>.424 deep counterbore at hub end</i>
1	1610	2.114-32	3.000	2.844	CF 5-1-6701X <i>.424 deep counterbore at hub end</i>
1	SPL140	2.114-32	3.000	4.810	EY 140-4-921-1
1	SPL140	2.114-32	3.000	4.810	EY 140-4-931-1X
1	SPL170	2.114-32	3.000	5.000	EY 170-4-891-1
1	SPL170	2.114-32	3.000	5.000	EY 170-4-901-1X
1	SPL170	2.114-32	3.000	6.312	EY 170-4-951-1 <i>High angle yoke</i>
1	SPL170	2.114-32	3.000	6.312	EY 170-4-961-1X <i>High angle yoke</i>
1	SPL250	2.114-32	3.000	5.240	EY 250-4-411-1

*C/L to End of Hub for EY (End Yoke); Flange Face to End of Hub for CF (Companion Flange)

■ Hub machined for speedometer gear



Pos	Series	Spline Data	Hub Dia	* to End of Hub	End Fitting Part Number
J175-S, J190-S, J210-S, J220-S (Continued)					
1	SPL250	2.114-32	3.000	5.240	EY 250-4-421-1X
1	SPL90	2.114-32	3.000	4.375	EY 90-4-581-1
1	SPL90	2.114-32	3.000	4.375	EY 90-4-591-1X
1	1480	2.114-32	3.000	4.281	EY 3-4-13341-1
1	1480	2.114-32	3.000	4.281	EY 3-4-13351-1X
1	1550	2.114-32	3.000	4.312	EY 4-4-6991-1
1	1550	2.114-32	3.000	4.312	EY 4-4-7001-1X
1	1610	2.114-32	3.000	5.375	EY 5-4-7221X
1	1610	2.114-32	3.000	5.375	EY 5-4-8601-1
1	1610	2.114-32	3.000	5.375	EY 5-4-8611-1X
1	1610	2.114-32	3.000	6.000	EY 5-4-8681-1
					<i>High angle yoke</i>
1	1610	2.114-32	3.000	6.000	EY 5-4-8691-1X
					<i>High angle yoke</i>
1	1710	2.114-32	3.000	4.562	EY 6-4-5811
1	1710	2.114-32	3.000	4.562	EY 6-4-7221X
1	1710	2.114-32	3.000	4.562	EY 6-4-8671-1
1	1710	2.114-32	3.000	4.562	EY 6-4-8681-1X
1	1710	2.114-32	3.000	6.062	EY 6-4-8751-1
					<i>High angle yoke</i>
1	1710	2.114-32	3.000	6.062	EY 6-4-8761-1X
					<i>High angle yoke</i>
1	1760	2.114-32	3.000	5.000	EY 6.3-4-1511-1
1	1760	2.114-32	3.000	5.000	EY 6.3-4-1521-1X
1	1810	2.114-32	3.000	5.000	EY 6.5-4-4451-1
1	1810	2.114-32	3.000	5.000	EY 6.5-4-4461-1X

Pos	Series	Spline Data	Hub Dia	* to End of Hub	End Fitting Part Number
J230-SB					
1	1610	2.114-32	3.000	2.844	CF 5-1-6691
					<i>.424 deep counterbore at hub end</i>
1	1610	2.114-32	3.000	2.844	CF 5-1-6701X
					<i>.424 deep counterbore at hub end</i>
1	SPL140	2.114-32	3.000	4.810	EY 140-4-921-1
1	SPL140	2.114-32	3.000	4.810	EY 140-4-931-1X
1	SPL170	2.114-32	3.000	5.000	EY 170-4-891-1
1	SPL170	2.114-32	3.000	5.000	EY 170-4-901-1X
1	SPL170	2.114-32	3.000	6.312	EY 170-4-951-1
					<i>High angle yoke</i>
1	SPL170	2.114-32	3.000	6.312	EY 170-4-961-1X
					<i>High angle yoke</i>
1	SPL250	2.114-32	3.000	5.240	EY 250-4-411-1
1	SPL250	2.114-32	3.000	5.240	EY 250-4-421-1X
1	SPL90	2.114-32	3.000	4.375	EY 90-4-581-1
1	SPL90	2.114-32	3.000	4.375	EY 90-4-591-1X
1	1480	2.114-32	3.000	4.281	EY 3-4-13341-1
1	1480	2.114-32	3.000	4.281	EY 3-4-13351-1X
1	1550	2.114-32	3.000	4.312	EY 4-4-6991-1
1	1550	2.114-32	3.000	4.312	EY 4-4-7001-1X
1	1610	2.114-32	3.000	5.375	EY 5-4-8601-1
1	1610	2.114-32	3.000	5.375	EY 5-4-8611-1X
1	1610	2.114-32	3.000	6.000	EY 5-4-8681-1
					<i>High angle yoke</i>
1	1610	2.114-32	3.000	6.000	EY 5-4-8691-1X
					<i>High angle yoke</i>
1	1710	2.114-32	3.000	4.562	EY 6-4-8671-1
1	1710	2.114-32	3.000	4.562	EY 6-4-8681-1X
1	1710	2.114-32	3.000	6.062	EY 6-4-8751-1
					<i>High angle yoke</i>
1	1710	2.114-32	3.000	6.062	EY 6-4-8761-1X
					<i>High angle yoke</i>
1	1760	2.114-32	3.000	5.000	EY 6.3-4-1511-1

Pos	Series	Spline Data	Hub Dia	* to End of Hub	End Fitting Part Number
J230-SB (Continued)					
1	1760	2.114-32	3.000	5.000	EY 6.3-4-1521-1X
1	1810	2.114-32	3.000	5.000	EY 6.5-4-4451-1
1	1810	2.114-32	3.000	5.000	EY 6.5-4-4461-1X

Pos	Series	Spline Data	Hub Dia	* to End of Hub	End Fitting Part Number
M185-T					
1	1610	1.998-38	3.000	4.844	EY 5-4-7121X

Pos	Series	Spline Data	Hub Dia	* to End of Hub	End Fitting Part Number
M190-T, M210-T					
1	SPL140	1.998-38	3.000	4.680	EY 140-4-901-1
1	SPL140	1.998-38	3.000	4.680	EY 140-4-911-1X
1	SPL90	1.998-38	3.000	4.250	EY 90-4-561-1
1	SPL90	1.998-38	3.000	4.250	EY 90-4-571-1X
1	1480	1.998-38	3.000	4.281	EY 3-4-12111-1
1	1480	1.998-38	3.000	4.281	EY 3-4-12121-1X
1	1550	1.998-38	3.000	4.500	EY 4-4-6971-1
1	1550	1.998-38	3.000	4.500	EY 4-4-6981-1X
1	1610	1.998-38	3.000	4.844	EY 5-4-8581-1
1	1610	1.998-38	3.000	4.844	EY 5-4-8591-1X
1	1710	1.998-38	3.000	4.844	EY 6-4-8651-1
1	1710	1.998-38	3.000	4.844	EY 6-4-8661-1X
1	1760	1.998-38	3.000	4.844	EY 6.3-4-1491-1
1	1760	1.998-38	3.000	4.844	EY 6.3-4-1501-1X

Pos	Series	Spline Data	Hub Dia	* to End of Hub	End Fitting Part Number
M220-T					
1	SPL140	1.998-38	3.000	4.680	EY 140-4-901-1
1	SPL140	1.998-38	3.000	4.680	EY 140-4-911-1X
1	SPL90	1.998-38	3.000	4.250	EY 90-4-561-1
1	SPL90	1.998-38	3.000	4.250	EY 90-4-571-1X
1	1480	1.998-38	3.000	4.281	EY 3-4-12111-1
1	1480	1.998-38	3.000	4.281	EY 3-4-12121-1X
1	1550	1.998-38	3.000	4.500	EY 4-4-6971-1
1	1550	1.998-38	3.000	4.500	EY 4-4-6981-1X
1	1610	1.998-38	3.000	4.844	EY 5-4-7121X
1	1610	1.998-38	3.000	4.844	EY 5-4-8581-1
1	1610	1.998-38	3.000	4.844	EY 5-4-8591-1X
1	1710	1.998-38	3.000	4.844	EY 6-4-8651-1
1	1710	1.998-38	3.000	4.844	EY 6-4-8661-1X
1	1760	1.998-38	3.000	4.844	EY 6.3-4-1491-1
1	1760	1.998-38	3.000	4.844	EY 6.3-4-1501-1X

Pos	Series	Spline Data	Hub Dia	* to End of Hub	End Fitting Part Number
M230-T					
1	SPL140	1.998-38	3.000	4.680	EY 140-4-901-1
1	SPL140	1.998-38	3.000	4.680	EY 140-4-911-1X
1	SPL90	1.998-38	3.000	4.250	EY 90-4-561-1
1	SPL90	1.998-38	3.000	4.250	EY 90-4-571-1X
1	1480	1.998-38	3.000	4.281	EY 3-4-12111-1
1	1480	1.998-38	3.000	4.281	EY 3-4-12121-1X
1	1550	1.998-38	3.000	4.500	EY 4-4-6971-1
1	1550	1.998-38	3.000	4.500	EY 4-4-6981-1X
1	1610	1.998-38	3.000	4.844	EY 5-4-8581-1
1	1610	1.998-38	3.000	4.844	EY 5-4-8591-1X
1	1710	1.998-38	3.000	4.844	EY 6-4-8651-1
1	1710	1.998-38	3.000	4.844	EY 6-4-8661-1X
1	1760	1.998-38	3.000	4.844	EY 6.3-4-1491-1
1	1760	1.998-38	3.000	4.844	EY 6.3-4-1501-1X

*C/L to End of Hub for EY (End Yoke); Flange Face to End of Hub for CF (Companion Flange)

■ Hub machined for speedometer gear



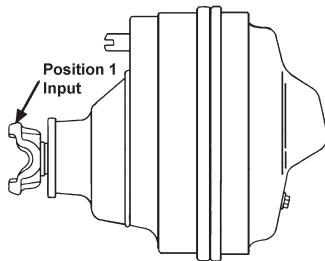

Pos	Series	Spline Data	Hub Dia	* to End of Hub	End Fitting Part Number
-----	--------	-------------	---------	-----------------	-------------------------

N175-S, N190-S, N210-S					
1	1610	2.114-32	3.000	2.844	CF 5-1-6691 <i>.424 deep counterbore at hub end</i>
1	1610	2.114-32	3.000	2.844	CF 5-1-6701X <i>.424 deep counterbore at hub end</i>
1	SPL140	2.114-32	3.000	4.810	EY 140-4-921-1
1	SPL140	2.114-32	3.000	4.810	EY 140-4-931-1X
1	SPL170	2.114-32	3.000	5.000	EY 170-4-891-1
1	SPL170	2.114-32	3.000	5.000	EY 170-4-901-1X
1	SPL170	2.114-32	3.000	6.312	EY 170-4-951-1 <i>High angle yoke</i>
1	SPL170	2.114-32	3.000	6.312	EY 170-4-961-1X <i>High angle yoke</i>
1	SPL250	2.114-32	3.000	5.240	EY 250-4-411-1
1	SPL250	2.114-32	3.000	5.240	EY 250-4-421-1X
1	SPL90	2.114-32	3.000	4.375	EY 90-4-581-1
1	SPL90	2.114-32	3.000	4.375	EY 90-4-591-1X
1	1480	2.114-32	3.000	4.281	EY 3-4-13341-1
1	1480	2.114-32	3.000	4.281	EY 3-4-13351-1X
1	1550	2.114-32	3.000	4.312	EY 4-4-6991-1
1	1550	2.114-32	3.000	4.312	EY 4-4-7001-1X
1	1610	2.114-32	3.000	5.375	EY 5-4-8601-1
1	1610	2.114-32	3.000	5.375	EY 5-4-8611-1X
1	1610	2.114-32	3.000	6.000	EY 5-4-8681-1 <i>High angle yoke</i>
1	1610	2.114-32	3.000	6.000	EY 5-4-8691-1X <i>High angle yoke</i>
1	1710	2.114-32	3.000	4.562	EY 6-4-8671-1
1	1710	2.114-32	3.000	4.562	EY 6-4-8681-1X
1	1710	2.114-32	3.000	6.062	EY 6-4-8751-1 <i>High angle yoke</i>
1	1710	2.114-32	3.000	6.062	EY 6-4-8761-1X <i>High angle yoke</i>
1	1760	2.114-32	3.000	5.000	EY 6.3-4-1511-1
1	1760	2.114-32	3.000	5.000	EY 6.3-4-1521-1X
1	1810	2.114-32	3.000	5.000	EY 6.5-4-4451-1
1	1810	2.114-32	3.000	5.000	EY 6.5-4-4461-1X

RA-29, RA-30, RA-39					
1	1610	1.750-10	2.375	4.188	EY 5-4-1481
1	1610	1.750-10	2.375	4.688	EY 5-4-1481-1

S110					
1	SPL140	2.024-39	3.000	4.470	CF 5007494
1	SPL70	2.024-39	2.875	3.375	CF 5009516 <i>w/serrated flange face & c'bore @ hub end</i>
1	SPL100	2.024-39	3.000	4.150	EY 100-4-06608-1X
1	SPL100	1.790-34	3.000	6.063	EY 100-4-07842-1 <i>Flanged end yoke.</i>
1	SPL100	2.024-39	3.000	4.150	EY 5006607
1	SPL100	2.024-39	3.000	4.150	EY 5006608
1	SPL140	2.024-39	3.000	4.470	EY 140-4-07494X
1	SPL140	2.024-39	3.000	4.470	EY 5007493
1	SPL140	2.024-39	3.000	4.470	EY 5007494

Pos	Series	Spline Data	Hub Dia	* to End of Hub	End Fitting Part Number
-----	--------	-------------	---------	-----------------	-------------------------

S110 (Continued)					
1	SPL55	2.034-39	3.000	5.438	EY 5003812
1	SPL55	2.034-39	3.000	5.438	EY 5003813
1	SPL55	2.024-39	3.000	3.875	EY 55-4-03328-1X
1	SPL55	2.034-39	3.000	5.438	EY 55-4-03813-1X
1	SPL70	2.024-39	3.000	3.878	EY 5006977
1	SPL70	2.024-39	3.000	3.878	EY 70-4-06977X
1	1480	2.024-39	3.000	3.878	EY 3-4-06976-1X
1	1480	2.024-39	3.000	3.878	EY 3-4-14781-1
1	1480	2.024-39	3.000	3.878	EY 3-4-14791-1X
1	1480	2.024-39	3.000	3.878	EY 5006976

S130					
1	SPL70	2.024-39	2.875	3.375	CF 5009516 <i>w/serrated flange face & c'bore @ hub end</i>
1	SPL100	2.024-39	3.000	4.150	EY 100-4-06608-1X
1	SPL100	1.790-34	3.000	6.063	EY 100-4-07842-1 <i>Flanged end yoke.</i>
1	SPL100	2.024-39	3.000	4.150	EY 5006607
1	SPL100	2.024-39	3.000	4.150	EY 5006608
1	SPL140	2.024-39	3.000	4.470	EY 140-4-07494X
1	SPL140	2.024-39	3.000	4.470	EY 5007493
1	SPL140	2.024-39	3.000	4.470	EY 5007494
1	SPL70	2.024-39	3.000	3.878	EY 5001782
1	SPL70	2.024-39	3.000	3.878	EY 5006977
1	SPL70	2.024-39	3.000	3.875	EY 70-4-03330-1X
1	SPL70	2.024-39	3.000	3.878	EY 70-4-06977X
1	1480	2.024-39	3.000	3.878	EY 3-4-06976-1X
1	1480	2.024-39	3.000	3.878	EY 3-4-14781-1
1	1480	2.024-39	3.000	3.878	EY 5006976

S135					
1	SPL55	1.790-34	2.375	4.219	EY 55-4-31-1
1	SPL55	1.790-34	2.375	4.219	EY 55-4-41-1X
1	SPL70	1.790-34	2.375	4.000	EY 70-4-51-1
1	SPL70	1.790-34	2.375	4.000	EY 70-4-61-1X
1	SPL90	1.790-34	2.375	5.625	EY 90-4-541-1
1	SPL90	1.790-34	2.375	5.625	EY 90-4-551-1X
1	1480	1.790-34	2.375	4.219	EY 3-4-12091-1
1	1550	1.790-34	2.375	4.000	EY 4-4-6951-1
1	1550	1.790-34	2.375	4.000	EY 4-4-6961-1X
1	1610	1.790-34	2.375	4.125	EY 5-4-8561-1
1	1610	1.790-34	2.375	4.125	EY 5-4-8571-1X

S140					
1	SPL100	2.024-39	3.000	4.750	EY 100-4-1431-1X
1	SPL100	2.024-39	3.000	6.062	EY 100-4-1451-1X <i>Counterbore at hub end.</i>
1	SPL140	2.024-39	3.000	6.250	EY 140-4-1641-1X <i>Flanged yoke w/8 tapped metric holes.</i>
1	SPL170	2.024-39	3.000	5.156	EY 170-4-1991-1X <i>High angle yoke</i>
1	1710	2.024-39	3.000	5.250	EY 6-4-10321-1X

*C/L to End of Hub for EY (End Yoke); Flange Face to End of Hub for CF (Companion Flange)

■ Hub machined for speedometer gear



Pos	Series	Spline Data	Hub Dia	* to End of Hub	End Fitting Part Number
S150					
1	SPL100	1.790-34	3.001	6.547	EY 100-4-1341-1 <i>Flanged end yoke; OEM only</i>
1	SPL100	1.790-34	3.001	6.547	EY 100-4-1351-1X <i>Flanged end yoke; OEM only</i>
1	SPL55	1.790-34	2.375	4.219	EY 55-4-31-1
1	SPL55	1.790-34	2.375	4.219	EY 55-4-41-1X
1	SPL70	1.790-34	2.375	4.000	EY 70-4-51-1
1	SPL70	1.790-34	2.375	4.000	EY 70-4-61-1X
1	SPL90	1.790-34	2.375	5.625	EY 90-4-541-1
1	SPL90	1.790-34	2.375	5.625	EY 90-4-551-1X
1	1480	1.790-34	2.375	4.219	EY 3-4-12091-1
1	1550	1.790-34	2.375	4.000	EY 4-4-6951-1
1	1550	1.790-34	2.375	4.000	EY 4-4-6961-1X
1	1610	1.790-34	2.375	4.125	EY 5-4-8561-1
1	1610	1.790-34	2.375	4.125	EY 5-4-8571-1X

Pos	Series	Spline Data	Hub Dia	* to End of Hub	End Fitting Part Number
S170					
1	1710	2.544-49	3.818	3.130	CF 131436K <i>Nut #131095 (incl. in assy) is used only on Spicer Axles; Slinger not sold separately</i>
1	1710	2.544-49	3.818	3.130	CF 5008460 <i>Nut #131095 (incl. in assy) is used only on Spicer Axles;</i>
1	SPL170	2.544-49	3.818	5.531	EY 131433K <i>Attach nut #131095 on Spicer Axle only</i>
1	SPL170	2.544-49	3.818	6.260	EY 131434K <i>Attach nut #131095 on Spicer Axle only</i>
1	SPL170	2.544-49	3.818	6.260	EY 170-4-08451-1X <i>131434K = 170-4-08451-1X & nut# 131095; Spicer axles only</i>
1	SPL170	2.544-49	3.820	5.531	EY 170-4-08458-1X <i>131433K = 170-4-08458-1X & nut# 131095; Spicer axles only</i>
1	SPL170	2.544-49	3.820	5.531	EY 170-4-2021-1X
1	SPL250	2.544-49	3.819	5.830	EY 131435K <i>Attach nut #131095 on Spicer Axle only</i>
1	SPL250	2.544-49	3.819	5.830	EY 250-4-08459-1X <i>131435K = 250-4-08459-1X & nut# 131095; Spicer axles only</i>
1	SPL250	2.544-49	3.861	5.830	EY 250-4-1301-1X
1	1710	2.544-49	3.819	5.570	EY 131437K <i>Attach nut #131095 on Spicer Axle only</i>
1	1710	2.544-49	3.819	6.260	EY 131438K <i>Attach nut #131095 on Spicer Axle only</i>
1	1710	2.544-49	3.819	6.260	EY 131439K <i>Attach nut #131095 on Spicer Axle only</i>
1	1710	2.544-49	3.819	5.570	EY 131442K <i>Attach nut #131095 on Spicer Axle only</i>
1	1710	2.544-49	3.819	6.260	EY 6-4-08449X <i>131439K = 6-4-08449X & nut# 131095; Spicer axles only</i>
1	1710	2.544-49	3.819	6.260	EY 6-4-08450-1X <i>131438K = 6-4-08450-1X & nut# 131095; Spicer axles only</i>
1	1710	2.544-49	3.819	5.570	EY 6-4-08452X <i>131442K = 6-4-08452X & nut# 131095; Spicer axles only</i>
1	1710	2.544-49	3.819	5.570	EY 6-4-08453-1X <i>131437K = 6-4-08453-1X & nut 131095; Spicer axles only</i>
1	1760	2.544-49	3.818	5.200	EY 131440K <i>Attach nut #131095 on Spicer Axle only</i>
1	1760	2.544-49	3.818	5.200	EY 131441K <i>Attach nut #131095 on Spicer Axle only</i>
1	1760	2.544-49	3.818	5.200	EY 5008454 <i>Attach nut #131095 on Spicer Axle only</i>
1	1760	2.544-49	3.818	5.200	EY 6.3-4-08454X <i>131441K = 6.3-4-08454X & nut# 131095; Spicer axles only</i>
1	1760	2.544-49	3.818	5.200	EY 6.3-4-08455-1X <i>131440K = 6.3-4-08455-1X & nut# 131095; Spicer axles only</i>
1	1760	2.544-49	3.818	5.200	EY 6.3-4-1861-1 <i>131440K = 6.3-4-08455-1X & nut# 131095; Spicer axles only</i>

Pos	Series	Spline Data	Hub Dia	* to End of Hub	End Fitting Part Number
S170 (Continued)					
1	1810	2.544-49	3.818	5.740	EY 131443K <i>Attach nut #131095 on Spicer Axle only</i>
1	1810	2.544-49	3.818	5.740	EY 131444K <i>Attach nut #131095 on Spicer Axle only</i>
1	1810	2.544-49	3.818	5.740	EY 6.5-4-08456X <i>131444K = 6.5-4-08456X & nut# 131095; Spicer axles only</i>
1	1810	2.544-49	3.818	5.740	EY 6.5-4-08457-1X <i>131443K = 6.5-4-08457-1X & nut# 131095; Spicer axles only</i>
1	1810	2.544-49	3.818	5.740	EY 6.5-4-5091 <i>131444K = 6.5-4-08456X & nut# 131095; Spicer axles only</i>
1	1810	2.544-49	3.818	5.740	EY 6.5-4-5091-1 <i>131443K = 6.5-4-08457-1X & nut# 131095; Spicer axles only</i>

Pos	Series	Spline Data	Hub Dia	* to End of Hub	End Fitting Part Number
S175					
1	SPL170	2.024-39	3.000	5.031	EY 170-4-841-1
1	SPL170	2.024-39	3.000	5.031	EY 170-4-861-1X
1	SPL250	2.024-39	3.000	5.240	EY 250-4-381-1
1	1610	2.024-39	3.000	6.000	EY 5-4-9291-1 <i>High angle yoke</i>
1	1610	2.024-39	3.000	6.000	EY 5-4-9311-1X <i>High angle yoke</i>
1	1710	2.024-39	3.000	6.000	EY 6-4-9291-1 <i>High angle yoke</i>
1	1710	2.024-39	3.000	6.000	EY 6-4-9301-1X <i>High angle yoke</i>
1	1710	2.024-39	3.000	4.656	EY 6-4-9421-1
1	1710	2.024-39	3.000	4.656	EY 6-4-9431-1X
1	1760	2.024-39	3.000	5.625	EY 6.3-4-1701-1
1	1810	2.024-39	3.000	5.000	EY 6.5-4-4651-1

Pos	Series	Spline Data	Hub Dia	* to End of Hub	End Fitting Part Number
S190					
1	1710	2.544-49	3.818	3.130	CF 131436K <i>Nut #131095 (incl. in assy) is used only on Spicer Axles; Slinger not sold separately</i>
1	1710	2.544-49	3.818	3.130	CF 5008460 <i>Nut #131095 (incl. in assy) is used only on Spicer Axles.</i>
1	SPL170	2.544-49	3.818	5.531	EY 131433K <i>Attach nut #131095 on Spicer Axle only</i>
1	SPL170	2.544-49	3.818	6.260	EY 131434K <i>Attach nut #131095 on Spicer Axle only</i>
1	SPL170	2.544-49	3.818	6.260	EY 170-4-08451-1X <i>131434K = 170-4-08451-1X & nut# 131095; Spicer axles only</i>
1	SPL170	2.544-49	3.820	5.531	EY 170-4-08458-1X <i>131433K = 170-4-08458-1X & nut# 131095; Spicer axles only</i>
1	SPL170	2.544-49	3.820	5.531	EY 170-4-1891-1
1	SPL170	2.544-49	3.820	5.531	EY 170-4-2021-1X
1	SPL170	2.024-39	3.000	5.031	EY 170-4-841-1
1	SPL170	2.024-39	3.000	5.031	EY 170-4-861-1X
1	SPL250	2.544-49	3.819	5.830	EY 131435K <i>Attach nut #131095 on Spicer Axle only</i>
1	SPL250	2.544-49	3.819	5.830	EY 250-4-08459-1X <i>131435K = 250-4-08459-1X & nut# 131095; Spicer axles only</i>
1	SPL250	2.544-49	3.861	5.830	EY 250-4-1301-1X
1	SPL250	2.024-39	3.000	5.240	EY 250-4-381-1
1	1610	2.024-39	3.000	6.000	EY 5-4-9291-1 <i>High angle yoke</i>
1	1610	2.024-39	3.000	6.000	EY 5-4-9311-1X <i>High angle yoke</i>
1	1710	2.544-49	3.819	5.570	EY 131437K <i>Attach nut #131095 on Spicer Axle only</i>
1	1710	2.544-49	3.819	6.260	EY 131438K <i>Attach nut #131095 on Spicer Axle only</i>
1	1710	2.544-49	3.819	6.260	EY 131439K <i>Attach nut #131095 on Spicer Axle only</i>

Continued on next page

*C/L to End of Hub for EY (End Yoke); Flange Face to End of Hub for CF (Companion Flange)

■ Hub machined for speedometer gear



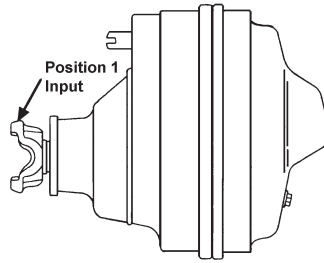

Pos	Series	Spline Data	Hub Dia	* to End of Hub	End Fitting Part Number
-----	--------	-------------	---------	-----------------	-------------------------

S190 (Continued)

1	1710	2.544-49	3.819	5.570	EY 131442K <i>Attach nut #131095 on Spicer Axle only</i>
1	1710	2.544-49	3.819	6.260	EY 6-4-08450-1X <i>131438K = 6-4-08450-1X & nut# 131095; Spicer axles only</i>
1	1710	2.544-49	3.819	5.570	EY 6-4-08452X <i>131442K = 6-4-08452X & nut# 131095; Spicer axles only</i>
1	1710	2.544-49	3.819	5.570	EY 6-4-08453-1X <i>131437K = 6-4-08453-1X & nut 131095; Spicer axles only</i>
1	1710	2.544-49	3.819	5.570	EY 6-4-10291 <i>131442K = 6-4-08452X & nut# 131095; Spicer axles only</i>
1	1710	2.544-49	3.819	5.570	EY 6-4-10291-1 <i>131437K = 6-4-08453-1X & nut 131095; Spicer axles only</i>
1	1710	2.544-49	3.819	6.260	EY 6-4-10311 <i>131439K = 6-4-08449X & nut# 131095; Spicer axles only</i>
1	1710	2.544-49	3.819	6.260	EY 6-4-10311-1 <i>131438K = 6-4-08450-1X & nut# 131095; Spicer axles only</i>
1	1710	2.024-39	3.000	6.000	EY 6-4-9291-1 <i>High angle yoke</i>
1	1710	2.024-39	3.000	6.000	EY 6-4-9301-1X <i>High angle yoke</i>
1	1710	2.024-39	3.000	4.656	EY 6-4-9421-1
1	1710	2.024-39	3.000	4.656	EY 6-4-9431-1X
1	1760	2.544-49	3.818	5.200	EY 131440K <i>Attach nut #131095 on Spicer Axle only</i>
1	1760	2.544-49	3.818	5.200	EY 131441K <i>Attach nut #131095 on Spicer Axle only</i>
1	1760	2.544-49	3.818	5.200	EY 6.3-4-08454X <i>131441K = 6.3-4-08454X & nut# 131095; Spicer axles only</i>
1	1760	2.544-49	3.818	5.200	EY 6.3-4-08455-1X <i>131440K = 6.3-4-08455-1X & nut# 131095; Spicer axles only</i>
1	1760	2.024-39	3.000	5.625	EY 6.3-4-1701-1
1	1760	2.544-49	3.818	5.200	EY 6.3-4-1861-1 <i>131440K = 6.3-4-08455-1X & nut# 131095; Spicer axles only</i>
1	1810	2.544-49	3.818	5.740	EY 131443K <i>Attach nut #131095 on Spicer Axle only</i>
1	1810	2.544-49	3.818	5.740	EY 131444K <i>Attach nut #131095 on Spicer Axle only</i>
1	1810	2.544-49	3.818	5.740	EY 6.5-4-08456X <i>131444K = 6.5-4-08456X & nut# 131095; Spicer axles only</i>
1	1810	2.544-49	3.818	5.740	EY 6.5-4-08457-1X <i>131443K = 6.5-4-08457-1X & nut# 131095; Spicer axles only</i>
1	1810	2.024-39	3.000	5.000	EY 6.5-4-4651-1
1	1810	2.544-49	3.818	5.740	EY 6.5-4-5091 <i>131444K = 6.5-4-08456X & nut# 131095; Spicer axles only</i>
1	1810	2.544-49	3.818	5.740	EY 6.5-4-5091-1 <i>131443K = 6.5-4-08457-1X & nut# 131095; Spicer axles only</i>

S210

1	SPL170	2.024-39	3.000	5.031	EY 170-4-841-1
1	SPL170	2.024-39	3.000	5.031	EY 170-4-861-1X
1	SPL250	2.024-39	3.000	5.240	EY 250-4-381-1
1	1610	2.024-39	3.000	6.000	EY 5-4-9291-1 <i>High angle yoke</i>
1	1610	2.024-39	3.000	6.000	EY 5-4-9311-1X <i>High angle yoke</i>

Pos	Series	Spline Data	Hub Dia	* to End of Hub	End Fitting Part Number
-----	--------	-------------	---------	-----------------	-------------------------

S210 (Continued)

1	1710	2.024-39	3.000	6.000	EY 6-4-9291-1 <i>High angle yoke</i>
1	1710	2.024-39	3.000	6.000	EY 6-4-9301-1X <i>High angle yoke</i>
1	1710	2.024-39	3.000	4.656	EY 6-4-9421-1
1	1710	2.024-39	3.000	4.656	EY 6-4-9431-1X
1	1760	2.024-39	3.000	5.625	EY 6.3-4-1701-1
1	1810	2.024-39	3.000	5.000	EY 6.5-4-4651-1

S220

1	SPL170	2.024-39	3.000	5.031	EY 170-4-841-1
1	SPL170	2.024-39	3.000	5.031	EY 170-4-861-1X
1	SPL250	2.024-39	3.000	5.240	EY 250-4-381-1
1	1610	2.024-39	3.000	6.000	EY 5-4-9291-1 <i>High angle yoke</i>
1	1610	2.024-39	3.000	6.000	EY 5-4-9311-1X <i>High angle yoke</i>
1	1710	2.024-39	3.000	6.000	EY 6-4-9291-1 <i>High angle yoke</i>
1	1710	2.024-39	3.000	6.000	EY 6-4-9301-1X <i>High angle yoke</i>
1	1710	2.024-39	3.000	4.656	EY 6-4-9421-1
1	1710	2.024-39	3.000	4.656	EY 6-4-9431-1X
1	1760	2.024-39	3.000	5.625	EY 6.3-4-1701-1
1	1810	2.024-39	3.000	5.000	EY 6.5-4-4651-1

S230-S, S300-S

1	SPL170	2.364-36	3.500	5.270	EY 170-4-1031-1
1	SPL170	2.364-36	3.500	5.270	EY 170-4-1041-1X
1	1710	2.364-36	3.500	5.234	EY 6-4-8791-1
1	1710	2.364-36	3.500	5.234	EY 6-4-8801-1X
1	1760	2.364-36	3.500	5.230	EY 6.3-4-1601-1
1	1760	2.364-36	3.500	5.230	EY 6.3-4-1611-1X
1	1810	2.364-36	3.500	5.230	EY 6.5-4-4471-1
1	1810	2.364-36	3.500	5.230	EY 6.5-4-4481-1X

S400

1	SPL170	2.024-39	3.000	5.031	EY 170-4-841-1
1	SPL170	2.024-39	3.000	5.031	EY 170-4-861-1X
1	SPL250	2.024-39	3.000	5.240	EY 250-4-381-1
1	1610	2.024-39	3.000	6.000	EY 5-4-9291-1 <i>High angle yoke</i>
1	1610	2.024-39	3.000	6.000	EY 5-4-9311-1X <i>High angle yoke</i>
1	1710	2.024-39	3.000	6.000	EY 6-4-9291-1 <i>High angle yoke</i>
1	1710	2.024-39	3.000	6.000	EY 6-4-9301-1X <i>High angle yoke</i>
1	1710	2.024-39	3.000	4.656	EY 6-4-9421-1
1	1710	2.024-39	3.000	4.656	EY 6-4-9431-1X
1	1760	2.024-39	3.000	5.625	EY 6.3-4-1701-1
1	1810	2.024-39	3.000	5.000	EY 6.5-4-4651-1

*C/L to End of Hub for EY (End Yoke); Flange Face to End of Hub for CF (Companion Flange)

■ Hub machined for speedometer gear



Pos	Series	Spline Data	Hub Dia	* to End of Hub	End Fitting Part Number
S590					
1	SPL170	2.544-49	3.820	6.040	EY 132863K <i>Attach nut #131095 on Spicer Axle only</i>
1	SPL170	2.544-49	3.820	6.812	EY 132931K <i>Attach nut #131095 on Spicer Axle only</i>
1	SPL170	2.544-49	3.820	6.040	EY 170-4-08444-1X <i>132863K = 170-4-08444-1X & nut# 131095; Spicer axles only</i>
1	SPL170	2.544-49	3.820	6.810	EY 170-4-08461-1X <i>132931K = 170-4-08461-1X & nut# 131095; Spicer axles only</i>
1	SPL250	2.544-49	3.819	6.200	EY 131446K <i>Attach nut #131095 on Spicer Axle only</i>
1	SPL250	2.544-49	3.819	6.200	EY 250-4-08445-1X <i>131446K = 250-4-08445-1X & nut# 131095; Spicer axles only</i>
1	1710	2.544-49	3.819	6.050	EY 131519K <i>Attach nut #131095 on Spicer Axle only</i>
1	1710	2.544-49	3.819	6.050	EY 131530K <i>Attach nut #131095 on Spicer Axle only</i>
1	1710	2.544-49	3.819	6.050	EY 6-4-08438X <i>131530K = 6-4-08438X & nut# 131095; Spicer axles only</i>
1	1760	2.544-49	3.819	6.050	EY 131520K <i>Attach nut #131095 on Spicer Axle only</i>
1	1810	2.544-49	3.820	5.740	EY 131447K <i>Attach nut #131095 on Spicer Axle only</i>
1	1810	2.544-49	3.819	5.740	EY 131448K <i>Attach nut #131095 on Spicer Axle only</i>
1	1810	2.544-49	3.819	5.740	EY 6.5-4-08442X <i>131448K = 6.5-4-08442X & nut# 131095; Spicer axles only</i>
1	1810	2.544-49	3.820	5.740	EY 6.5-4-08443-1X <i>131447K = 6.5-4-08443-1X & nut# 131095; Spicer axles only</i>
T170, T190					
1	SPL170	2.544-49	3.820	6.810	EY 170-4-08461-1X <i>132931K = 170-4-08461-1X & nut# 131095; Spicer axles only</i>
W190-S, W190-T, W210-T, W220-S, W220-T					
1	1710	1.998-38	3.000	4.840	EY 6-4-9951-1
W230-S					
1	SPL170	2.364-36	3.000	5.470	EY 170-4-1011-1
1	SPL170	2.364-36	3.000	5.470	EY 170-4-1021-1X
1	SPL90	2.364-36	3.000	4.812	EY 90-4-601-1
1	SPL90	2.364-36	3.000	4.812	EY 90-4-611-1X
1	1550	2.364-36	3.000	5.078	EY 4-4-7011-1
1	1550	2.364-36	3.000	5.078	EY 4-4-7111-1X
1	1610	2.364-36	3.000	5.156	EY 5-4-8621-1
1	1610	2.364-36	3.000	5.156	EY 5-4-8631-1X
1	1710	2.364-36	3.000	5.438	EY 6-4-5711
1	1710	2.364-36	3.000	5.438	EY 6-4-8691-1
1	1710	2.364-36	3.000	5.438	EY 6-4-8701-1X
1	1760	2.364-36	3.000	5.438	EY 6.3-4-1531-1
1	1760	2.364-36	3.000	5.438	EY 6.3-4-1541-1X
1	1810	2.364-36	3.000	5.438	EY 6.5-4-3161
1	1810	2.364-36	3.000	5.438	EY 6.5-4-3651X
1	1810	2.364-36	3.000	5.438	EY 6.5-4-4411-1
1	1810	2.364-36	3.000	5.438	EY 6.5-4-4421-1X
28					
1	1310	1.026-23	1.552	3.000	EY 2-4-6131-1X
30					
1	1280/1310	1.146-26	1.554	2.594	CF 2-1-1881X
1	1310	1.146-26	1.552	3.406	EY 2-4-5251X <i>Spec. yoke w/1.125 dia. brg. caps</i>
1	1310	1.146-26	1.552	3.000	EY 2-4-8091-1X
1	1310	1.146-26	1.552	3.000	EY 2-4-8091X
1	1330	1.146-26	1.552	3.000	EY 2-4-3581-1X
1	1330	1.146-26	1.562	3.000	EY 2-4-6111X

Pos	Series	Spline Data	Hub Dia	* to End of Hub	End Fitting Part Number
35-FRONT					
1	1310	1.146-26	1.844	2.938	EY 2-4-6901-1X
35-REAR					
1	1310	1.146-26	1.844	2.938	EY 2-4-4601-1
1	1330	1.146-26	1.844	3.562	EY 2-4-7631-1 <i>High angle yoke</i>
1	7260	1.146-26	1.844	3.219	EY 2-4-7661-1
36					
1	1310	1.146-26	1.552	3.000	EY 2-4-8091-1X
44, 50					
1	1280/1310	1.146-26	1.554	2.594	CF 2-1-1881X
1	1310	1.146-26	1.552	3.406	EY 2-4-5251X <i>Spec. yoke w/1.125 dia. brg. caps</i>
1	1310	1.146-26	1.552	3.000	EY 2-4-8091-1X
1	1310	1.146-26	1.552	3.000	EY 2-4-8091X
1	1330	1.146-26	1.552	3.000	EY 2-4-3581-1X
1	1330	1.146-26	1.562	3.000	EY 2-4-6111X
60					
1	1350/1410	1.276-29	1.875	2.062	CF 3-1-4041X
1	1310	1.276-29	1.875	2.938	EY 2-4-3801-1X
1	1310	1.276-29	1.875	2.938	EY 2-4-3801X
1	1330	1.276-29	1.875	2.938	EY 2-4-4291-1X
1	1330	1.276-29	1.875	2.938	EY 2-4-5311X
1	1330	1.276-29	1.875	2.938	EY 2-4-8051X
1	1350	1.276-29	1.875	3.000	EY 3-4-5731-1X
1	1410	1.276-29	1.875	3.188	EY 3-4-5711-1X
1	7290	1.276-29	1.875	3.359	EY 2-4-7681-1X
61					
1	1350/1410	1.276-29	1.875	2.062	CF 3-1-4041X
1	1310	1.276-29	1.875	2.938	EY 2-4-3801-1X
1	1310	1.276-29	1.875	2.938	EY 2-4-3801X
1	1330	1.276-29	1.875	2.938	EY 2-4-4291-1X
1	1330	1.276-29	1.875	2.938	EY 2-4-5311X
1	1330	1.276-29	1.875	2.938	EY 2-4-8051X
1	1350	1.276-29	1.875	3.000	EY 3-4-5731-1X
1	1410	1.276-29	1.875	3.188	EY 3-4-5711-1X
70					
1	1350/1410	1.276-29	1.875	2.062	CF 3-1-4041X
1	1310	1.276-29	1.875	2.938	EY 2-4-3801-1X
1	1310	1.276-29	1.875	2.938	EY 2-4-3801X
1	1330	1.276-29	1.875	2.938	EY 2-4-4291-1X
1	1330	1.276-29	1.875	2.938	EY 2-4-5311X
1	1330	1.276-29	1.875	2.938	EY 2-4-8051X
1	1350	1.276-29	1.875	3.200	EY 3-4-14711-1X <i>Attaching hardware by OEM</i>
1	1350	1.276-29	1.875	3.000	EY 3-4-5731-1X
1	1410	1.276-29	1.875	3.188	EY 3-4-5711-1X
80					
1	1410	1.609-37	2.500	4.312	EY 3-4-11081-1X
1	1410	1.276-29	1.875	3.188	EY 5003491
1	1480	1.609-37	2.500	4.328	EY 3-4-11281-1X
1	1480	1.609-37	2.500	4.328	EY 3-4-14731-1X
1	1550	1.609-37	2.500	4.406	EY 4-4-6851-1X
300-S					
1	1810	2.364-36	3.500	5.230	EY 6.5-4-4471-1
1	1810	2.364-36	3.500	5.230	EY 6.5-4-4481-1X

*C/L to End of Hub for EY (End Yoke); Flange Face to End of Hub for CF (Companion Flange)

■ Hub machined for speedometer gear



Important: See Safety Information in General Information Section (J300P-GI)

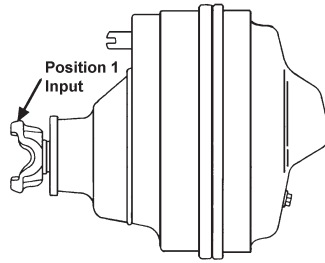

Pos	Series	Spline Data	Hub Dia	* to End of Hub	End Fitting Part Number
2501					
1	1610	2.149-16	2.938	6.250	EY 5-4-5161-1X
1	1610	2.149-16	2.938	6.250	EY 5-4-5161X <i>High angle yoke</i>
1	1710	2.149-16	2.938	5.500	EY 6-4-4171-1X
1	1710	2.149-16	2.938	5.500	EY 6-4-4171X
1	1760	2.149-16	2.938	5.812	EY 6.3-4-251-1X
1	1760	2.149-16	2.938	5.812	EY 6.3-4-251X
1	1810	2.149-16	2.938	5.812	EY 6.5-4-2291
1	1810	2.149-16	2.938	5.812	EY 6.5-4-2291-1
1	1810	2.149-16	2.938	5.812	EY 6.5-4-2401-1X
1	1810	2.149-16	2.938	5.812	EY 6.5-4-2401X

13101					
1	1480	1.500-10	2.250	4.200	EY 3-4-3781-1
1	1480	1.500-10	2.250	4.200	EY 3-4-6221-1X

15040-P					
1	SPL140	1.790-34	2.625	4.870	EY 140-4-461-1
1	1410	1.790-34	2.625	4.031	EY 3-4-10251-1
1	1480	1.790-34	2.625	4.281	EY 3-4-10261-1
1	1480	1.790-34	2.625	4.281	EY 3-4-11921-1X
1	1550	1.790-34	2.625	4.275	EY 4-4-5551-1
1	1610	1.790-34	2.625	4.750	EY 5-4-7261-1
1	1610	1.790-34	2.625	4.750	EY 5-4-7301-1X
1	1710	1.790-34	2.625	5.438	EY 6-4-7571-1
1	1710	1.790-34	2.625	5.438	EY 6-4-7581-1X

15040-S, 15040-T					
1	SPL140	1.790-34	2.625	4.870	EY 140-4-461-1
1	SPL140	1.790-34	2.625	4.870	EY 140-4-471-1X
1	SPL140	1.790-34	2.625	4.870	EY 140-4-481-1X
1	1410	1.790-34	2.625	4.031	EY 3-4-10251-1
1	1410	1.790-34	2.625	4.031	EY 3-4-10461-1X
1	1480	1.790-34	2.625	4.281	EY 3-4-10261-1
1	1480	1.790-34	2.625	4.281	EY 3-4-10471-1X
1	1480	1.790-34	2.625	4.281	EY 3-4-11921-1X
1	1550	1.790-34	2.625	4.275	EY 4-4-5551-1
1	1550	1.790-34	2.625	4.275	EY 4-4-5611-1X
1	1610	1.790-34	2.625	4.750	EY 5-4-7261-1
1	1610	1.790-34	2.625	4.750	EY 5-4-7301-1X
1	1710	1.790-34	2.625	5.438	EY 6-4-7571-1
1	1710	1.790-34	2.625	5.438	EY 6-4-7581-1X

15101, 15201, 15301					
1	1480	1.500-10	2.250	4.200	EY 3-4-3781-1
1	1480	1.500-10	2.250	4.200	EY 3-4-6221-1X

16121					
1	1550	1.750-10	2.625	4.672	EY 4-4-3581-1X <i>All ratios except 4.33.; .250 deep spline chamfer</i>
1	1610	1.962-10	2.625	6.000	EY 5-4-4771X <i>W/4.33 ratio.; High angle yoke</i>

Pos	Series	Spline Data	Hub Dia	* to End of Hub	End Fitting Part Number
16121 (Continued)					
1	1610	1.750-10	2.625	4.750	EY 5-4-5111-1X <i>All ratios except 4.33.</i>
1	1610	1.750-10	2.625	4.750	EY 5-4-5111X <i>All ratios except 4.33.</i>
1	1610	1.962-10	2.625	4.719	EY 5-4-5121X <i>W/4.33 ratio.</i>
1	1710	1.750-10	2.625	5.250	EY 6-4-4301X <i>All ratios except 4.33.; Chamfered Counterbore</i>
1	1710	1.962-10	2.625	6.125	EY 6-4-4851X <i>W/4.33 ratio.; Chamfered Counterbore; High angle yoke</i>
1	1710	1.750-10	2.625	6.125	EY 6-4-4861X <i>All ratios except 4.33.; Chamfered Counterbore; High angle yoke</i>
1	1710	1.962-10	2.625	5.250	EY 6-4-5151X <i>W/4.33 ratio.; Chamfered Counterbore</i>

16130, 16930					
1	SPL140	1.790-34	2.625	4.870	EY 140-4-461-1
1	SPL140	1.790-34	2.625	4.870	EY 140-4-471-1X
1	1410	1.790-34	2.625	4.031	EY 3-4-10251-1
1	1410	1.790-34	2.625	4.031	EY 3-4-10461-1X
1	1480	1.790-34	2.625	4.281	EY 3-4-10261-1
1	1480	1.790-34	2.625	4.281	EY 3-4-10471-1X
1	1550	1.790-34	2.625	4.275	EY 4-4-5551-1
1	1550	1.790-34	2.625	4.275	EY 4-4-5611-1X
1	1610	1.790-34	2.625	4.750	EY 5-4-7261-1
1	1610	1.790-34	2.625	4.750	EY 5-4-7301-1X
1	1710	1.790-34	2.625	5.438	EY 6-4-7571-1
1	1710	1.790-34	2.625	5.438	EY 6-4-7581-1X

17060-A, 17060-S					
1	SPL170	2.024-39	3.000	5.156	EY 170-4-261-1X
1	SPL170	2.024-39	3.000	6.240	EY 170-4-281-1X <i>High angle yoke</i>
1	SPL90	2.024-39	3.000	4.750	EY 90-4-251-1X
1	1480	2.024-39	3.000	4.344	EY 3-4-13081-1X
1	1550	2.024-39	3.000	4.281	EY 4-4-7571-1X
1	1610	2.024-39	3.000	6.000	EY 5-4-9241-1X <i>High angle yoke</i>
1	1610	2.024-39	3.000	6.000	EY 5-4-9241X <i>High angle yoke</i>
1	1710	2.024-39	3.000	6.125	EY 6-4-8991X <i>High angle yoke</i>
1	1710	2.024-39	3.000	5.250	EY 6-4-9031-1X
1	1710	2.024-39	3.000	5.250	EY 6-4-9031X

17060-D					
1	SPL170	2.024-39	3.000	5.156	EY 170-4-261-1X
1	SPL170	2.024-39	3.000	6.240	EY 170-4-281-1X <i>High angle yoke</i>
1	SPL90	2.024-39	3.000	4.750	EY 90-4-251-1X
1	1480	2.024-39	3.000	4.344	EY 3-4-13081-1X
1	1550	2.024-39	3.000	4.281	EY 4-4-7571-1X
1	1610	2.024-39	3.000	4.875	EY 5-4-9231-1X

*C/L to End of Hub for EY (End Yoke); Flange Face to End of Hub for CF (Companion Flange)

■ Hub machined for speedometer gear



Pos	Series	Spline Data	Hub Dia	* to End of Hub	End Fitting Part Number
17060-D, 17060-S (Continued)					
1	1610	2.024-39	3.000	6.000	EY 5-4-9241-1X <i>High angle yoke</i>
1	1610	2.024-39	3.000	6.000	EY 5-4-9241X <i>High angle yoke</i>
1	1710	2.024-39	3.000	6.125	EY 6-4-8991X <i>High angle yoke</i>
1	1710	2.024-39	3.000	5.250	EY 6-4-9031-1X
1	1710	2.024-39	3.000	5.250	EY 6-4-9031X

17101					
1	1550	1.750-10	2.625	4.672	EY 4-4-3581-1X .250 deep spline chamfer
1	1610	1.750-10	2.625	4.750	EY 5-4-5111-1X
1	1610	1.750-10	2.625	4.750	EY 5-4-5111X
1	1710	1.750-10	2.625	5.250	EY 6-4-4301X <i>Chamfered Counterbore</i>
1	1710	1.750-10	2.625	6.125	EY 6-4-4861X <i>Chamfered Counterbore; High angle yoke</i>

17121					
1	1550	1.750-10	2.625	4.672	EY 4-4-3581-1X .250 deep spline chamfer
1	1610	1.750-10	2.625	4.750	EY 5-4-2081
1	1610	1.962-10	2.625	6.000	EY 5-4-4771X <i>High angle yoke</i>
1	1610	1.750-10	2.625	4.750	EY 5-4-5111-1X
1	1610	1.750-10	2.625	4.750	EY 5-4-5111X
1	1610	1.962-10	2.625	4.719	EY 5-4-5121X
1	1710	1.750-10	2.625	5.250	EY 6-4-4301X <i>Chamfered Counterbore</i>
1	1710	1.962-10	2.625	6.125	EY 6-4-4851X <i>Chamfered Counterbore High angle yoke</i>
1	1710	1.750-10	2.625	6.125	EY 6-4-4861X <i>Chamfered Counterbore; High angle yoke</i>
1	1710	1.962-10	2.625	5.250	EY 6-4-5151X <i>Chamfered Counterbore</i>

17130					
1	SPL170	2.024-39	2.625	4.938	EY 170-4-161-1X
1	SPL170	2.024-39	2.625	6.016	EY 170-4-181-1X <i>High angle yoke</i>
1	1550	2.024-39	2.625	4.266	EY 4-4-7551-1X
1	1610	2.024-39	2.625	6.000	EY 5-4-8421X <i>High angle yoke</i>
1	1710	2.024-39	2.625	4.719	EY 5-4-8131-1X
1	1710	2.024-39	2.625	5.312	EY 5-4-8411X
1	1710	2.024-39	2.625	5.250	EY 6-4-8531X
1	1710	2.024-39	2.625	6.125	EY 6-4-8541X <i>High angle yoke</i>

17430					
1	SPL170	2.024-39	2.625	4.938	EY 170-4-161-1X
1	SPL170	2.024-39	2.625	6.016	EY 170-4-181-1X <i>High angle yoke</i>
1	1550	2.024-39	2.625	4.266	EY 4-4-7551-1X
1	1610	2.024-39	2.625	4.719	EY 5-4-8131-1X
1	1610	2.024-39	2.625	5.312	EY 5-4-8411X
1	1610	2.024-39	2.625	6.000	EY 5-4-8421X <i>High angle yoke</i>
1	1710	2.024-39	2.625	5.250	EY 6-4-8531X
1	1710	2.024-39	2.625	6.125	EY 6-4-8541X <i>High angle yoke</i>

Pos	Series	Spline Data	Hub Dia	* to End of Hub	End Fitting Part Number
18121					
1	1550	1.750-10	2.625	4.672	EY 4-4-3581-1X .250 deep spline chamfer
1	1610	1.750-10	2.625	4.750	EY 5-4-2081
1	1610	1.962-10	2.625	6.000	EY 5-4-4771X <i>High angle yoke</i>
1	1610	1.750-10	2.625	4.750	EY 5-4-5111-1X
1	1610	1.750-10	2.625	4.750	EY 5-4-5111X
1	1610	1.962-10	2.625	4.719	EY 5-4-5121X
1	1710	1.750-10	2.625	5.250	EY 6-4-4301X <i>Chamfered Counterbore</i>
1	1710	1.962-10	2.625	6.125	EY 6-4-4851X <i>Chamfered Counterbore; High angle yoke</i>
1	1710	1.750-10	2.625	6.125	EY 6-4-4861X <i>Chamfered Counterbore; High angle yoke</i>
1	1710	1.962-10	2.625	5.250	EY 6-4-5151X <i>Chamfered Counterbore</i>

19050-A					
1	SPL140	1.790-34	2.625	4.870	EY 140-4-461-1
1	SPL140	1.790-34	2.625	4.870	EY 140-4-471-1X
1	1410	1.790-34	2.625	4.031	EY 3-4-10251-1
1	1410	1.790-34	2.625	4.031	EY 3-4-10461-1X
1	1480	1.790-34	2.625	4.281	EY 3-4-10261-1
1	1480	1.790-34	2.625	4.281	EY 3-4-10471-1X
1	1550	1.790-34	2.625	4.275	EY 4-4-5551-1
1	1550	1.790-34	2.625	4.275	EY 4-4-5611-1X
1	1610	1.790-34	2.625	4.750	EY 5-4-7261-1
1	1610	1.790-34	2.625	4.750	EY 5-4-7301-1X
1	1710	1.790-34	2.625	5.438	EY 6-4-7571-1
1	1710	1.790-34	2.625	5.438	EY 6-4-7581-1X

19050-D					
1	1410	1.790-34	2.625	4.031	EY 3-4-10461-1X
1	1480	1.790-34	2.625	4.281	EY 3-4-10471-1X
1	1550	1.790-34	2.625	4.275	EY 4-4-5611-1X
1	1610	1.790-34	2.625	4.750	EY 5-4-7301-1X
1	1710	1.790-34	2.625	5.438	EY 6-4-7581-1X

19050-P					
1	SPL140	1.790-34	2.625	4.870	EY 140-4-461-1
1	SPL140	1.790-34	2.625	4.870	EY 140-4-471-1X
1	1410	1.790-34	2.625	4.031	EY 3-4-10251-1
1	1410	1.790-34	2.625	4.031	EY 3-4-10461-1X
1	1480	1.790-34	2.625	4.281	EY 3-4-10261-1
1	1480	1.790-34	2.625	4.281	EY 3-4-10471-1X
1	1550	1.790-34	2.625	4.275	EY 4-4-5551-1
1	1550	1.790-34	2.625	4.275	EY 4-4-5611-1X
1	1610	1.790-34	2.625	4.750	EY 5-4-7261-1
1	1610	1.790-34	2.625	4.750	EY 5-4-7301-1X
1	1710	1.790-34	2.625	5.438	EY 6-4-7571-1
1	1710	1.790-34	2.625	5.438	EY 6-4-7581-1X

19050-S					
1	SPL140	1.790-34	2.625	4.870	EY 140-4-461-1
1	SPL140	1.790-34	2.625	4.870	EY 140-4-471-1X
1	1410	1.790-34	2.625	4.031	EY 3-4-10251-1
1	1410	1.790-34	2.625	4.031	EY 3-4-10461-1X
1	1480	1.790-34	2.625	4.281	EY 3-4-10261-1
1	1480	1.790-34	2.625	4.281	EY 3-4-10471-1X
1	1550	1.790-34	2.625	4.275	EY 4-4-5551-1
1	1550	1.790-34	2.625	4.275	EY 4-4-5611-1X

Continued on next page

*C/L to End of Hub for EY (End Yoke); Flange Face to End of Hub for CF (Companion Flange)

■ Hub machined for speedometer gear



Important: See Safety Information in General Information Section (J300P-GI)

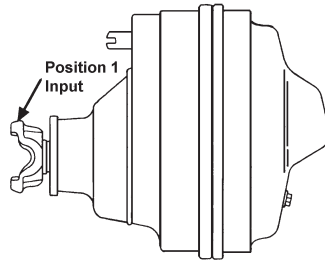

Pos	Series	Spline Data	Hub Dia	* to End of Hub	End Fitting Part Number
-----	--------	-------------	---------	-----------------	-------------------------

19050-S (Continued)

1	1610	1.790-34	2.625	4.750	EY 5-4-7261-1
1	1610	1.790-34	2.625	4.750	EY 5-4-7301-1X
1	1610	2.024-39	3.000	4.875	EY 5-4-9231-1X
1	1710	1.790-34	2.625	5.438	EY 6-4-7571-1
1	1710	1.790-34	2.625	5.438	EY 6-4-7581-1X

19050-T

1	SPL140	1.790-34	2.625	4.870	EY 140-4-461-1
1	SPL140	1.790-34	2.625	4.870	EY 140-4-471-1X
1	1410	1.790-34	2.625	4.031	EY 3-4-10251-1
1	1410	1.790-34	2.625	4.031	EY 3-4-10461-1X
1	1480	1.790-34	2.625	4.281	EY 3-4-10261-1
1	1480	1.790-34	2.625	4.281	EY 3-4-10471-1X
1	1550	1.790-34	2.625	4.275	EY 4-4-5551-1
1	1550	1.790-34	2.625	4.275	EY 4-4-5611-1X
1	1610	1.790-34	2.625	4.750	EY 5-4-7261-1
1	1610	1.790-34	2.625	4.750	EY 5-4-7301-1X
1	1710	1.790-34	2.625	5.438	EY 6-4-7571-1
1	1710	1.790-34	2.625	5.438	EY 6-4-7581-1X

19055-D, 19055-P, 19055-S

1	SPL140	2.024-39	2.625	4.940	EY 140-4-491-1
1	SPL140	2.024-39	2.625	4.940	EY 140-4-501-1X
1	SPL170	2.024-39	2.625	4.938	EY 170-4-161-1X
1	SPL170	2.024-39	2.625	6.016	EY 170-4-181-1X <i>High angle yoke</i>
1	SPL90	2.024-39	2.626	4.160	EY 90-4-621-1
1	SPL90	2.024-39	2.626	4.160	EY 90-4-631-1X
1	1480	2.024-39	2.625	4.344	EY 3-4-11051-1
1	1480	2.024-39	2.625	4.344	EY 3-4-11061-1X
1	1550	2.024-39	2.625	4.281	EY 4-4-5621-1
1	1550	2.024-39	2.625	4.281	EY 4-4-5691-1X
1	1550	2.024-39	2.625	4.266	EY 4-4-7551-1X
1	1610	2.024-39	2.625	4.719	EY 5-4-7981-1
1	1610	2.024-39	2.625	4.719	EY 5-4-8131-1X
1	1610	2.024-39	2.625	5.312	EY 5-4-8411X
1	1610	2.024-39	2.625	6.000	EY 5-4-8421X <i>High angle yoke</i>
1	1710	2.024-39	2.625	5.250	EY 6-4-8531X
1	1710	2.024-39	2.625	6.125	EY 6-4-8541X <i>High angle yoke</i>

19055-T

1	SPL100	2.024-39	2.625	7.295	EY 100-4-1321-1 <i>Flanged yoke w/8 tapped holes in flange</i>
1	SPL100	2.024-39	2.625	7.295	EY 100-4-1331-1X <i>Flanged yoke w/8 tapped holes in flange</i>
1	SPL140	2.024-39	2.768	7.587	EY 140-4-1611-1X <i>Flanged yoke w/8 tapped holes in flange</i>
1	SPL140	2.024-39	2.625	4.940	EY 140-4-491-1
1	SPL140	2.024-39	2.625	4.940	EY 140-4-501-1X
1	SPL170	2.024-39	2.625	4.938	EY 170-4-161-1X

Pos	Series	Spline Data	Hub Dia	* to End of Hub	End Fitting Part Number
-----	--------	-------------	---------	-----------------	-------------------------

19055-T (Continued)

1	SPL170	2.024-39	2.625	6.016	EY 170-4-181-1X <i>High angle yoke</i>
1	SPL90	2.024-39	2.626	4.160	EY 90-4-621-1
1	SPL90	2.024-39	2.626	4.160	EY 90-4-631-1X
1	1480	2.024-39	2.625	4.344	EY 3-4-11051-1
1	1480	2.024-39	2.625	4.344	EY 3-4-11061-1X
1	1550	2.024-39	2.625	4.281	EY 4-4-5621-1
1	1550	2.024-39	2.625	4.281	EY 4-4-5691-1X
1	1550	2.024-39	2.625	4.266	EY 4-4-7551-1X
1	1610	2.024-39	2.625	4.719	EY 5-4-7981-1
1	1610	2.024-39	2.625	4.719	EY 5-4-8131-1X
1	1610	2.024-39	2.625	5.312	EY 5-4-8411X
1	1610	2.024-39	2.625	6.000	EY 5-4-8421X <i>High angle yoke</i>
1	1710	2.024-39	2.625	5.250	EY 6-4-8531X
1	1710	2.024-39	2.625	6.125	EY 6-4-8541X <i>High angle yoke</i>

19060-A, 19060-D

1	SPL100	2.024-39	3.000	4.750	EY 100-4-951-1
1	SPL100	2.024-39	3.000	4.750	EY 100-4-961-1X
1	SPL140	2.024-39	3.000	4.940	EY 140-4-1151-1
1	SPL140	2.024-39	3.000	4.940	EY 140-4-1161-1X
1	SPL140	2.024-39	3.000	4.940	EY 140-4-361-1
1	SPL140	2.024-39	3.000	4.940	EY 140-4-371-1X
1	SPL170	2.024-39	3.000	5.156	EY 170-4-251-1 <i>High angle yoke</i>
1	SPL170	2.024-39	3.000	5.156	EY 170-4-261-1X
1	SPL170	2.024-39	3.000	6.240	EY 170-4-271-1 <i>High angle yoke</i>
1	SPL170	2.024-39	3.000	6.240	EY 170-4-281-1X <i>High angle yoke</i>
1	SPL55	2.024-39	3.000	4.330	EY 55-4-71-1
1	SPL55	2.024-39	3.000	4.330	EY 55-4-81-1X
1	SPL70	2.024-39	3.000	4.281	EY 70-4-101-1
1	SPL70	2.024-39	3.000	4.281	EY 70-4-111-1X
1	SPL90	2.024-39	3.000	4.750	EY 90-4-241-1
1	SPL90	2.024-39	3.000	4.750	EY 90-4-251-1X
1	1480	2.024-39	3.000	4.344	EY 3-4-13071-1
1	1480	2.024-39	3.000	4.344	EY 3-4-13081-1X
1	1550	2.024-39	3.000	4.281	EY 4-4-7561-1
1	1550	2.024-39	3.000	4.281	EY 4-4-7571-1X
1	1610	2.024-39	3.000	6.000	EY 5-4-8261 <i>High angle yoke</i>
1	1610	2.024-39	3.000	6.000	EY 5-4-8261-1 <i>High angle yoke</i>
1	1610	2.024-39	3.000	4.875	EY 5-4-9221-1
1	1610	2.024-39	3.000	4.875	EY 5-4-9231-1X
1	1610	2.024-39	3.000	6.000	EY 5-4-9241-1X <i>High angle yoke</i>
1	1610	2.024-39	3.000	6.000	EY 5-4-9241X <i>High angle yoke</i>

*C/L to End of Hub for EY (End Yoke); Flange Face to End of Hub for CF (Companion Flange)

■ Hub machined for speedometer gear



Pos	Series	Spline Data	Hub Dia	* to End of Hub	End Fitting Part Number
19060-A, 19060-D (Continued)					
1	1710	2.024-39	3.000	6.125	EY 6-4-8411 <i>High angle yoke</i>
1	1710	2.024-39	3.000	6.125	EY 6-4-8411-1 <i>High angle yoke</i>
1	1710	2.024-39	3.000	5.250	EY 6-4-8421
1	1710	2.024-39	3.000	5.250	EY 6-4-8421-1
1	1710	2.024-39	3.000	6.125	EY 6-4-8991-1X <i>High angle yoke</i>
1	1710	2.024-39	3.000	6.125	EY 6-4-8991X <i>High angle yoke</i>
1	1710	2.024-39	3.000	5.250	EY 6-4-9031-1X
1	1710	2.024-39	3.000	5.250	EY 6-4-9031X

19060-P					
1	SPL100	2.024-39	2.625	4.160	EY 100-4-1071-1
1	SPL100	2.024-39	2.625	4.160	EY 100-4-1081-1X
1	SPL140	2.024-39	2.625	5.030	EY 140-4-551-1 <i>Counterbore at hub end.</i>
1	SPL140	2.024-39	2.625	5.030	EY 140-4-561-1X <i>Counterbore at hub end.</i>
1	SPL170	2.024-39	2.625	4.938	EY 170-4-151-1
1	SPL170	2.024-39	2.625	4.938	EY 170-4-161-1X
1	SPL170	2.024-39	2.625	6.016	EY 170-4-171-1 <i>High angle yoke</i>
1	SPL170	2.024-39	2.625	6.016	EY 170-4-181-1X <i>High angle yoke</i>
1	SPL70	2.024-39	3.000	4.281	EY 70-4-101-1
1	SPL70	2.024-39	3.000	4.281	EY 70-4-111-1X
1	1480	2.024-39	2.625	4.344	EY 3-4-13051-1
1	1480	2.024-39	2.625	4.344	EY 3-4-13061-1X
1	1550	2.024-39	2.625	4.266	EY 4-4-6471-1
1	1550	2.024-39	2.625	4.266	EY 4-4-7551-1X
1	1610	2.024-39	2.625	5.312	EY 5-4-7971
1	1610	2.024-39	2.625	5.312	EY 5-4-7971-1
1	1610	2.024-39	2.625	6.000	EY 5-4-7991 <i>High angle yoke</i>
1	1610	2.024-39	2.625	4.719	EY 5-4-8131-1X
1	1610	2.024-39	2.625	5.312	EY 5-4-8411-1X
1	1610	2.024-39	2.625	5.312	EY 5-4-8411X
1	1610	2.024-39	2.625	6.000	EY 5-4-8421X <i>High angle yoke</i>
1	1710	2.024-39	2.625	6.125	EY 6-4-7981 <i>High angle yoke</i>
1	1710	2.024-39	2.625	6.125	EY 6-4-7981-1 <i>High angle yoke</i>
1	1710	2.024-39	2.625	5.250	EY 6-4-7991
1	1710	2.024-39	2.625	5.250	EY 6-4-7991-1
1	1710	2.024-39	2.625	5.250	EY 6-4-8531-1X
1	1710	2.024-39	2.625	5.250	EY 6-4-8531X
1	1710	2.024-39	2.625	6.125	EY 6-4-8541-1X <i>High angle yoke</i>
1	1710	2.024-39	2.625	6.125	EY 6-4-8541X <i>High angle yoke</i>

19060-S					
1	SPL100	2.024-39	3.000	4.750	EY 100-4-951-1
1	SPL100	2.024-39	3.000	4.750	EY 100-4-961-1X
1	SPL140	2.024-39	3.000	4.940	EY 140-4-1151-1
1	SPL140	2.024-39	3.000	4.940	EY 140-4-1161-1X
1	SPL140	2.024-39	3.000	4.940	EY 140-4-361-1
1	SPL140	2.024-39	3.000	4.940	EY 140-4-371-1X
1	SPL170	2.024-39	3.000	5.156	EY 170-4-251-1 <i>High angle yoke</i>

Pos	Series	Spline Data	Hub Dia	* to End of Hub	End Fitting Part Number
19060-S (Continued)					
1	SPL170	2.024-39	3.000	5.156	EY 170-4-261-1X
1	SPL170	2.024-39	3.000	6.240	EY 170-4-271-1 <i>High angle yoke</i>
1	SPL170	2.024-39	3.000	6.240	EY 170-4-281-1X <i>High angle yoke</i>
1	SPL55	2.024-39	3.000	4.330	EY 55-4-71-1
1	SPL55	2.024-39	3.000	4.330	EY 55-4-81-1X
1	SPL70	2.024-39	3.000	4.281	EY 70-4-101-1
1	SPL70	2.024-39	3.000	4.281	EY 70-4-111-1X
1	SPL90	2.024-39	3.000	4.750	EY 90-4-241-1
1	SPL90	2.024-39	3.000	4.750	EY 90-4-251-1X
1	1480	2.024-39	3.000	4.344	EY 3-4-13071-1
1	1480	2.024-39	3.000	4.344	EY 3-4-13081-1X
1	1550	2.024-39	3.000	4.281	EY 4-4-7561-1
1	1550	2.024-39	3.000	4.281	EY 4-4-7571-1X
1	1610	2.024-39	3.000	6.000	EY 5-4-8261 <i>High angle yoke</i>
1	1610	2.024-39	3.000	6.000	EY 5-4-8261-1 <i>High angle yoke</i>
1	1610	2.024-39	3.000	4.875	EY 5-4-9221-1
1	1610	2.024-39	3.000	4.875	EY 5-4-9231-1X
1	1610	2.024-39	3.000	6.000	EY 5-4-9241-1X <i>High angle yoke</i>
1	1610	2.024-39	3.000	6.000	EY 5-4-9241X <i>High angle yoke</i>
1	1710	2.024-39	3.000	6.125	EY 6-4-8411 <i>High angle yoke</i>
1	1710	2.024-39	3.000	6.125	EY 6-4-8411-1 <i>High angle yoke</i>
1	1710	2.024-39	3.000	5.250	EY 6-4-8421
1	1710	2.024-39	3.000	5.250	EY 6-4-8421-1
1	1710	2.024-39	3.000	6.125	EY 6-4-8991-1X <i>High angle yoke</i>
1	1710	2.024-39	3.000	6.125	EY 6-4-8991X <i>High angle yoke</i>
1	1710	2.024-39	3.000	5.250	EY 6-4-9031-1X
1	1710	2.024-39	3.000	5.250	EY 6-4-9031X

19060-T					
1	SPL100	2.024-39	2.625	4.160	EY 100-4-1071-1
1	SPL100	2.024-39	2.625	4.160	EY 100-4-1081-1X
1	SPL140	2.024-39	2.625	5.030	EY 140-4-551-1 <i>Counterbore at hub end.</i>
1	SPL140	2.024-39	2.625	5.030	EY 140-4-561-1X <i>Counterbore at hub end.</i>
1	SPL170	2.024-39	2.625	4.938	EY 170-4-161-1X
1	SPL70	2.024-39	3.000	4.281	EY 70-4-101-1
1	SPL70	2.024-39	3.000	4.281	EY 70-4-111-1X
1	1480	2.024-39	2.625	4.344	EY 3-4-13051-1
1	1480	2.024-39	2.625	4.344	EY 3-4-13061-1X
1	1550	2.024-39	2.625	4.266	EY 4-4-6471-1
1	1550	2.024-39	2.625	4.266	EY 4-4-7551-1X
1	1610	2.024-39	2.625	5.312	EY 5-4-7971
1	1610	2.024-39	2.625	5.312	EY 5-4-7971-1
1	1610	2.024-39	2.625	6.000	EY 5-4-7991 <i>High angle yoke</i>
1	1610	2.024-39	2.625	4.719	EY 5-4-8131-1X
1	1610	2.024-39	2.625	5.312	EY 5-4-8411-1X
1	1610	2.024-39	2.625	5.312	EY 5-4-8411X
1	1610	2.024-39	2.625	6.000	EY 5-4-8421X <i>High angle yoke</i>

Continued on next page

*C/L to End of Hub for EY (End Yoke); Flange Face to End of Hub for CF (Companion Flange)

■ Hub machined for speedometer gear



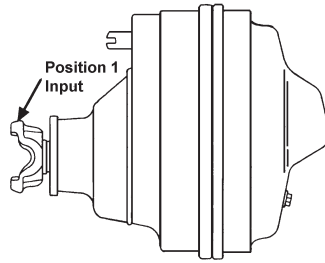

Pos	Series	Spline Data	Hub Dia	* to End of Hub	End Fitting Part Number
-----	--------	-------------	---------	-----------------	-------------------------

19060-T (Continued)

1	1710	2.024-39	2.625	6.125	EY 6-4-7981 <i>High angle yoke</i>
1	1710	2.024-39	2.625	6.125	EY 6-4-7981-1 <i>High angle yoke</i>
1	1710	2.024-39	2.625	5.250	EY 6-4-7991
1	1710	2.024-39	2.625	5.250	EY 6-4-7991-1
1	1710	2.024-39	2.625	5.250	EY 6-4-8531-1X
1	1710	2.024-39	2.625	5.250	EY 6-4-8531X
1	1710	2.024-39	2.625	6.125	EY 6-4-8541-1X <i>High angle yoke</i>
1	1710	2.024-39	2.625	6.125	EY 6-4-8541X <i>High angle yoke</i>

19100-1

1	1610	1.962-10	2.625	5.312	EY 5-4-6361-1X
1	1710	1.962-10	2.625	4.500	EY 6-4-4731-1X <i>Chamfered Counterbore</i>
1	1710	1.962-10	2.625	4.500	EY 6-4-4731X <i>Chamfered Counterbore</i>

19120-1

1	1610	2.149-16	2.938	6.250	EY 5-4-5161-1X
1	1610	2.149-16	2.938	6.250	EY 5-4-5161X <i>High angle yoke</i>
1	1710	2.149-16	2.938	5.500	EY 6-4-4171-1X
1	1710	2.149-16	2.938	5.500	EY 6-4-4171X
1	1760	2.149-16	2.938	5.812	EY 6.3-4-141
1	1760	2.149-16	2.938	5.812	EY 6.3-4-141-1
1	1760	2.149-16	2.938	5.812	EY 6.3-4-251-1X
1	1760	2.149-16	2.938	5.812	EY 6.3-4-251X
1	1810	2.149-16	2.938	5.812	EY 6.5-4-2401-1X
1	1810	2.149-16	2.938	5.812	EY 6.5-4-2401X

19121

1	1610	2.149-16	2.938	6.250	EY 5-4-5161-1X
1	1610	2.149-16	2.938	6.250	EY 5-4-5161X <i>High angle yoke</i>
1	1710	2.149-16	2.938	5.500	EY 6-4-2181
1	1710	2.149-16	2.938	5.500	EY 6-4-4171-1X
1	1710	2.149-16	2.938	5.500	EY 6-4-4171X
1	1760	2.149-16	2.938	5.812	EY 6.3-4-251-1X
1	1760	2.149-16	2.938	5.812	EY 6.3-4-251X
1	1810	2.422-18	3.375	5.812	EY 6.5-4-1991
1	1810	2.422-18	3.375	5.812	EY 6.5-4-1991-1
1	1810	2.149-16	2.938	5.812	EY 6.5-4-2401-1X
1	1810	2.149-16	2.938	5.812	EY 6.5-4-2401X

19200-1

1	1610	1.962-10	2.625	5.312	EY 5-4-6361-1X
1	1710	1.962-10	2.625	4.500	EY 6-4-4731-1X <i>Chamfered Counterbore</i>
1	1710	1.962-10	2.625	4.500	EY 6-4-4731X <i>Chamfered Counterbore</i>

Pos	Series	Spline Data	Hub Dia	* to End of Hub	End Fitting Part Number
-----	--------	-------------	---------	-----------------	-------------------------

19220-1

1	1610	2.149-16	2.938	6.250	EY 5-4-5161-1X
1	1610	2.149-16	2.938	6.250	EY 5-4-5161X <i>High angle yoke</i>
1	1710	2.149-16	2.938	5.500	EY 6-4-4171-1X
1	1710	2.149-16	2.938	5.500	EY 6-4-4171X
1	1760	2.149-16	2.938	5.812	EY 6.3-4-141
1	1760	2.149-16	2.938	5.812	EY 6.3-4-141-1
1	1760	2.149-16	2.938	5.812	EY 6.3-4-251-1X
1	1760	2.149-16	2.938	5.812	EY 6.3-4-251X
1	1810	2.149-16	2.938	5.812	EY 6.5-4-2291
1	1810	2.149-16	2.938	5.812	EY 6.5-4-2291-1
1	1810	2.149-16	2.938	5.812	EY 6.5-4-2401-1X
1	1810	2.149-16	2.938	5.812	EY 6.5-4-2401X

19221

1	1610	2.149-16	2.938	6.250	EY 5-4-5161-1X
1	1610	2.149-16	2.938	6.250	EY 5-4-5161X <i>High angle yoke</i>
1	1710	2.149-16	2.938	5.500	EY 6-4-2181
1	1710	2.149-16	2.938	5.500	EY 6-4-4171-1X
1	1710	2.149-16	2.938	5.500	EY 6-4-4171X
1	1760	2.149-16	2.938	5.812	EY 6.3-4-251-1X
1	1760	2.149-16	2.938	5.812	EY 6.3-4-251X
1	1810	2.149-16	2.938	5.812	EY 6.5-4-2401-1X
1	1810	2.149-16	2.938	5.812	EY 6.5-4-2401X

19300-1

1	1610	1.962-10	2.625	5.312	EY 5-4-6361-1X
1	1710	1.962-10	2.625	4.500	EY 6-4-4731-1X <i>Chamfered Counterbore</i>
1	1710	1.962-10	2.625	4.500	EY 6-4-4731X <i>Chamfered Counterbore</i>

19320-1

1	1610	2.149-16	2.938	6.250	EY 5-4-5161-1X
1	1610	2.149-16	2.938	6.250	EY 5-4-5161X <i>High angle yoke</i>
1	1710	2.149-16	2.938	5.500	EY 6-4-4171-1X
1	1710	2.149-16	2.938	5.500	EY 6-4-4171X
1	1760	2.149-16	2.938	5.812	EY 6.3-4-141
1	1760	2.149-16	2.938	5.812	EY 6.3-4-141-1
1	1760	2.149-16	2.938	5.812	EY 6.3-4-251-1X
1	1760	2.149-16	2.938	5.812	EY 6.3-4-251X
1	1810	2.149-16	2.938	5.812	EY 6.5-4-2291
1	1810	2.149-16	2.938	5.812	EY 6.5-4-2291-1
1	1810	2.149-16	2.938	5.812	EY 6.5-4-2401-1X
1	1810	2.149-16	2.938	5.812	EY 6.5-4-2401X

19321

1	1710	2.149-16	2.938	5.500	EY 6-4-2181
---	------	----------	-------	-------	-------------

*C/L to End of Hub for EY (End Yoke); Flange Face to End of Hub for CF (Companion Flange)

■ Hub machined for speedometer gear



Pos	Series	Spline Data	Hub Dia	* to End of Hub	End Fitting Part Number
19420-1, 19426					
1	1610	2.149-16	2.938	6.250	EY 5-4-5161-1X
1	1610	2.149-16	2.938	6.250	EY 5-4-5161X <i>High angle yoke</i>
1	1710	2.149-16	2.938	5.500	EY 6-4-4171-1X
1	1710	2.149-16	2.938	5.500	EY 6-4-4171X
1	1760	2.149-16	2.938	5.812	EY 6.3-4-141
1	1760	2.149-16	2.938	5.812	EY 6.3-4-141-1
1	1760	2.149-16	2.938	5.812	EY 6.3-4-251-1X
1	1760	2.149-16	2.938	5.812	EY 6.3-4-251X
1	1810	2.149-16	2.938	5.812	EY 6.5-4-2401-1X
1	1810	2.149-16	2.938	5.812	EY 6.5-4-2401X

20100					
1	1610	1.962-10	2.625	5.312	EY 5-4-6361-1X
1	1710	1.962-10	2.625	4.500	EY 6-4-4731-1X <i>Chamfered Counterbore</i>
1	1710	1.962-10	2.625	4.500	EY 6-4-4731X <i>Chamfered Counterbore</i>

20120-1					
1	1610	2.149-16	2.938	6.250	EY 5-4-5161-1X
1	1610	2.149-16	2.938	6.250	EY 5-4-5161X <i>High angle yoke</i>
1	1710	2.149-16	2.938	5.500	EY 6-4-4171-1X
1	1710	2.149-16	2.938	5.500	EY 6-4-4171X
1	1760	2.149-16	2.938	5.812	EY 6.3-4-141
1	1760	2.149-16	2.938	5.812	EY 6.3-4-141-1
1	1760	2.149-16	2.938	5.812	EY 6.3-4-251-1X
1	1760	2.149-16	2.938	5.812	EY 6.3-4-251X
1	1810	2.149-16	2.938	5.812	EY 6.5-4-2401-1X
1	1810	2.149-16	2.938	5.812	EY 6.5-4-2401X

20200					
1	1610	1.962-10	2.625	5.312	EY 5-4-6361-1X
1	1710	1.962-10	2.625	4.500	EY 6-4-4731-1X <i>Chamfered Counterbore</i>
1	1710	1.962-10	2.625	4.500	EY 6-4-4731X <i>Chamfered Counterbore</i>

20220					
1	1610	2.149-16	2.938	6.250	EY 5-4-5161-1X
1	1610	2.149-16	2.938	6.250	EY 5-4-5161X <i>High angle yoke</i>
1	1710	2.149-16	2.938	5.500	EY 6-4-4171-1X
1	1710	2.149-16	2.938	5.500	EY 6-4-4171X
1	1760	2.149-16	2.938	5.812	EY 6.3-4-141
1	1760	2.149-16	2.938	5.812	EY 6.3-4-141-1
1	1760	2.149-16	2.938	5.812	EY 6.3-4-251-1X
1	1760	2.149-16	2.938	5.812	EY 6.3-4-251X
1	1810	2.149-16	2.938	5.812	EY 6.5-4-2291
1	1810	2.149-16	2.938	5.812	EY 6.5-4-2291-1
1	1810	2.149-16	2.938	5.812	EY 6.5-4-2401-1X
1	1810	2.149-16	2.938	5.812	EY 6.5-4-2401X

20300					
1	1610	1.962-10	2.625	5.312	EY 5-4-6361-1X
1	1710	1.962-10	2.625	4.500	EY 6-4-4731-1X <i>Chamfered Counterbore</i>
1	1710	1.962-10	2.625	4.500	EY 6-4-4731X <i>Chamfered Counterbore</i>

Pos	Series	Spline Data	Hub Dia	* to End of Hub	End Fitting Part Number
20320					
1	1610	2.149-16	2.938	6.250	EY 5-4-5161-1X
1	1610	2.149-16	2.938	6.250	EY 5-4-5161X <i>High angle yoke</i>
1	1710	2.149-16	2.938	5.500	EY 6-4-4171-1X
1	1710	2.149-16	2.938	5.500	EY 6-4-4171X
1	1760	2.149-16	2.938	5.812	EY 6.3-4-141
1	1760	2.149-16	2.938	5.812	EY 6.3-4-141-1
1	1760	2.149-16	2.938	5.812	EY 6.3-4-251-1X
1	1760	2.149-16	2.938	5.812	EY 6.3-4-251X
1	1810	2.149-16	2.938	5.812	EY 6.5-4-2291
1	1810	2.149-16	2.938	5.812	EY 6.5-4-2291-1
1	1810	2.149-16	2.938	5.812	EY 6.5-4-2401-1X
1	1810	2.149-16	2.938	5.812	EY 6.5-4-2401X

21060-A, 21060-D					
1	SPL100	2.024-39	3.000	4.750	EY 100-4-951-1
1	SPL100	2.024-39	3.000	4.750	EY 100-4-961-1X
1	SPL140	2.024-39	3.000	4.940	EY 140-4-1151-1
1	SPL140	2.024-39	3.000	4.940	EY 140-4-1161-1X
1	SPL140	2.024-39	3.000	4.940	EY 140-4-361-1
1	SPL140	2.024-39	3.000	4.940	EY 140-4-371-1X
1	SPL170	2.024-39	3.000	5.156	EY 170-4-251-1 <i>High angle yoke</i>
1	SPL170	2.024-39	3.000	5.156	EY 170-4-261-1X
1	SPL170	2.024-39	3.000	6.240	EY 170-4-271-1 <i>High angle yoke</i>
1	SPL170	2.024-39	3.000	6.240	EY 170-4-281-1X <i>High angle yoke</i>
1	SPL55	2.024-39	3.000	4.330	EY 55-4-71-1
1	SPL55	2.024-39	3.000	4.330	EY 55-4-81-1X
1	SPL70	2.024-39	3.000	4.281	EY 70-4-101-1
1	SPL70	2.024-39	3.000	4.281	EY 70-4-111-1X
1	SPL90	2.024-39	3.000	4.750	EY 90-4-241-1
1	SPL90	2.024-39	3.000	4.750	EY 90-4-251-1X
1	1480	2.024-39	3.000	4.344	EY 3-4-13071-1
1	1480	2.024-39	3.000	4.344	EY 3-4-13081-1X
1	1550	2.024-39	3.000	4.281	EY 4-4-7561-1
1	1550	2.024-39	3.000	4.281	EY 4-4-7571-1X
1	1610	2.024-39	3.000	6.000	EY 5-4-8261 <i>High angle yoke</i>
1	1610	2.024-39	3.000	6.000	EY 5-4-8261-1 <i>High angle yoke</i>
1	1610	2.024-39	3.000	4.875	EY 5-4-9221-1
1	1610	2.024-39	3.000	4.875	EY 5-4-9231-1X
1	1610	2.024-39	3.000	6.000	EY 5-4-9241-1X <i>High angle yoke</i>
1	1610	2.024-39	3.000	6.000	EY 5-4-9241X <i>High angle yoke</i>
1	1710	2.024-39	3.000	6.125	EY 6-4-8411 <i>High angle yoke</i>
1	1710	2.024-39	3.000	6.125	EY 6-4-8411-1 <i>High angle yoke</i>
1	1710	2.024-39	3.000	5.250	EY 6-4-8421
1	1710	2.024-39	3.000	5.250	EY 6-4-8421-1
1	1710	2.024-39	3.000	6.125	EY 6-4-8991-1X <i>High angle yoke</i>
1	1710	2.024-39	3.000	6.125	EY 6-4-8991X <i>High angle yoke</i>
1	1710	2.024-39	3.000	5.250	EY 6-4-9031-1X
1	1710	2.024-39	3.000	5.250	EY 6-4-9031X

*C/L to End of Hub for EY (End Yoke); Flange Face to End of Hub for CF (Companion Flange)

■ Hub machined for speedometer gear



Important: See Safety Information in General Information Section (J300P-GI)

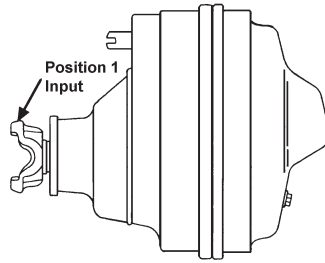

Pos	Series	Spline Data	Hub Dia	* to End of Hub	End Fitting Part Number
-----	--------	-------------	---------	-----------------	-------------------------

21060-P					
1	SPL100	2.024-39	2.625	4.160	EY 100-4-1071-1
1	SPL100	2.024-39	2.625	4.160	EY 100-4-1081-1X
1	SPL140	2.024-39	2.625	5.030	EY 140-4-551-1 <i>Counterbore at hub end.</i>
1	SPL140	2.024-39	2.625	5.030	EY 140-4-561-1X <i>Counterbore at hub end.</i>
1	SPL170	2.024-39	2.625	4.938	EY 170-4-151-1
1	SPL170	2.024-39	2.625	4.938	EY 170-4-161-1X
1	SPL170	2.024-39	2.625	6.016	EY 170-4-171-1 <i>High angle yoke</i>
1	SPL170	2.024-39	2.625	6.016	EY 170-4-181-1X <i>High angle yoke</i>
1	SPL70	2.024-39	3.000	4.281	EY 70-4-101-1
1	SPL70	2.024-39	3.000	4.281	EY 70-4-111-1X
1	1480	2.024-39	2.625	4.344	EY 3-4-13051-1
1	1480	2.024-39	2.625	4.344	EY 3-4-13061-1X
1	1550	2.024-39	2.625	4.266	EY 4-4-6471-1
1	1550	2.024-39	2.625	4.266	EY 4-4-7551-1X
1	1610	2.024-39	2.625	5.312	EY 5-4-7971
1	1610	2.024-39	2.625	5.312	EY 5-4-7971-1
1	1610	2.024-39	2.625	6.000	EY 5-4-7991 <i>High angle yoke</i>
1	1610	2.024-39	2.625	4.719	EY 5-4-8131-1X
1	1610	2.024-39	2.625	5.312	EY 5-4-8411-1X
1	1610	2.024-39	2.625	5.312	EY 5-4-8411X
1	1610	2.024-39	2.625	6.000	EY 5-4-8421X <i>High angle yoke</i>
1	1710	2.024-39	2.625	6.125	EY 6-4-7981 <i>High angle yoke</i>
1	1710	2.024-39	2.625	6.125	EY 6-4-7981-1 <i>High angle yoke</i>
1	1710	2.024-39	2.625	5.250	EY 6-4-7991
1	1710	2.024-39	2.625	5.250	EY 6-4-7991-1
1	1710	2.024-39	2.625	5.250	EY 6-4-8531-1X
1	1710	2.024-39	2.625	5.250	EY 6-4-8531X
1	1710	2.024-39	2.625	6.125	EY 6-4-8541-1X <i>High angle yoke</i>
1	1710	2.024-39	2.625	6.125	EY 6-4-8541X <i>High angle yoke</i>

21060-S					
1	SPL100	2.024-39	3.000	4.750	EY 100-4-951-1
1	SPL100	2.024-39	3.000	4.750	EY 100-4-961-1X
1	SPL140	2.024-39	3.000	4.940	EY 140-4-361-1
1	SPL140	2.024-39	3.000	4.940	EY 140-4-371-1X
1	SPL170	2.024-39	3.000	5.156	EY 170-4-251-1 <i>High angle yoke</i>
1	SPL170	2.024-39	3.000	5.156	EY 170-4-261-1X
1	SPL170	2.024-39	3.000	6.240	EY 170-4-271-1 <i>High angle yoke</i>
1	SPL170	2.024-39	3.000	6.240	EY 170-4-281-1X <i>High angle yoke</i>

Pos	Series	Spline Data	Hub Dia	* to End of Hub	End Fitting Part Number
-----	--------	-------------	---------	-----------------	-------------------------

21060-S (Continued)					
1	SPL55	2.024-39	3.000	4.330	EY 55-4-71-1
1	SPL55	2.024-39	3.000	4.330	EY 55-4-81-1X
1	SPL70	2.024-39	3.000	4.281	EY 70-4-101-1
1	SPL70	2.024-39	3.000	4.281	EY 70-4-111-1X
1	SPL90	2.024-39	3.000	4.750	EY 90-4-241-1
1	SPL90	2.024-39	3.000	4.750	EY 90-4-251-1X
1	1480	2.024-39	3.000	4.344	EY 3-4-13071-1
1	1480	2.024-39	3.000	4.344	EY 3-4-13081-1X
1	1550	2.024-39	3.000	4.281	EY 4-4-7561-1
1	1550	2.024-39	3.000	4.281	EY 4-4-7571-1X
1	1610	2.024-39	3.000	6.000	EY 5-4-8261 <i>High angle yoke</i>
1	1610	2.024-39	3.000	6.000	EY 5-4-8261-1 <i>High angle yoke</i>
1	1610	2.024-39	3.000	4.875	EY 5-4-9221-1
1	1610	2.024-39	3.000	4.875	EY 5-4-9231-1X
1	1610	2.024-39	3.000	6.000	EY 5-4-9241-1X <i>High angle yoke</i>
1	1610	2.024-39	3.000	6.000	EY 5-4-9241X <i>High angle yoke</i>
1	1710	2.024-39	3.000	6.125	EY 6-4-8411 <i>High angle yoke</i>
1	1710	2.024-39	3.000	6.125	EY 6-4-8411-1 <i>High angle yoke</i>
1	1710	2.024-39	3.000	5.250	EY 6-4-8421-1
1	1710	2.024-39	3.000	6.125	EY 6-4-8991-1X <i>High angle yoke</i>
1	1710	2.024-39	3.000	6.125	EY 6-4-8991X <i>High angle yoke</i>
1	1710	2.024-39	3.000	5.250	EY 6-4-9031-1X
1	1710	2.024-39	3.000	5.250	EY 6-4-9031X

21060-T					
1	SPL100	2.024-39	2.625	4.160	EY 100-4-1071-1
1	SPL100	2.024-39	2.625	4.160	EY 100-4-1081-1X
1	SPL140	2.024-39	2.625	5.030	EY 140-4-551-1 <i>Counterbore at hub end.</i>
1	SPL140	2.024-39	2.625	5.030	EY 140-4-561-1X <i>Counterbore at hub end.</i>
1	SPL170	2.024-39	2.625	4.938	EY 170-4-151-1
1	SPL170	2.024-39	2.625	4.938	EY 170-4-161-1X
1	SPL70	2.024-39	3.000	4.281	EY 70-4-101-1
1	SPL70	2.024-39	3.000	4.281	EY 70-4-111-1X
1	SPL90	2.024-39	2.626	4.160	EY 5005379
1	SPL90	2.024-39	2.626	4.160	EY 90-4-05379-1X
1	SPL90	2.024-39	2.626	4.160	EY 90-4-621-1
1	1480	2.024-39	2.625	4.344	EY 3-4-13051-1
1	1480	2.024-39	2.625	4.344	EY 3-4-13061-1X
1	1550	2.024-39	2.625	4.266	EY 4-4-6471-1
1	1550	2.024-39	2.625	4.266	EY 4-4-7551-1X
1	1610	2.024-39	2.625	5.312	EY 5-4-7971

*C/L to End of Hub for EY (End Yoke); Flange Face to End of Hub for CF (Companion Flange)

■ Hub machined for speedometer gear



Pos	Series	Spline Data	Hub Dia	* to End of Hub	End Fitting Part Number
21060-T (Continued)					
1	1610	2.024-39	2.625	5.312	EY 5-4-7971-1
1	1610	2.024-39	2.625	6.000	EY 5-4-7991 <i>High angle yoke</i>
1	1610	2.024-39	2.625	4.719	EY 5-4-8131-1X
1	1610	2.024-39	2.625	5.312	EY 5-4-8411-1X
1	1610	2.024-39	2.625	5.312	EY 5-4-8411X
1	1610	2.024-39	2.625	6.000	EY 5-4-8421X <i>High angle yoke</i>
1	1710	2.024-39	2.625	6.125	EY 6-4-7981 <i>High angle yoke</i>
1	1710	2.024-39	2.625	6.125	EY 6-4-7981-1 <i>High angle yoke</i>
1	1710	2.024-39	2.625	5.250	EY 6-4-7991
1	1710	2.024-39	2.625	5.250	EY 6-4-7991-1
1	1710	2.024-39	2.625	5.250	EY 6-4-8531-1X
1	1710	2.024-39	2.625	5.250	EY 6-4-8531X
1	1710	2.024-39	2.625	6.125	EY 6-4-8541-1X <i>High angle yoke</i>
1	1710	2.024-39	2.625	6.125	EY 6-4-8541X <i>High angle yoke</i>

Pos	Series	Spline Data	Hub Dia	* to End of Hub	End Fitting Part Number
21065-D, 21065-P					
1	SPL140	2.024-39	2.625	4.940	EY 140-4-491-1
1	SPL140	2.024-39	2.625	4.940	EY 140-4-501-1X
1	SPL170	2.024-39	2.625	4.938	EY 170-4-161-1X
1	SPL170	2.024-39	2.625	6.016	EY 170-4-181-1X <i>High angle yoke</i>
1	SPL90	2.024-39	2.626	4.160	EY 90-4-621-1
1	SPL90	2.024-39	2.626	4.160	EY 90-4-631-1X
1	1480	2.024-39	2.625	4.344	EY 3-4-11051-1
1	1480	2.024-39	2.625	4.344	EY 3-4-11061-1X
1	1550	2.024-39	2.625	4.281	EY 4-4-5621-1
1	1550	2.024-39	2.625	4.281	EY 4-4-5691-1X
1	1550	2.024-39	2.625	4.266	EY 4-4-7551-1X
1	1610	2.024-39	2.625	4.719	EY 5-4-7981-1
1	1610	2.024-39	2.625	4.719	EY 5-4-8131-1X
1	1610	2.024-39	2.625	5.312	EY 5-4-8411X
1	1610	2.024-39	2.625	6.000	EY 5-4-8421X <i>High angle yoke</i>
1	1710	2.024-39	2.625	5.250	EY 6-4-8531X
1	1710	2.024-39	2.625	6.125	EY 6-4-8541X <i>High angle yoke</i>

Pos	Series	Spline Data	Hub Dia	* to End of Hub	End Fitting Part Number
21065-S, 21065-T					
1	SPL100	2.024-39	2.625	7.295	EY 100-4-1321-1 <i>Flanged yoke w/8 tapped holes in flange</i>
1	SPL100	2.024-39	2.625	7.295	EY 100-4-1331-1X <i>Flanged yoke w/8 tapped holes in flange</i>
1	SPL140	2.024-39	2.768	7.587	EY 140-4-1601-1 <i>Flanged yoke w/8 tapped holes in flange</i>
1	SPL140	2.024-39	2.768	7.587	EY 140-4-1611-1X <i>Flanged yoke w/8 tapped holes in flange</i>
1	SPL140	2.024-39	2.625	4.940	EY 140-4-491-1
1	SPL140	2.024-39	2.625	4.940	EY 140-4-501-1X
1	SPL170	2.024-39	2.625	4.938	EY 170-4-161-1X
1	SPL170	2.024-39	2.625	6.016	EY 170-4-181-1X <i>High angle yoke</i>
1	SPL90	2.024-39	2.626	4.160	EY 90-4-621-1
1	SPL90	2.024-39	2.626	4.160	EY 90-4-631-1X
1	1480	2.024-39	2.625	4.344	EY 3-4-11051-1
1	1480	2.024-39	2.625	4.344	EY 3-4-11061-1X
1	1550	2.024-39	2.625	4.281	EY 4-4-5621-1

Pos	Series	Spline Data	Hub Dia	* to End of Hub	End Fitting Part Number
21065-S, 21065-T (Continued)					
1	1550	2.024-39	2.625	4.281	EY 4-4-5691-1X
1	1550	2.024-39	2.625	4.266	EY 4-4-7551-1X
1	1610	2.024-39	2.625	4.719	EY 5-4-7981-1
1	1610	2.024-39	2.625	4.719	EY 5-4-8131-1X
1	1610	2.024-39	2.625	5.312	EY 5-4-8411X
1	1610	2.024-39	2.625	6.000	EY 5-4-8421X <i>High angle yoke</i>
1	1710	2.024-39	2.625	5.250	EY 6-4-8531X
1	1710	2.024-39	2.625	6.125	EY 6-4-8541X <i>High angle yoke</i>

Pos	Series	Spline Data	Hub Dia	* to End of Hub	End Fitting Part Number
21080-A, 21080-D					
1	SPL100	2.281-44	2.938	4.469	EY 100-4-1381-1X
1	SPL140	2.274-44	2.938	5.190	EY 140-4-1191-1
1	SPL140	2.274-44	2.938	5.190	EY 140-4-1201-1X
1	SPL140	2.143-41	2.938	5.560	EY 140-4-421-1
1	SPL140	2.143-41	2.938	5.560	EY 140-4-431-1X
1	SPL140	2.274-44	2.938	5.190	EY 140-4-441-1
1	SPL140	2.274-44	2.938	5.190	EY 140-4-451-1X
1	SPL170	2.274-44	2.938	5.094	EY 170-4-21-1
1	SPL170	2.274-44	2.938	5.094	EY 170-4-31-1X
1	SPL170	2.143-41	2.938	5.320	EY 170-4-351-1
1	SPL170	2.143-41	2.938	5.320	EY 170-4-361-1X
1	SPL170	2.143-41	2.938	6.680	EY 170-4-371-1 <i>High angle yoke</i>
1	SPL170	2.143-41	2.938	6.680	EY 170-4-381-1X <i>High angle yoke</i>
1	SPL250	2.143-41	2.938	5.490	EY 250-4-131-1
1	SPL250	2.143-41	2.938	5.490	EY 250-4-141-1X
1	SPL250	2.274-44	2.938	5.328	EY 250-4-31-1
1	SPL250	2.274-44	2.938	5.328	EY 250-4-41-1X
1	SPL90	2.281-44	2.938	4.469	EY 90-4-281-1
1	1610	2.274-44	2.938	4.844	EY 5-4-8021-1
1	1610	2.274-44	2.938	4.844	EY 5-4-9101-1X
1	1710	2.274-44	2.938	5.031	EY 6-4-7961
1	1710	2.274-44	2.938	5.031	EY 6-4-7961-1
1	1710	2.274-44	2.938	5.031	EY 6-4-9161-1X
1	1710	2.274-44	2.938	5.031	EY 6-4-9161X
1	1760	2.274-44	2.938	5.094	EY 6.3-4-1321
1	1760	2.274-44	2.938	5.094	EY 6.3-4-1321-1
1	1760	2.274-44	2.938	5.094	EY 6.3-4-1621-1X
1	1760	2.274-44	2.938	5.094	EY 6.3-4-1621X
1	1810	2.274-44	2.938	5.090	EY 6.5-4-4081-1
1	1810	2.274-44	2.938	5.090	EY 6.5-4-4591-1X

Pos	Series	Spline Data	Hub Dia	* to End of Hub	End Fitting Part Number
21080-P					
1	1810	2.143-41	2.938	3.500	CF 6.5-1-2941
1	1710	2.143-41	2.938	5.190	EY 6-4-7311
1	1710	2.143-41	2.938	5.190	EY 6-4-7311-1
1	1710	2.143-41	2.938	6.125	EY 6-4-7551 <i>High angle yoke</i>
1	1710	2.143-41	2.938	6.125	EY 6-4-7551-1 <i>High angle yoke</i>
1	1710	2.143-41	2.938	5.190	EY 6-4-9171-1X
1	1710	2.143-41	2.938	5.190	EY 6-4-9171X
1	1710	2.143-41	2.938	6.125	EY 6-4-9181-1X <i>High angle yoke</i>
1	1710	2.143-41	2.938	6.125	EY 6-4-9181X <i>High angle yoke</i>
1	1760	2.143-41	2.938	5.250	EY 6.3-4-1061

Continued on next page

*C/L to End of Hub for EY (End Yoke); Flange Face to End of Hub for CF (Companion Flange)

■ Hub machined for speedometer gear



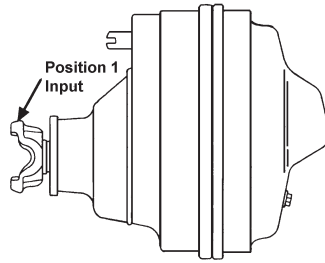

Pos	Series	Spline Data	Hub Dia	* to End of Hub	End Fitting Part Number
-----	--------	-------------	---------	-----------------	-------------------------

21080-P (Continued)

1	1760	2.143-41	2.938	5.250	EY 6.3-4-1061-1
1	1760	2.143-41	2.938	5.250	EY 6.3-4-1631-1X
1	1810	2.143-41	2.938	5.250	EY 6.5-4-4601-1X
1	1810	2.143-41	2.938	5.250	EY 6.5-4-4601X
1	SPL140	2.143-41	2.938	5.560	EY 140-4-421-1
1	SPL140	2.143-41	2.938	5.560	EY 140-4-431-1X
1	SPL170	2.143-41	2.938	5.320	EY 170-4-351-1
1	SPL170	2.143-41	2.938	5.320	EY 170-4-361-1X
1	SPL170	2.143-41	2.938	6.680	EY 170-4-371-1 <i>High angle yoke</i>
1	SPL170	2.143-41	2.938	6.680	EY 170-4-381-1X <i>High angle yoke</i>
1	SPL250	2.143-41	2.938	5.490	EY 250-4-131-1
1	SPL250	2.143-41	2.938	5.490	EY 250-4-141-1X
1	SPL90	2.143-41	2.938	4.562	EY 90-4-471-1
1	SPL90	2.143-41	2.938	4.562	EY 90-4-691-1X
1	1550	2.143-41	2.938	4.500	EY 4-4-5581-1
1	1610	2.143-41	2.938	5.250	EY 5-4-7271-1
1	1610	2.143-41	2.938	6.000	EY 5-4-7561
1	1610	2.143-41	2.938	6.000	EY 5-4-7561-1
1	1610	2.143-41	2.938	5.250	EY 5-4-9111-1X
1	1610	2.143-41	2.938	6.000	EY 5-4-9121-1X
1	1610	2.143-41	2.938	6.000	EY 5-4-9121X

21080-S

1	SPL100	2.281-44	2.938	4.469	EY 100-4-1381-1X
1	SPL140	2.274-44	2.938	5.190	EY 140-4-1191-1
1	SPL140	2.274-44	2.938	5.190	EY 140-4-1201-1X
1	SPL140	2.143-41	2.938	5.560	EY 140-4-421-1
1	SPL140	2.143-41	2.938	5.560	EY 140-4-431-1X
1	SPL140	2.274-44	2.938	5.190	EY 140-4-441-1
1	SPL140	2.274-44	2.938	5.190	EY 140-4-451-1X
1	SPL170	2.274-44	2.938	5.094	EY 170-4-21-1
1	SPL170	2.274-44	2.938	5.094	EY 170-4-31-1X
1	SPL170	2.143-41	2.938	5.320	EY 170-4-351-1
1	SPL170	2.143-41	2.938	5.320	EY 170-4-361-1X
1	SPL170	2.143-41	2.938	6.680	EY 170-4-371-1 <i>High angle yoke</i>
1	SPL170	2.143-41	2.938	6.680	EY 170-4-381-1X <i>High angle yoke</i>
1	SPL250	2.143-41	2.938	5.490	EY 250-4-131-1
1	SPL250	2.143-41	2.938	5.490	EY 250-4-141-1X
1	SPL250	2.274-44	2.938	5.328	EY 250-4-31-1
1	SPL250	2.274-44	2.938	5.328	EY 250-4-41-1X
1	SPL90	2.281-44	2.938	4.469	EY 90-4-281-1
1	1610	2.274-44	2.938	4.844	EY 5-4-8021-1
1	1610	2.274-44	2.938	4.844	EY 5-4-9101-1X
1	1710	2.274-44	2.938	5.031	EY 6-4-7961
1	1710	2.274-44	2.938	5.031	EY 6-4-7961-1
1	1710	2.274-44	2.938	5.031	EY 6-4-9161-1X

Pos	Series	Spline Data	Hub Dia	* to End of Hub	End Fitting Part Number
-----	--------	-------------	---------	-----------------	-------------------------

21080-S (Continued)

1	1710	2.274-44	2.938	5.031	EY 6-4-9161X
1	1760	2.274-44	2.938	5.094	EY 6.3-4-1321
1	1760	2.274-44	2.938	5.094	EY 6.3-4-1321-1
1	1760	2.274-44	2.938	5.094	EY 6.3-4-1621-1X
1	1760	2.274-44	2.938	5.094	EY 6.3-4-1621X
1	1810	2.274-44	2.938	5.090	EY 6.5-4-4081-1
1	1810	2.274-44	2.938	5.090	EY 6.5-4-4591-1X

21080-T

1	1810	2.143-41	2.938	3.500	CF 6.5-1-2941
1	1710	2.143-41	2.938	5.190	EY 6-4-7311
1	1710	2.143-41	2.938	5.190	EY 6-4-7311-1
1	1710	2.143-41	2.938	6.125	EY 6-4-7551 <i>High angle yoke</i>
1	1710	2.143-41	2.938	6.125	EY 6-4-7551-1 <i>High angle yoke</i>
1	1710	2.143-41	2.938	5.190	EY 6-4-9171-1X
1	1710	2.143-41	2.938	5.190	EY 6-4-9171X
1	1710	2.143-41	2.938	6.125	EY 6-4-9181-1X <i>High angle yoke</i>
1	1710	2.143-41	2.938	6.125	EY 6-4-9181X <i>High angle yoke</i>
1	1760	2.143-41	2.938	5.250	EY 6.3-4-1061
1	1760	2.143-41	2.938	5.250	EY 6.3-4-1061-1
1	1760	2.143-41	2.938	5.250	EY 6.3-4-1631-1X
1	1810	2.143-41	2.938	5.250	EY 6.5-4-4601-1X
1	1810	2.143-41	2.938	5.250	EY 6.5-4-4601X
1	SPL140	2.143-41	2.938	5.560	EY 140-4-421-1
1	SPL140	2.143-41	2.938	5.560	EY 140-4-431-1X
1	SPL170	2.143-41	2.938	5.320	EY 170-4-351-1
1	SPL170	2.143-41	2.938	5.320	EY 170-4-361-1X
1	SPL170	2.143-41	2.938	6.680	EY 170-4-371-1 <i>High angle yoke</i>
1	SPL170	2.143-41	2.938	6.680	EY 170-4-381-1X <i>High angle yoke</i>
1	SPL250	2.143-41	2.938	5.490	EY 250-4-131-1
1	SPL250	2.143-41	2.938	5.490	EY 250-4-141-1X
1	SPL90	2.143-41	2.938	4.562	EY 90-4-471-1
1	SPL90	2.143-41	2.938	4.562	EY 90-4-691-1X
1	1550	2.143-41	2.938	4.500	EY 4-4-5581-1
1	1610	2.143-41	2.938	5.250	EY 5-4-7271-1
1	1610	2.143-41	2.938	6.000	EY 5-4-7561
1	1610	2.143-41	2.938	6.000	EY 5-4-7561-1
1	1610	2.143-41	2.938	5.250	EY 5-4-9111-1X
1	1610	2.143-41	2.938	6.000	EY 5-4-9121-1X
1	1610	2.143-41	2.938	6.000	EY 5-4-9121X

21085-P, 21085-T

1	SPL140	2.143-41	2.938	5.560	EY 140-4-431-1X
---	--------	----------	-------	-------	-----------------

*C/L to End of Hub for EY (End Yoke); Flange Face to End of Hub for CF (Companion Flange)

■ Hub machined for speedometer gear



Pos	Series	Spline Data	Hub Dia	* to End of Hub	End Fitting Part Number
21130, 21430					
1	SPL170	2.024-39	2.625	4.938	EY 170-4-161-1X
1	SPL170	2.024-39	2.625	6.016	EY 170-4-181-1X <i>High angle yoke</i>
1	1550	2.024-39	2.625	4.266	EY 4-4-7551-1X
1	1610	2.024-39	2.625	4.719	EY 5-4-8131-1X
1	1610	2.024-39	2.625	5.312	EY 5-4-8411X
1	1610	2.024-39	2.625	6.000	EY 5-4-8421X <i>High angle yoke</i>
1	1710	2.024-39	2.625	5.250	EY 6-4-8531X
1	1710	2.024-39	2.625	6.125	EY 6-4-8541X <i>High angle yoke</i>

Pos	Series	Spline Data	Hub Dia	* to End of Hub	End Fitting Part Number
22060-A, 22060-D					
1	SPL100	2.024-39	3.000	4.750	EY 100-4-951-1
1	SPL100	2.024-39	3.000	4.750	EY 100-4-961-1X
1	SPL140	2.024-39	3.000	4.940	EY 140-4-1151-1
1	SPL140	2.024-39	3.000	4.940	EY 140-4-1161-1X
1	SPL140	2.024-39	3.000	4.940	EY 140-4-361-1
1	SPL140	2.024-39	3.000	4.940	EY 140-4-371-1X
1	SPL170	2.024-39	3.000	5.156	EY 170-4-251-1 <i>High angle yoke</i>
1	SPL170	2.024-39	3.000	5.156	EY 170-4-261-1X
1	SPL170	2.024-39	3.000	6.240	EY 170-4-271-1 <i>High angle yoke</i>
1	SPL170	2.024-39	3.000	6.240	EY 170-4-281-1X <i>High angle yoke</i>
1	SPL55	2.024-39	3.000	4.330	EY 55-4-71-1
1	SPL55	2.024-39	3.000	4.330	EY 55-4-81-1X
1	SPL70	2.024-39	3.000	4.281	EY 70-4-101-1
1	SPL70	2.024-39	3.000	4.281	EY 70-4-111-1X
1	SPL90	2.024-39	3.000	4.750	EY 90-4-241-1
1	SPL90	2.024-39	3.000	4.750	EY 90-4-251-1X
1	1480	2.024-39	3.000	4.344	EY 3-4-13071-1
1	1480	2.024-39	3.000	4.344	EY 3-4-13081-1X
1	1550	2.024-39	3.000	4.281	EY 4-4-7561-1
1	1550	2.024-39	3.000	4.281	EY 4-4-7571-1X
1	1610	2.024-39	3.000	6.000	EY 5-4-8261 <i>High angle yoke</i>
1	1610	2.024-39	3.000	6.000	EY 5-4-8261-1 <i>High angle yoke</i>
1	1610	2.024-39	3.000	4.875	EY 5-4-9221-1
1	1610	2.024-39	3.000	4.875	EY 5-4-9231-1X
1	1610	2.024-39	3.000	6.000	EY 5-4-9241-1X <i>High angle yoke</i>
1	1610	2.024-39	3.000	6.000	EY 5-4-9241X <i>High angle yoke</i>
1	1710	2.024-39	3.000	6.125	EY 6-4-8411 <i>High angle yoke</i>
1	1710	2.024-39	3.000	6.125	EY 6-4-8411-1 <i>High angle yoke</i>
1	1710	2.024-39	3.000	5.250	EY 6-4-8421
1	1710	2.024-39	3.000	5.250	EY 6-4-8421-1
1	1710	2.024-39	3.000	6.125	EY 6-4-8991-1X <i>High angle yoke</i>
1	1710	2.024-39	3.000	6.125	EY 6-4-8991X <i>High angle yoke</i>
1	1710	2.024-39	3.000	5.250	EY 6-4-9031-1X
1	1710	2.024-39	3.000	5.250	EY 6-4-9031X

Pos	Series	Spline Data	Hub Dia	* to End of Hub	End Fitting Part Number
22060-P					
1	SPL100	2.024-39	2.625	4.160	EY 100-4-1071-1
1	SPL100	2.024-39	2.625	4.160	EY 100-4-1081-1X
1	SPL140	2.024-39	2.625	5.030	EY 140-4-551-1 <i>Counterbore at hub end.</i>
1	SPL140	2.024-39	2.625	5.030	EY 140-4-561-1X <i>Counterbore at hub end.</i>
1	SPL170	2.024-39	2.625	4.938	EY 170-4-151-1
1	SPL170	2.024-39	2.625	4.938	EY 170-4-161-1X
1	SPL170	2.024-39	2.625	6.016	EY 170-4-171-1 <i>High angle yoke</i>
1	SPL170	2.024-39	2.625	6.016	EY 170-4-181-1X <i>High angle yoke</i>
1	SPL70	2.024-39	3.000	4.281	EY 70-4-101-1
1	SPL70	2.024-39	3.000	4.281	EY 70-4-111-1X
1	1480	2.024-39	2.625	4.344	EY 3-4-13051-1
1	1480	2.024-39	2.625	4.344	EY 3-4-13061-1X
1	1550	2.024-39	2.625	4.266	EY 4-4-6471-1
1	1550	2.024-39	2.625	4.266	EY 4-4-7551-1X
1	1610	2.024-39	2.625	5.312	EY 5-4-7971
1	1610	2.024-39	2.625	5.312	EY 5-4-7971-1
1	1610	2.024-39	2.625	4.719	EY 5-4-8131-1X
1	1610	2.024-39	2.625	5.312	EY 5-4-8411-1X
1	1610	2.024-39	2.625	5.312	EY 5-4-8411X
1	1610	2.024-39	2.625	6.000	EY 5-4-8421X <i>High angle yoke</i>
1	1710	2.024-39	2.625	6.125	EY 6-4-7981 <i>High angle yoke</i>
1	1710	2.024-39	2.625	6.125	EY 6-4-7981-1 <i>High angle yoke</i>
1	1710	2.024-39	2.625	5.250	EY 6-4-7991
1	1710	2.024-39	2.625	5.250	EY 6-4-7991-1
1	1710	2.024-39	2.625	5.250	EY 6-4-8531-1X
1	1710	2.024-39	2.625	5.250	EY 6-4-8531X
1	1710	2.024-39	2.625	6.125	EY 6-4-8541-1X <i>High angle yoke</i>
1	1710	2.024-39	2.625	6.125	EY 6-4-8541X <i>High angle yoke</i>

Pos	Series	Spline Data	Hub Dia	* to End of Hub	End Fitting Part Number
22060-S					
1	SPL100	2.024-39	3.000	4.750	EY 100-4-951-1
1	SPL100	2.024-39	3.000	4.750	EY 100-4-961-1X
1	SPL140	2.024-39	3.000	4.940	EY 140-4-1151-1
1	SPL140	2.024-39	3.000	4.940	EY 140-4-1161-1X
1	SPL140	2.024-39	3.000	4.940	EY 140-4-361-1
1	SPL140	2.024-39	3.000	4.940	EY 140-4-371-1X
1	SPL170	2.024-39	3.000	5.156	EY 170-4-251-1 <i>High angle yoke</i>
1	SPL170	2.024-39	3.000	5.156	EY 170-4-261-1X
1	SPL170	2.024-39	3.000	6.240	EY 170-4-271-1 <i>High angle yoke</i>
1	SPL170	2.024-39	3.000	6.240	EY 170-4-281-1X <i>High angle yoke</i>
1	SPL55	2.024-39	3.000	4.330	EY 55-4-71-1
1	SPL55	2.024-39	3.000	4.330	EY 55-4-81-1X
1	SPL70	2.024-39	3.000	4.281	EY 70-4-101-1
1	SPL70	2.024-39	3.000	4.281	EY 70-4-111-1X
1	SPL90	2.024-39	3.000	4.750	EY 90-4-241-1
1	SPL90	2.024-39	3.000	4.750	EY 90-4-251-1X
1	1480	2.024-39	3.000	4.344	EY 3-4-13071-1
1	1480	2.024-39	3.000	4.344	EY 3-4-13081-1X

Continued on next page

*C/L to End of Hub for EY (End Yoke); Flange Face to End of Hub for CF (Companion Flange)

■ Hub machined for speedometer gear



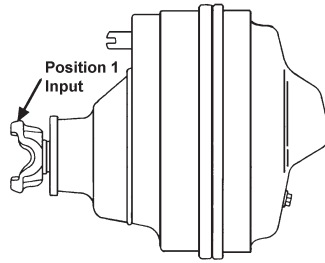

Pos	Series	Spline Data	Hub Dia	* to End of Hub	End Fitting Part Number
22060-S (Continued)					
1	1550	2.024-39	3.000	4.281	EY 4-4-7561-1
1	1550	2.024-39	3.000	4.281	EY 4-4-7571-1X
1	1610	2.024-39	3.000	6.000	EY 5-4-8261 <i>High angle yoke</i>
1	1610	2.024-39	3.000	6.000	EY 5-4-8261-1 <i>High angle yoke</i>
1	1610	2.024-39	3.000	4.875	EY 5-4-9221-1
1	1610	2.024-39	3.000	4.875	EY 5-4-9231-1X
1	1610	2.024-39	3.000	6.000	EY 5-4-9241-1X <i>High angle yoke</i>
1	1610	2.024-39	3.000	6.000	EY 5-4-9241X <i>High angle yoke</i>
1	1710	2.024-39	3.000	6.125	EY 6-4-8411 <i>High angle yoke</i>
1	1710	2.024-39	3.000	6.125	EY 6-4-8411-1 <i>High angle yoke</i>
1	1710	2.024-39	3.000	5.250	EY 6-4-8421
1	1710	2.024-39	3.000	5.250	EY 6-4-8421-1
1	1710	2.024-39	3.000	6.125	EY 6-4-8991-1X <i>High angle yoke</i>
1	1710	2.024-39	3.000	6.125	EY 6-4-8991X <i>High angle yoke</i>
1	1710	2.024-39	3.000	5.250	EY 6-4-9031-1X
1	1710	2.024-39	3.000	5.250	EY 6-4-9031X

Pos	Series	Spline Data	Hub Dia	* to End of Hub	End Fitting Part Number
22060-T					
1	SPL100	2.024-39	2.625	4.160	EY 100-4-1071-1
1	SPL100	2.024-39	2.625	4.160	EY 100-4-1081-1X
1	SPL140	2.024-39	2.625	5.030	EY 140-4-551-1 <i>Counterbore at hub end.</i>
1	SPL140	2.024-39	2.625	5.030	EY 140-4-561-1X <i>Counterbore at hub end.</i>
1	SPL170	2.024-39	2.625	4.938	EY 170-4-151-1
1	SPL170	2.024-39	2.625	4.938	EY 170-4-161-1X
1	SPL70	2.024-39	3.000	4.281	EY 70-4-101-1
1	SPL70	2.024-39	3.000	4.281	EY 70-4-111-1X
1	1480	2.024-39	2.625	4.344	EY 3-4-13051-1
1	1480	2.024-39	2.625	4.344	EY 3-4-13061-1X
1	1550	2.024-39	2.625	4.266	EY 4-4-6471-1
1	1550	2.024-39	2.625	4.266	EY 4-4-7551-1X
1	1610	2.024-39	2.625	5.312	EY 5-4-7971
1	1610	2.024-39	2.625	5.312	EY 5-4-7971-1
1	1610	2.024-39	2.625	6.000	EY 5-4-7991 <i>High angle yoke</i>
1	1610	2.024-39	2.625	4.719	EY 5-4-8131-1X
1	1610	2.024-39	2.625	5.312	EY 5-4-8411-1X
1	1610	2.024-39	2.625	5.312	EY 5-4-8411X
1	1610	2.024-39	2.625	6.000	EY 5-4-8421X <i>High angle yoke</i>
1	1710	2.024-39	2.625	6.125	EY 6-4-7981 <i>High angle yoke</i>
1	1710	2.024-39	2.625	6.125	EY 6-4-7981-1 <i>High angle yoke</i>

Pos	Series	Spline Data	Hub Dia	* to End of Hub	End Fitting Part Number
22060-T (Continued)					
1	1710	2.024-39	2.625	5.250	EY 6-4-7991
1	1710	2.024-39	2.625	5.250	EY 6-4-8531-1X
1	1710	2.024-39	2.625	5.250	EY 6-4-8531X
1	1710	2.024-39	2.625	6.125	EY 6-4-8541-1X <i>High angle yoke</i>
1	1710	2.024-39	2.625	6.125	EY 6-4-8541X <i>High angle yoke</i>
22065-D, 22065-P, 22065-S, 22065-T					
1	SPL140	2.024-39	2.625	4.940	EY 140-4-491-1
1	SPL140	2.024-39	2.625	4.940	EY 140-4-501-1X
1	SPL170	2.024-39	2.625	4.938	EY 170-4-161-1X
1	SPL170	2.024-39	2.625	6.016	EY 170-4-181-1X <i>High angle yoke</i>
1	SPL90	2.024-39	2.626	4.160	EY 90-4-621-1
1	SPL90	2.024-39	2.626	4.160	EY 90-4-631-1X
1	1480	2.024-39	2.625	4.344	EY 3-4-11051-1
1	1480	2.024-39	2.625	4.344	EY 3-4-11061-1X
1	1550	2.024-39	2.625	4.281	EY 4-4-5621-1
1	1550	2.024-39	2.625	4.281	EY 4-4-5691-1X
1	1550	2.024-39	2.625	4.266	EY 4-4-7551-1X
1	1610	2.024-39	2.625	4.719	EY 5-4-7981-1
1	1610	2.024-39	2.625	4.719	EY 5-4-8131-1X
1	1610	2.024-39	2.625	5.312	EY 5-4-8411X
1	1610	2.024-39	2.625	6.000	EY 5-4-8421X <i>High angle yoke</i>
1	1710	2.024-39	2.625	5.250	EY 6-4-8531X
1	1710	2.024-39	2.625	6.125	EY 6-4-8541X <i>High angle yoke</i>

Pos	Series	Spline Data	Hub Dia	* to End of Hub	End Fitting Part Number
22070-D, 22070-P, 22070-S, 22070-T					
1	1810	2.143-41	2.938	3.500	CF 6.5-1-2941
1	1710	2.143-41	2.938	5.190	EY 6-4-7311
1	1710	2.143-41	2.938	5.190	EY 6-4-7311-1
1	1710	2.143-41	2.938	6.125	EY 6-4-7551 <i>High angle yoke</i>
1	1710	2.143-41	2.938	6.125	EY 6-4-7551-1 <i>High angle yoke</i>
1	1710	2.143-41	2.938	5.190	EY 6-4-9171-1X
1	1710	2.143-41	2.938	5.190	EY 6-4-9171X
1	1710	2.143-41	2.938	6.125	EY 6-4-9181-1X <i>High angle yoke</i>
1	1710	2.143-41	2.938	6.125	EY 6-4-9181X <i>High angle yoke</i>
1	1760	2.143-41	2.938	5.250	EY 6.3-4-1061
1	1760	2.143-41	2.938	5.250	EY 6.3-4-1061-1
1	1760	2.143-41	2.938	5.250	EY 6.3-4-1631-1X
1	1810	2.143-41	2.938	5.250	EY 6.5-4-4601-1X
1	1810	2.143-41	2.938	5.250	EY 6.5-4-4601X
1	SPL100	2.143-41	2.938	4.562	EY 100-4-1051-1
1	SPL100	2.143-41	2.938	4.562	EY 100-4-1061-1X
1	SPL140	2.143-41	2.938	5.560	EY 140-4-421-1

*C/L to End of Hub for EY (End Yoke); Flange Face to End of Hub for CF (Companion Flange)

■ Hub machined for speedometer gear



Pos	Series	Spline Data	Hub Dia	* to End of Hub	End Fitting Part Number
22070-D, 22070-P, 22070-S, 22070-T (Continued)					
1	SPL140	2.143-41	2.938	5.560	EY 140-4-431-1X
1	SPL170	2.143-41	2.938	5.320	EY 170-4-351-1
1	SPL170	2.143-41	2.938	5.320	EY 170-4-361-1X
1	SPL170	2.143-41	2.938	6.680	EY 170-4-371-1 <i>High angle yoke</i>
1	SPL170	2.143-41	2.938	6.680	EY 170-4-381-1X <i>High angle yoke</i>
1	SPL250	2.143-41	2.938	5.490	EY 250-4-131-1
1	SPL250	2.143-41	2.938	5.490	EY 250-4-141-1X
1	SPL90	2.143-41	2.938	4.562	EY 90-4-471-1
1	SPL90	2.143-41	2.938	4.562	EY 90-4-691-1X
1	1550	2.143-41	2.938	4.500	EY 4-4-5581-1
1	1610	2.143-41	2.938	5.250	EY 5-4-7271-1
1	1610	2.143-41	2.938	6.000	EY 5-4-7561
1	1610	2.143-41	2.938	6.000	EY 5-4-7561-1
1	1610	2.143-41	2.938	5.250	EY 5-4-9111-1X
1	1610	2.143-41	2.938	6.000	EY 5-4-9121-1X
1	1610	2.143-41	2.938	6.000	EY 5-4-9121X

Pos	Series	Spline Data	Hub Dia	* to End of Hub	End Fitting Part Number
22080-D					
S	SPL250	2.274-44	2.938	5.328	EY 250-4-31-1
1	SPL100	2.281-44	2.938	4.469	EY 100-4-1381-1X
1	SPL140	2.274-44	2.938	5.190	EY 140-4-1191-1
1	SPL140	2.274-44	2.938	5.190	EY 140-4-1201-1X
1	SPL140	2.143-41	2.938	5.560	EY 140-4-421-1
1	SPL140	2.143-41	2.938	5.560	EY 140-4-431-1X
1	SPL140	2.274-44	2.938	5.190	EY 140-4-441-1
1	SPL140	2.274-44	2.938	5.190	EY 140-4-451-1X
1	SPL170	2.274-44	2.938	5.094	EY 170-4-21-1
1	SPL170	2.274-44	2.938	5.094	EY 170-4-31-1X
1	SPL170	2.143-41	2.938	5.320	EY 170-4-351-1
1	SPL170	2.143-41	2.938	5.320	EY 170-4-361-1X
1	SPL170	2.143-41	2.938	6.680	EY 170-4-371-1 <i>High angle yoke</i>
1	SPL170	2.143-41	2.938	6.680	EY 170-4-381-1X <i>High angle yoke</i>
1	SPL250	2.143-41	2.938	5.490	EY 250-4-131-1
1	SPL250	2.143-41	2.938	5.490	EY 250-4-141-1X
1	SPL250	2.274-44	2.938	5.328	EY 250-4-41-1X
1	SPL90	2.281-44	2.938	4.469	EY 90-4-281-1
1	1610	2.274-44	2.938	4.844	EY 5-4-8021-1
1	1610	2.274-44	2.938	4.844	EY 5-4-9101-1X
1	1710	2.274-44	2.938	5.031	EY 6-4-7961
1	1710	2.274-44	2.938	5.031	EY 6-4-7961-1
1	1710	2.274-44	2.938	5.031	EY 6-4-9161-1X
1	1710	2.274-44	2.938	5.031	EY 6-4-9161X
1	1760	2.274-44	2.938	5.094	EY 6.3-4-1321
1	1760	2.274-44	2.938	5.094	EY 6.3-4-1321-1
1	1760	2.274-44	2.938	5.094	EY 6.3-4-1621-1X
1	1760	2.274-44	2.938	5.094	EY 6.3-4-1621X
1	1810	2.274-44	2.938	5.090	EY 6.5-4-4081-1
1	1810	2.274-44	2.938	5.090	EY 6.5-4-4591-1X

Pos	Series	Spline Data	Hub Dia	* to End of Hub	End Fitting Part Number
22080-P					
1	SPL170	2.143-41	2.938	5.320	EY 170-4-361-1X
1	SPL170	2.143-41	2.938	6.680	EY 170-4-381-1X <i>High angle yoke</i>
1	1810	2.143-41	2.938	5.250	EY 6.5-4-4601X

Pos	Series	Spline Data	Hub Dia	* to End of Hub	End Fitting Part Number
22080-S					
S	SPL250	2.274-44	2.938	5.328	EY 250-4-31-1
1	SPL100	2.281-44	2.938	4.469	EY 100-4-1381-1X
1	SPL140	2.274-44	2.938	5.190	EY 140-4-1191-1
1	SPL140	2.274-44	2.938	5.190	EY 140-4-1201-1X
1	SPL140	2.143-41	2.938	5.560	EY 140-4-421-1
1	SPL140	2.143-41	2.938	5.560	EY 140-4-431-1X
1	SPL140	2.274-44	2.938	5.190	EY 140-4-441-1
1	SPL140	2.274-44	2.938	5.190	EY 140-4-451-1X
1	SPL170	2.274-44	2.938	5.094	EY 170-4-21-1
1	SPL170	2.274-44	2.938	5.094	EY 170-4-31-1X
1	SPL170	2.143-41	2.938	5.320	EY 170-4-351-1
1	SPL170	2.143-41	2.938	5.320	EY 170-4-361-1X
1	SPL170	2.143-41	2.938	6.680	EY 170-4-371-1 <i>High angle yoke</i>
1	SPL170	2.143-41	2.938	6.680	EY 170-4-381-1X <i>High angle yoke</i>
1	SPL250	2.143-41	2.938	5.490	EY 250-4-131-1
1	SPL250	2.143-41	2.938	5.490	EY 250-4-141-1X
1	SPL250	2.274-44	2.938	5.328	EY 250-4-41-1X
1	SPL90	2.281-44	2.938	4.469	EY 90-4-281-1
1	1610	2.274-44	2.938	4.844	EY 5-4-8021-1
1	1610	2.274-44	2.938	4.844	EY 5-4-9101-1X
1	1710	2.274-44	2.938	5.031	EY 6-4-7961
1	1710	2.274-44	2.938	5.031	EY 6-4-7961-1
1	1710	2.274-44	2.938	5.031	EY 6-4-9161-1X
1	1710	2.274-44	2.938	5.031	EY 6-4-9161X
1	1760	2.274-44	2.938	5.094	EY 6.3-4-1321
1	1760	2.274-44	2.938	5.094	EY 6.3-4-1321-1
1	1760	2.274-44	2.938	5.094	EY 6.3-4-1621-1X
1	1760	2.274-44	2.938	5.094	EY 6.3-4-1621X
1	1810	2.274-44	2.938	5.090	EY 6.5-4-4081-1
1	1810	2.274-44	2.938	5.090	EY 6.5-4-4591-1X

Pos	Series	Spline Data	Hub Dia	* to End of Hub	End Fitting Part Number
22080-T, 22082-P, 22082-T, 22085-P, 22085-T					
1	SPL170	2.143-41	2.938	5.320	EY 170-4-361-1X
1	SPL170	2.143-41	2.938	6.680	EY 170-4-381-1X <i>High angle yoke</i>
1	1810	2.143-41	2.938	5.250	EY 6.5-4-4601X

Pos	Series	Spline Data	Hub Dia	* to End of Hub	End Fitting Part Number
22120, 22121					
1	1610	1.962-10	2.625	4.719	EY 5-4-5121-1X
1	1610	1.962-10	2.625	4.719	EY 5-4-5121X
1	1710	1.962-10	2.625	5.250	EY 6-4-5151X <i>Chamfered Counterbore</i>
1	1760	1.964-10	2.625	5.625	EY 6.3-4-221X <i>Chamfered Counterbore</i>

Pos	Series	Spline Data	Hub Dia	* to End of Hub	End Fitting Part Number
22123					
1	1610	1.962-10	2.625	5.312	EY 5-4-8901-1X <i>C'bore depth is chamfered</i>

Pos	Series	Spline Data	Hub Dia	* to End of Hub	End Fitting Part Number
22130					
1	SPL170	2.024-39	2.625	4.938	EY 170-4-161-1X
1	SPL170	2.024-39	2.625	6.016	EY 170-4-181-1X <i>High angle yoke</i>
1	1550	2.024-39	2.625	4.266	EY 4-4-7551-1X
1	1610	2.024-39	2.625	6.000	EY 5-4-8421X <i>High angle yoke</i>
1	1710	2.024-39	2.625	4.719	EY 5-4-8131-1X
1	1710	2.024-39	2.625	5.312	EY 5-4-8411X
1	1710	2.024-39	2.625	5.250	EY 6-4-8531X
1	1710	2.024-39	2.625	6.125	EY 6-4-8541X <i>High angle yoke</i>

*C/L to End of Hub for EY (End Yoke); Flange Face to End of Hub for CF (Companion Flange)

■ Hub machined for speedometer gear



Important: See Safety Information in General Information Section (J300P-GI)

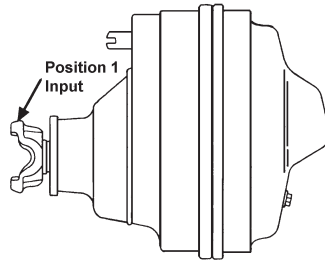

Pos	Series	Spline Data	Hub Dia	* to End of Hub	End Fitting Part Number
22130-T					
1	SPL100	2.024-39	2.625	4.160	EY 100-4-1071-1
1	SPL100	2.024-39	2.625	4.160	EY 100-4-1081-1X
1	SPL140	2.024-39	2.625	5.030	EY 140-4-551-1 <i>Counterbore at hub end.</i>
1	SPL140	2.024-39	2.625	5.030	EY 140-4-561-1X <i>Counterbore at hub end.</i>
1	SPL170	2.024-39	2.625	4.938	EY 170-4-151-1
1	SPL170	2.024-39	2.625	4.938	EY 170-4-161-1X
1	SPL170	2.024-39	2.625	6.016	EY 170-4-181-1X <i>High angle yoke</i>
1	SPL70	2.024-39	3.000	4.281	EY 70-4-101-1
1	SPL70	2.024-39	3.000	4.281	EY 70-4-111-1X
1	1480	2.024-39	2.625	4.344	EY 3-4-13051-1
1	1480	2.024-39	2.625	4.344	EY 3-4-13061-1X
1	1550	2.024-39	2.625	4.266	EY 4-4-6471-1
1	1550	2.024-39	2.625	4.266	EY 4-4-7551-1X
1	1610	2.024-39	2.625	5.312	EY 5-4-7971
1	1610	2.024-39	2.625	5.312	EY 5-4-7971-1
1	1610	2.024-39	2.625	6.000	EY 5-4-7991 <i>High angle yoke</i>
1	1610	2.024-39	2.625	5.312	EY 5-4-8411-1X
1	1610	2.024-39	2.625	5.312	EY 5-4-8411X
1	1610	2.024-39	2.625	6.000	EY 5-4-8421X <i>High angle yoke</i>
1	1710	2.024-39	2.625	6.125	EY 6-4-7981 <i>High angle yoke</i>
1	1710	2.024-39	2.625	6.125	EY 6-4-7981-1 <i>High angle yoke</i>
1	1710	2.024-39	2.625	5.250	EY 6-4-7991 <i>High angle yoke</i>
1	1710	2.024-39	2.625	5.250	EY 6-4-8531-1X
1	1710	2.024-39	2.625	5.250	EY 6-4-8531X
1	1710	2.024-39	2.625	6.125	EY 6-4-8541-1X <i>High angle yoke</i>
1	1710	2.024-39	2.625	6.125	EY 6-4-8541X <i>High angle yoke</i>
22207					
1	SPL100	2.143-41	2.938	4.562	EY 100-4-1061-1X
1	SPL90	2.143-41	2.938	4.562	EY 90-4-471-1
22220, 22320					
1	1610	1.962-10	2.625	4.719	EY 5-4-5121-1X
1	1610	1.962-10	2.625	4.719	EY 5-4-5121X
1	1710	1.962-10	2.625	5.250	EY 6-4-5151X <i>Chamfered Counterbore</i>
1	1760	1.964-10	2.625	5.625	EY 6.3-4-221X <i>Chamfered Counterbore</i>
22430					
1	SPL170	2.024-39	2.625	4.938	EY 170-4-161-1X
1	SPL170	2.024-39	2.625	6.016	EY 170-4-181-1X <i>High angle yoke</i>
1	1550	2.024-39	2.625	4.266	EY 4-4-7551-1X
1	1610	2.024-39	2.625	4.719	EY 5-4-8131-1X
1	1610	2.024-39	2.625	5.312	EY 5-4-8411X

Pos	Series	Spline Data	Hub Dia	* to End of Hub	End Fitting Part Number
22430 (Continued)					
1	1610	2.024-39	2.625	6.000	EY 5-4-8421X <i>High angle yoke</i>
1	1710	2.024-39	2.625	5.250	EY 6-4-8531X
1	1710	2.024-39	2.625	6.125	EY 6-4-8541X <i>High angle yoke</i>
22500, 22501					
1	1610	2.149-16	2.938	6.250	EY 5-4-5161-1X
1	1610	2.149-16	2.938	6.250	EY 5-4-5161X <i>High angle yoke</i>
1	1710	2.149-16	2.938	5.500	EY 6-4-4171-1X
1	1710	2.149-16	2.938	5.500	EY 6-4-4171X
1	1760	2.149-16	2.938	5.812	EY 6.3-4-251-1X
1	1760	2.149-16	2.938	5.812	EY 6.3-4-251X
1	1810	2.149-16	2.938	5.812	EY 6.5-4-2291
1	1810	2.149-16	2.938	5.812	EY 6.5-4-2291-1
1	1810	2.149-16	2.938	5.812	EY 6.5-4-2401-1X
1	1810	2.149-16	2.938	5.812	EY 6.5-4-2401X
23060-D, 23060-S					
1	SPL100	2.281-44	2.938	4.469	EY 100-4-1381-1X
1	SPL140	2.274-44	2.938	5.190	EY 140-4-1191-1
1	SPL140	2.274-44	2.938	5.190	EY 140-4-1201-1X
1	SPL140	2.143-41	2.938	5.560	EY 140-4-421-1
1	SPL140	2.143-41	2.938	5.560	EY 140-4-431-1X
1	SPL140	2.274-44	2.938	5.190	EY 140-4-441-1
1	SPL140	2.274-44	2.938	5.190	EY 140-4-451-1X
1	SPL170	2.274-44	2.938	5.094	EY 170-4-21-1
1	SPL170	2.274-44	2.938	5.094	EY 170-4-31-1X
1	SPL170	2.143-41	2.938	5.320	EY 170-4-351-1
1	SPL170	2.143-41	2.938	5.320	EY 170-4-361-1X
1	SPL170	2.143-41	2.938	6.680	EY 170-4-371-1 <i>High angle yoke</i>
1	SPL170	2.143-41	2.938	6.680	EY 170-4-381-1X <i>High angle yoke</i>
1	SPL250	2.143-41	2.938	5.490	EY 250-4-131-1
1	SPL250	2.143-41	2.938	5.490	EY 250-4-141-1X
1	SPL250	2.274-44	2.938	5.328	EY 250-4-41-1X
1	SPL90	2.281-44	2.938	4.469	EY 90-4-281-1
1	1610	2.274-44	2.938	4.844	EY 5-4-8021-1
1	1610	2.274-44	2.938	4.844	EY 5-4-9101-1X
1	1710	2.274-44	2.938	5.031	EY 6-4-7961
1	1710	2.274-44	2.938	5.031	EY 6-4-7961-1
1	1710	2.274-44	2.938	5.031	EY 6-4-9161-1X
1	1710	2.274-44	2.938	5.031	EY 6-4-9161X
1	1760	2.274-44	2.938	5.094	EY 6.3-4-1321
1	1760	2.274-44	2.938	5.094	EY 6.3-4-1321-1
1	1760	2.274-44	2.938	5.094	EY 6.3-4-1621-1X
1	1760	2.274-44	2.938	5.094	EY 6.3-4-1621X
1	1810	2.274-44	2.938	5.090	EY 6.5-4-4081-1
1	1810	2.274-44	2.938	5.090	EY 6.5-4-4591-1X

*C/L to End of Hub for EY (End Yoke); Flange Face to End of Hub for CF (Companion Flange)

■ Hub machined for speedometer gear



Pos	Series	Spline Data	Hub Dia	* to End of Hub	End Fitting Part Number
23070-D					
1	1810	2.143-41	2.938	3.500	CF 6.5-1-2941
1	1710	2.143-41	2.938	5.190	EY 6-4-7311
1	1710	2.143-41	2.938	5.190	EY 6-4-7311-1
1	1710	2.143-41	2.938	6.125	EY 6-4-7551 <i>High angle yoke</i>
1	1710	2.143-41	2.938	6.125	EY 6-4-7551-1 <i>High angle yoke</i>
1	1760	2.143-41	2.938	5.250	EY 6.3-4-1061
1	1760	2.143-41	2.938	5.250	EY 6.3-4-1061-1
1	1810	2.143-41	2.938	5.250	EY 6.5-4-4601-1X
1	1810	2.143-41	2.938	5.250	EY 6.5-4-4601X
1	SPL100	2.143-41	2.938	4.562	EY 100-4-1051-1
1	SPL100	2.143-41	2.938	4.562	EY 100-4-1061-1X
1	SPL140	2.143-41	2.938	5.560	EY 140-4-421-1
1	SPL140	2.143-41	2.938	5.560	EY 140-4-431-1X
1	SPL170	2.143-41	2.938	5.320	EY 170-4-351-1
1	SPL170	2.143-41	2.938	5.320	EY 170-4-361-1X
1	SPL170	2.143-41	2.938	6.680	EY 170-4-371-1 <i>High angle yoke</i>
1	SPL170	2.143-41	2.938	6.680	EY 170-4-381-1X <i>High angle yoke</i>
1	SPL250	2.143-41	2.938	5.490	EY 250-4-131-1
1	SPL250	2.143-41	2.938	5.490	EY 250-4-141-1X
1	SPL90	2.143-41	2.938	4.562	EY 90-4-471-1
1	SPL90	2.143-41	2.938	4.562	EY 90-4-691-1X
1	1550	2.143-41	2.938	4.500	EY 4-4-5581-1
1	1550	2.143-41	2.938	4.500	EY 4-4-5701-1X
1	1610	2.143-41	2.938	5.250	EY 5-4-7271-1
1	1610	2.143-41	2.938	5.250	EY 5-4-7311-1X
1	1610	2.143-41	2.938	6.000	EY 5-4-7561
1	1610	2.143-41	2.938	6.000	EY 5-4-7561-1
1	1710	2.143-41	2.938	5.190	EY 6-4-7321-1X
1	1710	2.143-41	2.938	6.125	EY 6-4-7561X <i>High angle yoke</i>
1	1760	2.143-41	2.938	5.250	EY 6.3-4-1071-1X
1	1810	2.143-41	2.938	5.250	EY 6.5-4-3691-1X
23070-P					
1	1810	2.143-41	2.938	3.500	CF 6.5-1-2941
1	1710	2.143-41	2.938	5.190	EY 6-4-7311
1	1710	2.143-41	2.938	5.190	EY 6-4-7311-1
1	1710	2.143-41	2.938	6.125	EY 6-4-7551 <i>High angle yoke</i>
1	1710	2.143-41	2.938	6.125	EY 6-4-7551-1 <i>High angle yoke</i>
1	1760	2.143-41	2.938	5.250	EY 6.3-4-1061
1	1760	2.143-41	2.938	5.250	EY 6.3-4-1061-1
1	SPL100	2.143-41	2.938	4.562	EY 100-4-1051-1
1	SPL100	2.143-41	2.938	4.562	EY 100-4-1061-1X
1	SPL140	2.143-41	2.938	5.560	EY 140-4-421-1
1	SPL140	2.143-41	2.938	5.560	EY 140-4-431-1X
1	SPL170	2.143-41	2.938	5.320	EY 170-4-351-1
1	SPL170	2.143-41	2.938	5.320	EY 170-4-361-1X
1	SPL170	2.143-41	2.938	6.680	EY 170-4-371-1 <i>High angle yoke</i>
1	SPL170	2.143-41	2.938	6.680	EY 170-4-381-1X <i>High angle yoke</i>
1	SPL250	2.143-41	2.938	5.490	EY 250-4-131-1
1	SPL250	2.143-41	2.938	5.490	EY 250-4-141-1X
1	SPL90	2.143-41	2.938	4.562	EY 90-4-471-1
1	SPL90	2.143-41	2.938	4.562	EY 90-4-691-1X

Pos	Series	Spline Data	Hub Dia	* to End of Hub	End Fitting Part Number
23070-P (Continued)					
1	1550	2.143-41	2.938	4.500	EY 4-4-5581-1
1	1550	2.143-41	2.938	4.500	EY 4-4-5701-1X
1	1610	2.143-41	2.938	5.250	EY 5-4-7271-1
1	1610	2.143-41	2.938	5.250	EY 5-4-7311-1X
1	1610	2.143-41	2.938	6.000	EY 5-4-7561
1	1610	2.143-41	2.938	6.000	EY 5-4-7561-1
1	1610	2.143-41	2.938	5.250	EY 5-4-9111-1X
1	1610	2.143-41	2.938	6.000	EY 5-4-9121X
1	1710	2.143-41	2.938	5.190	EY 6-4-7321-1X
1	1710	2.143-41	2.938	6.125	EY 6-4-7561X <i>High angle yoke</i>
1	1710	2.143-41	2.938	6.125	EY 6-4-9181-1X <i>High angle yoke</i>
1	1710	2.143-41	2.938	6.125	EY 6-4-9181X <i>High angle yoke</i>
1	1760	2.143-41	2.938	5.250	EY 6.3-4-1071-1X
1	1810	2.143-41	2.938	5.250	EY 6.5-4-3691-1X
23070-S, 23070-T					
1	1810	2.143-41	2.938	3.500	CF 6.5-1-2941
1	1710	2.143-41	2.938	5.190	EY 6-4-7311
1	1710	2.143-41	2.938	5.190	EY 6-4-7311-1
1	1710	2.143-41	2.938	6.125	EY 6-4-7551 <i>High angle yoke</i>
1	1710	2.143-41	2.938	6.125	EY 6-4-7551-1 <i>High angle yoke</i>
1	1760	2.143-41	2.938	5.250	EY 6.3-4-1061
1	1760	2.143-41	2.938	5.250	EY 6.3-4-1061-1
1	1810	2.143-41	2.938	5.250	EY 6.5-4-4601-1X
1	1810	2.143-41	2.938	5.250	EY 6.5-4-4601X
1	SPL100	2.143-41	2.938	4.562	EY 100-4-1051-1
1	SPL100	2.143-41	2.938	4.562	EY 100-4-1061-1X
1	SPL140	2.143-41	2.938	5.560	EY 140-4-421-1
1	SPL140	2.143-41	2.938	5.560	EY 140-4-431-1X
1	SPL170	2.143-41	2.938	5.320	EY 170-4-351-1
1	SPL170	2.143-41	2.938	5.320	EY 170-4-361-1X
1	SPL170	2.143-41	2.938	6.680	EY 170-4-371-1 <i>High angle yoke</i>
1	SPL170	2.143-41	2.938	6.680	EY 170-4-381-1X <i>High angle yoke</i>
1	SPL250	2.143-41	2.938	5.490	EY 250-4-131-1
1	SPL250	2.143-41	2.938	5.490	EY 250-4-141-1X
1	SPL70	2.143-41	2.938	4.555	EY 70-4-141-1
1	SPL70	2.143-41	2.938	4.555	EY 70-4-151-1X
1	SPL90	2.143-41	2.938	4.562	EY 90-4-471-1
1	SPL90	2.143-41	2.938	4.562	EY 90-4-691-1X
1	1550	2.143-41	2.938	4.500	EY 4-4-5581-1
1	1550	2.143-41	2.938	4.500	EY 4-4-5701-1X
1	1610	2.143-41	2.938	5.250	EY 5-4-7271-1
1	1610	2.143-41	2.938	5.250	EY 5-4-7311-1X
1	1610	2.143-41	2.938	6.000	EY 5-4-7561
1	1610	2.143-41	2.938	6.000	EY 5-4-7561-1
1	1610	2.143-41	2.938	5.250	EY 5-4-9111-1X
1	1610	2.143-41	2.938	6.000	EY 5-4-9121X
1	1710	2.143-41	2.938	5.190	EY 6-4-7321-1X
1	1710	2.143-41	2.938	6.125	EY 6-4-7561X <i>High angle yoke</i>
1	1710	2.143-41	2.938	6.125	EY 6-4-9181-1X <i>High angle yoke</i>

Continued on next page

*C/L to End of Hub for EY (End Yoke); Flange Face to End of Hub for CF (Companion Flange)

■ Hub machined for speedometer gear



Important: See Safety Information in General Information Section (J300P-GI)

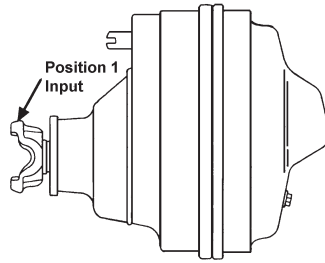

Pos	Series	Spline Data	Hub Dia	* to End of Hub	End Fitting Part Number
-----	--------	-------------	---------	-----------------	-------------------------

23070-S, 23070-T (Continued)					
1	1710	2.143-41	2.938	6.125	EY 6-4-9181X <i>High angle yoke</i>
1	1760	2.143-41	2.938	5.250	EY 6.3-4-1071-1X
1	1760	2.143-41	2.938	5.250	EY 6.3-4-1071X
1	1810	2.143-41	2.938	5.250	EY 6.5-4-3681
1	1810	2.143-41	2.938	5.250	EY 6.5-4-3681-1
1	1810	2.143-41	2.938	5.250	EY 6.5-4-3691-1X
1	1810	2.143-41	2.938	5.250	EY 6.5-4-3691X

23080-D					
1	SPL100	2.281-44	2.938	4.469	EY 100-4-1381-1X
1	SPL140	2.274-44	2.938	5.190	EY 140-4-1191-1
1	SPL140	2.274-44	2.938	5.190	EY 140-4-1201-1X
1	SPL140	2.143-41	2.938	5.560	EY 140-4-421-1
1	SPL140	2.143-41	2.938	5.560	EY 140-4-431-1X
1	SPL140	2.274-44	2.938	5.190	EY 140-4-441-1
1	SPL140	2.274-44	2.938	5.190	EY 140-4-451-1X
1	SPL170	2.274-44	2.938	5.094	EY 170-4-21-1
1	SPL170	2.274-44	2.938	5.094	EY 170-4-31-1X
1	SPL170	2.143-41	2.938	5.320	EY 170-4-351-1
1	SPL170	2.143-41	2.938	5.320	EY 170-4-361-1X
1	SPL170	2.143-41	2.938	6.680	EY 170-4-371-1 <i>High angle yoke</i>
1	SPL170	2.143-41	2.938	6.680	EY 170-4-381-1X <i>High angle yoke</i>
1	SPL250	2.143-41	2.938	5.490	EY 250-4-131-1
1	SPL250	2.143-41	2.938	5.490	EY 250-4-141-1X
1	SPL250	2.274-44	2.938	5.328	EY 250-4-31-1
1	SPL250	2.274-44	2.938	5.328	EY 250-4-41-1X
1	SPL90	2.281-44	2.938	4.469	EY 90-4-281-1
1	1610	2.274-44	2.938	4.844	EY 5-4-8021-1
1	1610	2.274-44	2.938	4.844	EY 5-4-9101-1X
1	1710	2.274-44	2.938	5.031	EY 6-4-7961
1	1710	2.274-44	2.938	5.031	EY 6-4-7961-1
1	1710	2.274-44	2.938	5.031	EY 6-4-9161-1X
1	1760	2.274-44	2.938	5.094	EY 6.3-4-1321
1	1760	2.274-44	2.938	5.094	EY 6.3-4-1321-1
1	1760	2.274-44	2.938	5.094	EY 6.3-4-1621-1X
1	1760	2.274-44	2.938	5.094	EY 6.3-4-1621X
1	1810	2.274-44	2.938	5.090	EY 6.5-4-4081-1
1	1810	2.274-44	2.938	5.090	EY 6.5-4-4591-1X

23080-P					
1	1810	2.143-41	2.938	3.500	CF 6.5-1-2941
1	1710	2.143-41	2.938	5.190	EY 6-4-7311
1	1710	2.143-41	2.938	5.190	EY 6-4-7311-1
1	1710	2.143-41	2.938	6.125	EY 6-4-7551 <i>High angle yoke</i>
1	1710	2.143-41	2.938	6.125	EY 6-4-7551-1 <i>High angle yoke</i>
1	1710	2.143-41	2.938	5.190	EY 6-4-9171-1X

Pos	Series	Spline Data	Hub Dia	* to End of Hub	End Fitting Part Number
-----	--------	-------------	---------	-----------------	-------------------------

23080-P (Continued)					
1	1710	2.143-41	2.938	5.190	EY 6-4-9171X
1	1710	2.143-41	2.938	6.125	EY 6-4-9181-1X <i>High angle yoke</i>
1	1710	2.143-41	2.938	6.125	EY 6-4-9181X <i>High angle yoke</i>
1	1760	2.143-41	2.938	5.250	EY 6.3-4-1061
1	1760	2.143-41	2.938	5.250	EY 6.3-4-1061-1
1	1760	2.143-41	2.938	5.250	EY 6.3-4-1631-1X
1	1810	2.143-41	2.938	5.250	EY 6.5-4-4601-1X
1	1810	2.143-41	2.938	5.250	EY 6.5-4-4601X
1	SPL100	2.143-41	2.938	4.562	EY 100-4-1051-1
1	SPL100	2.143-41	2.938	4.562	EY 100-4-1061-1X
1	SPL140	2.143-41	2.938	5.560	EY 140-4-421-1
1	SPL140	2.143-41	2.938	5.560	EY 140-4-431-1X
1	SPL170	2.143-41	2.938	5.320	EY 170-4-351-1
1	SPL170	2.143-41	2.938	5.320	EY 170-4-361-1X
1	SPL170	2.143-41	2.938	6.680	EY 170-4-371-1 <i>High angle yoke</i>
1	SPL170	2.143-41	2.938	6.680	EY 170-4-381-1X <i>High angle yoke</i>
1	SPL250	2.143-41	2.938	5.490	EY 250-4-131-1
1	SPL250	2.143-41	2.938	5.490	EY 250-4-141-1X
1	SPL90	2.143-41	2.938	4.562	EY 90-4-471-1
1	SPL90	2.143-41	2.938	4.562	EY 90-4-691-1X
1	1550	2.143-41	2.938	4.500	EY 4-4-5581-1
1	1610	2.143-41	2.938	5.250	EY 5-4-7271-1
1	1610	2.143-41	2.938	6.000	EY 5-4-7561
1	1610	2.143-41	2.938	6.000	EY 5-4-7561-1
1	1610	2.143-41	2.938	5.250	EY 5-4-9111-1X
1	1610	2.143-41	2.938	6.000	EY 5-4-9121-1X
1	1610	2.143-41	2.938	6.000	EY 5-4-9121X

23080-S					
1	SPL100	2.281-44	2.938	4.469	EY 100-4-1381-1X
1	SPL140	2.274-44	2.938	5.190	EY 140-4-1191-1
1	SPL140	2.274-44	2.938	5.190	EY 140-4-1201-1X
1	SPL140	2.143-41	2.938	5.560	EY 140-4-421-1
1	SPL140	2.143-41	2.938	5.560	EY 140-4-431-1X
1	SPL140	2.274-44	2.938	5.190	EY 140-4-441-1
1	SPL140	2.274-44	2.938	5.190	EY 140-4-451-1X
1	SPL170	2.274-44	2.938	5.094	EY 170-4-21-1
1	SPL170	2.274-44	2.938	5.094	EY 170-4-31-1X
1	SPL170	2.143-41	2.938	5.320	EY 170-4-351-1
1	SPL170	2.143-41	2.938	5.320	EY 170-4-361-1X
1	SPL170	2.143-41	2.938	6.680	EY 170-4-371-1 <i>High angle yoke</i>
1	SPL170	2.143-41	2.938	6.680	EY 170-4-381-1X <i>High angle yoke</i>
1	SPL250	2.143-41	2.938	5.490	EY 250-4-131-1
1	SPL250	2.143-41	2.938	5.490	EY 250-4-141-1X

*C/L to End of Hub for EY (End Yoke); Flange Face to End of Hub for CF (Companion Flange)

■ Hub machined for speedometer gear



Pos	Series	Spline Data	Hub Dia	* to End of Hub	End Fitting Part Number
23080-S (Continued)					
1	SPL250	2.274-44	2.938	5.328	EY 250-4-31-1
1	SPL250	2.274-44	2.938	5.328	EY 250-4-41-1X
1	SPL90	2.281-44	2.938	4.469	EY 90-4-281-1
1	1610	2.274-44	2.938	4.844	EY 5-4-8021-1
1	1610	2.274-44	2.938	4.844	EY 5-4-9101-1X
1	1710	2.274-44	2.938	5.031	EY 6-4-7961
1	1710	2.274-44	2.938	5.031	EY 6-4-7961-1
1	1710	2.274-44	2.938	5.031	EY 6-4-9161-1X
1	1760	2.274-44	2.938	5.094	EY 6.3-4-1321
1	1760	2.274-44	2.938	5.094	EY 6.3-4-1321-1
1	1760	2.274-44	2.938	5.094	EY 6.3-4-1621-1X
1	1760	2.274-44	2.938	5.094	EY 6.3-4-1621X
1	1810	2.274-44	2.938	5.090	EY 6.5-4-4081-1
1	1810	2.274-44	2.938	5.090	EY 6.5-4-4591-1X

Pos	Series	Spline Data	Hub Dia	* to End of Hub	End Fitting Part Number
23080-T					
1	1810	2.143-41	2.938	3.500	CF 6.5-1-2941
1	1710	2.143-41	2.938	5.190	EY 6-4-7311
1	1710	2.143-41	2.938	5.190	EY 6-4-7311-1
1	1710	2.143-41	2.938	6.125	EY 6-4-7551 <i>High angle yoke</i>
1	1710	2.143-41	2.938	6.125	EY 6-4-7551-1 <i>High angle yoke</i>
1	1710	2.143-41	2.938	5.190	EY 6-4-9171-1X
1	1710	2.143-41	2.938	5.190	EY 6-4-9171X
1	1710	2.143-41	2.938	6.125	EY 6-4-9181-1X <i>High angle yoke</i>
1	1710	2.143-41	2.938	6.125	EY 6-4-9181X <i>High angle yoke</i>
1	1760	2.143-41	2.938	5.250	EY 6.3-4-1061
1	1760	2.143-41	2.938	5.250	EY 6.3-4-1061-1
1	1760	2.143-41	2.938	5.250	EY 6.3-4-1631-1X
1	1810	2.143-41	2.938	5.250	EY 6.5-4-4601-1X
1	1810	2.143-41	2.938	5.250	EY 6.5-4-4601X
1	SPL100	2.143-41	2.938	4.562	EY 100-4-1051-1
1	SPL100	2.143-41	2.938	4.562	EY 100-4-1061-1X
1	SPL140	2.143-41	2.938	5.560	EY 140-4-421-1
1	SPL140	2.143-41	2.938	5.560	EY 140-4-431-1X
1	SPL170	2.143-41	2.938	5.320	EY 170-4-351-1
1	SPL170	2.143-41	2.938	5.320	EY 170-4-361-1X
1	SPL170	2.143-41	2.938	6.680	EY 170-4-371-1 <i>High angle yoke</i>
1	SPL170	2.143-41	2.938	6.680	EY 170-4-381-1X <i>High angle yoke</i>
1	SPL250	2.143-41	2.938	5.490	EY 250-4-131-1
1	SPL250	2.143-41	2.938	5.490	EY 250-4-141-1X
1	SPL90	2.143-41	2.938	4.562	EY 90-4-471-1
1	SPL90	2.143-41	2.938	4.562	EY 90-4-691-1X
1	1550	2.143-41	2.938	4.500	EY 4-4-5581-1
1	1610	2.143-41	2.938	5.250	EY 5-4-7271-1
1	1610	2.143-41	2.938	6.000	EY 5-4-7561
1	1610	2.143-41	2.938	6.000	EY 5-4-7561-1
1	1610	2.143-41	2.938	5.250	EY 5-4-9111-1X
1	1610	2.143-41	2.938	6.000	EY 5-4-9121-1X
1	1610	2.143-41	2.938	6.000	EY 5-4-9121X

Pos	Series	Spline Data	Hub Dia	* to End of Hub	End Fitting Part Number
23082-P, 23082-T					
1	1610	2.143-41	2.938	5.250	EY 5-4-9111-1X
1	1610	2.143-41	2.938	6.000	EY 5-4-9121X
1	1710	2.143-41	2.938	6.125	EY 6-4-9181-1X <i>High angle yoke</i>
1	1710	2.143-41	2.938	6.125	EY 6-4-9181X <i>High angle yoke</i>

Pos	Series	Spline Data	Hub Dia	* to End of Hub	End Fitting Part Number
23085-D					
1	SPL100	2.281-44	2.938	4.469	EY 100-4-1381-1X
1	SPL140	2.274-44	2.938	5.190	EY 140-4-1191-1
1	SPL140	2.274-44	2.938	5.190	EY 140-4-1201-1X
1	SPL140	2.143-41	2.938	5.560	EY 140-4-421-1
1	SPL140	2.143-41	2.938	5.560	EY 140-4-431-1X
1	SPL140	2.274-44	2.938	5.190	EY 140-4-441-1
1	SPL140	2.274-44	2.938	5.190	EY 140-4-451-1X
1	SPL170	2.274-44	2.938	5.094	EY 170-4-21-1
1	SPL170	2.274-44	2.938	5.094	EY 170-4-31-1X
1	SPL170	2.143-41	2.938	5.320	EY 170-4-351-1
1	SPL170	2.143-41	2.938	5.320	EY 170-4-361-1X
1	SPL170	2.143-41	2.938	6.680	EY 170-4-371-1 <i>High angle yoke</i>
1	SPL170	2.143-41	2.938	6.680	EY 170-4-381-1X <i>High angle yoke</i>
1	SPL250	2.143-41	2.938	5.490	EY 250-4-131-1
1	SPL250	2.143-41	2.938	5.490	EY 250-4-141-1X
1	SPL250	2.274-44	2.938	5.328	EY 250-4-31-1
1	SPL250	2.274-44	2.938	5.328	EY 250-4-41-1X
1	SPL90	2.281-44	2.938	4.469	EY 90-4-281-1
1	1610	2.274-44	2.938	4.844	EY 5-4-8021-1
1	1610	2.274-44	2.938	4.844	EY 5-4-9101-1X
1	1710	2.274-44	2.938	5.031	EY 6-4-7961
1	1710	2.274-44	2.938	5.031	EY 6-4-7961-1
1	1710	2.274-44	2.938	5.031	EY 6-4-9161-1X
1	1710	2.274-44	2.938	5.031	EY 6-4-9161X
1	1760	2.274-44	2.938	5.094	EY 6.3-4-1321
1	1760	2.274-44	2.938	5.094	EY 6.3-4-1321-1
1	1760	2.274-44	2.938	5.094	EY 6.3-4-1621-1X
1	1760	2.274-44	2.938	5.094	EY 6.3-4-1621X
1	1810	2.274-44	2.938	5.090	EY 6.5-4-4081-1
1	1810	2.274-44	2.938	5.090	EY 6.5-4-4591-1X

Pos	Series	Spline Data	Hub Dia	* to End of Hub	End Fitting Part Number
23085-P					
1	1810	2.143-41	2.938	3.500	CF 6.5-1-2941
1	1710	2.143-41	2.938	5.190	EY 6-4-7311
1	1710	2.143-41	2.938	5.190	EY 6-4-7311-1
1	1710	2.143-41	2.938	6.125	EY 6-4-7551 <i>High angle yoke</i>
1	1710	2.143-41	2.938	6.125	EY 6-4-7551-1 <i>High angle yoke</i>
1	1710	2.143-41	2.938	5.190	EY 6-4-9171-1X
1	1710	2.143-41	2.938	5.190	EY 6-4-9171X
1	1710	2.143-41	2.938	6.125	EY 6-4-9181-1X <i>High angle yoke</i>
1	1710	2.143-41	2.938	6.125	EY 6-4-9181X <i>High angle yoke</i>
1	1760	2.143-41	2.938	5.250	EY 6.3-4-1061
1	1760	2.143-41	2.938	5.250	EY 6.3-4-1061-1
1	1760	2.274-44	2.938	5.094	EY 6.3-4-1621-1X
1	1760	2.274-44	2.938	5.094	EY 6.3-4-1621X
1	1810	2.274-44	2.938	5.090	EY 6.5-4-4081-1
1	1810	2.274-44	2.938	5.090	EY 6.5-4-4591-1X
1	1810	2.143-41	2.938	5.250	EY 6.5-4-4601-1X
1	1810	2.143-41	2.938	5.250	EY 6.5-4-4601X
1	SPL100	2.143-41	2.938	4.562	EY 100-4-1051-1
1	SPL100	2.143-41	2.938	4.562	EY 100-4-1061-1X
1	SPL140	2.143-41	2.938	5.560	EY 140-4-421-1
1	SPL140	2.143-41	2.938	5.560	EY 140-4-431-1X

Continued on next page

*C/L to End of Hub for EY (End Yoke); Flange Face to End of Hub for CF (Companion Flange)

■ Hub machined for speedometer gear



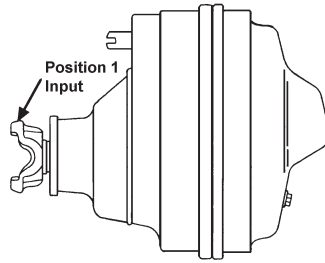

Pos	Series	Spline Data	Hub Dia	* to End of Hub	End Fitting Part Number
-----	--------	-------------	---------	-----------------	-------------------------

23085-P (Continued)

1	SPL170	2.143-41	2.938	5.320	EY 170-4-351-1
1	SPL170	2.143-41	2.938	5.320	EY 170-4-361-1X
1	SPL170	2.143-41	2.938	6.680	EY 170-4-371-1 <i>High angle yoke</i>
1	SPL170	2.143-41	2.938	6.680	EY 170-4-381-1X <i>High angle yoke</i>
1	SPL250	2.143-41	2.938	5.490	EY 250-4-131-1
1	SPL250	2.143-41	2.938	5.490	EY 250-4-141-1X
1	SPL90	2.143-41	2.938	4.562	EY 90-4-471-1
1	SPL90	2.143-41	2.938	4.562	EY 90-4-691-1X
1	1550	2.143-41	2.938	4.500	EY 4-4-5581-1
1	1610	2.143-41	2.938	5.250	EY 5-4-7271-1
1	1610	2.143-41	2.938	6.000	EY 5-4-7561
1	1610	2.143-41	2.938	6.000	EY 5-4-7561-1
1	1610	2.143-41	2.938	5.250	EY 5-4-9111-1X
1	1610	2.143-41	2.938	6.000	EY 5-4-9121-1X
1	1610	2.143-41	2.938	6.000	EY 5-4-9121X

23085-S

1	SPL140	2.274-44	2.938	5.190	EY 140-4-1191-1
1	SPL140	2.274-44	2.938	5.190	EY 140-4-1201-1X
1	SPL140	2.143-41	2.938	5.560	EY 140-4-421-1
1	SPL140	2.143-41	2.938	5.560	EY 140-4-431-1X
1	SPL140	2.274-44	2.938	5.190	EY 140-4-441-1
1	SPL140	2.274-44	2.938	5.190	EY 140-4-451-1X
1	SPL170	2.274-44	2.938	5.094	EY 170-4-31-1X
1	SPL170	2.143-41	2.938	5.320	EY 170-4-351-1
1	SPL170	2.143-41	2.938	5.320	EY 170-4-361-1X
1	SPL170	2.143-41	2.938	6.680	EY 170-4-371-1 <i>High angle yoke</i>
1	SPL170	2.143-41	2.938	6.680	EY 170-4-381-1X <i>High angle yoke</i>
1	SPL250	2.143-41	2.938	5.490	EY 250-4-141-1X
1	SPL250	2.274-44	2.938	5.328	EY 250-4-31-1
1	SPL250	2.274-44	2.938	5.328	EY 250-4-41-1X
1	SPL90	2.281-44	2.938	4.469	EY 90-4-281-1
1	1610	2.274-44	2.938	4.844	EY 5-4-8021-1
1	1610	2.274-44	2.938	4.844	EY 5-4-9101-1X
1	1710	2.274-44	2.938	5.031	EY 6-4-7961
1	1710	2.274-44	2.938	5.031	EY 6-4-7961-1
1	1710	2.274-44	2.938	5.031	EY 6-4-9161-1X
1	1710	2.274-44	2.938	5.031	EY 6-4-9161X
1	1760	2.274-44	2.938	5.094	EY 6.3-4-1321
1	1760	2.274-44	2.938	5.094	EY 6.3-4-1321-1
1	1760	2.274-44	2.938	5.094	EY 6.3-4-1621-1X
1	1760	2.274-44	2.938	5.094	EY 6.3-4-1621X
1	1810	2.274-44	2.938	5.090	EY 6.5-4-4081-1
1	1810	2.274-44	2.938	5.090	EY 6.5-4-4591-1X

Pos	Series	Spline Data	Hub Dia	* to End of Hub	End Fitting Part Number
-----	--------	-------------	---------	-----------------	-------------------------

23085-T

1	1810	2.143-41	2.938	3.500	CF 6.5-1-2941
1	1710	2.143-41	2.938	5.190	EY 6-4-7311
1	1710	2.143-41	2.938	5.190	EY 6-4-7311-1
1	1710	2.143-41	2.938	6.125	EY 6-4-7551 <i>High angle yoke</i>
1	1710	2.143-41	2.938	6.125	EY 6-4-7551-1 <i>High angle yoke</i>
1	1710	2.143-41	2.938	5.190	EY 6-4-9171-1X
1	1710	2.143-41	2.938	5.190	EY 6-4-9171X
1	1710	2.143-41	2.938	6.125	EY 6-4-9181-1X <i>High angle yoke</i>
1	1710	2.143-41	2.938	6.125	EY 6-4-9181X <i>High angle yoke</i>
1	1760	2.143-41	2.938	5.250	EY 6.3-4-1061
1	1760	2.143-41	2.938	5.250	EY 6.3-4-1061-1
1	1760	2.274-44	2.938	5.094	EY 6.3-4-1621-1X
1	1760	2.274-44	2.938	5.094	EY 6.3-4-1621X
1	1810	2.274-44	2.938	5.090	EY 6.5-4-4081-1
1	1810	2.274-44	2.938	5.090	EY 6.5-4-4591-1X
1	1810	2.143-41	2.938	5.250	EY 6.5-4-4601-1X
1	1810	2.143-41	2.938	5.250	EY 6.5-4-4601X
1	SPL100	2.143-41	2.938	4.562	EY 100-4-1051-1
1	SPL100	2.143-41	2.938	4.562	EY 100-4-1061-1X
1	SPL140	2.143-41	2.938	5.560	EY 140-4-421-1
1	SPL140	2.143-41	2.938	5.560	EY 140-4-431-1X
1	SPL170	2.143-41	2.938	5.320	EY 170-4-351-1
1	SPL170	2.143-41	2.938	5.320	EY 170-4-361-1X
1	SPL170	2.143-41	2.938	6.680	EY 170-4-371-1 <i>High angle yoke</i>
1	SPL170	2.143-41	2.938	6.680	EY 170-4-381-1X <i>High angle yoke</i>
1	SPL250	2.143-41	2.938	5.490	EY 250-4-131-1
1	SPL250	2.143-41	2.938	5.490	EY 250-4-141-1X
1	SPL90	2.143-41	2.938	4.562	EY 90-4-471-1
1	SPL90	2.143-41	2.938	4.562	EY 90-4-691-1X
1	1550	2.143-41	2.938	4.500	EY 4-4-5581-1
1	1610	2.143-41	2.938	5.250	EY 5-4-7271-1
1	1610	2.143-41	2.938	6.000	EY 5-4-7561
1	1610	2.143-41	2.938	6.000	EY 5-4-7561-1
1	1610	2.143-41	2.938	5.250	EY 5-4-9111-1X
1	1610	2.143-41	2.938	6.000	EY 5-4-9121-1X
1	1610	2.143-41	2.938	6.000	EY 5-4-9121X

23090-S

1	SPL100	2.281-44	2.938	4.469	EY 100-4-1381-1X
1	SPL140	2.274-44	2.938	5.190	EY 140-4-1191-1
1	SPL140	2.274-44	2.938	5.190	EY 140-4-441-1
1	1610	2.274-44	2.938	4.844	EY 5-4-8021-1
1	1610	2.274-44	2.938	4.844	EY 5-4-9101-1X
1	1710	2.274-44	2.938	5.031	EY 6-4-7961
1	1710	2.274-44	2.938	5.031	EY 6-4-7961-1

*C/L to End of Hub for EY (End Yoke); Flange Face to End of Hub for CF (Companion Flange)

■ Hub machined for speedometer gear



Pos	Series	Spline Data	Hub Dia	* to End of Hub	End Fitting Part Number
23090-S (Continued)					
1	1710	2.274-44	2.938	5.031	EY 6-4-9161-1X
1	1710	2.274-44	2.938	5.031	EY 6-4-9161X
1	1760	2.274-44	2.938	5.094	EY 6.3-4-1321
1	1760	2.274-44	2.938	5.094	EY 6.3-4-1321-1
1	1760	2.274-44	2.938	5.094	EY 6.3-4-1621-1X
1	1760	2.274-44	2.938	5.094	EY 6.3-4-1621X
1	1810	2.274-44	2.938	5.090	EY 6.5-4-4081-1
1	1810	2.274-44	2.938	5.090	EY 6.5-4-4591-1X

23105-A					
1	1760	2.274-44	2.938	5.094	EY 6.3-4-1321

23105-C					
1	1610	2.274-44	2.938	4.844	EY 5-4-8031-1X
1	1710	2.274-44	2.938	5.031	EY 6-4-7961
1	1710	2.274-44	2.938	5.031	EY 6-4-7961-1
1	1710	2.274-44	2.938	5.031	EY 6-4-7971-1X
1	1710	2.274-44	2.938	5.031	EY 6-4-7971X
1	1760	2.274-44	2.938	5.094	EY 6.3-4-1321
1	1760	2.274-44	2.938	5.094	EY 6.3-4-1321-1
1	1760	2.274-44	2.938	5.094	EY 6.3-4-1331-1X
1	1760	2.274-44	2.938	5.094	EY 6.3-4-1331X
1	1760	2.274-44	2.938	5.094	EY 6.3-4-1621-1X
1	1760	2.274-44	2.938	5.094	EY 6.3-4-1621X
1	1810	2.274-44	2.938	5.090	EY 6.5-4-4091-1X
1	1810	2.274-44	2.938	5.090	EY 6.5-4-4591-1X

23105-D, 23105-S					
1	SPL100	2.281-44	2.938	4.469	EY 100-4-1381-1X
1	SPL140	2.274-44	2.938	5.190	EY 140-4-1191-1
1	SPL140	2.274-44	2.938	5.190	EY 140-4-1201-1X
1	SPL140	2.143-41	2.938	5.560	EY 140-4-421-1
1	SPL140	2.143-41	2.938	5.560	EY 140-4-431-1X
1	SPL140	2.274-44	2.938	5.190	EY 140-4-441-1
1	SPL140	2.274-44	2.938	5.190	EY 140-4-451-1X
1	SPL170	2.274-44	2.938	5.094	EY 170-4-21-1
1	SPL170	2.274-44	2.938	5.094	EY 170-4-31-1X
1	SPL170	2.143-41	2.938	5.320	EY 170-4-351-1
1	SPL170	2.143-41	2.938	5.320	EY 170-4-361-1X
1	SPL170	2.143-41	2.938	6.680	EY 170-4-371-1
					<i>High angle yoke</i>
1	SPL170	2.143-41	2.938	6.680	EY 170-4-381-1X
					<i>High angle yoke</i>
1	SPL250	2.143-41	2.938	5.490	EY 250-4-131-1
1	SPL250	2.143-41	2.938	5.490	EY 250-4-141-1X
1	SPL250	2.274-44	2.938	5.328	EY 250-4-31-1
1	SPL250	2.274-44	2.938	5.328	EY 250-4-41-1X
1	SPL90	2.281-44	2.938	4.469	EY 90-4-281-1
1	1610	2.274-44	2.938	4.844	EY 5-4-8021-1
1	1610	2.274-44	2.938	4.844	EY 5-4-8031-1X
1	1610	2.274-44	2.938	4.844	EY 5-4-9101-1X
1	1710	2.274-44	2.938	5.031	EY 6-4-7961
1	1710	2.274-44	2.938	5.031	EY 6-4-7961-1
1	1710	2.274-44	2.938	5.031	EY 6-4-7971-1X
1	1710	2.274-44	2.938	5.031	EY 6-4-7971X
1	1710	2.274-44	2.938	5.031	EY 6-4-9161-1X
1	1710	2.274-44	2.938	5.031	EY 6-4-9161X
1	1760	2.274-44	2.938	5.094	EY 6.3-4-1321
1	1760	2.274-44	2.938	5.094	EY 6.3-4-1321-1
1	1760	2.274-44	2.938	5.094	EY 6.3-4-1331-1X

Pos	Series	Spline Data	Hub Dia	* to End of Hub	End Fitting Part Number
23105-D, 23105-S (Continued)					
1	1760	2.274-44	2.938	5.094	EY 6.3-4-1331X
1	1760	2.274-44	2.938	5.094	EY 6.3-4-1621-1X
1	1760	2.274-44	2.938	5.094	EY 6.3-4-1621X
1	1810	2.274-44	2.938	5.090	EY 6.5-4-4081-1
1	1810	2.274-44	2.938	5.090	EY 6.5-4-4091-1X
1	1810	2.274-44	2.938	5.090	EY 6.5-4-4591-1X

23121					
1	1610	2.149-16	2.938	6.250	EY 5-4-5161-1X
1	1610	2.149-16	2.938	6.250	EY 5-4-5161X
					<i>High angle yoke</i>
1	1710	2.149-16	2.938	5.500	EY 6-4-4171-1X
1	1710	2.149-16	2.938	5.500	EY 6-4-4171X
1	1760	2.149-16	2.938	5.812	EY 6.3-4-141
1	1760	2.149-16	2.938	5.812	EY 6.3-4-141-1
1	1760	2.149-16	2.938	5.812	EY 6.3-4-251-1X
1	1760	2.149-16	2.938	5.812	EY 6.3-4-251X
1	1810	2.149-16	2.938	5.812	EY 6.5-4-2401-1X
1	1810	2.149-16	2.938	5.812	EY 6.5-4-2401X

23207					
1	SPL100	2.143-41	2.938	4.562	EY 100-4-1061-1X
1	SPL90	2.143-41	2.938	4.562	EY 90-4-471-1

23221					
1	1760	2.149-16	2.938	5.812	EY 6.3-4-141
1	1760	2.149-16	2.938	5.812	EY 6.3-4-141-1

23421					
1	1610	2.149-16	2.938	6.250	EY 5-4-5161-1X
1	1610	2.149-16	2.938	6.250	EY 5-4-5161X
					<i>High angle yoke</i>
1	1710	2.149-16	2.938	5.500	EY 6-4-4171-1X
1	1710	2.149-16	2.938	5.500	EY 6-4-4171X
1	1760	2.149-16	2.938	5.812	EY 6.3-4-251-1X
1	1760	2.149-16	2.938	5.812	EY 6.3-4-251X
1	1810	2.149-16	2.938	5.812	EY 6.5-4-2291-1
1	1810	2.149-16	2.938	5.812	EY 6.5-4-2291-1X
1	1810	2.149-16	2.938	5.812	EY 6.5-4-2401-1X
1	1810	2.149-16	2.938	5.812	EY 6.5-4-2401X

26080-A, 26080-D					
1	SPL100	2.281-44	2.938	4.469	EY 100-4-1381-1X
1	SPL140	2.274-44	2.938	5.190	EY 140-4-1191-1
1	SPL140	2.274-44	2.938	5.190	EY 140-4-1201-1X
1	SPL140	2.143-41	2.938	5.560	EY 140-4-421-1
1	SPL140	2.143-41	2.938	5.560	EY 140-4-431-1X
1	SPL140	2.274-44	2.938	5.190	EY 140-4-441-1
1	SPL140	2.274-44	2.938	5.190	EY 140-4-451-1X
1	SPL170	2.274-44	2.938	5.094	EY 170-4-21-1
1	SPL170	2.274-44	2.938	5.094	EY 170-4-31-1X
1	SPL170	2.143-41	2.938	5.320	EY 170-4-351-1
1	SPL170	2.143-41	2.938	5.320	EY 170-4-361-1X
1	SPL170	2.143-41	2.938	6.680	EY 170-4-371-1
					<i>High angle yoke</i>
1	SPL170	2.143-41	2.938	6.680	EY 170-4-381-1X
					<i>High angle yoke</i>
1	SPL250	2.143-41	2.938	5.490	EY 250-4-131-1
1	SPL250	2.143-41	2.938	5.490	EY 250-4-141-1X
1	SPL250	2.274-44	2.938	5.328	EY 250-4-31-1
1	SPL250	2.274-44	2.938	5.328	EY 250-4-41-1X

Continued on next page

*C/L to End of Hub for EY (End Yoke); Flange Face to End of Hub for CF (Companion Flange)

■ Hub machined for speedometer gear



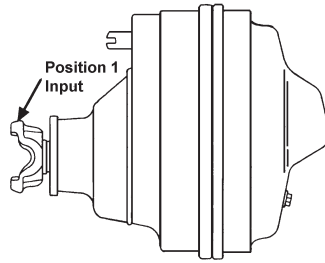

Pos	Series	Spline Data	Hub Dia	* to End of Hub	End Fitting Part Number
-----	--------	-------------	---------	-----------------	-------------------------

26080-A, 26080-D (Continued)

1	SPL90	2.281-44	2.938	4.469	EY 90-4-281-1
1	1610	2.274-44	2.938	4.844	EY 5-4-8021-1
1	1610	2.274-44	2.938	4.844	EY 5-4-9101-1X
1	1710	2.274-44	2.938	5.031	EY 6-4-7961
1	1710	2.274-44	2.938	5.031	EY 6-4-9161-1X
1	1710	2.274-44	2.938	5.031	EY 6-4-9161X
1	1760	2.274-44	2.938	5.094	EY 6.3-4-1321
1	1760	2.274-44	2.938	5.094	EY 6.3-4-1321-1
1	1760	2.274-44	2.938	5.094	EY 6.3-4-1621-1X
1	1760	2.274-44	2.938	5.094	EY 6.3-4-1621X
1	1810	2.274-44	2.938	5.090	EY 6.5-4-4081-1

26080-P

1	1810	2.143-41	2.938	3.500	CF 6.5-1-2941
1	1710	2.143-41	2.938	5.190	EY 6-4-7311
1	1710	2.143-41	2.938	5.190	EY 6-4-7311-1
1	1710	2.143-41	2.938	6.125	EY 6-4-7551
					<i>High angle yoke</i>
1	1710	2.143-41	2.938	6.125	EY 6-4-7551-1
					<i>High angle yoke</i>
1	1710	2.143-41	2.938	5.190	EY 6-4-9171-1X
1	1710	2.143-41	2.938	5.190	EY 6-4-9171X
1	1710	2.143-41	2.938	6.125	EY 6-4-9181-1X
					<i>High angle yoke</i>
1	1710	2.143-41	2.938	6.125	EY 6-4-9181X
					<i>High angle yoke</i>
1	1760	2.143-41	2.938	5.250	EY 6.3-4-1061
1	1760	2.143-41	2.938	5.250	EY 6.3-4-1061-1
1	1760	2.143-41	2.938	5.250	EY 6.3-4-1631-1X
1	1810	2.143-41	2.938	5.250	EY 6.5-4-4601-1X
1	1810	2.143-41	2.938	5.250	EY 6.5-4-4601X
1	SPL100	2.143-41	2.938	4.562	EY 100-4-1051-1
1	SPL100	2.143-41	2.938	4.562	EY 100-4-1061-1X
1	SPL140	2.143-41	2.938	5.560	EY 140-4-421-1
1	SPL140	2.143-41	2.938	5.560	EY 140-4-431-1X
1	SPL170	2.143-41	2.938	5.320	EY 170-4-351-1
1	SPL170	2.143-41	2.938	5.320	EY 170-4-361-1X
1	SPL170	2.143-41	2.938	6.680	EY 170-4-371-1
					<i>High angle yoke</i>
1	SPL170	2.143-41	2.938	6.680	EY 170-4-381-1X
					<i>High angle yoke</i>
1	SPL250	2.143-41	2.938	5.490	EY 250-4-131-1
1	SPL250	2.143-41	2.938	5.490	EY 250-4-141-1X
1	SPL90	2.143-41	2.938	4.562	EY 90-4-471-1
1	SPL90	2.143-41	2.938	4.562	EY 90-4-691-1X
1	1550	2.143-41	2.938	4.500	EY 4-4-5581-1
1	1610	2.143-41	2.938	5.250	EY 5-4-7271-1
1	1610	2.143-41	2.938	6.000	EY 5-4-7561
1	1610	2.143-41	2.938	6.000	EY 5-4-7561-1
1	1610	2.143-41	2.938	5.250	EY 5-4-9111-1X
1	1610	2.143-41	2.938	6.000	EY 5-4-9121-1X
1	1610	2.143-41	2.938	6.000	EY 5-4-9121X

Pos	Series	Spline Data	Hub Dia	* to End of Hub	End Fitting Part Number
-----	--------	-------------	---------	-----------------	-------------------------

26080-S

1	SPL100	2.281-44	2.938	4.469	EY 100-4-1381-1X
1	SPL140	2.274-44	2.938	5.190	EY 140-4-1191-1
1	SPL140	2.274-44	2.938	5.190	EY 140-4-1201-1X
1	SPL140	2.143-41	2.938	5.560	EY 140-4-421-1
1	SPL140	2.143-41	2.938	5.560	EY 140-4-431-1X
1	SPL140	2.274-44	2.938	5.190	EY 140-4-441-1
1	SPL140	2.274-44	2.938	5.190	EY 140-4-451-1X
1	SPL170	2.274-44	2.938	5.094	EY 170-4-21-1
1	SPL170	2.274-44	2.938	5.094	EY 170-4-31-1X
1	SPL170	2.143-41	2.938	5.320	EY 170-4-351-1
1	SPL170	2.143-41	2.938	5.320	EY 170-4-361-1X
1	SPL170	2.143-41	2.938	6.680	EY 170-4-371-1
					<i>High angle yoke</i>
1	SPL170	2.143-41	2.938	6.680	EY 170-4-381-1X
					<i>High angle yoke</i>
1	SPL250	2.143-41	2.938	5.490	EY 250-4-131-1
1	SPL250	2.143-41	2.938	5.490	EY 250-4-141-1X
1	SPL250	2.274-44	2.938	5.328	EY 250-4-31-1
1	SPL250	2.274-44	2.938	5.328	EY 250-4-41-1X
1	SPL90	2.281-44	2.938	4.469	EY 90-4-281-1
1	1610	2.274-44	2.938	4.844	EY 5-4-8021-1
1	1610	2.274-44	2.938	4.844	EY 5-4-9101-1X
1	1710	2.274-44	2.938	5.031	EY 6-4-7961
1	1710	2.274-44	2.938	5.031	EY 6-4-7961-1
1	1710	2.274-44	2.938	5.031	EY 6-4-9161-1X
1	1710	2.274-44	2.938	5.031	EY 6-4-9161X
1	1760	2.274-44	2.938	5.094	EY 6.3-4-1321
1	1760	2.274-44	2.938	5.094	EY 6.3-4-1621-1X
1	1760	2.274-44	2.938	5.094	EY 6.3-4-1621X
1	1810	2.274-44	2.938	5.090	EY 6.5-4-4081-1

26080-T

1	1810	2.143-41	2.938	3.500	CF 6.5-1-2941
1	1710	2.143-41	2.938	5.190	EY 6-4-7311
1	1710	2.143-41	2.938	5.190	EY 6-4-7311-1
1	1710	2.143-41	2.938	6.125	EY 6-4-7551
					<i>High angle yoke</i>
1	1710	2.143-41	2.938	6.125	EY 6-4-7551-1
					<i>High angle yoke</i>
1	1710	2.143-41	2.938	5.190	EY 6-4-9171-1X
1	1710	2.143-41	2.938	5.190	EY 6-4-9171X
1	1710	2.143-41	2.938	6.125	EY 6-4-9181-1X
					<i>High angle yoke</i>
1	1710	2.143-41	2.938	6.125	EY 6-4-9181X
					<i>High angle yoke</i>
1	1760	2.143-41	2.938	5.250	EY 6.3-4-1061
1	1760	2.143-41	2.938	5.250	EY 6.3-4-1061-1
1	1760	2.143-41	2.938	5.250	EY 6.3-4-1631-1X
1	1810	2.143-41	2.938	5.250	EY 6.5-4-4601-1X
1	1810	2.143-41	2.938	5.250	EY 6.5-4-4601X

*C/L to End of Hub for EY (End Yoke); Flange Face to End of Hub for CF (Companion Flange)

■ Hub machined for speedometer gear



Pos	Series	Spline Data	Hub Dia	* to End of Hub	End Fitting Part Number
26080-T (Continued)					
1	SPL100	2.143-41	2.938	4.562	EY 100-4-1051-1
1	SPL100	2.143-41	2.938	4.562	EY 100-4-1061-1X
1	SPL140	2.143-41	2.938	5.560	EY 140-4-421-1
1	SPL140	2.143-41	2.938	5.560	EY 140-4-431-1X
1	SPL170	2.143-41	2.938	5.320	EY 170-4-351-1
1	SPL170	2.143-41	2.938	5.320	EY 170-4-361-1X
1	SPL170	2.143-41	2.938	6.680	EY 170-4-371-1
					<i>High angle yoke</i>
1	SPL170	2.143-41	2.938	6.680	EY 170-4-381-1X
					<i>High angle yoke</i>
1	SPL250	2.143-41	2.938	5.490	EY 250-4-131-1
1	SPL250	2.143-41	2.938	5.490	EY 250-4-141-1X
1	SPL90	2.143-41	2.938	4.562	EY 90-4-471-1
1	SPL90	2.143-41	2.938	4.562	EY 90-4-691-1X
1	1550	2.143-41	2.938	4.500	EY 4-4-5581-1
1	1610	2.143-41	2.938	5.250	EY 5-4-7271-1
1	1610	2.143-41	2.938	6.000	EY 5-4-7561
1	1610	2.143-41	2.938	6.000	EY 5-4-7561-1
1	1610	2.143-41	2.938	5.250	EY 5-4-9111-1X
1	1610	2.143-41	2.938	6.000	EY 5-4-9121-1X
1	1610	2.143-41	2.938	6.000	EY 5-4-9121X
26085					
1	1550	2.143-41	2.938	4.500	EY 4-4-5701-1X
1	1610	2.143-41	2.938	5.250	EY 5-4-7311-1X
1	1710	2.143-41	2.938	5.190	EY 6-4-7321-1X
1	1710	2.143-41	2.938	6.125	EY 6-4-7561X
					<i>High angle yoke</i>
1	1760	2.143-41	2.938	5.250	EY 6.3-4-1071-1X
1	1810	2.143-41	2.938	5.250	EY 6.5-4-3691-1X
26085-A					
1	1710	2.274-44	2.938	5.031	EY 6-4-7961
1	1710	2.274-44	2.938	5.031	EY 6-4-7961-1
1	1810	2.274-44	2.938	5.090	EY 6.5-4-4591-1X
26085-D					
1	SPL100	2.281-44	2.938	4.469	EY 100-4-1381-1X
1	SPL140	2.274-44	2.938	5.190	EY 140-4-1191-1
1	SPL140	2.274-44	2.938	5.190	EY 140-4-1201-1X
1	SPL140	2.143-41	2.938	5.560	EY 140-4-431-1X
1	SPL140	2.274-44	2.938	5.190	EY 140-4-441-1
1	SPL140	2.274-44	2.938	5.190	EY 140-4-451-1X
1	SPL170	2.274-44	2.938	5.094	EY 170-4-21-1
1	SPL170	2.274-44	2.938	5.094	EY 170-4-31-1X
1	SPL170	2.143-41	2.938	5.320	EY 170-4-351-1
1	SPL170	2.143-41	2.938	5.320	EY 170-4-361-1X
1	SPL170	2.143-41	2.938	6.680	EY 170-4-371-1
					<i>High angle yoke</i>
1	SPL170	2.143-41	2.938	6.680	EY 170-4-381-1X
					<i>High angle yoke</i>
1	SPL250	2.143-41	2.938	5.490	EY 250-4-141-1X
1	SPL250	2.274-44	2.938	5.328	EY 250-4-31-1
1	SPL250	2.274-44	2.938	5.328	EY 250-4-41-1X
1	SPL90	2.281-44	2.938	4.469	EY 90-4-281-1
1	1610	2.274-44	2.938	4.844	EY 5-4-8021-1
1	1610	2.274-44	2.938	4.844	EY 5-4-9101-1X
1	1710	2.274-44	2.938	5.031	EY 6-4-7961
1	1710	2.274-44	2.938	5.031	EY 6-4-7961-1
1	1710	2.274-44	2.938	5.031	EY 6-4-9161-1X
1	1710	2.274-44	2.938	5.031	EY 6-4-9161X

Pos	Series	Spline Data	Hub Dia	* to End of Hub	End Fitting Part Number
26085-D (Continued)					
1	1760	2.274-44	2.938	5.094	EY 6.3-4-1321
1	1760	2.274-44	2.938	5.094	EY 6.3-4-1321-1
1	1760	2.274-44	2.938	5.094	EY 6.3-4-1621-1X
1	1760	2.274-44	2.938	5.094	EY 6.3-4-1621X
1	1810	2.274-44	2.938	5.090	EY 6.5-4-4081-1
1	1810	2.274-44	2.938	5.090	EY 6.5-4-4591-1X
26085-P					
1	1810	2.143-41	2.938	3.500	CF 6.5-1-2941
1	1710	2.143-41	2.938	5.190	EY 6-4-7311
1	1710	2.143-41	2.938	5.190	EY 6-4-7311-1
1	1710	2.143-41	2.938	6.125	EY 6-4-7551
					<i>High angle yoke</i>
1	1710	2.143-41	2.938	6.125	EY 6-4-7551-1
					<i>High angle yoke</i>
1	1710	2.143-41	2.938	5.190	EY 6-4-9171-1X
1	1710	2.143-41	2.938	5.190	EY 6-4-9171X
1	1710	2.143-41	2.938	6.125	EY 6-4-9181-1X
					<i>High angle yoke</i>
1	1710	2.143-41	2.938	6.125	EY 6-4-9181X
					<i>High angle yoke</i>
1	1760	2.143-41	2.938	5.250	EY 6.3-4-1061
1	1760	2.143-41	2.938	5.250	EY 6.3-4-1061-1
1	1760	2.143-41	2.938	5.250	EY 6.3-4-1631-1X
1	1810	2.143-41	2.938	5.250	EY 6.5-4-4601-1X
1	1810	2.143-41	2.938	5.250	EY 6.5-4-4601X
1	SPL100	2.143-41	2.938	4.562	EY 100-4-1051-1
1	SPL100	2.143-41	2.938	4.562	EY 100-4-1061-1X
1	SPL140	2.143-41	2.938	5.560	EY 140-4-421-1
1	SPL140	2.143-41	2.938	5.560	EY 140-4-431-1X
1	SPL170	2.143-41	2.938	5.320	EY 170-4-351-1
1	SPL170	2.143-41	2.938	5.320	EY 170-4-361-1X
1	SPL170	2.143-41	2.938	6.680	EY 170-4-371-1
					<i>High angle yoke</i>
1	SPL170	2.143-41	2.938	6.680	EY 170-4-381-1X
					<i>High angle yoke</i>
1	SPL250	2.143-41	2.938	5.490	EY 250-4-131-1
1	SPL250	2.143-41	2.938	5.490	EY 250-4-141-1X
1	SPL90	2.143-41	2.938	4.562	EY 90-4-471-1
1	SPL90	2.143-41	2.938	4.562	EY 90-4-691-1X
1	1550	2.143-41	2.938	4.500	EY 4-4-5581-1
1	1610	2.143-41	2.938	5.250	EY 5-4-7271-1
1	1610	2.143-41	2.938	6.000	EY 5-4-7561
1	1610	2.143-41	2.938	6.000	EY 5-4-7561-1
1	1610	2.143-41	2.938	5.250	EY 5-4-9111-1X
1	1610	2.143-41	2.938	6.000	EY 5-4-9121-1X
1	1610	2.143-41	2.938	6.000	EY 5-4-9121X
26085-S					
1	SPL100	2.281-44	2.938	4.469	EY 100-4-1381-1X
1	SPL140	2.274-44	2.938	5.190	EY 140-4-1191-1
1	SPL140	2.274-44	2.938	5.190	EY 140-4-1201-1X
1	SPL140	2.143-41	2.938	5.560	EY 140-4-431-1X
1	SPL140	2.274-44	2.938	5.190	EY 140-4-441-1
1	SPL140	2.274-44	2.938	5.190	EY 140-4-451-1X
1	SPL170	2.274-44	2.938	5.094	EY 170-4-31-1X
1	SPL170	2.143-41	2.938	5.320	EY 170-4-351-1
1	SPL170	2.143-41	2.938	5.320	EY 170-4-361-1X

Continued on next page

*C/L to End of Hub for EY (End Yoke); Flange Face to End of Hub for CF (Companion Flange)

■ Hub machined for speedometer gear



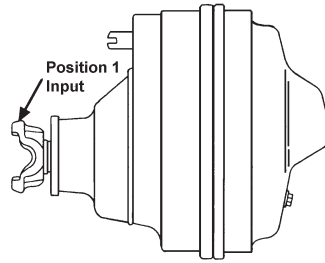

Pos	Series	Spline Data	Hub Dia	* to End of Hub	End Fitting Part Number
26085-S (Continued)					
1	SPL170	2.143-41	2.938	6.680	EY 170-4-371-1 <i>High angle yoke</i>
1	SPL170	2.143-41	2.938	6.680	EY 170-4-381-1X <i>High angle yoke</i>
1	SPL250	2.143-41	2.938	5.490	EY 250-4-131-1
1	SPL250	2.143-41	2.938	5.490	EY 250-4-141-1X
1	SPL250	2.274-44	2.938	5.328	EY 250-4-31-1
1	SPL250	2.274-44	2.938	5.328	EY 250-4-41-1X
1	SPL90	2.281-44	2.938	4.469	EY 90-4-281-1
1	1610	2.274-44	2.938	4.844	EY 5-4-8021-1
1	1610	2.274-44	2.938	4.844	EY 5-4-9101-1X
1	1710	2.274-44	2.938	5.031	EY 6-4-7961
1	1710	2.274-44	2.938	5.031	EY 6-4-7961-1
1	1710	2.274-44	2.938	5.031	EY 6-4-9161-1X
1	1710	2.274-44	2.938	5.031	EY 6-4-9161X
1	1760	2.274-44	2.938	5.094	EY 6.3-4-1321
1	1760	2.274-44	2.938	5.094	EY 6.3-4-1321-1
1	1760	2.274-44	2.938	5.094	EY 6.3-4-1621-1X
1	1760	2.274-44	2.938	5.094	EY 6.3-4-1621X
1	1810	2.274-44	2.938	5.090	EY 6.5-4-4081-1
1	1810	2.274-44	2.938	5.090	EY 6.5-4-4591-1X

26085-T					
1	1810	2.143-41	2.938	3.500	CF 6.5-1-2941
1	1710	2.143-41	2.938	5.190	EY 6-4-7311
1	1710	2.143-41	2.938	5.190	EY 6-4-7311-1
1	1710	2.143-41	2.938	5.190	EY 6-4-7321-1X
1	1710	2.143-41	2.938	6.125	EY 6-4-7551 <i>High angle yoke</i>
1	1710	2.143-41	2.938	6.125	EY 6-4-7551-1 <i>High angle yoke</i>
1	1710	2.143-41	2.938	5.190	EY 6-4-9171-1X
1	1710	2.143-41	2.938	5.190	EY 6-4-9171X
1	1710	2.143-41	2.938	6.125	EY 6-4-9181-1X <i>High angle yoke</i>
1	1710	2.143-41	2.938	6.125	EY 6-4-9181X <i>High angle yoke</i>
1	1760	2.143-41	2.938	5.250	EY 6.3-4-1061
1	1760	2.143-41	2.938	5.250	EY 6.3-4-1061-1
1	1760	2.143-41	2.938	5.250	EY 6.3-4-1071-1X
1	1760	2.143-41	2.938	5.250	EY 6.3-4-1631-1X
1	1810	2.143-41	2.938	5.250	EY 6.5-4-4601-1X
1	1810	2.143-41	2.938	5.250	EY 6.5-4-4601X
1	1810	2.143-41	2.938	5.250	EY 6.5-4-3691X
1	SPL100	2.143-41	2.938	4.562	EY 100-4-1051-1
1	SPL100	2.143-41	2.938	4.562	EY 100-4-1061-1X
1	SPL140	2.143-41	2.938	5.560	EY 140-4-421-1
1	SPL140	2.143-41	2.938	5.560	EY 140-4-431-1X
1	SPL170	2.143-41	2.938	5.320	EY 170-4-351-1
1	SPL170	2.143-41	2.938	5.320	EY 170-4-361-1X
1	SPL170	2.143-41	2.938	6.680	EY 170-4-371-1 <i>High angle yoke</i>

Pos	Series	Spline Data	Hub Dia	* to End of Hub	End Fitting Part Number
26085-T (Continued)					
1	SPL170	2.143-41	2.938	6.680	EY 170-4-381-1X <i>High angle yoke</i>
1	SPL250	2.143-41	2.938	5.490	EY 250-4-131-1
1	SPL250	2.143-41	2.938	5.490	EY 250-4-141-1X
1	SPL70	2.143-41	2.938	4.555	EY 70-4-141-1
1	SPL70	2.143-41	2.938	4.555	EY 70-4-151-1X
1	SPL90	2.143-41	2.938	4.562	EY 90-4-471-1
1	SPL90	2.143-41	2.938	4.562	EY 90-4-691-1X
1	1550	2.143-41	2.938	4.500	EY 4-4-5581-1
1	1610	2.143-41	2.938	5.250	EY 5-4-7271-1
1	1610	2.143-41	2.938	6.000	EY 5-4-7561
1	1610	2.143-41	2.938	6.000	EY 5-4-7561-1
1	1610	2.143-41	2.938	5.250	EY 5-4-9111-1X
1	1610	2.143-41	2.938	6.000	EY 5-4-9121-1X
1	1610	2.143-41	2.938	6.000	EY 5-4-9121X
1	1760	2.143-41	2.938	5.250	EY 6.3-4-1071X

26105-D					
1	SPL100	2.281-44	2.938	4.469	EY 100-4-1381-1X
1	SPL140	2.274-44	2.938	5.190	EY 140-4-1191-1
1	SPL140	2.274-44	2.938	5.190	EY 140-4-441-1
1	SPL140	2.274-44	2.938	5.190	EY 140-4-451-1X
1	SPL170	2.274-44	2.938	5.094	EY 170-4-21-1
1	SPL170	2.274-44	2.938	5.094	EY 170-4-31-1X
1	SPL250	2.274-44	2.938	5.328	EY 250-4-31-1
1	SPL250	2.274-44	2.938	5.328	EY 250-4-41-1X
1	SPL90	2.281-44	2.938	4.469	EY 90-4-281-1
1	1610	2.274-44	2.938	4.844	EY 5-4-8021-1
1	1610	2.274-44	2.938	4.844	EY 5-4-9101-1X
1	1710	2.274-44	2.938	5.031	EY 6-4-7961
1	1710	2.274-44	2.938	5.031	EY 6-4-7961-1
1	1710	2.274-44	2.938	5.031	EY 6-4-9161-1X
1	1710	2.274-44	2.938	5.031	EY 6-4-9161X
1	1760	2.274-44	2.938	5.094	EY 6.3-4-1321
1	1760	2.274-44	2.938	5.094	EY 6.3-4-1321-1
1	1760	2.274-44	2.938	5.094	EY 6.3-4-1621-1X
1	1760	2.274-44	2.938	5.094	EY 6.3-4-1621X
1	1810	2.274-44	2.938	5.090	EY 6.5-4-4081-1
1	1810	2.274-44	2.938	5.090	EY 6.5-4-4591-1X

26105-S					
1	SPL100	2.281-44	2.938	4.469	EY 100-4-1381-1X
1	SPL140	2.274-44	2.938	5.190	EY 140-4-1191-1
1	SPL140	2.274-44	2.938	5.190	EY 140-4-1201-1X
1	SPL140	2.143-41	2.938	5.560	EY 140-4-421-1
1	SPL140	2.143-41	2.938	5.560	EY 140-4-431-1X
1	SPL140	2.274-44	2.938	5.190	EY 140-4-441-1
1	SPL140	2.274-44	2.938	5.190	EY 140-4-451-1X
1	SPL170	2.274-44	2.938	5.094	EY 170-4-21-1
1	SPL170	2.274-44	2.938	5.094	EY 170-4-31-1X

*C/L to End of Hub for EY (End Yoke); Flange Face to End of Hub for CF (Companion Flange)

■ Hub machined for speedometer gear



Pos	Series	Spline Data	Hub Dia	* to End of Hub	End Fitting Part Number
26105-S (Continued)					
1	SPL170	2.143-41	2.938	5.320	EY 170-4-351-1
1	SPL170	2.143-41	2.938	5.320	EY 170-4-361-1X
1	SPL170	2.143-41	2.938	6.680	EY 170-4-371-1 <i>High angle yoke</i>
1	SPL170	2.143-41	2.938	6.680	EY 170-4-381-1X <i>High angle yoke</i>
1	SPL250	2.143-41	2.938	5.490	EY 250-4-131-1
1	SPL250	2.143-41	2.938	5.490	EY 250-4-141-1X
1	SPL250	2.274-44	2.938	5.328	EY 250-4-31-1
1	SPL250	2.274-44	2.938	5.328	EY 250-4-41-1X
1	SPL90	2.281-44	2.938	4.469	EY 90-4-281-1
1	1610	2.274-44	2.938	4.844	EY 5-4-8021-1
1	1610	2.274-44	2.938	4.844	EY 5-4-9101-1X
1	1710	2.274-44	2.938	5.031	EY 6-4-7961
1	1710	2.274-44	2.938	5.031	EY 6-4-7961-1
1	1710	2.274-44	2.938	5.031	EY 6-4-9161-1X
1	1710	2.274-44	2.938	5.031	EY 6-4-9161X
1	1760	2.274-44	2.938	5.094	EY 6.3-4-1321
1	1760	2.274-44	2.938	5.094	EY 6.3-4-1321-1
1	1760	2.274-44	2.938	5.094	EY 6.3-4-1621-1X
1	1760	2.274-44	2.938	5.094	EY 6.3-4-1621X
1	1810	2.274-44	2.938	5.090	EY 6.5-4-4081-1
1	1810	2.274-44	2.938	5.090	EY 6.5-4-4591-1X

26121, 26221, 26321, 26421, 26426					
1	1610	2.149-16	2.938	6.250	EY 5-4-5161-1X
1	1610	2.149-16	2.938	6.250	EY 5-4-5161X <i>High angle yoke</i>
1	1710	2.149-16	2.938	5.500	EY 6-4-4171-1X
1	1710	2.149-16	2.938	5.500	EY 6-4-4171X
1	1760	2.149-16	2.938	5.812	EY 6.3-4-141
1	1760	2.149-16	2.938	5.812	EY 6.3-4-141-1
1	1760	2.149-16	2.938	5.812	EY 6.3-4-251-1X
1	1760	2.149-16	2.938	5.812	EY 6.3-4-251X
1	1810	2.149-16	2.938	5.812	EY 6.5-4-2401-1X
1	1810	2.149-16	2.938	5.812	EY 6.5-4-2401X

30055-P					
1	1810	2.143-41	2.938	3.500	CF 6.5-1-2941
1	1710	2.143-41	2.938	5.190	EY 6-4-7311
1	1710	2.143-41	2.938	5.190	EY 6-4-7311-1
1	1710	2.143-41	2.938	6.125	EY 6-4-7551 <i>High angle yoke</i>
1	1710	2.143-41	2.938	6.125	EY 6-4-7551-1 <i>High angle yoke</i>
1	1710	2.143-41	2.938	5.190	EY 6-4-9171-1X
1	1710	2.143-41	2.938	5.190	EY 6-4-9171X
1	1710	2.143-41	2.938	6.125	EY 6-4-9181-1X <i>High angle yoke</i>
1	1710	2.143-41	2.938	6.125	EY 6-4-9181X <i>High angle yoke</i>
1	1760	2.143-41	2.938	5.250	EY 6.3-4-1061
1	1760	2.143-41	2.938	5.250	EY 6.3-4-1061-1
1	1760	2.143-41	2.938	5.250	EY 6.3-4-1631-1X
1	1810	2.143-41	2.938	5.250	EY 6.5-4-4601-1X
1	1810	2.143-41	2.938	5.250	EY 6.5-4-4601X
1	SPL100	2.143-41	2.938	4.562	EY 100-4-1051-1
1	SPL100	2.143-41	2.938	4.562	EY 100-4-1061-1X
1	SPL140	2.143-41	2.938	5.560	EY 140-4-421-1
1	SPL140	2.143-41	2.938	5.560	EY 140-4-431-1X
1	SPL170	2.143-41	2.938	5.320	EY 170-4-351-1
1	SPL170	2.143-41	2.938	5.320	EY 170-4-361-1X
1	SPL170	2.143-41	2.938	6.680	EY 170-4-371-1 <i>High angle yoke</i>

Pos	Series	Spline Data	Hub Dia	* to End of Hub	End Fitting Part Number
30055-P (Continued)					
1	SPL170	2.143-41	2.938	6.680	EY 170-4-381-1X <i>High angle yoke</i>
1	SPL250	2.143-41	2.938	5.490	EY 250-4-131-1
1	SPL250	2.143-41	2.938	5.490	EY 250-4-141-1X
1	SPL90	2.143-41	2.938	4.562	EY 90-4-471-1
1	SPL90	2.143-41	2.938	4.562	EY 90-4-691-1X
1	1550	2.143-41	2.938	4.500	EY 4-4-5581-1
1	1610	2.143-41	2.938	5.250	EY 5-4-7271-1
1	1610	2.143-41	2.938	6.000	EY 5-4-7561
1	1610	2.143-41	2.938	6.000	EY 5-4-7561-1
1	1610	2.143-41	2.938	5.250	EY 5-4-9111-1X
1	1610	2.143-41	2.938	6.000	EY 5-4-9121-1X
1	1610	2.143-41	2.938	6.000	EY 5-4-9121X

30080-A					
1	SPL100	2.281-44	2.938	4.469	EY 100-4-1381-1X
1	SPL140	2.274-44	2.938	5.190	EY 140-4-1191-1
1	SPL140	2.274-44	2.938	5.190	EY 140-4-1201-1X
1	SPL140	2.274-44	2.938	5.190	EY 140-4-441-1
1	SPL140	2.274-44	2.938	5.190	EY 140-4-451-1X
1	SPL170	2.274-44	2.938	5.094	EY 170-4-21-1
1	SPL170	2.274-44	2.938	5.094	EY 170-4-31-1X
1	SPL250	2.274-44	2.938	5.328	EY 250-4-31-1
1	SPL250	2.274-44	2.938	5.328	EY 250-4-41-1X
1	SPL90	2.281-44	2.938	4.469	EY 90-4-281-1
1	1610	2.274-44	2.938	4.844	EY 5-4-8021-1
1	1610	2.274-44	2.938	4.844	EY 5-4-9101-1X
1	1710	2.274-44	2.938	5.031	EY 6-4-7961
1	1710	2.274-44	2.938	5.031	EY 6-4-7961-1
1	1710	2.274-44	2.938	5.031	EY 6-4-9161-1X
1	1710	2.274-44	2.938	5.031	EY 6-4-9161X
1	1760	2.274-44	2.938	5.094	EY 6.3-4-1321
1	1760	2.274-44	2.938	5.094	EY 6.3-4-1321-1
1	1760	2.274-44	2.938	5.094	EY 6.3-4-1621-1X
1	1760	2.274-44	2.938	5.094	EY 6.3-4-1621X
1	1810	2.274-44	2.938	5.090	EY 6.5-4-4081-1
1	1810	2.274-44	2.938	5.090	EY 6.5-4-4591-1X

30080-D, 30080-S					
1	SPL100	2.281-44	2.938	4.469	EY 100-4-1381-1X
1	SPL140	2.274-44	2.938	5.190	EY 140-4-1191-1
1	SPL140	2.274-44	2.938	5.190	EY 140-4-1201-1X
1	SPL140	2.143-41	2.938	5.560	EY 140-4-421-1
1	SPL140	2.143-41	2.938	5.560	EY 140-4-431-1X
1	SPL140	2.274-44	2.938	5.190	EY 140-4-441-1
1	SPL140	2.274-44	2.938	5.190	EY 140-4-451-1X
1	SPL170	2.274-44	2.938	5.094	EY 170-4-21-1
1	SPL170	2.274-44	2.938	5.094	EY 170-4-31-1X
1	SPL170	2.143-41	2.938	5.320	EY 170-4-351-1
1	SPL170	2.143-41	2.938	5.320	EY 170-4-361-1X
1	SPL170	2.143-41	2.938	6.680	EY 170-4-371-1 <i>High angle yoke</i>
1	SPL170	2.143-41	2.938	6.680	EY 170-4-381-1X <i>High angle yoke</i>
1	SPL250	2.143-41	2.938	5.490	EY 250-4-131-1
1	SPL250	2.143-41	2.938	5.490	EY 250-4-141-1X
1	SPL250	2.274-44	2.938	5.328	EY 250-4-31-1
1	SPL250	2.274-44	2.938	5.328	EY 250-4-41-1X
1	SPL90	2.281-44	2.938	4.469	EY 90-4-281-1

Continued on next page

*C/L to End of Hub for EY (End Yoke); Flange Face to End of Hub for CF (Companion Flange)

■ Hub machined for speedometer gear



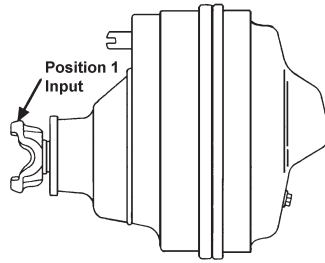

Pos	Series	Spline Data	Hub Dia	* to End of Hub	End Fitting Part Number
-----	--------	-------------	---------	-----------------	-------------------------

30080-D, 30080-S (Continued)

1	1610	2.274-44	2.938	4.844	EY 5-4-8021-1
1	1610	2.274-44	2.938	4.844	EY 5-4-9101-1X
1	1710	2.274-44	2.938	5.031	EY 6-4-7961
1	1710	2.274-44	2.938	5.031	EY 6-4-7961-1
1	1710	2.274-44	2.938	5.031	EY 6-4-9161-1X
1	1710	2.274-44	2.938	5.031	EY 6-4-9161X
1	1760	2.274-44	2.938	5.094	EY 6.3-4-1321
1	1760	2.274-44	2.938	5.094	EY 6.3-4-1321-1
1	1760	2.274-44	2.938	5.094	EY 6.3-4-1621-1X
1	1760	2.274-44	2.938	5.094	EY 6.3-4-1621X
1	1810	2.274-44	2.938	5.090	EY 6.5-4-4081-1
1	1810	2.274-44	2.938	5.090	EY 6.5-4-4591-1X

30105

1	1810	2.274-44	2.938	3.094	CF 6.5-1-2401X
1	1610	2.274-44	2.938	5.000	EY 5-4-6381-1X
1	1710	2.274-44	2.938	5.188	EY 6-4-6041-1X
1	1710	2.274-44	2.938	5.188	EY 6-4-6041X
1	1760	2.274-44	2.938	5.250	EY 6.3-4-331-1X
1	1760	2.274-44	2.938	5.250	EY 6.3-4-331X
1	1810	2.274-44	2.938	5.250	EY 6.5-4-3281-1X
1	1810	2.274-44	2.938	5.250	EY 6.5-4-3281X

30105-D, 30105-S

1	SPL100	2.281-44	2.938	4.469	EY 100-4-1381-1X
1	SPL140	2.274-44	2.938	5.190	EY 140-4-1191-1
1	SPL140	2.274-44	2.938	5.190	EY 140-4-1201-1X
1	SPL140	2.143-41	2.938	5.560	EY 140-4-421-1
1	SPL140	2.143-41	2.938	5.560	EY 140-4-431-1X
1	SPL140	2.274-44	2.938	5.190	EY 140-4-441-1
1	SPL140	2.274-44	2.938	5.190	EY 140-4-451-1X
1	SPL170	2.274-44	2.938	5.094	EY 170-4-21-1
1	SPL170	2.274-44	2.938	5.094	EY 170-4-31-1X
1	SPL170	2.143-41	2.938	5.320	EY 170-4-351-1
1	SPL170	2.143-41	2.938	5.320	EY 170-4-361-1X
1	SPL170	2.143-41	2.938	6.680	EY 170-4-371-1
					<i>High angle yoke</i>
1	SPL170	2.143-41	2.938	6.680	EY 170-4-381-1X
					<i>High angle yoke</i>
1	SPL250	2.143-41	2.938	5.490	EY 250-4-131-1
1	SPL250	2.143-41	2.938	5.490	EY 250-4-141-1X
1	SPL250	2.274-44	2.938	5.328	EY 250-4-31-1
1	SPL250	2.274-44	2.938	5.328	EY 250-4-41-1X
1	SPL90	2.281-44	2.938	4.469	EY 90-4-281-1
1	1610	2.274-44	2.938	4.844	EY 5-4-8021-1
1	1610	2.274-44	2.938	4.844	EY 5-4-9101-1X
1	1710	2.274-44	2.938	5.031	EY 6-4-7961
1	1710	2.274-44	2.938	5.031	EY 6-4-7961-1
1	1710	2.274-44	2.938	5.031	EY 6-4-9161-1X
1	1710	2.274-44	2.938	5.031	EY 6-4-9161X

Pos	Series	Spline Data	Hub Dia	* to End of Hub	End Fitting Part Number
-----	--------	-------------	---------	-----------------	-------------------------

30105-D, 30105-S (Continued)

1	1760	2.274-44	2.938	5.094	EY 6.3-4-1321
1	1760	2.274-44	2.938	5.094	EY 6.3-4-1321-1
1	1760	2.274-44	2.938	5.094	EY 6.3-4-1621-1X
1	1760	2.274-44	2.938	5.094	EY 6.3-4-1621X
1	1810	2.274-44	2.938	5.090	EY 6.5-4-4081-1
1	1810	2.274-44	2.938	5.090	EY 6.5-4-4591-1X

30127

1	1610	2.149-16	2.938	6.250	EY 5-4-5161-1X
1	1610	2.149-16	2.938	6.250	EY 5-4-5161X
					<i>High angle yoke</i>
1	1710	2.149-16	2.938	5.500	EY 6-4-4171-1X
1	1710	2.149-16	2.938	5.500	EY 6-4-4171X
1	1760	2.149-16	2.938	5.812	EY 6.3-4-251-1X
1	1760	2.149-16	2.938	5.812	EY 6.3-4-251X
1	1810	2.149-16	2.938	5.812	EY 6.5-4-2401-1X
1	1810	2.149-16	2.938	5.812	EY 6.5-4-2401X

33055-P

1	1810	2.143-41	2.938	5.250	EY 6.5-4-4601X
---	------	----------	-------	-------	----------------

35055-P

1	SPL90	2.143-41	2.938	4.562	CF 90-4-691-1X
1	SPL100	2.143-41	2.938	4.562	EY 100-4-1061-1X
1	SPL170	2.143-41	2.938	5.320	EY 170-4-361-1X
1	SPL170	2.143-41	2.938	6.680	EY 170-4-381-1X
					<i>High angle yoke</i>
1	SPL90	2.143-41	2.938	4.562	EY 90-4-471-1
1	SPL90	2.143-41	2.938	4.562	EY 90-4-691-1X
1	1610	2.143-41	2.938	5.250	EY 5-4-9111-1X
1	1610	2.143-41	2.938	6.000	EY 5-4-9121X
1	1710	2.143-41	2.938	6.125	EY 6-4-9181-1X
					<i>High angle yoke</i>
1	1710	2.143-41	2.938	6.125	EY 6-4-9181X
					<i>High angle yoke</i>

35327

1	1610	2.149-16	2.938	6.250	EY 5-4-5161-1X
1	1610	2.149-16	2.938	6.250	EY 5-4-5161X
					<i>High angle yoke</i>
1	1710	2.149-16	2.938	5.500	EY 6-4-4171-1X
1	1710	2.149-16	2.938	5.500	EY 6-4-4171X
1	1760	2.149-16	2.938	5.812	EY 6.3-4-141
1	1760	2.149-16	2.938	5.812	EY 6.3-4-141-1
1	1760	2.149-16	2.938	5.812	EY 6.3-4-251-1X
1	1760	2.149-16	2.938	5.812	EY 6.3-4-251X
1	1810	2.422-18	3.375	5.812	EY 6.5-4-1991-1
1	1810	2.149-16	2.938	5.812	EY 6.5-4-2291
1	1810	2.149-16	2.938	5.812	EY 6.5-4-2291-1
1	1810	2.149-16	2.938	5.812	EY 6.5-4-2401-1X
1	1810	2.149-16	2.938	5.812	EY 6.5-4-2401X

*C/L to End of Hub for EY (End Yoke); Flange Face to End of Hub for CF (Companion Flange)

■ Hub machined for speedometer gear



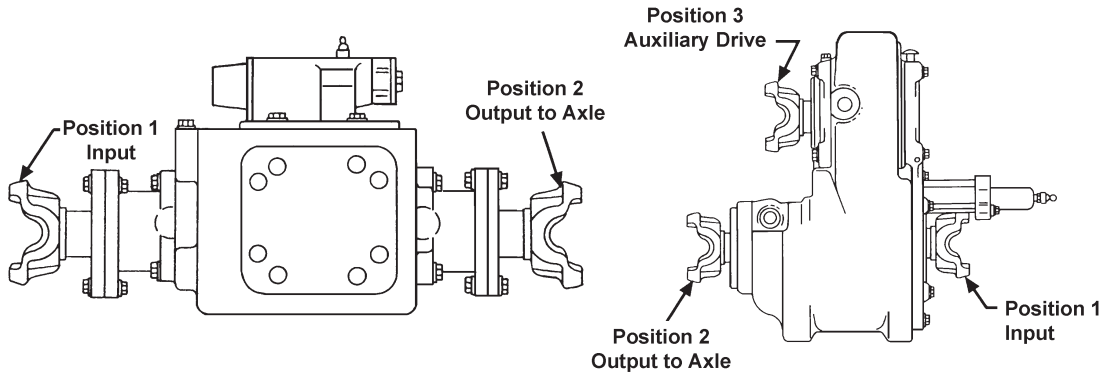

Pos	Series	Spline Data	Hub Dia	* to End of Hub	End Fitting Part Number
900, 901					
1	1480/1410	1.750-10	2.500	3.000	CF 4-1-3891
2	1480/1410	1.750-10	2.500	3.000	CF 4-1-3891 <i>Can be used w/brake</i>
3	1350/1410	1.500-10	2.000	2.906	CF 3-1-3431 .310 deep counterbore at hub end
910 (**)					
1	1710	2.500-10	3.750	5.625	EY 6-4-6921X ** Two Spline Options ■
2	1710	2.500-10	3.750	5.625	EY 6-4-6921X ** Two Spline Options ■
911 (**)					
1	1710	2.500-10	3.750	3.625	CF 6-1-5651X ** Two Spline Options
1	1710	2.500-10	3.750	5.625	EY 6-4-6921X ** Two Spline Options ■
2	1710	2.500-10	3.750	3.625	CF 6-1-5651X ** Two Spline Options
2	1710	2.500-10	3.750	5.625	EY 6-4-6921X ** Two Spline Options ■
912					
1	SPL170	2.750-10	3.750	5.850	EY 170-4-521-1X
1	SPL250	2.750-10	3.750	6.297	EY 250-4-241-1X
1	1710	2.750-10	3.750	5.750	EY 6-4-6931-1X
1	1710	2.750-10	3.750	5.750	EY 6-4-6931X
1	1810	2.750-10	3.750	6.062	EY 6.5-4-3561-1X
1	1810	2.750-10	3.750	6.062	EY 6.5-4-3561X
2	SPL170	2.750-10	3.750	5.850	EY 170-4-521-1X
2	SPL250	2.750-10	3.750	6.297	EY 250-4-241-1X
2	1710	2.750-10	3.750	5.750	EY 6-4-6931-1X
2	1710	2.750-10	3.750	5.750	EY 6-4-6931X
2	1810	2.750-10	3.750	6.062	EY 6.5-4-3561-1X
2	1810	2.750-10	3.750	6.062	EY 6.5-4-3561X
930, 931					
1	1350/1410	1.375-10	1.750	2.250	CF 3-1-3881
2	1350/1410	1.375-10	1.750	2.250	CF 3-1-3881 <i>Can be used w/brake</i>
941					
1	1350/1410	1.500-10	2.125	2.438	CF 3-1-2431
1	1550	1.500-10	2.125	2.625	CF 4-1-2701
2	1550	1.500-10	2.125	2.625	CF 4-1-2701
4551					
2	1350/1410	1.375-10	1.750	2.250	CF 3-1-3881 <i>Can be used w/brake</i>

Pos	Series	Spline Data	Hub Dia	* to End of Hub	End Fitting Part Number
4552, 4553, 4561					
1	1350/1410	1.375-10	1.750	2.250	CF 3-1-3881
2	1350/1410	1.375-10	1.750	2.250	CF 3-1-3881 <i>Can be used w/brake</i>
4600, 4605, 4608					
1	1480/1410	1.750-10	2.500	3.000	CF 4-1-3891
2	1480/1410	1.750-10	2.500	3.000	CF 4-1-3891 <i>Can be used w/brake</i>
3	1350/1410	1.500-10	2.000	2.906	CF 3-1-3431 .310 deep counterbore at hub end
4700, 4701					
1	1480/1550	1.964-10	2.500	3.000	CF 4-1-3761
1	1610	1.964-10	2.500	3.000	CF 5-1-4291
2	1610	1.962-10	2.500	3.250	CF 5-1-4301
4704					
1	1610	1.964-10	2.500	3.000	CF 5-1-4291
2	1610	1.962-10	2.500	3.250	CF 5-1-4301
4714					
1	1480/1550	1.964-10	2.500	3.000	CF 4-1-3761
1	1610	1.964-10	2.500	3.000	CF 5-1-4291
2	1610	1.962-10	2.500	3.250	CF 5-1-4301
4724					
1	1610	1.964-10	2.500	3.000	CF 5-1-4291
2	1610	1.962-10	2.500	3.250	CF 5-1-4301
4900					
1	1710	2.500-10	3.750	3.625	CF 6-1-5651X
1	1710	2.500-10	3.750	5.625	EY 6-4-6921X ■
2	1710	2.500-10	3.750	3.625	CF 6-1-5651X
2	1710	2.500-10	3.750	5.625	EY 6-4-6921X ■

*C/L to End of Hub for EY (End Yoke); Flange Face to End of Hub for CF (Companion Flange)

■ Hub machined for speedometer gear



Important: See Safety Information in General Information Section (J300P-GI)

Tandem Axles Axle Alliance Corp., Clark & Navistar / International

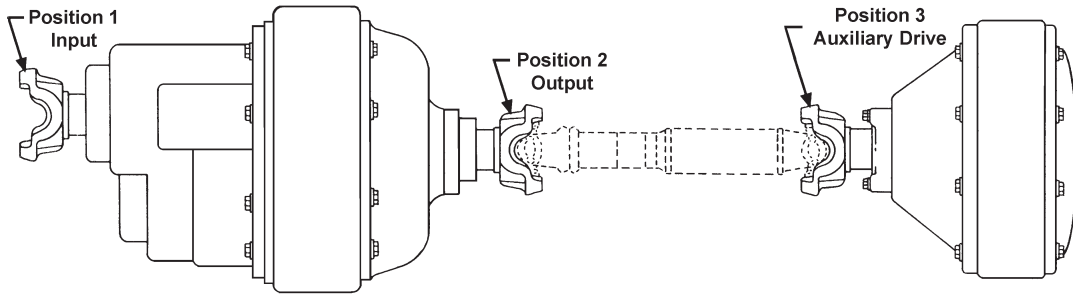

Pos	Series	Spline Data	Hub Dia	* to End of Hub	End Fitting Part Number
-----	--------	-------------	---------	-----------------	-------------------------

AXLE ALLIANCE CORP.

4					
1	SPL350	2.390-46	3.252	5.551	EY 350-4-71-1X
3	SPL100	2.143-41	3.000	4.310	EY 100-4-02875-1X
3	SPL100	2.143-41	3.000	4.310	EY 5002874
3	SPL100	2.143-41	3.000	4.310	EY 5002875
3	1610	2.143-41	3.000	4.680	EY 5002873
3	1710	2.143-41	3.000	5.380	EY 5002876
					<i>High angle yoke</i>
3	1710	2.143-41	3.000	5.380	EY 5002877
					<i>High angle yoke</i>
3	1710	2.143-41	3.000	5.030	EY 5002878
3	1710	2.143-41	3.000	5.030	EY 5002879
3	1710	2.143-41	3.000	5.380	EY 6-4-02877-1X
					<i>High angle yoke</i>

CLARK

BD-45-60, BD-50-60					
1	1710	2.005-15	2.875	5.375	EY 6-4-3001
2	1710	1.775-16	2.375	4.750	EY 6-4-4271
3	1710	2.005-15	2.875	5.375	EY 6-4-3001
BD-50-70, BD-80-120, BD-57000, BD-65000, BD-65200, BD-70000, BD-71000, BD-90000, BD-91000, BD-100000, BD-101000					
1	1710	2.631-25	3.625	5.250	EY 6-4-3021
1	1810	2.631-25	3.625	5.781	EY 6.5-4-2181
2	1710	2.005-15	2.875	5.375	EY 6-4-3001
2	1810	2.005-15	2.875	5.250	EY 6.5-4-2911
3	1710	2.631-25	3.625	5.250	EY 6-4-3021
3	1810	2.631-25	3.625	5.781	EY 6.5-4-2181
BE-45-60					
1	1710	2.005-15	2.875	5.375	EY 6-4-3001
2	1710	1.775-16	2.375	4.750	EY 6-4-4271
3	1710	2.005-15	2.875	5.375	EY 6-4-3001

Pos	Series	Spline Data	Hub Dia	* to End of Hub	End Fitting Part Number
-----	--------	-------------	---------	-----------------	-------------------------

NAVISTAR / INTERNATIONAL

RA-341					
1	1610	1.939-30	3.000	4.750	EY 5-4-4391
1	1710	1.939-30	3.000	4.562	EY 6-4-4371
1	1810	1.939-30	3.000	5.375	EY 6.5-4-2051
2	1480	1.964-10	2.500	4.688	EY 3-4-4211
2	1610	1.962-10	2.500	5.219	EY 5-4-4551
RA-351					
1	1550	2.364-36	3.000	5.078	EY 4-4-7111-1X
1	1610	2.364-36	3.000	5.156	EY 5-4-5631
1	1610	2.364-36	3.000	5.156	EY 5-4-7201X
1	1610	2.364-36	3.000	5.156	EY 5-4-7211X
1	1610	2.364-36	3.000	5.156	EY 5-4-8631-1X
1	1610	2.364-36	3.000	5.156	EY 5-4-8651-1X
1	1710	2.364-36	3.000	5.438	EY 6-4-5711
1	1710	2.364-36	3.000	5.438	EY 6-4-7191X
1	1710	2.364-36	3.000	5.438	EY 6-4-7211X
1	1710	2.364-36	3.000	5.438	EY 6-4-8701-1X
1	1710	2.364-36	3.000	5.438	EY 6-4-8721-1X
1	1760	2.364-36	3.000	5.438	EY 6.3-4-1561-1X
1	1760	2.364-36	3.000	5.438	EY 6.3-4-851X
1	1810	1.939-30	3.000	5.375	EY 6.5-4-2051
1	1810	2.364-36	3.000	5.438	EY 6.5-4-3161
1	1810	2.364-36	3.000	5.438	EY 6.5-4-3651X
1	1810	2.364-36	3.000	5.438	EY 6.5-4-4421-1X
1	1810	2.364-36	3.000	5.438	EY 6.5-4-4441-1X
2	1480	1.964-10	2.500	4.688	EY 3-4-4211
2	1610	1.962-10	2.500	5.219	EY 5-4-4551
2	1610	1.989-30	3.000	6.000	EY 5-4-5721
2	1610	2.364-36	3.000	6.000	EY 5-4-7231X
2	1610	1.989-30	3.000	6.000	EY 5-4-7251X
2	1710	2.364-36	3.000	5.438	EY 6-4-5711
2	1710	2.364-36	3.000	6.500	EY 6-4-5801
					<i>High angle yoke</i>
2	1710	2.364-36	3.000	5.438	EY 6-4-7191X
2	1710	1.989-30	3.000	6.280	EY 6-4-7231X
					<i>High angle yoke</i>
2	1710	2.364-36	3.000	6.500	EY 6-4-7241X
					<i>High angle yoke</i>
2	1710	2.364-36	3.000	5.438	EY 6-4-8701-1X
2	1810	2.364-36	3.000	5.438	EY 6.5-4-3161
2	1810	2.364-36	3.000	5.438	EY 6.5-4-3651X
2	1810	2.364-36	3.000	5.438	EY 6.5-4-4421-1X
3	1610	1.962-10	3.000	5.375	EY 5-4-4541
3	1610	2.114-32	3.000	6.000	EY 5-4-5731
3	1610	2.114-32	3.000	5.375	EY 5-4-5751

Continued on next page

*C/L to End of Hub for EY (End Yoke); Flange Face to End of Hub for CF (Companion Flange)

■ Hub machined for speedometer gear



Important: See Safety Information in General Information Section (J300P-GI)

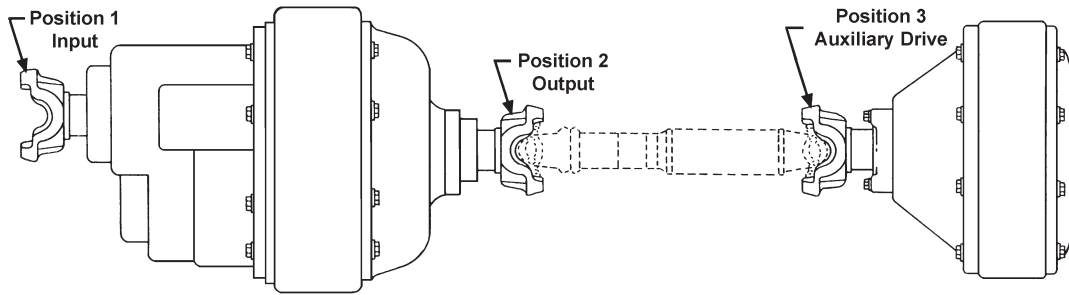

Pos	Series	Spline Data	Hub Dia	* to End of Hub	End Fitting Part Number
RA-351 (Continued)					
3	1610	2.114-32	3.000	6.000	EY 5-4-7181X
3	1610	2.114-32	3.000	5.375	EY 5-4-7221X
3	1610	2.114-32	3.000	5.375	EY 5-4-8611-1X
3	1710	1.964-10	3.000	4.562	EY 6-4-3291
3	1710	2.114-32	3.000	6.250	EY 6-4-5791
					<i>High angle yoke</i>
3	1710	2.114-32	3.000	4.562	EY 6-4-5811
3	1710	2.114-32	3.000	6.250	EY 6-4-7171X
					<i>High angle yoke</i>
3	1710	2.114-32	3.000	4.562	EY 6-4-7221X
3	1710	2.114-32	3.000	4.562	EY 6-4-8681-1X

Pos	Series	Spline Data	Hub Dia	* to End of Hub	End Fitting Part Number
RA-355 (Continued)					
2	1810	2.364-36	3.000	5.438	EY 6.5-4-3161
2	1810	2.364-36	3.000	5.438	EY 6.5-4-3651X
2	1810	2.364-36	3.000	5.438	EY 6.5-4-4421-1X
3	1710	1.964-10	3.000	4.562	EY 6-4-3291
3	1710	2.114-32	3.000	6.250	EY 6-4-5791
					<i>High angle yoke</i>
3	1710	2.114-32	3.000	4.562	EY 6-4-5811
3	1710	2.114-32	3.000	6.250	EY 6-4-7171X
					<i>High angle yoke</i>
3	1710	2.114-32	3.000	4.562	EY 6-4-7221X
3	1710	2.114-32	3.000	4.562	EY 6-4-8681-1X

Pos	Series	Spline Data	Hub Dia	* to End of Hub	End Fitting Part Number
RA-355					
1	1550	2.364-36	3.000	5.078	EY 4-4-7111-1X
1	1610	1.939-30	3.000	4.750	EY 5-4-4391
1	1610	2.364-36	3.000	5.156	EY 5-4-5631
1	1610	2.364-36	3.000	5.156	EY 5-4-7201X
1	1610	2.364-36	3.000	5.156	EY 5-4-7211X
1	1610	2.364-36	3.000	5.156	EY 5-4-8631-1X
1	1610	2.364-36	3.000	5.156	EY 5-4-8651-1X
1	1710	1.939-30	3.000	4.562	EY 6-4-4371
1	1710	2.364-36	3.000	5.438	EY 6-4-5711
1	1710	2.364-36	3.000	5.438	EY 6-4-7191X
1	1710	2.364-36	3.000	5.438	EY 6-4-7211X
1	1710	2.364-36	3.000	5.438	EY 6-4-8701-1X
1	1710	2.364-36	3.000	5.438	EY 6-4-8721-1X
1	1760	2.364-36	3.000	5.438	EY 6.3-4-1551-1
1	1760	2.364-36	3.000	5.438	EY 6.3-4-1561-1X
1	1760	1.939-30	3.000	5.250	EY 6.3-4-431
1	1760	2.364-36	3.000	5.438	EY 6.3-4-851X
1	1810	1.939-30	3.000	5.375	EY 6.5-4-2051
1	1810	2.364-36	3.000	5.438	EY 6.5-4-3161
1	1810	2.364-36	3.000	5.438	EY 6.5-4-3651X
1	1810	2.364-36	3.000	5.438	EY 6.5-4-4421-1X
1	1810	2.364-36	3.000	5.438	EY 6.5-4-4441-1X
2	1480	1.964-10	2.500	4.688	EY 3-4-4211
2	1610	1.962-10	2.500	5.219	EY 5-4-4551
2	1610	1.989-30	3.000	6.000	EY 5-4-5721
2	1610	2.364-36	3.000	6.000	EY 5-4-7231X
2	1610	1.989-30	3.000	6.000	EY 5-4-7251X
2	1710	2.364-36	3.000	5.438	EY 6-4-5711
2	1710	2.364-36	3.000	6.500	EY 6-4-5801
					<i>High angle yoke</i>
2	1710	2.364-36	3.000	5.438	EY 6-4-7191X
2	1710	1.989-30	3.000	6.280	EY 6-4-7231X
					<i>High angle yoke</i>
2	1710	2.364-36	3.000	6.500	EY 6-4-7241X
					<i>High angle yoke</i>
2	1710	2.364-36	3.000	5.438	EY 6-4-8701-1X

Pos	Series	Spline Data	Hub Dia	* to End of Hub	End Fitting Part Number
RA-386, RA-387, RA-471					
1	1550	2.364-36	3.000	5.078	EY 4-4-7111-1X
1	1610	1.939-30	3.000	4.750	EY 5-4-4391
1	1610	2.364-36	3.000	5.156	EY 5-4-5631
1	1610	2.364-36	3.000	5.156	EY 5-4-7201X
1	1610	2.364-36	3.000	5.156	EY 5-4-7211X
1	1610	2.364-36	3.000	5.156	EY 5-4-8631-1X
1	1610	2.364-36	3.000	5.156	EY 5-4-8651-1X
1	1710	1.939-30	3.000	4.562	EY 6-4-4371
1	1710	2.364-36	3.000	5.438	EY 6-4-5711
1	1710	2.364-36	3.000	5.438	EY 6-4-7191X
1	1710	2.364-36	3.000	5.438	EY 6-4-7211X
1	1710	2.364-36	3.000	5.438	EY 6-4-8701-1X
1	1710	2.364-36	3.000	5.438	EY 6-4-8721-1X
1	1760	2.364-36	3.000	5.438	EY 6.3-4-1551-1
1	1760	2.364-36	3.000	5.438	EY 6.3-4-1561-1X
1	1760	1.939-30	3.000	5.250	EY 6.3-4-431
1	1810	1.939-30	3.000	5.375	EY 6.5-4-2051
1	1810	2.364-36	3.000	5.438	EY 6.5-4-3161
1	1810	2.364-36	3.000	5.438	EY 6.5-4-3651X
1	1810	2.364-36	3.000	5.438	EY 6.5-4-4421-1X
1	1810	2.364-36	3.000	5.438	EY 6.5-4-4441-1X
2	1480	1.964-10	2.500	4.688	EY 3-4-4211
2	1610	1.962-10	2.500	5.219	EY 5-4-4551
2	1610	1.989-30	3.000	6.000	EY 5-4-5721
2	1610	2.364-36	3.000	6.000	EY 5-4-7231X
2	1610	1.989-30	3.000	6.000	EY 5-4-7251X
2	1710	2.364-36	3.000	5.438	EY 6-4-5711
2	1710	2.364-36	3.000	6.500	EY 6-4-5801
					<i>High angle yoke</i>
2	1710	2.364-36	3.000	5.438	EY 6-4-7191X
2	1710	1.989-30	3.000	6.280	EY 6-4-7231X
					<i>High angle yoke</i>
2	1710	2.364-36	3.000	6.500	EY 6-4-7241X
					<i>High angle yoke</i>
2	1710	2.364-36	3.000	5.438	EY 6-4-8701-1X
2	1810	2.364-36	3.000	5.438	EY 6.5-4-3161

*C/L to End of Hub for EY (End Yoke); Flange Face to End of Hub for CF (Companion Flange)

■ Hub machined for speedometer gear



Pos	Series	Spline Data	Hub Dia	* to End of Hub	End Fitting Part Number
RA-386, RA-387, RA-471 (Continued)					
2	1810	2.364-36	3.000	5.438	EY 6.5-4-3651X
2	1810	2.364-36	3.000	5.438	EY 6.5-4-4421-1X
3	1610	1.962-10	3.000	5.375	EY 5-4-4541
3	1610	2.114-32	3.000	6.000	EY 5-4-5731
3	1610	2.114-32	3.000	5.375	EY 5-4-5751
3	1610	2.114-32	3.000	6.000	EY 5-4-7181X
3	1610	2.114-32	3.000	5.375	EY 5-4-7221X
3	1610	2.114-32	3.000	5.375	EY 5-4-8611-1X
3	1710	1.964-10	3.000	4.562	EY 6-4-3291
3	1710	2.114-32	3.000	6.250	EY 6-4-5791 <i>High angle yoke</i>
3	1710	2.114-32	3.000	4.562	EY 6-4-5811
3	1710	2.114-32	3.000	6.250	EY 6-4-7171X <i>High angle yoke</i>
3	1710	2.114-32	3.000	4.562	EY 6-4-7221X
3	1710	2.114-32	3.000	4.562	EY 6-4-8681-1X

Pos	Series	Spline Data	Hub Dia	* to End of Hub	End Fitting Part Number
RA-472, RA-474					
1	1550	2.364-36	3.000	5.078	EY 4-4-7111-1X
1	1610	1.939-30	3.000	4.750	EY 5-4-4391
1	1610	2.364-36	3.000	5.156	EY 5-4-5631
1	1610	2.364-36	3.000	5.156	EY 5-4-7201X
1	1610	2.364-36	3.000	5.156	EY 5-4-7211X
1	1610	2.364-36	3.000	5.156	EY 5-4-8631-1X
1	1610	2.364-36	3.000	5.156	EY 5-4-8651-1X
1	1710	1.939-30	3.000	4.562	EY 6-4-4371
1	1710	2.364-36	3.000	5.438	EY 6-4-5711
1	1710	2.364-36	3.000	5.438	EY 6-4-7191X
1	1710	2.364-36	3.000	5.438	EY 6-4-7211X
1	1710	2.364-36	3.000	5.438	EY 6-4-8701-1X
1	1710	2.364-36	3.000	5.438	EY 6-4-8721-1X
1	1760	2.364-36	3.000	5.438	EY 6.3-4-1551-1
1	1760	2.364-36	3.000	5.438	EY 6.3-4-1561-1X
1	1760	2.364-36	3.000	5.438	EY 6.3-4-851X
1	1810	1.939-30	3.000	5.375	EY 6.5-4-2051
1	1810	2.364-36	3.000	5.438	EY 6.5-4-3161
1	1810	2.364-36	3.000	5.438	EY 6.5-4-3641X
1	1810	2.364-36	3.000	5.438	EY 6.5-4-3651X
1	1810	2.364-36	3.000	5.438	EY 6.5-4-4421-1X
1	1810	2.364-36	3.000	5.438	EY 6.5-4-4441-1X
2	1480	1.964-10	2.500	4.688	EY 3-4-4211
2	1610	1.962-10	2.500	5.219	EY 5-4-4551
2	1610	1.989-30	3.000	6.000	EY 5-4-5721
2	1610	2.364-36	3.000	6.000	EY 5-4-7231X
2	1610	1.989-30	3.000	6.000	EY 5-4-7251X
2	1610	1.989-30	3.000	6.000	EY 5-4-8671-1X <i>High angle yoke</i>
2	1710	2.364-36	3.000	5.438	EY 6-4-5711
2	1710	2.364-36	3.000	6.500	EY 6-4-5801 <i>High angle yoke</i>
2	1710	2.364-36	3.000	5.438	EY 6-4-7191X
2	1710	1.989-30	3.000	6.280	EY 6-4-7231X <i>High angle yoke</i>
2	1710	2.364-36	3.000	6.500	EY 6-4-7241X <i>High angle yoke</i>
2	1710	2.364-36	3.000	5.438	EY 6-4-8701-1X
2	1810	2.364-36	3.000	5.438	EY 6.5-4-3161
2	1810	2.364-36	3.000	5.438	EY 6.5-4-3651X
2	1810	2.364-36	3.000	5.438	EY 6.5-4-4421-1X
3	1610	1.962-10	3.000	5.375	EY 5-4-4541

Pos	Series	Spline Data	Hub Dia	* to End of Hub	End Fitting Part Number
RA-472, RA-474 (Continued)					
3	1610	2.114-32	3.000	6.000	EY 5-4-5731
3	1610	2.114-32	3.000	5.375	EY 5-4-5751
3	1610	2.114-32	3.000	6.000	EY 5-4-7181X
3	1610	2.114-32	3.000	5.375	EY 5-4-7221X
3	1610	2.114-32	3.000	5.375	EY 5-4-8611-1X
3	1710	1.964-10	3.000	4.562	EY 6-4-3291
3	1710	2.114-32	3.000	6.250	EY 6-4-5791 <i>High angle yoke</i>
3	1710	2.114-32	3.000	4.562	EY 6-4-5811
3	1710	2.114-32	3.000	6.250	EY 6-4-7171X <i>High angle yoke</i>
3	1710	2.114-32	3.000	4.562	EY 6-4-7221X
3	1710	2.114-32	3.000	4.562	EY 6-4-8681-1X
RA-475, RA-476					
1	1760	2.364-36	3.000	5.438	EY 6.3-4-1551-1
1	1810	2.364-36	3.000	5.438	EY 6.5-4-3641X

Pos	Series	Spline Data	Hub Dia	* to End of Hub	End Fitting Part Number
014ADB, 014ADC, 014ADD					
1	1710	2.114-32	3.000	5.000	EY 6.3-4-1511-1

Pos	Series	Spline Data	Hub Dia	* to End of Hub	End Fitting Part Number
014GDA, 014GDB, 014GDC					
1	1550	2.114-32	3.000	4.312	EY 4-4-7001-1X
1	1610	2.114-32	3.000	5.375	EY 5-4-5751
1	1610	2.114-32	3.000	5.375	EY 5-4-7221X
1	1610	2.114-32	3.000	5.375	EY 5-4-8611-1X
1	1710	2.114-32	3.000	5.000	EY 6.3-4-1511-1
1	1710	2.114-32	3.000	4.562	EY 6-4-5811
1	1710	2.114-32	3.000	6.250	EY 6-4-7171X <i>High angle yoke</i>
1	1710	2.114-32	3.000	4.562	EY 6-4-7221X
1	1710	2.114-32	3.000	4.562	EY 6-4-8681-1X
1	1760	2.114-32	3.000	5.000	EY 6.3-4-1521-1X
1	1810	2.114-32	3.000	5.000	EY 6.5-4-4451-1
1	1810	2.114-32	3.000	5.000	EY 6.5-4-4461-1X
3	1550	2.114-32	3.000	4.312	EY 4-4-7001-1X
3	1610	2.114-32	3.000	5.375	EY 5-4-5751
3	1610	2.114-32	3.000	5.375	EY 5-4-7221X
3	1610	2.114-32	3.000	5.375	EY 5-4-8611-1X
3	1710	2.114-32	3.000	6.250	EY 6-4-7171X <i>High angle yoke</i>
3	1710	2.114-32	3.000	4.562	EY 6-4-7221X
3	1710	2.114-32	3.000	4.562	EY 6-4-8681-1X
3	1760	2.114-32	3.000	5.000	EY 6.3-4-1521-1X

*C/L to End of Hub for EY (End Yoke); Flange Face to End of Hub for CF (Companion Flange)

■ Hub machined for speedometer gear



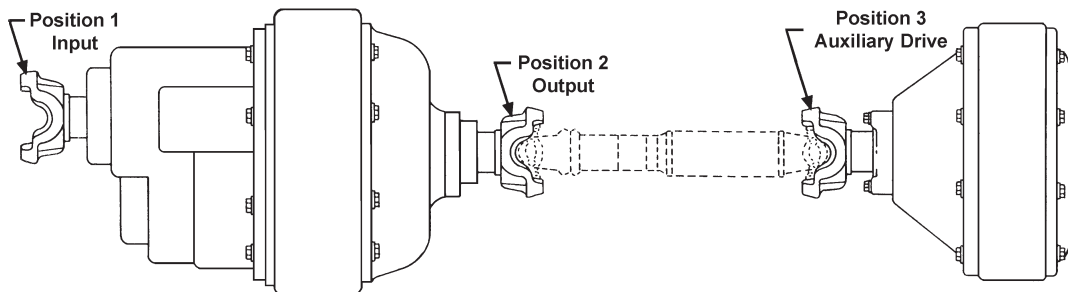

Pos	Series	Spline Data	Hub Dia	* to End of Hub	End Fitting Part Number
-----	--------	-------------	---------	-----------------	-------------------------

CRD-92

1	SPL170	2.374-46	3.500	5.880	EY 170-4-1211-1
1	SPL170	2.374-46	3.500	5.880	EY 170-4-1221-1X
1	SPL170	2.374-46	3.500	6.688	EY 170-4-1281-1 <i>High angle yoke</i>
1	SPL170	2.374-46	3.500	6.688	EY 170-4-1291-1X <i>High angle yoke</i>
1	SPL250	2.374-46	3.500	6.140	EY 250-4-641-1
1	SPL250	2.374-46	3.500	6.140	EY 250-4-651-1X
1	SPL350	2.374-46	3.500	6.220	EY 350-4-111-1X
1	1710	2.374-46	3.500	5.156	EY 6-4-5841
1	1710	2.374-46	3.500	5.156	EY 6-4-5841-1
1	1710	2.024-39	2.750	5.000	EY 6-4-5851-1
1	1710	2.374-46	3.500	5.156	EY 6-4-8341-1X
1	1710	2.374-46	3.500	5.156	EY 6-4-8341X
1	1710	2.374-46	3.500	5.840	EY 6-4-8961-1X
1	1760	2.374-46	3.500	5.375	EY 6.3-4-1391-1X
1	1760	2.374-46	3.500	5.375	EY 6.3-4-1391X
1	1760	2.374-46	3.500	5.375	EY 6.3-4-391
1	1760	2.374-46	3.500	5.375	EY 6.3-4-391-1
1	1810	2.374-46	3.500	5.406	EY 6.5-4-3251
1	1810	2.374-46	3.500	5.406	EY 6.5-4-3251-1
1	1810	2.374-46	3.500	5.406	EY 6.5-4-4271-1X
1	1810	2.374-46	3.500	5.406	EY 6.5-4-4271X
2	SPL170	2.024-39	2.750	5.370	EY 170-4-1251-1 <i>High angle yoke</i>
2	1610	2.024-39	2.750	4.500	EY 5-4-5881 <i>All suspensions except reyco and dayton</i>
2	1710	2.024-39	2.750	5.000	EY 6-4-5851 <i>All suspensions except reyco and dayton</i>
2	1710	2.024-39	2.750	5.000	EY 6-4-5851-1 <i>All suspensions except reyco and dayton</i>
2	1710	2.024-39	2.750	5.875	EY 6-4-6571 <i>Reyco and dayton suspensions only; High angle yoke</i>
2	1710	2.024-39	2.750	5.875	EY 6-4-6571-1 <i>Reyco and dayton suspensions only; High angle yoke</i>
2	1760	2.032-10	2.750	5.000	EY 6.3-4-421 <i>All suspensions except reyco and dayton</i>
2	1810	2.024-39	2.750	5.188	EY 6.5-4-3261 <i>All suspensions except reyco and dayton</i>
2	1810	2.024-39	2.750	5.188	EY 6.5-4-3261-1 <i>All suspensions except reyco and dayton</i>
3	SPL170	2.024-39	2.750	5.370	EY 170-4-1251-1 <i>High angle yoke</i>
3	SPL170	2.024-39	2.750	5.370	EY 170-4-1261-1X <i>High angle yoke</i>
3	1610	2.024-39	2.750	4.500	EY 5-4-5881 <i>All suspensions except reyco and dayton</i>
3	1710	2.024-39	2.750	5.000	EY 6-4-5851 <i>All suspensions except reyco and dayton</i>
3	1710	2.024-39	2.750	5.000	EY 6-4-5851-1 <i>All suspensions except reyco and dayton</i>

Pos	Series	Spline Data	Hub Dia	* to End of Hub	End Fitting Part Number
-----	--------	-------------	---------	-----------------	-------------------------

CRD-92 (Continued)

3	1710	2.024-39	2.750	5.875	EY 6-4-6571 <i>All suspensions except reyco and dayton; High angle yoke</i>
3	1710	2.024-39	2.750	5.875	EY 6-4-6571-1 <i>All suspensions except reyco and dayton; High angle yoke</i>
3	1710	2.024-39	2.750	5.000	EY 6-4-8331-1X <i>All suspensions except reyco and dayton</i>
3	1710	2.024-39	2.750	5.000	EY 6-4-8331X <i>All suspensions except reyco and dayton</i>
3	1710	2.024-39	2.750	5.875	EY 6-4-8361-1X <i>Reyco and dayton suspensions only; High angle yoke</i>
3	1710	2.024-39	2.750	5.875	EY 6-4-8361X <i>Reyco and dayton suspensions only; High angle yoke</i>
3	1760	2.032-10	2.750	5.000	EY 6.3-4-1261X <i>All suspensions except reyco and dayton</i>
3	1760	2.032-10	2.750	5.000	EY 6.3-4-421 <i>All suspensions except reyco and dayton</i>
3	1810	2.024-39	2.750	5.188	EY 6.5-4-3261 <i>All suspensions except reyco and dayton</i>
3	1810	2.024-39	2.750	5.188	EY 6.5-4-3261-1 <i>All suspensions except reyco and dayton</i>
3	1810	2.024-39	2.750	5.188	EY 6.5-4-4281-1X <i>All suspensions except reyco and dayton</i>
3	1810	2.024-39	2.750	5.188	EY 6.5-4-4281X <i>All suspensions except reyco and dayton</i>

CRD-93

1	SPL170	2.374-46	3.500	5.880	EY 170-4-1211-1
1	SPL170	2.374-46	3.500	5.880	EY 170-4-1221-1X
1	SPL170	2.024-39	2.750	5.370	EY 170-4-1251-1 <i>High angle yoke</i>
1	SPL170	2.374-46	3.500	6.688	EY 170-4-1281-1 <i>High angle yoke</i>
1	SPL170	2.374-46	3.500	6.688	EY 170-4-1291-1X <i>High angle yoke</i>
1	SPL250	2.374-46	3.500	6.140	EY 250-4-641-1
1	SPL250	2.374-46	3.500	6.140	EY 250-4-651-1X
1	SPL350	2.374-46	3.500	6.220	EY 350-4-111-1X
1	1710	2.374-46	3.500	5.156	EY 6-4-5841
1	1710	2.374-46	3.500	5.156	EY 6-4-5841-1
1	1710	2.024-39	2.750	5.000	EY 6-4-5851-1
1	1710	2.374-46	3.500	5.156	EY 6-4-8341-1X
1	1710	2.374-46	3.500	5.156	EY 6-4-8341X
1	1710	2.374-46	3.500	5.840	EY 6-4-8951-1
1	1710	2.374-46	3.500	5.840	EY 6-4-8961-1X
1	1760	2.374-46	3.500	5.375	EY 6.3-4-1391-1X
1	1760	2.374-46	3.500	5.375	EY 6.3-4-1391X
1	1760	2.374-46	3.500	5.375	EY 6.3-4-391
1	1760	2.374-46	3.500	5.375	EY 6.3-4-391-1
1	1810	2.374-46	3.500	5.406	EY 6.5-4-3251
1	1810	2.374-46	3.500	5.406	EY 6.5-4-3251-1
1	1810	2.374-46	3.500	5.406	EY 6.5-4-4271-1X

*C/L to End of Hub for EY (End Yoke); Flange Face to End of Hub for CF (Companion Flange)

■ Hub machined for speedometer gear



Pos	Series	Spline Data	Hub Dia	* to End of Hub	End Fitting Part Number
CRD-93 (Continued)					
1	1810	2.374-46	3.500	5.406	EY 6.5-4-4271X
2	SPL170	2.024-39	2.750	5.370	EY 170-4-1251-1 <i>High angle yoke</i>
2	1610	2.024-39	2.750	4.500	EY 5-4-5881 <i>All suspensions except reyco and dayton</i>
2	1710	2.024-39	2.750	5.000	EY 6-4-5851 <i>All suspensions except reyco and dayton</i>
2	1710	2.024-39	2.750	5.000	EY 6-4-5851-1 <i>All suspensions except reyco and dayton</i>
2	1710	2.024-39	2.750	5.875	EY 6-4-6571 <i>Reyco and dayton suspensions only; High angle yoke</i>
2	1710	2.024-39	2.750	5.875	EY 6-4-6571-1 <i>Reyco and dayton suspensions only; High angle yoke</i>
2	1760	2.032-10	2.750	5.000	EY 6.3-4-421 <i>All suspensions except reyco and dayton</i>
2	1810	2.024-39	2.750	5.188	EY 6.5-4-3261 <i>All suspensions except reyco and dayton</i>
2	1810	2.024-39	2.750	5.188	EY 6.5-4-3261-1 <i>All suspensions except reyco and dayton</i>
3	SPL170	2.024-39	2.750	5.370	EY 170-4-1251-1 <i>High angle yoke</i>
3	SPL170	2.024-39	2.750	5.370	EY 170-4-1261-1X <i>High angle yoke</i>
3	1610	2.024-39	2.750	4.500	EY 5-4-5881 <i>All suspensions except reyco and dayton</i>
3	1710	2.024-39	2.750	5.000	EY 6-4-5851 <i>All suspensions except reyco and dayton</i>
3	1710	2.024-39	2.750	5.000	EY 6-4-5851-1 <i>All suspensions except reyco and dayton</i>
3	1710	2.024-39	2.750	5.875	EY 6-4-6571 <i>All suspensions except reyco and dayton; High angle yoke</i>
3	1710	2.024-39	2.750	5.875	EY 6-4-6571-1 <i>All suspensions except reyco and dayton; High angle yoke</i>
3	1710	2.024-39	2.750	5.000	EY 6-4-8331-1X <i>All suspensions except reyco and dayton</i>
3	1710	2.024-39	2.750	5.000	EY 6-4-8331X <i>All suspensions except reyco and dayton</i>
3	1710	2.024-39	2.750	5.875	EY 6-4-8361-1X <i>Reyco and dayton suspensions only; High angle yoke</i>
3	1710	2.024-39	2.750	5.875	EY 6-4-8361X <i>Reyco and dayton suspensions only; High angle yoke</i>
3	1760	2.032-10	2.750	5.000	EY 6.3-4-421 <i>All suspensions except reyco and dayton</i>
3	1810	2.024-39	2.750	5.188	EY 6.5-4-3261 <i>All suspensions except reyco and dayton</i>
3	1810	2.024-39	2.750	5.188	EY 6.5-4-3261-1 <i>All suspensions except reyco and dayton</i>
3	1810	2.024-39	2.750	5.188	EY 6.5-4-4281-1X <i>All suspensions except reyco and dayton</i>
3	1810	2.024-39	2.750	5.188	EY 6.5-4-4281X <i>All suspensions except reyco and dayton</i>

Pos	Series	Spline Data	Hub Dia	* to End of Hub	End Fitting Part Number
CRD-95					
1	SPL170	2.500-10	3.500	5.188	EY 170-4-1341-1
1	SPL170	2.500-10	3.500	5.188	EY 170-4-1351-1X
1	SPL250	2.500-10	3.500	5.500	EY 250-4-701-1
1	SPL250	2.500-10	3.500	5.500	EY 250-4-711-1X
1	1710	2.500-10	3.500	5.156	EY 6-4-4421
1	1710	2.500-10	3.500	5.156	EY 6-4-4421-1
1	1710	2.500-10	3.500	5.156	EY 6-4-8351-1X
1	1710	2.374-46	3.500	5.840	EY 6-4-8951-1
1	1710	2.374-46	3.500	5.840	EY 6-4-8961-1X
1	1760	2.500-10	3.500	5.406	EY 6.3-4-1401-1X
1	1760	2.500-10	3.500	5.406	EY 6.3-4-1401X

Pos	Series	Spline Data	Hub Dia	* to End of Hub	End Fitting Part Number
CRD-95 (Continued)					
1	1760	2.500-10	3.500	5.406	EY 6.3-4-151
1	1760	2.500-10	3.500	5.406	EY 6.3-4-151-1
1	1810	2.500-10	3.500	5.406	EY 6.5-4-2101
1	1810	2.500-10	3.500	5.406	EY 6.5-4-2101-1
1	1810	2.500-10	3.500	5.406	EY 6.5-4-4291-1X
1	1810	2.500-10	3.500	5.406	EY 6.5-4-4291X
2	SPL170	2.250-10	3.312	5.620	EY 170-4-1301-1
2	1710	2.250-10	3.312	5.297	EY 6-4-8271-1
2	1710	2.250-10	3.312	5.297	EY 6-4-8281-1X
3	SPL170	2.250-10	3.312	5.620	EY 170-4-1301-1
3	SPL170	2.250-10	3.312	5.620	EY 170-4-1311-1X

Pos	Series	Spline Data	Hub Dia	* to End of Hub	End Fitting Part Number
CRD-96					
1	SPL170	2.500-10	3.500	5.188	EY 170-4-1341-1
1	SPL170	2.500-10	3.500	5.188	EY 170-4-1351-1X
1	SPL250	2.500-10	3.500	5.500	EY 250-4-701-1
1	SPL250	2.500-10	3.500	5.500	EY 250-4-711-1X
1	1710	2.500-10	3.500	5.156	EY 6-4-4421
1	1710	2.500-10	3.500	5.156	EY 6-4-4421-1
1	1710	2.500-10	3.500	5.156	EY 6-4-8351-1X
1	1710	2.374-46	3.500	5.840	EY 6-4-8951-1
1	1710	2.374-46	3.500	5.840	EY 6-4-8961-1X
1	1760	2.500-10	3.500	5.406	EY 6.3-4-1401-1X
1	1760	2.500-10	3.500	5.406	EY 6.3-4-1401X
1	1760	2.500-10	3.500	5.406	EY 6.3-4-151
1	1760	2.500-10	3.500	5.406	EY 6.3-4-151-1
1	1810	2.500-10	3.500	5.406	EY 6.5-4-2101
1	1810	2.500-10	3.500	5.406	EY 6.5-4-2101-1
1	1810	2.500-10	3.500	5.406	EY 6.5-4-4291-1X
1	1810	2.500-10	3.500	5.406	EY 6.5-4-4291X
2	SPL170	2.250-10	3.312	5.620	EY 170-4-1301-1
2	1710	2.250-10	3.312	5.297	EY 6-4-8271-1
2	1710	2.250-10	3.312	5.297	EY 6-4-8281-1X
2	1810	2.500-10	3.500	5.406	EY 6.5-4-4261-1X <i>All suspensions except reyco and dayton</i>
3	SPL170	2.250-10	3.312	5.620	EY 170-4-1311-1X
3	1710	2.250-10	3.312	5.297	EY 6-4-8281-1X <i>All suspensions except reyco and dayton</i>
3	1810	2.250-10	3.312	5.375	EY 6.5-4-4241-1X <i>All suspensions except reyco and dayton</i>

Pos	Series	Spline Data	Hub Dia	* to End of Hub	End Fitting Part Number
CRD-112					
1	1710	2.024-39	2.750	5.000	EY 6-4-5851-1
1	1710	2.374-46	3.500	5.840	EY 6-4-8961-1X
1	1760	2.374-46	3.500	5.375	EY 6.3-4-1391-1X
1	1760	2.374-46	3.500	5.375	EY 6.3-4-1391X
1	1760	2.374-46	3.500	5.375	EY 6.3-4-391
1	1760	2.374-46	3.500	5.375	EY 6.3-4-391-1
1	1810	2.374-46	3.500	5.406	EY 6.5-4-3251
1	1810	2.374-46	3.500	5.406	EY 6.5-4-3251-1
3	1710	2.024-39	2.750	5.000	EY 6-4-5851-1

Pos	Series	Spline Data	Hub Dia	* to End of Hub	End Fitting Part Number
CRD-113					
1	SPL170	2.374-46	3.500	5.880	EY 170-4-1211-1
1	SPL170	2.374-46	3.500	5.880	EY 170-4-1221-1X
1	SPL250	2.374-46	3.500	6.140	EY 250-4-641-1
1	SPL250	2.374-46	3.500	6.140	EY 250-4-651-1X
1	1710	2.374-46	3.500	5.156	EY 6-4-8341-1X
1	1710	2.374-46	3.500	5.840	EY 6-4-8951-1

Continued on next page

*C/L to End of Hub for EY (End Yoke); Flange Face to End of Hub for CF (Companion Flange)
 ■ Hub machined for speedometer gear



TANDEM AXLES

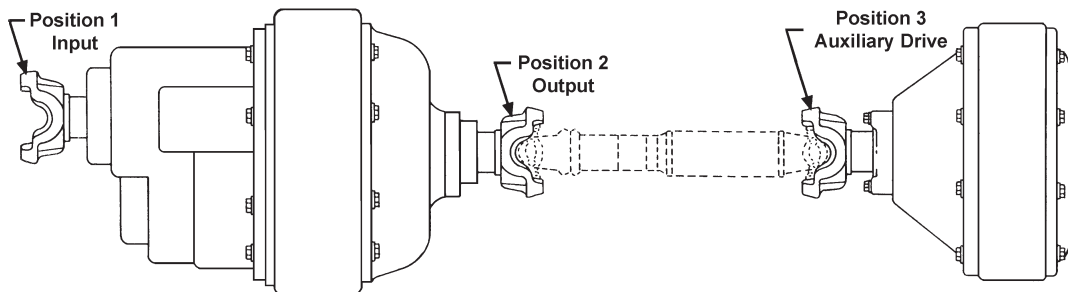

Pos	Series	Spline Data	Hub Dia	* to End of Hub	End Fitting Part Number
-----	--------	-------------	---------	-----------------	-------------------------

CRD-113 (Continued)

1	1710	2.374-46	3.500	5.840	EY 6-4-8961-1X
1	1760	2.374-46	3.500	5.375	EY 6.3-4-1391-1X
1	1760	2.374-46	3.500	5.375	EY 6.3-4-1391X
1	1810	2.374-46	3.500	5.406	EY 6.5-4-4271-1X
2	SPL170	2.024-39	2.750	5.370	EY 170-4-1251-1 <i>High angle yoke</i>
2	1710	2.024-39	2.750	5.875	EY 6-4-6571 <i>Reyco and dayton suspensions only; High angle yoke</i>
2	1710	2.024-39	2.750	5.875	EY 6-4-6571-1 <i>Reyco and dayton suspensions only; High angle yoke</i>
2	1810	2.024-39	2.750	5.188	EY 6.5-4-3261 <i>All suspensions except reyco and dayton</i>
2	1810	2.024-39	2.750	5.188	EY 6.5-4-3261-1 <i>All suspensions except reyco and dayton</i>
3	SPL170	2.024-39	2.750	5.370	EY 170-4-1251-1 <i>High angle yoke</i>
3	SPL170	2.024-39	2.750	5.370	EY 170-4-1261-1X <i>High angle yoke</i>
3	1710	2.024-39	2.750	5.000	EY 6-4-8331-1X <i>All suspensions except reyco and dayton</i>
3	1710	2.024-39	2.750	5.000	EY 6-4-8331X <i>All suspensions except reyco and dayton</i>
3	1710	2.024-39	2.750	5.875	EY 6-4-8361-1X <i>Reyco and dayton suspensions only; High angle yoke</i>
3	1710	2.024-39	2.750	5.875	EY 6-4-8361X <i>Reyco and dayton suspensions only; High angle yoke</i>
3	1810	2.024-39	2.750	5.188	EY 6.5-4-4281-1X <i>All suspensions except reyco and dayton</i>

CRD-150, CRD-151

1	SPL350	2.374-46	3.500	6.220	EY 350-4-111-1X
3	SPL170	2.750-43	3.750	5.929	EY 170-4-1931-1X
3	SPL250	2.750-43	3.750	5.500	EY 250-4-1061-1X
3	1710	2.750-43	3.750	5.929	EY 6-4-10351-1X
3	1710	2.750-43	3.750	5.929	EY 6-4-10351X

CRD-200

1	SPL170	2.374-46	3.500	5.880	EY 170-4-1211-1
1	SPL170	2.374-46	3.500	5.880	EY 170-4-1221-1X
1	SPL170	2.374-46	3.500	6.688	EY 170-4-1281-1 <i>High angle yoke</i>
1	SPL170	2.374-46	3.500	6.688	EY 170-4-1291-1X <i>High angle yoke</i>
1	SPL250	2.374-46	3.500	6.140	EY 250-4-641-1
1	SPL250	2.374-46	3.500	6.140	EY 250-4-651-1X
1	1710	2.374-46	3.500	5.156	EY 6-4-5841
1	1710	2.374-46	3.500	5.156	EY 6-4-5841-1
1	1710	2.374-46	3.500	5.156	EY 6-4-8341-1X
1	1710	2.374-46	3.500	5.156	EY 6-4-8341X
1	1760	2.374-46	3.500	5.375	EY 6.3-4-1391-1X
1	1760	2.374-46	3.500	5.375	EY 6.3-4-1391X
1	1760	2.374-46	3.500	5.375	EY 6.3-4-391

Pos	Series	Spline Data	Hub Dia	* to End of Hub	End Fitting Part Number
-----	--------	-------------	---------	-----------------	-------------------------

CRD-200 (Continued)

1	1760	2.374-46	3.500	5.375	EY 6.3-4-391-1
1	1810	2.374-46	3.500	5.406	EY 6.5-4-3251
1	1810	2.374-46	3.500	5.406	EY 6.5-4-3251-1
1	1810	2.374-46	3.500	5.406	EY 6.5-4-4271-1X
1	1810	2.374-46	3.500	5.406	EY 6.5-4-4271X
2	SPL170	2.024-39	2.750	5.370	EY 170-4-1251-1 <i>All suspensions except reyco and dayton; High angle yoke</i>
2	1610	2.024-39	2.750	4.500	EY 5-4-5881 <i>All suspensions except reyco and dayton</i>
2	1710	2.024-39	2.750	5.000	EY 6-4-5851 <i>All suspensions except reyco and dayton</i>
2	1710	2.024-39	2.750	5.000	EY 6-4-5851-1 <i>All suspensions except reyco and dayton</i>
2	1710	2.024-39	2.750	5.875	EY 6-4-6571 <i>All suspensions except reyco and dayton; High angle yoke</i>
2	1710	2.024-39	2.750	5.875	EY 6-4-6571-1 <i>All suspensions except reyco and dayton; High angle yoke</i>
2	1760	2.032-10	2.750	5.000	EY 6.3-4-421 <i>All suspensions except reyco and dayton</i>
2	1810	2.024-39	2.750	5.188	EY 6.5-4-3261 <i>All suspensions except reyco and dayton</i>
2	1810	2.024-39	2.750	5.188	EY 6.5-4-3261-1 <i>All suspensions except reyco and dayton</i>
3	SPL170	2.374-46	3.500	5.880	EY 170-4-1211-1
3	SPL170	2.374-46	3.500	5.880	EY 170-4-1221-1X
3	SPL170	2.374-46	3.500	6.688	EY 170-4-1281-1 <i>High angle yoke</i>
3	SPL170	2.374-46	3.500	6.688	EY 170-4-1291-1X <i>High angle yoke</i>
3	SPL250	2.374-46	3.500	6.140	EY 250-4-641-1
3	SPL250	2.374-46	3.500	6.140	EY 250-4-651-1X
3	1710	2.374-46	3.500	5.156	EY 6-4-5841
3	1710	2.374-46	3.500	5.156	EY 6-4-5841-1
3	1710	2.374-46	3.500	5.156	EY 6-4-8341-1X
3	1710	2.374-46	3.500	5.156	EY 6-4-8341X
3	1760	2.374-46	3.500	5.375	EY 6.3-4-1391-1X
3	1760	2.374-46	3.500	5.375	EY 6.3-4-1391X
3	1760	2.374-46	3.500	5.375	EY 6.3-4-391
3	1760	2.374-46	3.500	5.375	EY 6.3-4-391-1
3	1810	2.374-46	3.500	5.406	EY 6.5-4-3251
3	1810	2.374-46	3.500	5.406	EY 6.5-4-3251-1
3	1810	2.374-46	3.500	5.406	EY 6.5-4-4271-1X
3	1810	2.374-46	3.500	5.406	EY 6.5-4-4271X

CRD-201

1	1710	2.374-46	3.500	5.156	EY 6-4-8341-1X
1	1710	2.374-46	3.500	5.840	EY 6-4-8951-1
1	1710	2.374-46	3.500	5.840	EY 6-4-8961-1X
1	1760	2.374-46	3.500	5.375	EY 6.3-4-1391-1X
1	1760	2.374-46	3.500	5.375	EY 6.3-4-1391X

*C/L to End of Hub for EY (End Yoke); Flange Face to End of Hub for CF (Companion Flange)

■ Hub machined for speedometer gear





Pos	Series	Spline Data	Hub Dia	* to End of Hub	End Fitting Part Number
CRD-201 (Continued)					
1	1810	2.374-46	3.500	5.406	EY 6.5-4-4271-1X
2	1810	2.024-39	2.750	5.188	EY 6.5-4-3261
		<i>All suspensions except reyco and dayton</i>			
2	1810	2.024-39	2.750	5.188	EY 6.5-4-3261-1
		<i>All suspensions except reyco and dayton</i>			
3	1710	2.024-39	2.750	5.000	EY 6-4-8331-1X
		<i>All suspensions except reyco and dayton</i>			
3	1710	2.024-39	2.750	5.000	EY 6-4-8331X
		<i>All suspensions except reyco and dayton</i>			
3	1810	2.374-46	3.500	5.406	EY 6.5-4-4271-1X
		<i>All suspensions except reyco and dayton</i>			

CRD-203					
1	1710	2.374-46	3.500	5.156	EY 6-4-8341-1X
1	1710	2.374-46	3.500	5.840	EY 6-4-8951-1
1	1710	2.374-46	3.500	5.840	EY 6-4-8961-1X
1	1760	2.374-46	3.500	5.375	EY 6.3-4-1391-1X
1	1760	2.374-46	3.500	5.375	EY 6.3-4-1391X
3	1710	2.024-39	2.750	5.000	EY 6-4-8331-1X
		<i>All suspensions except reyco and dayton</i>			
3	1710	2.024-39	2.750	5.000	EY 6-4-8331X
		<i>All suspensions except reyco and dayton</i>			
3	1810	2.374-46	3.500	5.406	EY 6.5-4-4271-1X
		<i>All suspensions except reyco and dayton</i>			

CRDP-95					
1	SPL170	2.374-46	3.500	5.880	EY 170-4-1211-1
1	SPL170	2.374-46	3.500	5.880	EY 170-4-1221-1X
1	SPL250	2.374-46	3.500	6.140	EY 250-4-641-1
1	SPL250	2.374-46	3.500	6.140	EY 250-4-651-1X
1	1710	2.500-10	3.500	5.156	EY 6-4-8351-1X
1	1760	2.500-10	3.500	5.406	EY 6.3-4-1401-1X
1	1760	2.500-10	3.500	5.406	EY 6.3-4-1401X
1	1760	2.500-10	3.500	5.406	EY 6.3-4-151
1	1760	2.500-10	3.500	5.406	EY 6.3-4-151-1
2	SPL170	2.024-39	2.750	5.370	EY 170-4-1251-1
		<i>High angle yoke</i>			
2	1710	2.250-10	3.312	5.297	EY 6-4-8281-1X
		<i>All suspensions except reyco and dayton</i>			
2	1810	2.500-10	3.500	5.406	EY 6.5-4-4261-1X
		<i>All suspensions except reyco and dayton</i>			
3	SPL170	2.024-39	2.750	5.370	EY 170-4-1251-1
		<i>High angle yoke</i>			
3	SPL170	2.024-39	2.750	5.370	EY 170-4-1261-1X
		<i>High angle yoke</i>			
3	1710	2.250-10	3.312	5.297	EY 6-4-8281-1X
		<i>All suspensions except reyco and dayton</i>			
3	1810	2.250-10	3.312	5.375	EY 6.5-4-4241-1X
		<i>All suspensions except reyco and dayton</i>			

CRDPC-92					
1	1710	2.374-46	3.500	5.156	EY 6-4-8341-1X
1	1710	2.374-46	3.500	5.840	EY 6-4-8951-1
1	1710	2.374-46	3.500	5.840	EY 6-4-8961-1X
1	1760	2.374-46	3.500	5.375	EY 6.3-4-1391-1X
1	1760	2.374-46	3.500	5.375	EY 6.3-4-1391X
1	1810	2.374-46	3.500	5.406	EY 6.5-4-4271-1X
2	1710	2.024-39	2.750	5.875	EY 6-4-6571
		<i>Reyco and dayton suspensions only; High angle yoke</i>			
2	1710	2.024-39	2.750	5.875	EY 6-4-6571-1
		<i>Reyco and dayton suspensions only; High angle yoke</i>			
2	1810	2.024-39	2.750	5.188	EY 6.5-4-3261
		<i>All suspensions except reyco and dayton</i>			
2	1810	2.024-39	2.750	5.188	EY 6.5-4-3261-1
		<i>All suspensions except reyco and dayton</i>			

Pos	Series	Spline Data	Hub Dia	* to End of Hub	End Fitting Part Number
CRDPC-92 (Continued)					
3	1710	2.024-39	2.750	5.000	EY 6-4-8331-1X
		<i>All suspensions w/9.59 ratio, exc. reyco and dayton</i>			
3	1710	2.024-39	2.750	5.000	EY 6-4-8331X
		<i>All suspensions w/9.59 ratio, exc. reyco and dayton</i>			
3	1710	2.024-39	2.750	5.875	EY 6-4-8361-1X
		<i>Reyco and dayton suspensions only; High angle yoke</i>			
3	1710	2.024-39	2.750	5.875	EY 6-4-8361X
		<i>Reyco and dayton suspensions only; High angle yoke</i>			
3	1810	2.024-39	2.750	5.188	EY 6.5-4-4281-1X
		<i>All suspensions except reyco and dayton</i>			

CRDPC-93					
1	1710	2.374-46	3.500	5.840	EY 6-4-8961-1X
CRDPC-112					
1	1710	2.374-46	3.500	5.156	EY 6-4-8341-1X
1	1710	2.374-46	3.500	5.840	EY 6-4-8951-1
1	1710	2.374-46	3.500	5.840	EY 6-4-8961-1X
1	1760	2.374-46	3.500	5.375	EY 6.3-4-1391-1X
1	1760	2.374-46	3.500	5.375	EY 6.3-4-1391X
1	1810	2.374-46	3.500	5.406	EY 6.5-4-4271-1X
2	1710	2.024-39	2.750	5.875	EY 6-4-6571
		<i>Reyco and dayton suspensions only; High angle yoke</i>			
2	1710	2.024-39	2.750	5.875	EY 6-4-6571-1
		<i>Reyco and dayton suspensions only; High angle yoke</i>			
2	1810	2.024-39	2.750	5.188	EY 6.5-4-3261
		<i>All suspensions except reyco and dayton</i>			
2	1810	2.024-39	2.750	5.188	EY 6.5-4-3261-1
		<i>All suspensions except reyco and dayton</i>			
3	1710	2.024-39	2.750	5.000	EY 6-4-8331-1X
		<i>All suspensions w/9.59 ratio, exc. reyco and dayton</i>			
3	1710	2.024-39	2.750	5.000	EY 6-4-8331X
		<i>All suspensions w/9.59 ratio, exc. reyco and dayton</i>			
3	1710	2.024-39	2.750	5.875	EY 6-4-8361-1X
		<i>Reyco and dayton suspensions only; High angle yoke</i>			
3	1710	2.024-39	2.750	5.875	EY 6-4-8361X
		<i>Reyco and dayton suspensions only; High angle yoke</i>			
3	1810	2.024-39	2.750	5.188	EY 6.5-4-4281-1X
		<i>All suspensions except reyco and dayton</i>			

CRDPC-200, CRDPC-202					
1	1710	2.374-46	3.500	5.156	EY 6-4-8341-1X
1	1710	2.374-46	3.500	5.840	EY 6-4-8951-1
1	1710	2.374-46	3.500	5.840	EY 6-4-8961-1X
1	1760	2.374-46	3.500	5.375	EY 6.3-4-1391-1X
1	1760	2.374-46	3.500	5.375	EY 6.3-4-1391X
1	1810	2.374-46	3.500	5.406	EY 6.5-4-4271-1X
2	1810	2.024-39	2.750	5.188	EY 6.5-4-3261
		<i>All suspensions except reyco and dayton</i>			
2	1810	2.024-39	2.750	5.188	EY 6.5-4-3261-1
		<i>All suspensions except reyco and dayton</i>			
3	1710	2.024-39	2.750	5.000	EY 6-4-8331-1X
		<i>All suspensions except reyco and dayton</i>			
3	1710	2.024-39	2.750	5.000	EY 6-4-8331X
		<i>All suspensions except reyco and dayton</i>			
3	1810	2.374-46	3.500	5.406	EY 6.5-4-4271-1X
		<i>All suspensions except reyco and dayton</i>			

CRDPL-112, CRDPL-200, CRDPL-202					
1	SPL170	2.374-46	3.500	5.880	EY 170-4-1211-1
1	SPL170	2.374-46	3.500	5.880	EY 170-4-1221-1X
1	SPL250	2.374-46	3.500	6.140	EY 250-4-641-1
1	SPL250	2.374-46	3.500	6.140	EY 250-4-651-1X
1	1710	2.500-10	3.500	5.156	EY 6-4-8351-1X
		<i>All suspensions except reyco and dayton</i>			

Continued on next page

*C/L to End of Hub for EY (End Yoke); Flange Face to End of Hub for CF (Companion Flange)

■ Hub machined for speedometer gear



Important: See Safety Information in General Information Section (J300P-GI)

TANDEM AXLES

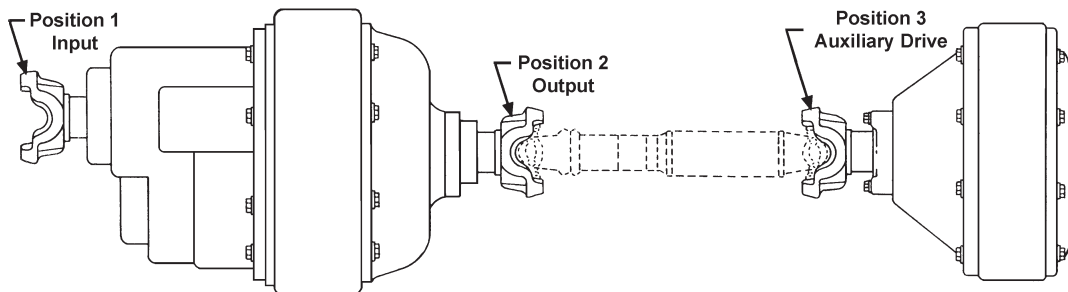

Pos	Series	Spline Data	Hub Dia	* to End of Hub	End Fitting Part Number
-----	--------	-------------	---------	-----------------	-------------------------

CRDPL-112, CRDPL-200, CRDPL-202 (Continued)

1	1760	2.500-10	3.500	5.406	EY 6.3-4-1401-1X
2	SPL170	2.024-39	2.750	5.370	EY 170-4-1251-1 <i>High angle yoke</i>
2	1710	2.250-10	3.312	5.297	EY 6-4-8281-1X
2	1810	2.500-10	3.500	5.406	EY 6.5-4-4261-1X
3	SPL170	2.024-39	2.750	5.370	EY 170-4-1251-1 <i>High angle yoke</i>
3	SPL170	2.024-39	2.750	5.370	EY 170-4-1261-1X <i>High angle yoke</i>
3	1710	2.250-10	3.312	5.297	EY 6-4-8281-1X
3	1810	2.250-10	3.312	5.375	EY 6.5-4-4241-1X

EW-48C, EW-48W, EW-60C

1	1710	2.374-46	3.500	5.156	EY 6-4-5841
1	1710	2.374-46	3.500	5.156	EY 6-4-8341-1X
1	1760	2.374-46	3.500	5.375	EY 6.3-4-1391-1X
1	1760	2.374-46	3.500	5.375	EY 6.3-4-391
1	1760	2.374-46	3.500	5.375	EY 6.3-4-391-1
1	1810	2.374-46	3.500	5.406	EY 6.5-4-3251
1	1810	2.374-46	3.500	5.406	EY 6.5-4-4271-1X
2	1610	2.024-39	2.750	4.500	EY 5-4-5881
2	1710	2.024-39	2.750	5.000	EY 6-4-5851
2	1710	2.024-39	2.750	5.875	EY 6-4-6571 <i>High angle yoke</i>
2	1810	2.024-39	2.750	5.188	EY 6.5-4-3261
3	1610	2.024-39	2.750	4.500	EY 5-4-5881
3	1710	2.024-39	2.750	5.000	EY 6-4-5851
3	1710	2.024-39	2.750	5.875	EY 6-4-6571 <i>High angle yoke</i>
3	1810	2.024-39	2.750	5.188	EY 6.5-4-3261

GWS-592

1	1710	2.500-10	3.500	5.156	EY 6-4-4421
1	1710	2.500-10	3.500	5.156	EY 6-4-8351-1X
1	1810	2.500-10	3.500	5.406	EY 6.5-4-2101
2	1710	2.250-10	3.125	5.250	EY 6-4-2441
2	1810	2.250-10	3.125	5.375	EY 6.5-4-2141
2	1810	2.250-10	3.125	5.375	EY 6.5-4-4221-1X

SA-38C

1	1710	2.374-46	3.500	5.156	EY 6-4-5841
1	1710	2.374-46	3.500	5.156	EY 6-4-8341-1X
1	1760	2.374-46	3.500	5.375	EY 6.3-4-1391-1X
1	1760	2.374-46	3.500	5.375	EY 6.3-4-391
1	1810	2.374-46	3.500	5.406	EY 6.5-4-3251
1	1810	2.374-46	3.500	5.406	EY 6.5-4-4271-1X
2	1610	2.024-39	2.750	4.500	EY 5-4-5881
2	1710	2.024-39	2.750	5.000	EY 6-4-5851
2	1710	2.024-39	2.750	5.875	EY 6-4-6571 <i>High angle yoke</i>
2	1710	2.024-39	2.750	5.000	EY 6-4-8331-1X

Pos	Series	Spline Data	Hub Dia	* to End of Hub	End Fitting Part Number
-----	--------	-------------	---------	-----------------	-------------------------

SA-38C (Continued)

2	1710	2.024-39	2.750	5.875	EY 6-4-8361-1X <i>High angle yoke</i>
2	1810	2.024-39	2.750	5.188	EY 6.5-4-3261
2	1810	2.024-39	2.750	5.188	EY 6.5-4-4281-1X
3	1610	2.024-39	2.750	4.500	EY 5-4-5881
3	1710	2.024-39	2.750	5.000	EY 6-4-5851
3	1710	2.024-39	2.750	5.875	EY 6-4-6571 <i>High angle yoke</i>
3	1710	2.024-39	2.750	5.000	EY 6-4-8331-1X
3	1710	2.024-39	2.750	5.875	EY 6-4-8361-1X <i>High angle yoke</i>
3	1810	2.024-39	2.750	5.188	EY 6.5-4-3261
3	1810	2.024-39	2.750	5.188	EY 6.5-4-4281-1X

SA-38W

1	SPL170	2.374-46	3.500	5.880	EY 170-4-1211-1
1	SPL170	2.374-46	3.500	5.880	EY 170-4-1221-1X
1	SPL250	2.374-46	3.500	6.140	EY 250-4-641-1
1	SPL250	2.374-46	3.500	6.140	EY 250-4-651-1X
1	1710	2.374-46	3.500	5.156	EY 6-4-5841
1	1710	2.374-46	3.500	5.156	EY 6-4-8341-1X
1	1760	2.374-46	3.500	5.375	EY 6.3-4-1391-1X
1	1760	2.374-46	3.500	5.375	EY 6.3-4-391
1	1810	2.374-46	3.500	5.406	EY 6.5-4-3251
1	1810	2.374-46	3.500	5.406	EY 6.5-4-4271-1X
2	SPL170	2.024-39	2.750	5.370	EY 170-4-1251-1 <i>High angle yoke</i>
2	1610	2.024-39	2.750	4.500	EY 5-4-5881
2	1710	2.024-39	2.750	5.000	EY 6-4-5851
2	1710	2.024-39	2.750	5.875	EY 6-4-6571 <i>High angle yoke</i>
2	1710	2.024-39	2.750	5.000	EY 6-4-8331-1X
2	1710	2.024-39	2.750	5.875	EY 6-4-8361-1X <i>High angle yoke</i>
3	SPL170	2.024-39	2.750	5.370	EY 170-4-1261-1X <i>High angle yoke</i>
3	1610	2.024-39	2.750	4.500	EY 5-4-5881
3	1710	2.024-39	2.750	5.000	EY 6-4-5851
3	1710	2.024-39	2.750	5.875	EY 6-4-6571 <i>High angle yoke</i>
3	1710	2.024-39	2.750	5.000	EY 6-4-8331-1X
3	1710	2.024-39	2.750	5.875	EY 6-4-8361-1X <i>High angle yoke</i>
3	1810	2.024-39	2.750	5.188	EY 6.5-4-3261
3	1810	2.024-39	2.750	5.188	EY 6.5-4-4281-1X

*C/L to End of Hub for EY (End Yoke); Flange Face to End of Hub for CF (Companion Flange)

■ Hub machined for speedometer gear



Pos	Series	Spline Data	Hub Dia	* to End of Hub	End Fitting Part Number
SC-38C, SC-38W					
1	1710	2.374-46	3.500	5.156	EY 6-4-5841
1	1710	2.374-46	3.500	5.156	EY 6-4-8341-1X
1	1760	2.374-46	3.500	5.375	EY 6.3-4-1391-1X
1	1760	2.374-46	3.500	5.375	EY 6.3-4-391
1	1810	2.374-46	3.500	5.406	EY 6.5-4-3251
1	1810	2.374-46	3.500	5.406	EY 6.5-4-4271-1X
2	1610	2.024-39	2.750	4.500	EY 5-4-5881
2	1710	2.024-39	2.750	5.000	EY 6-4-5851
2	1710	2.024-39	2.750	5.875	EY 6-4-6571
					<i>High angle yoke</i>
2	1710	2.024-39	2.750	5.000	EY 6-4-8331-1X
2	1710	2.024-39	2.750	5.875	EY 6-4-8361-1X
					<i>High angle yoke</i>
2	1810	2.024-39	2.750	5.188	EY 6.5-4-3261
2	1810	2.024-39	2.750	5.188	EY 6.5-4-4281-1X
3	1610	2.024-39	2.750	4.500	EY 5-4-5881
3	1710	2.024-39	2.750	5.000	EY 6-4-5851
3	1710	2.024-39	2.750	5.875	EY 6-4-6571
					<i>High angle yoke</i>
3	1710	2.024-39	2.750	5.000	EY 6-4-8331-1X
3	1710	2.024-39	2.750	5.875	EY 6-4-8361-1X
					<i>High angle yoke</i>
3	1810	2.024-39	2.750	5.188	EY 6.5-4-3261
3	1810	2.024-39	2.750	5.188	EY 6.5-4-4281-1X

Pos	Series	Spline Data	Hub Dia	* to End of Hub	End Fitting Part Number
SC-342C					
1	SPL170	2.374-46	3.500	5.880	EY 170-4-1211-1
1	SPL170	2.374-46	3.500	5.880	EY 170-4-1221-1X
1	SPL250	2.374-46	3.500	6.140	EY 250-4-641-1
1	SPL250	2.374-46	3.500	6.140	EY 250-4-651-1X
1	1710	2.374-46	3.500	5.156	EY 6-4-5841
1	1710	2.374-46	3.500	5.156	EY 6-4-8341-1X
1	1760	2.374-46	3.500	5.375	EY 6.3-4-1391-1X
1	1760	2.374-46	3.500	5.375	EY 6.3-4-391
1	1810	2.374-46	3.500	5.406	EY 6.5-4-3251
1	1810	2.374-46	3.500	5.406	EY 6.5-4-4271-1X
2	SPL170	2.024-39	2.750	5.370	EY 170-4-1251-1
					<i>High angle yoke</i>
2	1610	2.024-39	2.750	4.500	EY 5-4-5881
2	1710	2.024-39	2.750	5.000	EY 6-4-5851
2	1710	2.024-39	2.750	5.875	EY 6-4-6571
					<i>High angle yoke</i>
2	1710	2.024-39	2.750	5.000	EY 6-4-8331-1X
2	1710	2.024-39	2.750	5.875	EY 6-4-8361-1X
					<i>High angle yoke</i>
2	1810	2.024-39	2.750	5.188	EY 6.5-4-3261
2	1810	2.024-39	2.750	5.188	EY 6.5-4-4281-1X
3	SPL170	2.024-39	2.750	5.370	EY 170-4-1251-1
					<i>High angle yoke</i>
3	SPL170	2.024-39	2.750	5.370	EY 170-4-1261-1X
					<i>High angle yoke</i>
3	1610	2.024-39	2.750	4.500	EY 5-4-5881
3	1710	2.024-39	2.750	5.000	EY 6-4-5851
3	1710	2.024-39	2.750	5.875	EY 6-4-6571
					<i>High angle yoke</i>
3	1710	2.024-39	2.750	5.000	EY 6-4-8331-1X
3	1710	2.024-39	2.750	5.875	EY 6-4-8361-1X
					<i>High angle yoke</i>
3	1810	2.024-39	2.750	5.188	EY 6.5-4-3261
3	1810	2.024-39	2.750	5.188	EY 6.5-4-4281-1X

Pos	Series	Spline Data	Hub Dia	* to End of Hub	End Fitting Part Number
SC-342W					
1	1710	2.374-46	3.500	5.156	EY 6-4-5841
1	1710	2.374-46	3.500	5.156	EY 6-4-8341-1X
1	1760	2.374-46	3.500	5.375	EY 6.3-4-1391-1X
1	1760	2.374-46	3.500	5.375	EY 6.3-4-391
1	1810	2.374-46	3.500	5.406	EY 6.5-4-3251
1	1810	2.374-46	3.500	5.406	EY 6.5-4-4271-1X
2	1610	2.024-39	2.750	4.500	EY 5-4-5881
2	1710	2.024-39	2.750	5.000	EY 6-4-5851
2	1710	2.024-39	2.750	5.875	EY 6-4-6571
					<i>High angle yoke</i>
2	1710	2.024-39	2.750	5.000	EY 6-4-8331-1X
2	1710	2.024-39	2.750	5.875	EY 6-4-8361-1X
					<i>High angle yoke</i>
2	1810	2.024-39	2.750	5.188	EY 6.5-4-3261
2	1810	2.024-39	2.750	5.188	EY 6.5-4-4281-1X
3	1610	2.024-39	2.750	4.500	EY 5-4-5881
3	1710	2.024-39	2.750	5.000	EY 6-4-5851
3	1710	2.024-39	2.750	5.875	EY 6-4-6571
					<i>High angle yoke</i>
3	1710	2.024-39	2.750	5.000	EY 6-4-8331-1X
3	1710	2.024-39	2.750	5.875	EY 6-4-8361-1X
					<i>High angle yoke</i>
3	1810	2.024-39	2.750	5.188	EY 6.5-4-3261
3	1810	2.024-39	2.750	5.188	EY 6.5-4-4281-1X

Pos	Series	Spline Data	Hub Dia	* to End of Hub	End Fitting Part Number
SH-34C, SH-34W,					
1	1710	2.374-46	3.500	5.156	EY 6-4-5841
1	1710	2.374-46	3.500	5.156	EY 6-4-8341-1X
1	1760	2.374-46	3.500	5.375	EY 6.3-4-1391-1X
1	1760	2.374-46	3.500	5.375	EY 6.3-4-391
1	1810	2.374-46	3.500	5.406	EY 6.5-4-3251
1	1810	2.374-46	3.500	5.406	EY 6.5-4-4271-1X
2	1610	2.024-39	2.750	4.500	EY 5-4-5881
2	1710	2.024-39	2.750	5.000	EY 6-4-5851
2	1710	2.024-39	2.750	5.875	EY 6-4-6571
					<i>High angle yoke</i>
2	1710	2.024-39	2.750	5.000	EY 6-4-8331-1X
2	1710	2.024-39	2.750	5.875	EY 6-4-8361-1X
					<i>High angle yoke</i>
2	1810	2.024-39	2.750	5.188	EY 6.5-4-3261
2	1810	2.024-39	2.750	5.188	EY 6.5-4-4281-1X
3	1610	2.024-39	2.750	4.500	EY 5-4-5881
3	1710	2.024-39	2.750	5.000	EY 6-4-5851
3	1710	2.024-39	2.750	5.875	EY 6-4-6571
					<i>High angle yoke</i>
3	1710	2.024-39	2.750	5.000	EY 6-4-8331-1X
3	1710	2.024-39	2.750	5.875	EY 6-4-8361-1X
					<i>High angle yoke</i>
3	1810	2.024-39	2.750	5.188	EY 6.5-4-3261
3	1810	2.024-39	2.750	5.188	EY 6.5-4-4281-1X

Pos	Series	Spline Data	Hub Dia	* to End of Hub	End Fitting Part Number
SH-38C					
1	SPL170	2.374-46	3.500	5.880	EY 170-4-1211-1
1	SPL170	2.374-46	3.500	5.880	EY 170-4-1221-1X
1	SPL250	2.374-46	3.500	6.140	EY 250-4-641-1
1	SPL250	2.374-46	3.500	6.140	EY 250-4-651-1X
1	1710	2.374-46	3.500	5.156	EY 6-4-5841
1	1710	2.374-46	3.500	5.156	EY 6-4-8341-1X
1	1760	2.374-46	3.500	5.375	EY 6.3-4-1391-1X
1	1760	2.374-46	3.500	5.375	EY 6.3-4-391

Continued on next page

*C/L to End of Hub for EY (End Yoke); Flange Face to End of Hub for CF (Companion Flange)

■ Hub machined for speedometer gear



Important: See Safety Information in General Information Section (J300P-GI)

TANDEM AXLES

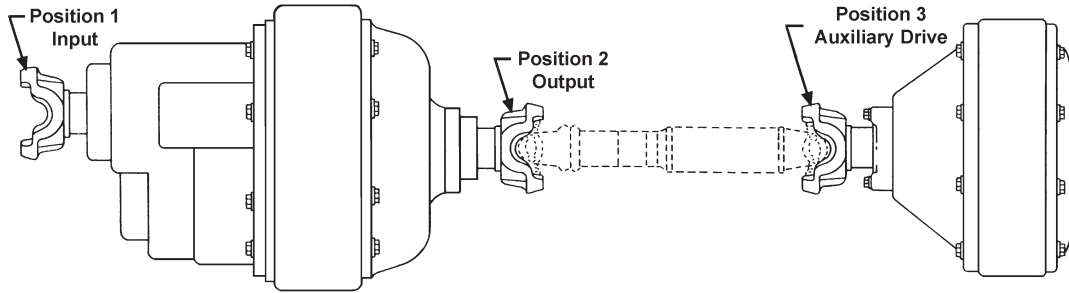

Pos	Series	Spline Data	Hub Dia	* to End of Hub	End Fitting Part Number
-----	--------	-------------	---------	-----------------	-------------------------

SH-38C (Continued)

1	1810	2.374-46	3.500	5.406	EY 6.5-4-3251
1	1810	2.374-46	3.500	5.406	EY 6.5-4-4271-1X
2	SPL170	2.024-39	2.750	5.370	EY 170-4-1251-1 <i>High angle yoke</i>
2	1610	2.024-39	2.750	4.500	EY 5-4-5881
2	1710	2.024-39	2.750	5.000	EY 6-4-5851
2	1710	2.024-39	2.750	5.875	EY 6-4-6571 <i>High angle yoke</i>
2	1710	2.024-39	2.750	5.000	EY 6-4-8331-1X
2	1710	2.024-39	2.750	5.875	EY 6-4-8361-1X <i>High angle yoke</i>
2	1810	2.024-39	2.750	5.188	EY 6.5-4-3261
2	1810	2.024-39	2.750	5.188	EY 6.5-4-4281-1X
3	SPL170	2.024-39	2.750	5.370	EY 170-4-1251-1 <i>High angle yoke</i>
3	SPL170	2.024-39	2.750	5.370	EY 170-4-1261-1X <i>High angle yoke</i>
3	1610	2.024-39	2.750	4.500	EY 5-4-5881
3	1710	2.024-39	2.750	5.000	EY 6-4-5851
3	1710	2.024-39	2.750	5.875	EY 6-4-6571 <i>High angle yoke</i>
3	1710	2.024-39	2.750	5.000	EY 6-4-8331-1X
3	1710	2.024-39	2.750	5.875	EY 6-4-8361-1X <i>High angle yoke</i>
3	1810	2.024-39	2.750	5.188	EY 6.5-4-3261
3	1810	2.024-39	2.750	5.188	EY 6.5-4-4281-1X

SH-38W, SH-342C, SH-342W

1	1710	2.374-46	3.500	5.156	EY 6-4-5841
1	1710	2.374-46	3.500	5.156	EY 6-4-8341-1X
1	1760	2.374-46	3.500	5.375	EY 6.3-4-1391-1X
1	1760	2.374-46	3.500	5.375	EY 6.3-4-391
1	1810	2.374-46	3.500	5.406	EY 6.5-4-3251
1	1810	2.374-46	3.500	5.406	EY 6.5-4-4271-1X
2	1610	2.024-39	2.750	4.500	EY 5-4-5881
2	1710	2.024-39	2.750	5.000	EY 6-4-5851
2	1710	2.024-39	2.750	5.875	EY 6-4-6571 <i>High angle yoke</i>
2	1710	2.024-39	2.750	5.000	EY 6-4-8331-1X
2	1710	2.024-39	2.750	5.875	EY 6-4-8361-1X <i>High angle yoke</i>
2	1810	2.024-39	2.750	5.188	EY 6.5-4-3261
2	1810	2.024-39	2.750	5.188	EY 6.5-4-4281-1X
3	1610	2.024-39	2.750	4.500	EY 5-4-5881
3	1710	2.024-39	2.750	5.000	EY 6-4-5851
3	1710	2.024-39	2.750	5.875	EY 6-4-6571 <i>High angle yoke</i>
3	1710	2.024-39	2.750	5.000	EY 6-4-8331-1X
3	1710	2.024-39	2.750	5.875	EY 6-4-8361-1X <i>High angle yoke</i>
3	1810	2.024-39	2.750	5.188	EY 6.5-4-3261
3	1810	2.024-39	2.750	5.188	EY 6.5-4-4281-1X

Pos	Series	Spline Data	Hub Dia	* to End of Hub	End Fitting Part Number
-----	--------	-------------	---------	-----------------	-------------------------

SH-440C, SH-441C

1	1710	2.374-46	3.500	5.156	EY 6-4-5841
1	1710	2.374-46	3.500	5.156	EY 6-4-8341-1X
1	1760	2.374-46	3.500	5.375	EY 6.3-4-1391-1X
1	1760	2.374-46	3.500	5.375	EY 6.3-4-391
1	1810	2.374-46	3.500	5.406	EY 6.5-4-3251
1	1810	2.374-46	3.500	5.406	EY 6.5-4-4271-1X
2	1610	2.024-39	2.750	4.500	EY 5-4-5881
2	1710	2.024-39	2.750	5.000	EY 6-4-5851
2	1710	2.024-39	2.750	5.875	EY 6-4-6571 <i>High angle yoke</i>
2	1810	2.024-39	2.750	5.188	EY 6.5-4-3261
3	1610	2.024-39	2.750	4.500	EY 5-4-5881
3	1710	2.024-39	2.750	5.000	EY 6-4-5851
3	1710	2.024-39	2.750	5.875	EY 6-4-6571 <i>High angle yoke</i>
3	1810	2.024-39	2.750	5.188	EY 6.5-4-3261

SHB-38C, SHB-38W, SHB-342C, SHB-342W, SS-34C, SS-34W, SS-38C, SS-38W

1	1710	2.374-46	3.500	5.156	EY 6-4-5841
1	1710	2.374-46	3.500	5.156	EY 6-4-8341-1X
1	1760	2.374-46	3.500	5.375	EY 6.3-4-1391-1X
1	1760	2.374-46	3.500	5.375	EY 6.3-4-391
1	1810	2.374-46	3.500	5.406	EY 6.5-4-3251
1	1810	2.374-46	3.500	5.406	EY 6.5-4-4271-1X
2	1610	2.024-39	2.750	4.500	EY 5-4-5881
2	1710	2.024-39	2.750	5.000	EY 6-4-5851
2	1710	2.024-39	2.750	5.875	EY 6-4-6571 <i>High angle yoke</i>
2	1710	2.024-39	2.750	5.000	EY 6-4-8331-1X
2	1710	2.024-39	2.750	5.875	EY 6-4-8361-1X <i>High angle yoke</i>
2	1810	2.024-39	2.750	5.188	EY 6.5-4-3261
2	1810	2.024-39	2.750	5.188	EY 6.5-4-4281-1X
3	1610	2.024-39	2.750	4.500	EY 5-4-5881
3	1710	2.024-39	2.750	5.000	EY 6-4-5851
3	1710	2.024-39	2.750	5.875	EY 6-4-6571 <i>High angle yoke</i>
3	1710	2.024-39	2.750	5.000	EY 6-4-8331-1X
3	1710	2.024-39	2.750	5.875	EY 6-4-8361-1X <i>High angle yoke</i>
3	1810	2.024-39	2.750	5.188	EY 6.5-4-3261
3	1810	2.024-39	2.750	5.188	EY 6.5-4-4281-1X

SS-50C, SS-58C

1	1710	2.374-46	3.500	5.156	EY 6-4-5841
1	1710	2.374-46	3.500	5.156	EY 6-4-8341-1X
1	1760	2.374-46	3.500	5.375	EY 6.3-4-1391-1X
1	1760	2.374-46	3.500	5.375	EY 6.3-4-391
1	1810	2.374-46	3.500	5.406	EY 6.5-4-3251
1	1810	2.374-46	3.500	5.406	EY 6.5-4-4271-1X

*C/L to End of Hub for EY (End Yoke); Flange Face to End of Hub for CF (Companion Flange)

■ Hub machined for speedometer gear



Pos	Series	Spline Data	Hub Dia	* to End of Hub	End Fitting Part Number
-----	--------	-------------	---------	-----------------	-------------------------

Pos	Series	Spline Data	Hub Dia	* to End of Hub	End Fitting Part Number
-----	--------	-------------	---------	-----------------	-------------------------

SS-50C, SS-58C (Continued)

2	1610	2.024-39	2.750	4.500	EY 5-4-5881
2	1710	2.024-39	2.750	5.000	EY 6-4-5851
2	1710	2.024-39	2.750	5.875	EY 6-4-6571 <i>High angle yoke</i>
2	1810	2.024-39	2.750	5.188	EY 6.5-4-3261
3	1610	2.024-39	2.750	4.500	EY 5-4-5881
3	1710	2.024-39	2.750	5.000	EY 6-4-5851
3	1710	2.024-39	2.750	5.875	EY 6-4-6571 <i>High angle yoke</i>
3	1810	2.024-39	2.750	5.188	EY 6.5-4-3261

SS-65C, SS-65W

1	1760	2.500-10	3.500	5.406	EY 6.3-4-1401-1X
1	1760	2.500-10	3.500	5.406	EY 6.3-4-151
2	1710	2.250-10	3.125	5.250	EY 6-4-2441
3	1710	2.250-10	3.125	5.250	EY 6-4-2441

SS-342C, SS-342W

1	1710	2.374-46	3.500	5.156	EY 6-4-5841
1	1710	2.374-46	3.500	5.156	EY 6-4-8341-1X
1	1760	2.374-46	3.500	5.375	EY 6.3-4-1391-1X
1	1760	2.374-46	3.500	5.375	EY 6.3-4-391
1	1810	2.374-46	3.500	5.406	EY 6.5-4-3251
1	1810	2.374-46	3.500	5.406	EY 6.5-4-4271-1X
2	1610	2.024-39	2.750	4.500	EY 5-4-5881
2	1710	2.024-39	2.750	5.000	EY 6-4-5851
2	1710	2.024-39	2.750	5.875	EY 6-4-6571 <i>High angle yoke</i>
2	1710	2.024-39	2.750	5.000	EY 6-4-8331-1X
2	1710	2.024-39	2.750	5.875	EY 6-4-8361-1X <i>High angle yoke</i>
2	1810	2.024-39	2.750	5.188	EY 6.5-4-3261
2	1810	2.024-39	2.750	5.188	EY 6.5-4-4281-1X
3	1610	2.024-39	2.750	4.500	EY 5-4-5881
3	1710	2.024-39	2.750	5.000	EY 6-4-5851
3	1710	2.024-39	2.750	5.875	EY 6-4-6571 <i>High angle yoke</i>
3	1710	2.024-39	2.750	5.000	EY 6-4-8331-1X
3	1710	2.024-39	2.750	5.875	EY 6-4-8361-1X <i>High angle yoke</i>
3	1810	2.024-39	2.750	5.188	EY 6.5-4-3261
3	1810	2.024-39	2.750	5.188	EY 6.5-4-4281-1X

SS-440C, SS-441C

1	1710	2.374-46	3.500	5.156	EY 6-4-5841
1	1710	2.374-46	3.500	5.156	EY 6-4-8341-1X
1	1760	2.374-46	3.500	5.375	EY 6.3-4-1391-1X
1	1760	2.374-46	3.500	5.375	EY 6.3-4-391
1	1810	2.374-46	3.500	5.406	EY 6.5-4-3251
1	1810	2.374-46	3.500	5.406	EY 6.5-4-4271-1X
2	1610	2.024-39	2.750	4.500	EY 5-4-5881
2	1710	2.024-39	2.750	5.000	EY 6-4-5851
2	1710	2.024-39	2.750	5.875	EY 6-4-6571 <i>High angle yoke</i>
2	1810	2.024-39	2.750	5.188	EY 6.5-4-3261
3	1610	2.024-39	2.750	4.500	EY 5-4-5881
3	1710	2.024-39	2.750	5.000	EY 6-4-5851
3	1710	2.024-39	2.750	5.875	EY 6-4-6571 <i>High angle yoke</i>
3	1810	2.024-39	2.750	5.188	EY 6.5-4-3261

SSB-38C, SSB-38W, ST-34C, ST-34W, SW-38C, SW-38W

1	1710	2.374-46	3.500	5.156	EY 6-4-5841
1	1710	2.374-46	3.500	5.156	EY 6-4-8341-1X
1	1760	2.374-46	3.500	5.375	EY 6.3-4-1391-1X
1	1760	2.374-46	3.500	5.375	EY 6.3-4-391
1	1810	2.374-46	3.500	5.406	EY 6.5-4-3251
1	1810	2.374-46	3.500	5.406	EY 6.5-4-4271-1X
2	1610	2.024-39	2.750	4.500	EY 5-4-5881
2	1710	2.024-39	2.750	5.000	EY 6-4-5851
2	1710	2.024-39	2.750	5.875	EY 6-4-6571 <i>High angle yoke</i>
2	1710	2.024-39	2.750	5.000	EY 6-4-8331-1X
2	1710	2.024-39	2.750	5.875	EY 6-4-8361-1X <i>High angle yoke</i>
2	1810	2.024-39	2.750	5.188	EY 6.5-4-3261
2	1810	2.024-39	2.750	5.188	EY 6.5-4-4281-1X
3	1610	2.024-39	2.750	4.500	EY 5-4-5881
3	1710	2.024-39	2.750	5.000	EY 6-4-5851
3	1710	2.024-39	2.750	5.875	EY 6-4-6571 <i>High angle yoke</i>
3	1710	2.024-39	2.750	5.000	EY 6-4-8331-1X
3	1710	2.024-39	2.750	5.875	EY 6-4-8361-1X <i>High angle yoke</i>
3	1810	2.024-39	2.750	5.188	EY 6.5-4-3261
3	1810	2.024-39	2.750	5.188	EY 6.5-4-4281-1X

SW-50C, SW-58C

1	1710	2.374-46	3.500	5.156	EY 6-4-5841
1	1710	2.374-46	3.500	5.156	EY 6-4-8341-1X
1	1760	2.374-46	3.500	5.375	EY 6.3-4-1391-1X
1	1760	2.374-46	3.500	5.375	EY 6.3-4-391
1	1810	2.374-46	3.500	5.406	EY 6.5-4-3251
1	1810	2.374-46	3.500	5.406	EY 6.5-4-4271-1X
2	1610	2.024-39	2.750	4.500	EY 5-4-5881
2	1710	2.024-39	2.750	5.000	EY 6-4-5851
2	1710	2.024-39	2.750	5.875	EY 6-4-6571 <i>High angle yoke</i>
2	1810	2.024-39	2.750	5.188	EY 6.5-4-3261
3	1610	2.024-39	2.750	4.500	EY 5-4-5881
3	1710	2.024-39	2.750	5.000	EY 6-4-5851
3	1710	2.024-39	2.750	5.875	EY 6-4-6571 <i>High angle yoke</i>
3	1810	2.024-39	2.750	5.188	EY 6.5-4-3261

SW-65C, SW-65W, SW-80W

1	1760	2.500-10	3.500	5.406	EY 6.3-4-1401-1X
1	1760	2.500-10	3.500	5.406	EY 6.3-4-151
2	1710	2.250-10	3.125	5.250	EY 6-4-2441
3	1710	2.250-10	3.125	5.250	EY 6-4-2441

SW-342C, SW-342W

1	1710	2.374-46	3.500	5.156	EY 6-4-5841
1	1710	2.374-46	3.500	5.156	EY 6-4-8341-1X
1	1760	2.374-46	3.500	5.375	EY 6.3-4-1391-1X
1	1760	2.374-46	3.500	5.375	EY 6.3-4-391
1	1810	2.374-46	3.500	5.406	EY 6.5-4-3251
1	1810	2.374-46	3.500	5.406	EY 6.5-4-4271-1X
2	1610	2.024-39	2.750	4.500	EY 5-4-5881
2	1710	2.024-39	2.750	5.000	EY 6-4-5851
2	1710	2.024-39	2.750	5.875	EY 6-4-6571 <i>High angle yoke</i>
2	1710	2.024-39	2.750	5.000	EY 6-4-8331-1X

Continued on next page

*C/L to End of Hub for EY (End Yoke); Flange Face to End of Hub for CF (Companion Flange)

■ Hub machined for speedometer gear



Important: See Safety Information in General Information Section (J300P-GI)

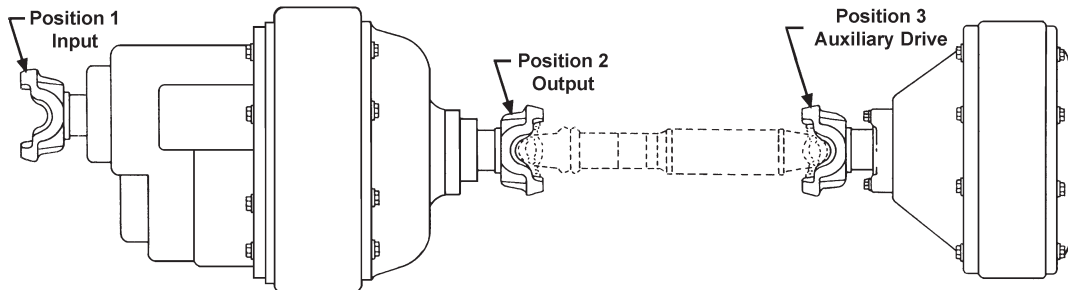

Pos	Series	Spline Data	Hub Dia	* to End of Hub	End Fitting Part Number
-----	--------	-------------	---------	-----------------	-------------------------

SW-342C, SW-342W (Continued)

2	1710	2.024-39	2.750	5.875	EY 6-4-8361-1X <i>High angle yoke</i>
2	1810	2.024-39	2.750	5.188	EY 6.5-4-3261
2	1810	2.024-39	2.750	5.188	EY 6.5-4-4281-1X
3	1610	2.024-39	2.750	4.500	EY 5-4-5881
3	1710	2.024-39	2.750	5.000	EY 6-4-5851
3	1710	2.024-39	2.750	5.875	EY 6-4-6571 <i>High angle yoke</i>
3	1710	2.024-39	2.750	5.000	EY 6-4-8331-1X
3	1710	2.024-39	2.750	5.875	EY 6-4-8361-1X <i>High angle yoke</i>
3	1810	2.024-39	2.750	5.188	EY 6.5-4-3261
3	1810	2.024-39	2.750	5.188	EY 6.5-4-4281-1X

SW-440C

1	1710	2.374-46	3.500	5.156	EY 6-4-5841
1	1710	2.374-46	3.500	5.156	EY 6-4-8341-1X
1	1760	2.374-46	3.500	5.375	EY 6.3-4-1391-1X
1	1760	2.374-46	3.500	5.375	EY 6.3-4-391
1	1810	2.374-46	3.500	5.406	EY 6.5-4-3251
1	1810	2.374-46	3.500	5.406	EY 6.5-4-4271-1X
2	1610	2.024-39	2.750	4.500	EY 5-4-5881
2	1710	2.024-39	2.750	5.000	EY 6-4-5851
2	1710	2.024-39	2.750	5.875	EY 6-4-6571 <i>High angle yoke</i>
3	1610	2.024-39	2.750	4.500	EY 5-4-5881
3	1710	2.024-39	2.750	5.000	EY 6-4-5851
3	1710	2.024-39	2.750	5.875	EY 6-4-6571 <i>High angle yoke</i>

SW-441C

1	1710	2.374-46	3.500	5.156	EY 6-4-5841
1	1710	2.374-46	3.500	5.156	EY 6-4-8341-1X
1	1760	2.374-46	3.500	5.375	EY 6.3-4-1391-1X
1	1760	2.374-46	3.500	5.375	EY 6.3-4-391
1	1810	2.374-46	3.500	5.406	EY 6.5-4-3251
1	1810	2.374-46	3.500	5.406	EY 6.5-4-4271-1X
2	1610	2.024-39	2.750	4.500	EY 5-4-5881
2	1710	2.024-39	2.750	5.000	EY 6-4-5851
2	1710	2.024-39	2.750	5.875	EY 6-4-6571 <i>High angle yoke</i>
2	1810	2.024-39	2.750	5.188	EY 6.5-4-3261
3	1610	2.024-39	2.750	4.500	EY 5-4-5881
3	1710	2.024-39	2.750	5.000	EY 6-4-5851
3	1710	2.024-39	2.750	5.875	EY 6-4-6571 <i>High angle yoke</i>
3	1810	2.024-39	2.750	5.188	EY 6.5-4-3261

SWB-38C

1	SPL170	2.374-46	3.500	5.880	EY 170-4-1211-1
1	SPL170	2.374-46	3.500	5.880	EY 170-4-1221-1X

Pos	Series	Spline Data	Hub Dia	* to End of Hub	End Fitting Part Number
-----	--------	-------------	---------	-----------------	-------------------------

SWB-38C (Continued)

1	SPL250	2.374-46	3.500	6.140	EY 250-4-641-1
1	SPL250	2.374-46	3.500	6.140	EY 250-4-651-1X
1	1710	2.374-46	3.500	5.156	EY 6-4-5841
1	1710	2.374-46	3.500	5.156	EY 6-4-8341-1X
1	1760	2.374-46	3.500	5.375	EY 6.3-4-1391-1X
1	1760	2.374-46	3.500	5.375	EY 6.3-4-391
1	1810	2.374-46	3.500	5.406	EY 6.5-4-3251
1	1810	2.374-46	3.500	5.406	EY 6.5-4-4271-1X
2	SPL170	2.024-39	2.750	5.370	EY 170-4-1251-1 <i>High angle yoke</i>
2	1610	2.024-39	2.750	4.500	EY 5-4-5881
2	1710	2.024-39	2.750	5.000	EY 6-4-5851
2	1710	2.024-39	2.750	5.875	EY 6-4-6571 <i>High angle yoke</i>
2	1710	2.024-39	2.750	5.000	EY 6-4-8331-1X
2	1710	2.024-39	2.750	5.875	EY 6-4-8361-1X <i>High angle yoke</i>
2	1810	2.024-39	2.750	5.188	EY 6.5-4-3261
2	1810	2.024-39	2.750	5.188	EY 6.5-4-4281-1X
3	SPL170	2.024-39	2.750	5.370	EY 170-4-1251-1 <i>High angle yoke</i>
3	SPL170	2.024-39	2.750	5.370	EY 170-4-1261-1X <i>High angle yoke</i>
3	1610	2.024-39	2.750	4.500	EY 5-4-5881
3	1710	2.024-39	2.750	5.000	EY 6-4-5851
3	1710	2.024-39	2.750	5.875	EY 6-4-6571 <i>High angle yoke</i>
3	1710	2.024-39	2.750	5.000	EY 6-4-8331-1X
3	1710	2.024-39	2.750	5.875	EY 6-4-8361-1X <i>High angle yoke</i>
3	1810	2.024-39	2.750	5.188	EY 6.5-4-3261
3	1810	2.024-39	2.750	5.188	EY 6.5-4-4281-1X

SWB-38W, SWB-342C, SWB-342W

1	1710	2.374-46	3.500	5.156	EY 6-4-5841
1	1710	2.374-46	3.500	5.156	EY 6-4-8341-1X
1	1760	2.374-46	3.500	5.375	EY 6.3-4-1391-1X
1	1760	2.374-46	3.500	5.375	EY 6.3-4-391
1	1810	2.374-46	3.500	5.406	EY 6.5-4-3251
1	1810	2.374-46	3.500	5.406	EY 6.5-4-4271-1X
2	1610	2.024-39	2.750	4.500	EY 5-4-5881
2	1710	2.024-39	2.750	5.000	EY 6-4-5851
2	1710	2.024-39	2.750	5.875	EY 6-4-6571 <i>High angle yoke</i>
2	1710	2.024-39	2.750	5.000	EY 6-4-8331-1X
2	1710	2.024-39	2.750	5.875	EY 6-4-8361-1X <i>High angle yoke</i>
2	1810	2.024-39	2.750	5.188	EY 6.5-4-3261
2	1810	2.024-39	2.750	5.188	EY 6.5-4-4281-1X
3	1610	2.024-39	2.750	4.500	EY 5-4-5881

*C/L to End of Hub for EY (End Yoke); Flange Face to End of Hub for CF (Companion Flange)

■ Hub machined for speedometer gear



Pos	Series	Spline Data	Hub Dia	* to End of Hub	End Fitting Part Number
SWB-38W, SWB-342C, SWB-342W (Continued)					
3	1710	2.024-39	2.750	5.000	EY 6-4-5851
3	1710	2.024-39	2.750	5.875	EY 6-4-6571 <i>High angle yoke</i>
3	1710	2.024-39	2.750	5.000	EY 6-4-8331-1X
3	1710	2.024-39	2.750	5.875	EY 6-4-8361-1X <i>High angle yoke</i>
3	1810	2.024-39	2.750	5.188	EY 6.5-4-3261
3	1810	2.024-39	2.750	5.188	EY 6.5-4-4281-1X

SWH-562, SWH-762					
2	1610	2.032-10	2.750	4.500	EY 5-4-4401
2	1710	2.032-10	2.750	5.000	EY 6-4-3791
2	1810	2.031-10	2.750	5.250	EY 6.5-4-2261
3	1610	2.032-10	2.750	4.500	EY 5-4-4401
3	1710	2.032-10	2.750	5.000	EY 6-4-3791
3	1710	2.500-10	3.500	5.156	EY 6-4-4421
3	1710	2.500-10	3.500	5.156	EY 6-4-8351-1X
3	1810	2.500-10	3.500	5.406	EY 6.5-4-2101
3	1810	2.031-10	2.750	5.250	EY 6.5-4-2261

SWP-800W					
1	1710	2.374-46	3.500	5.156	EY 6-4-5841
1	1710	2.374-46	3.500	5.156	EY 6-4-8341-1X
1	1760	2.374-46	3.500	5.375	EY 6.3-4-1391-1X
1	1760	2.374-46	3.500	5.375	EY 6.3-4-391
1	1810	2.374-46	3.500	5.406	EY 6.5-4-3251
1	1810	2.374-46	3.500	5.406	EY 6.5-4-4271-1X
2	1610	2.024-39	2.750	4.500	EY 5-4-5881
2	1710	2.024-39	2.750	5.000	EY 6-4-5851
2	1710	2.024-39	2.750	5.875	EY 6-4-6571 <i>High angle yoke</i>
2	1810	2.024-39	2.750	5.188	EY 6.5-4-3261
3	1610	2.024-39	2.750	4.500	EY 5-4-5881
3	1710	2.024-39	2.750	5.000	EY 6-4-5851
3	1710	2.024-39	2.750	5.875	EY 6-4-6571 <i>High angle yoke</i>
3	1810	2.024-39	2.750	5.188	EY 6.5-4-3261

SWP-801W					
1	1760	2.500-10	3.500	5.406	EY 6.3-4-1401-1X
1	1760	2.500-10	3.500	5.406	EY 6.3-4-151
2	1710	2.250-10	3.125	5.250	EY 6-4-2441
3	1710	2.250-10	3.125	5.250	EY 6-4-2441

SWS-56					
2	1610	2.032-10	2.750	4.500	EY 5-4-4401
2	1710	2.032-10	2.750	5.000	EY 6-4-3791
2	1810	2.031-10	2.750	5.250	EY 6.5-4-2261
3	1610	2.032-10	2.750	4.500	EY 5-4-4401
3	1710	2.032-10	2.750	5.000	EY 6-4-3791
3	1710	2.500-10	3.500	5.156	EY 6-4-4421
3	1710	2.500-10	3.500	5.156	EY 6-4-8351-1X
3	1810	2.500-10	3.500	5.406	EY 6.5-4-2101
3	1810	2.031-10	2.750	5.250	EY 6.5-4-2261

SWS-57, SWS-68, SSW-56, SSW-57, SSW-68					
2	1610	2.032-10	2.750	4.500	EY 5-4-4401
2	1710	2.032-10	2.750	5.000	EY 6-4-3791
2	1810	2.031-10	2.750	5.250	EY 6.5-4-2261
3	1610	2.032-10	2.750	4.500	EY 5-4-4401
3	1710	2.032-10	2.750	5.000	EY 6-4-3791
3	1710	2.500-10	3.500	5.156	EY 6-4-4421

Pos	Series	Spline Data	Hub Dia	* to End of Hub	End Fitting Part Number
SWS-57, SWS-68, SSW-56, SSW-57, SSW-68 (Continued)					
3	1710	2.500-10	3.500	5.156	EY 6-4-8351-1X
3	1810	2.500-10	3.500	5.406	EY 6.5-4-2101
3	1810	2.031-10	2.750	5.250	EY 6.5-4-2261
SSW-69					
1	1710	2.500-10	3.500	5.156	EY 6-4-4421
1	1710	2.500-10	3.500	5.156	EY 6-4-8351-1X
1	1810	2.500-10	3.500	5.406	EY 6.5-4-2101
2	1710	2.250-10	3.125	5.250	EY 6-4-2441
2	1810	2.250-10	3.125	5.375	EY 6.5-4-2141
2	1810	2.250-10	3.125	5.375	EY 6.5-4-4221-1X

SSW-76, SSW-562, SSW-762					
2	1610	2.032-10	2.750	4.500	EY 5-4-4401
2	1710	2.032-10	2.750	5.000	EY 6-4-3791
2	1810	2.031-10	2.750	5.250	EY 6.5-4-2261
3	1610	2.032-10	2.750	4.500	EY 5-4-4401
3	1710	2.032-10	2.750	5.000	EY 6-4-3791
3	1710	2.500-10	3.500	5.156	EY 6-4-4421
3	1710	2.500-10	3.500	5.156	EY 6-4-8351-1X
3	1810	2.500-10	3.500	5.406	EY 6.5-4-2101
3	1810	2.031-10	2.750	5.250	EY 6.5-4-2261

*C/L to End of Hub for EY (End Yoke); Flange Face to End of Hub for CF (Companion Flange)

■ Hub machined for speedometer gear



Important: See Safety Information in General Information Section (J300P-GI)

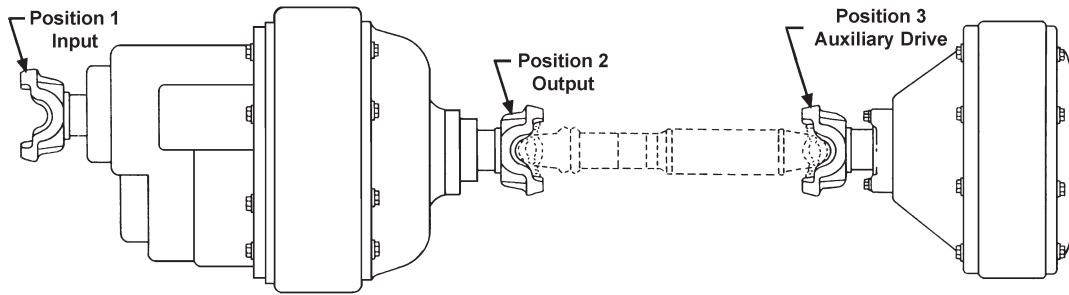

Pos	Series	Spline Data	Hub Dia	* to End of Hub	End Fitting Part Number
-----	--------	-------------	---------	-----------------	-------------------------

OSHKOSH

TAK-4

2	SPL170	1.998-38	3.000	4.898	EY 170-4-1961-1X
3	SPL170	1.998-38	3.000	4.898	EY 170-4-1961-1X

MERITOR/ROCKWELL

MT-14X

1	SPL350	2.390-46	3.252	5.551	EY 350-4-61-1X
2	SPL250	2.024-39	3.000	5.300	EY 250-4-311-1 <i>Counterbore at hub end.</i>

MT-160

1	SPL350	2.390-46	3.252	5.551	EY 350-4-61-1X
---	--------	----------	-------	-------	----------------

RT--140**

1	SPL140	2.024-39	3.000	5.680	EY 140-4-211-1
1	SPL170	1.774-34	2.500	5.031	EY 170-4-1751-1X
1	SPL170	2.024-39	3.000	5.090	EY 170-4-641-1
1	SPL170	2.024-39	3.000	5.090	EY 170-4-681-1X
1	SPL250	2.024-39	3.000	5.300	EY 250-4-311-1 <i>Counterbore at hub end.</i>
1	SPL250	2.024-39	3.000	5.300	EY 250-4-321-1X <i>Counterbore at hub end.</i>
1	1610	2.024-39	3.000	4.875	EY 5-4-6421
1	1610	2.024-39	3.000	4.875	EY 5-4-6421-1
1	1610	2.024-39	3.000	4.875	EY 5-4-6431-1X
1	1610	2.024-39	3.000	4.875	EY 5-4-6431X
1	1710	2.024-39	3.000	6.250	EY 6-4-6371 <i>High angle yoke</i>
1	1710	2.024-39	3.000	6.250	EY 6-4-6381X <i>High angle yoke</i>
1	1710	2.024-39	3.000	5.156	EY 6-4-7621-1
1	1760	2.024-39	3.000	5.188	EY 6.3-4-531
1	1760	2.024-39	3.000	5.188	EY 6.3-4-531-1
1	1760	2.024-39	3.000	5.188	EY 6.3-4-541-1X
1	1760	2.024-39	3.000	5.188	EY 6.3-4-541X
1	1810	2.390-46	3.250	5.062	EY 5004767
1	1810	2.024-39	3.000	5.190	EY 6.5-4-3371
1	1810	2.024-39	3.000	5.190	EY 6.5-4-3371-1
1	1810	2.024-39	3.000	5.190	EY 6.5-4-3381-1X
1	1810	2.024-39	3.000	5.190	EY 6.5-4-3381X
2	SPL170	1.774-34	2.500	5.031	EY 170-4-621-1
2	SPL170	1.774-34	2.500	6.440	EY 170-4-631-1 <i>High angle yoke</i>
2	1610	1.774-34	2.500	6.062	EY 5-4-6251 <i>High angle yoke</i>
2	1610	1.774-34	2.500	5.438	EY 5-4-6261
2	1610	1.774-34	2.500	5.438	EY 5-4-6261-1
2	1710	1.774-34	2.500	5.969	EY 6-4-6321 <i>High angle yoke</i>
2	1710	1.774-34	2.500	5.969	EY 6-4-6321-1 <i>High angle yoke</i>

Pos	Series	Spline Data	Hub Dia	* to End of Hub	End Fitting Part Number
-----	--------	-------------	---------	-----------------	-------------------------

RT--140 (Continued)**

2	1710	1.774-34	2.500	4.875	EY 6-4-6331
2	1710	1.774-34	2.500	4.875	EY 6-4-6331-1
3	SPL140	2.024-39	3.000	5.680	EY 140-4-211-1
3	SPL140	2.024-39	3.000	5.680	EY 140-4-231-1X
3	SPL170	2.024-39	3.000	5.090	EY 170-4-641-1
3	SPL170	2.024-39	3.000	5.090	EY 170-4-651-1X
3	SPL170	2.024-39	3.000	6.391	EY 170-4-661-1 <i>High angle yoke</i>
3	SPL170	2.024-39	3.000	6.391	EY 170-4-671-1X <i>High angle yoke</i>
3	SPL170	2.024-39	3.000	5.090	EY 170-4-681-1X
3	SPL90	2.024-39	3.000	4.625	EY 90-4-311-1
3	SPL90	2.024-39	3.000	4.625	EY 90-4-321-1X
3	1480	2.024-39	3.000	4.281	EY 3-4-8861
3	1480	2.024-39	3.000	4.281	EY 3-4-8871X
3	1550	2.024-39	3.000	5.000	EY 4-4-5261-1
3	1550	2.024-39	3.000	5.000	EY 4-4-6731-1X
3	1610	2.024-39	3.000	6.219	EY 5-4-6241 <i>High angle yoke</i>
3	1610	2.024-39	3.000	6.219	EY 5-4-6241-1 <i>High angle yoke</i>
3	1610	2.024-39	3.000	5.531	EY 5-4-6271
3	1610	2.024-39	3.000	5.531	EY 5-4-6281X
3	1610	2.024-39	3.000	6.219	EY 5-4-6291-1X <i>High angle yoke</i>
3	1610	2.024-39	3.000	6.219	EY 5-4-6291X <i>High angle yoke</i>
3	1610	2.024-39	3.000	4.875	EY 5-4-6421-1
3	1610	2.024-39	3.000	4.875	EY 5-4-6441-1X
3	1710	2.024-39	3.000	6.250	EY 6-4-6371 <i>High angle yoke</i>
3	1710	2.024-39	3.000	6.250	EY 6-4-6371-1 <i>High angle yoke</i>
3	1710	2.024-39	3.000	6.250	EY 6-4-6391-1X <i>High angle yoke</i>
3	1710	2.024-39	3.000	6.250	EY 6-4-6391X <i>High angle yoke</i>
3	1710	2.024-39	3.000	5.156	EY 6-4-6401
3	1710	2.024-39	3.000	5.156	EY 6-4-6421X
3	1710	2.024-39	3.000	5.156	EY 6-4-7621-1
3	1710	2.024-39	3.000	5.156	EY 6-4-7641-1X
3	1710	2.024-39	3.000	5.156	EY 6-4-8601-1X
3	1760	2.024-39	3.000	5.188	EY 6.3-4-1141-1X
3	1760	2.024-39	3.000	5.188	EY 6.3-4-531
3	1760	2.024-39	3.000	5.188	EY 6.3-4-531-1
3	1810	2.024-39	3.000	5.190	EY 6.5-4-3371
3	1810	2.024-39	3.000	5.190	EY 6.5-4-3371-1
3	1810	2.024-39	3.000	5.190	EY 6.5-4-3381-1X
3	1810	2.024-39	3.000	5.190	EY 6.5-4-3381X

*C/L to End of Hub for EY (End Yoke); Flange Face to End of Hub for CF (Companion Flange)

■ Hub machined for speedometer gear



Pos	Series	Spline Data	Hub Dia	* to End of Hub	End Fitting Part Number
RT-**-145					
1	SPL140	2.390-46	3.250	5.660	EY 140-4-03557-1X
1	SPL140	2.390-46	3.250	5.660	EY 140-4-301-1
1	SPL140	2.390-46	3.250	5.660	EY 140-4-311-1X
1	SPL140	2.390-46	3.250	5.660	EY 5003557
1	SPL170	2.390-46	3.250	5.100	EY 170-4-03558-1X
1	SPL170	2.390-46	3.250	6.438	EY 170-4-03559-1X
1	SPL170	2.390-46	3.250	5.100	EY 170-4-711-1
1	SPL170	2.390-46	3.250	5.100	EY 170-4-721-1X
1	SPL170	2.390-46	3.250	6.438	EY 170-4-731-1
1	SPL170	2.390-46	3.250	6.438	EY 170-4-741-1X <i>High angle yoke</i>
1	SPL170	2.390-46	3.250	5.100	EY 5003558
1	SPL250	2.390-46	3.250	5.312	EY 250-4-03560-1X
1	SPL250	2.390-46	3.250	5.312	EY 250-4-1041-1X
1	SPL250	2.390-46	3.250	5.312	EY 250-4-341-1
1	SPL250	2.390-46	3.250	5.312	EY 250-4-351-1X
1	SPL90	2.390-46	3.250	4.641	EY 90-4-331-1
1	SPL90	2.390-46	3.250	4.641	EY 90-4-341-1X
1	1610	2.024-39	3.000	4.875	EY 5-4-6431-1X
1	1610	2.390-46	3.250	4.938	EY 5-4-7331-1
1	1610	2.390-46	3.250	4.938	EY 5-4-7341-1X
1	1710	2.390-46	3.250	5.391	EY 5003553
1	1710	2.390-46	3.250	5.391	EY 6-4-03553-1X
1	1710	2.024-39	3.000	6.250	EY 6-4-6381X <i>High angle yoke</i>
1	1710	2.024-39	3.000	6.250	EY 6-4-6391X <i>High angle yoke</i>
1	1710	2.024-39	3.000	5.156	EY 6-4-6411X
1	1710	2.390-46	3.250	5.391	EY 6-4-7161
1	1710	2.390-46	3.250	5.391	EY 6-4-7161-1
1	1710	2.390-46	3.250	5.391	EY 6-4-7181-1X
1	1710	2.390-46	3.250	5.391	EY 6-4-7181X
1	1710	2.024-39	3.000	5.156	EY 6-4-7641-1X
1	1710	2.390-46	3.250	6.500	EY 6-4-7761 <i>High angle yoke</i>
1	1710	2.390-46	3.250	6.500	EY 6-4-7761-1 <i>High angle yoke</i>
1	1710	2.390-46	3.250	6.500	EY 6-4-7771-1X <i>High angle yoke</i>
1	1710	2.390-46	3.250	6.500	EY 6-4-7771X <i>High angle yoke</i>
1	1710	2.024-39	3.000	5.156	EY 6-4-8601-1X
1	1760	2.390-46	3.250	5.062	EY 5003555
1	1760	2.390-46	3.250	5.062	EY 6.3-4-03555-1X
1	1760	2.390-46	3.250	5.062	EY 6.3-4-1031
1	1760	2.390-46	3.250	5.062	EY 6.3-4-1031-1
1	1760	2.390-46	3.250	5.062	EY 6.3-4-1041-1X
1	1760	2.390-46	3.250	5.062	EY 6.3-4-1041X
1	1760	2.024-39	3.000	5.188	EY 6.3-4-541-1X
1	1760	2.024-39	3.000	5.188	EY 6.3-4-541X
1	1810	2.390-46	3.250	5.156	EY 5003556
1	1810	2.390-46	3.250	5.156	EY 6.5-4-03556-1X
1	1810	2.024-39	3.000	5.190	EY 6.5-4-3371
1	1810	2.024-39	3.000	5.190	EY 6.5-4-3371-1
1	1810	2.024-39	3.000	5.190	EY 6.5-4-3381-1X
1	1810	2.024-39	3.000	5.190	EY 6.5-4-3381X
1	1810	2.390-46	3.250	5.156	EY 6.5-4-3721
1	1810	2.390-46	3.250	5.156	EY 6.5-4-3721-1
1	1810	2.390-46	3.250	5.156	EY 6.5-4-3731-1X

Pos	Series	Spline Data	Hub Dia	* to End of Hub	End Fitting Part Number
RT-**-145 (Continued)					
1	1810	2.390-46	3.250	5.156	EY 6.5-4-3731X
1	1810	2.390-46	3.250	5.156	EY 6.5-4-5111X
2	SPL140	2.024-39	3.000	5.680	EY 140-4-211-1
2	SPL170	2.024-39	3.000	5.090	EY 170-4-641-1
2	SPL170	2.024-39	3.000	6.391	EY 170-4-661-1 <i>High angle yoke</i>
2	SPL250	2.024-39	3.000	5.300	EY 250-4-311-1 <i>Counterbore at hub end.</i>
2	1610	2.024-39	3.000	6.219	EY 5-4-6241 <i>High angle yoke</i>
2	1610	2.024-39	3.000	6.219	EY 5-4-6241-1 <i>High angle yoke</i>
2	1610	2.024-39	3.000	5.531	EY 5-4-6271
2	1610	2.024-39	3.000	5.531	EY 5-4-6281X
2	1710	2.024-39	3.000	6.250	EY 6-4-6371 <i>High angle yoke</i>
2	1710	2.024-39	3.000	6.250	EY 6-4-6371-1 <i>High angle yoke</i>
2	1710	2.024-39	3.000	5.156	EY 6-4-6401
2	1710	2.024-39	3.000	5.156	EY 6-4-7621-1
2	1810	2.024-39	3.000	5.190	EY 6.5-4-3371
2	1810	2.024-39	3.000	5.190	EY 6.5-4-3371-1
3	SPL140	2.024-39	3.000	5.680	EY 140-4-211-1
3	SPL140	2.024-39	3.000	5.680	EY 140-4-231-1X
3	SPL170	2.024-39	3.000	5.090	EY 170-4-641-1
3	SPL170	2.024-39	3.000	5.090	EY 170-4-651-1X
3	SPL170	2.024-39	3.000	6.391	EY 170-4-661-1 <i>High angle yoke</i>
3	SPL170	2.024-39	3.000	6.391	EY 170-4-671-1X <i>High angle yoke</i>
3	SPL90	2.024-39	3.000	4.625	EY 90-4-311-1
3	SPL90	2.024-39	3.000	4.625	EY 90-4-321-1X
3	1480	2.024-39	3.000	4.281	EY 3-4-8861
3	1480	2.024-39	3.000	4.281	EY 3-4-8871X
3	1550	2.024-39	3.000	5.000	EY 4-4-5261-1
3	1550	2.024-39	3.000	5.000	EY 4-4-6731-1X
3	1610	2.024-39	3.000	6.219	EY 5-4-6241 <i>High angle yoke</i>
3	1610	2.024-39	3.000	6.219	EY 5-4-6241-1 <i>High angle yoke</i>
3	1610	2.024-39	3.000	5.531	EY 5-4-6271
3	1610	2.024-39	3.000	5.531	EY 5-4-6281X
3	1610	2.024-39	3.000	6.219	EY 5-4-6291-1X <i>High angle yoke</i>
3	1610	2.024-39	3.000	6.219	EY 5-4-6291X <i>High angle yoke</i>
3	1610	2.024-39	3.000	4.875	EY 5-4-6421-1
3	1610	2.024-39	3.000	4.875	EY 5-4-6441-1X
3	1710	2.024-39	3.000	6.250	EY 6-4-6371 <i>High angle yoke</i>
3	1710	2.024-39	3.000	6.250	EY 6-4-6371-1 <i>High angle yoke</i>
3	1710	2.024-39	3.000	6.250	EY 6-4-6391-1X <i>High angle yoke</i>
3	1710	2.024-39	3.000	6.250	EY 6-4-6391X <i>High angle yoke</i>
3	1710	2.024-39	3.000	5.156	EY 6-4-6401
3	1710	2.024-39	3.000	5.156	EY 6-4-6421X
3	1710	2.024-39	3.000	5.156	EY 6-4-7621-1
3	1710	2.024-39	3.000	5.156	EY 6-4-7641-1X

Continued on next page

*C/L to End of Hub for EY (End Yoke); Flange Face to End of Hub for CF (Companion Flange)

■ Hub machined for speedometer gear



Important: See Safety Information in General Information Section (J300P-GI)

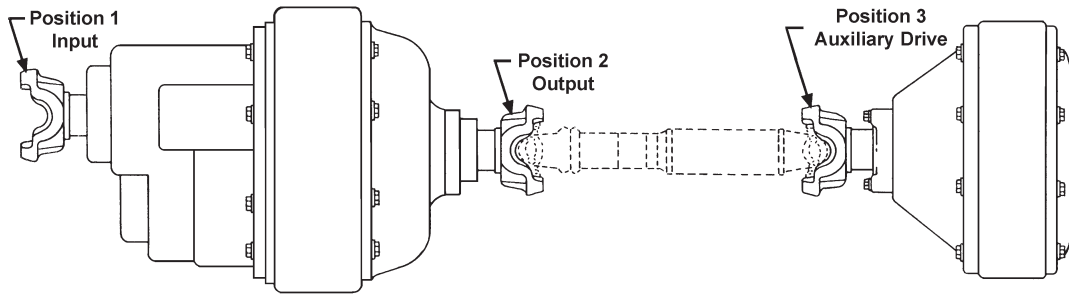

Pos	Series	Spline Data	Hub Dia	* to End of Hub	End Fitting Part Number
-----	--------	-------------	---------	-----------------	-------------------------

RT--145 (Continued)**

3	1710	2.024-39	3.000	6.250	EY 6-4-8571-1X <i>High angle yoke</i>
3	1710	2.024-39	3.000	6.250	EY 6-4-8571X <i>High angle yoke</i>
3	1760	2.024-39	3.000	5.188	EY 6.3-4-1141-1X
3	1760	2.024-39	3.000	5.188	EY 6.3-4-531
3	1760	2.024-39	3.000	5.188	EY 6.3-4-531-1
3	1760	2.024-39	3.000	5.188	EY 6.3-4-541-1X
3	1760	2.024-39	3.000	5.188	EY 6.3-4-541X
3	1810	2.024-39	3.000	5.190	EY 6.5-4-3371
3	1810	2.024-39	3.000	5.190	EY 6.5-4-3371-1
3	1810	2.024-39	3.000	5.190	EY 6.5-4-3381-1X
3	1810	2.024-39	3.000	5.190	EY 6.5-4-3381X

RT--150**

1	1710	2.390-46	3.250	6.500	EY 6-4-7771-1X <i>High angle yoke</i>
3	1710	2.390-46	3.250	6.500	EY 6-4-7771-1X <i>High angle yoke</i>

RT--157**

1	SPL250	2.374-46	3.250	5.610	EY 250-4-771-1
1	SPL250	2.374-46	3.250	5.610	EY 250-4-781-1X
1	1710	2.374-46	3.250	5.688	EY 6-4-5451
1	1710	2.374-46	3.250	5.688	EY 6-4-5451-1
1	1710	2.374-46	3.250	5.688	EY 6-4-5461-1X
1	1710	2.374-46	3.250	5.688	EY 6-4-5461X
1	1760	2.374-46	3.250	5.438	EY 6.3-4-101
1	1760	2.374-46	3.250	5.438	EY 6.3-4-101-1
1	1760	2.374-46	3.250	5.438	EY 6.3-4-211-1X
1	1760	2.374-46	3.250	5.438	EY 6.3-4-211X
1	1810	2.374-46	3.250	5.438	EY 6.5-4-2701
1	1810	2.374-46	3.250	5.438	EY 6.5-4-2701-1
1	1810	2.374-46	3.250	5.438	EY 6.5-4-2711-1X
1	1810	2.374-46	3.250	5.438	EY 6.5-4-2711X
2	SPL140	2.024-39	2.750	5.250	EY 140-4-1421-1
2	1610	2.024-39	2.750	5.125	EY 5-4-5421
2	1610	2.024-39	2.750	5.938	EY 5-4-5441 <i>High angle yoke</i>
2	1710	2.024-39	2.750	6.500	EY 6-4-5501
2	1710	2.024-39	2.750	6.500	EY 6-4-5501-1 <i>High angle yoke</i>
2	1710	2.024-39	2.750	5.250	EY 6-4-5521
2	1710	2.024-39	2.750	5.250	EY 6-4-5521-1
2	1810	2.024-39	2.750	5.531	EY 6.5-4-2781
2	1810	2.024-39	2.750	5.625	EY 6.5-4-2781-1
3	SPL140	2.024-39	2.750	5.250	EY 140-4-1421-1
3	SPL140	2.024-39	2.750	5.250	EY 140-4-1431-1X
3	1610	2.024-39	2.750	5.125	EY 5-4-5421
3	1610	2.024-39	2.750	5.938	EY 5-4-5441 <i>High angle yoke</i>

Pos	Series	Spline Data	Hub Dia	* to End of Hub	End Fitting Part Number
-----	--------	-------------	---------	-----------------	-------------------------

RT--157 (Continued)**

3	1610	2.024-39	2.750	5.125	EY 5-4-6951X
3	1610	2.024-39	2.750	5.938	EY 5-4-6961X <i>High angle yoke</i>
3	1710	2.024-39	2.750	6.500	EY 6-4-5501
3	1710	2.024-39	2.750	6.500	EY 6-4-5501-1 <i>High angle yoke</i>
3	1710	2.024-39	2.750	5.250	EY 6-4-5521
3	1710	2.024-39	2.750	5.250	EY 6-4-5521-1
3	1710	2.024-39	2.750	6.500	EY 6-4-6871-1X <i>High angle yoke</i>
3	1710	2.024-39	2.750	6.500	EY 6-4-6871X
3	1710	2.024-39	2.750	5.250	EY 6-4-6951-1X
3	1710	2.024-39	2.750	5.250	EY 6-4-6951X
3	1810	2.024-39	2.750	5.531	EY 6.5-4-2781
3	1810	2.024-39	2.750	5.625	EY 6.5-4-2781-1
3	1810	2.024-39	2.750	5.625	EY 6.5-4-3571-1X
3	1810	2.024-39	2.750	5.531	EY 6.5-4-3571X

RT--160**

1	SPL140	2.390-46	3.250	5.660	EY 140-4-03557-1X
1	SPL140	2.390-46	3.250	5.660	EY 140-4-301-1
1	SPL140	2.390-46	3.250	5.660	EY 140-4-311-1X
1	SPL140	2.390-46	3.250	5.660	EY 5003557
1	SPL170	2.390-46	3.250	5.100	EY 170-4-03558-1X
1	SPL170	2.390-46	3.250	6.438	EY 170-4-03559-1X
1	SPL170	2.390-46	3.250	5.100	EY 170-4-711-1
1	SPL170	2.390-46	3.250	5.100	EY 170-4-721-1X
1	SPL170	2.390-46	3.250	6.438	EY 170-4-731-1
1	SPL170	2.390-46	3.250	6.438	EY 170-4-741-1X <i>High angle yoke</i>
1	SPL170	2.390-46	3.250	5.100	EY 5003558
1	SPL250	2.390-46	3.250	5.312	EY 250-4-03560-1X
1	SPL250	2.390-46	3.250	5.312	EY 250-4-1041-1X
1	SPL250	2.390-46	3.250	5.312	EY 250-4-341-1
1	SPL250	2.390-46	3.250	5.312	EY 250-4-351-1X
1	SPL90	2.390-46	3.250	4.641	EY 90-4-331-1
1	SPL90	2.390-46	3.250	4.641	EY 90-4-341-1X
1	1610	2.390-46	3.250	4.938	EY 5-4-7331-1
1	1610	2.390-46	3.250	4.938	EY 5-4-7341-1X
1	1710	2.390-46	3.250	5.391	EY 5003553
1	1710	2.390-46	3.250	5.391	EY 6-4-03553-1X
1	1710	2.390-46	3.250	5.391	EY 6-4-7161
1	1710	2.390-46	3.250	5.391	EY 6-4-7161-1
1	1710	2.390-46	3.250	5.391	EY 6-4-7181-1X
1	1710	2.390-46	3.250	5.391	EY 6-4-7181X
1	1710	2.390-46	3.250	6.500	EY 6-4-7761 <i>High angle yoke</i>
1	1710	2.390-46	3.250	6.500	EY 6-4-7761-1 <i>High angle yoke</i>

*C/L to End of Hub for EY (End Yoke); Flange Face to End of Hub for CF (Companion Flange)

■ Hub machined for speedometer gear



Pos	Series	Spline Data	Hub Dia	* to End of Hub	End Fitting Part Number
RT-**-160 (Continued)					
1	1710	2.390-46	3.250	6.500	EY 6-4-7771-1X <i>High angle yoke</i>
1	1710	2.390-46	3.250	6.500	EY 6-4-7771X <i>High angle yoke</i>
1	1760	2.390-46	3.250	5.062	EY 5003555
1	1760	2.390-46	3.250	5.062	EY 6.3-4-03555-1X
1	1760	2.390-46	3.250	5.062	EY 6.3-4-1031
1	1760	2.390-46	3.250	5.062	EY 6.3-4-1031-1
1	1760	2.390-46	3.250	5.062	EY 6.3-4-1041-1X
1	1760	2.390-46	3.250	5.062	EY 6.3-4-1041X
1	1810	2.390-46	3.250	5.156	EY 5003556
1	1810	2.390-46	3.250	5.062	EY 5004767
1	1810	2.390-46	3.250	5.156	EY 6.5-4-03556-1X
1	1810	2.390-46	3.250	5.156	EY 6.5-4-3721
1	1810	2.390-46	3.250	5.156	EY 6.5-4-3721-1
1	1810	2.390-46	3.250	5.156	EY 6.5-4-3731-1X
1	1810	2.390-46	3.250	5.156	EY 6.5-4-3731X
1	1810	2.390-46	3.250	5.156	EY 6.5-4-5111X
2	SPL170	2.024-39	2.625	5.270	EY 170-4-211-1 <i>High angle yoke</i>
2	SPL170	2.024-39	3.000	5.090	EY 170-4-641-1
2	SPL170	2.024-39	3.000	6.391	EY 170-4-661-1 <i>High angle yoke</i>
2	SPL250	2.024-39	3.000	5.300	EY 250-4-311-1 <i>25 degree yoke; Counterbore at hub end.</i>
2	1610	2.024-39	3.000	6.219	EY 5-4-6241 <i>High angle yoke</i>
2	1610	2.024-39	3.000	6.219	EY 5-4-6241-1 <i>High angle yoke</i>
2	1610	2.024-39	3.000	5.531	EY 5-4-6271
2	1710	2.024-39	3.000	6.250	EY 6-4-6371 <i>High angle yoke</i>
2	1710	2.024-39	3.000	6.250	EY 6-4-6371-1 <i>High angle yoke</i>
2	1710	2.024-39	3.000	5.156	EY 6-4-6401
2	1710	2.024-39	3.000	5.156	EY 6-4-6401-1
2	1710	2.024-39	3.000	5.156	EY 6-4-7621-1
2	1810	2.024-39	3.000	5.190	EY 6.5-4-3371
2	1810	2.024-39	3.000	5.190	EY 6.5-4-3371-1
3	SPL140	2.390-46	3.250	5.660	EY 140-4-301-1
3	SPL140	2.390-46	3.250	5.660	EY 140-4-311-1X
3	SPL170	2.390-46	3.250	5.100	EY 170-4-711-1
3	SPL170	2.390-46	3.250	5.100	EY 170-4-721-1X
3	SPL170	2.390-46	3.250	6.438	EY 170-4-731-1
3	SPL170	2.390-46	3.250	6.438	EY 170-4-741-1X <i>High angle yoke</i>
3	SPL250	2.390-46	3.250	5.312	EY 250-4-341-1
3	SPL250	2.390-46	3.250	5.312	EY 250-4-351-1X <i>25 degree yoke</i>
3	SPL90	2.390-46	3.250	4.641	EY 90-4-331-1
3	SPL90	2.390-46	3.250	4.641	EY 90-4-341-1X
3	1610	2.390-46	3.250	4.938	EY 5-4-7331-1
3	1610	2.390-46	3.250	4.938	EY 5-4-7341-1X
3	1710	2.390-46	3.250	5.391	EY 6-4-7161
3	1710	2.390-46	3.250	5.391	EY 6-4-7161-1
3	1710	2.390-46	3.250	5.391	EY 6-4-7181-1X
3	1710	2.390-46	3.250	5.391	EY 6-4-7181X
3	1710	2.390-46	3.250	6.500	EY 6-4-7761 <i>High angle yoke</i>
3	1710	2.390-46	3.250	6.500	EY 6-4-7761-1 <i>High angle yoke</i>

Pos	Series	Spline Data	Hub Dia	* to End of Hub	End Fitting Part Number
RT-**-160 (Continued)					
3	1710	2.390-46	3.250	6.500	EY 6-4-7771-1X <i>High angle yoke</i>
3	1710	2.390-46	3.250	6.500	EY 6-4-7771X <i>High angle yoke</i>
3	1760	2.390-46	3.250	5.062	EY 6.3-4-1031
3	1760	2.390-46	3.250	5.062	EY 6.3-4-1031-1
3	1760	2.390-46	3.250	5.062	EY 6.3-4-1041-1X
3	1760	2.390-46	3.250	5.062	EY 6.3-4-1041X
3	1810	2.390-46	3.250	5.156	EY 6.5-4-3721
3	1810	2.390-46	3.250	5.156	EY 6.5-4-3721-1
3	1810	2.390-46	3.250	5.156	EY 6.5-4-3731-1X
3	1810	2.390-46	3.250	5.156	EY 6.5-4-3731X
RT-**-180, RT-**-185					
1	SPL140	2.374-46	3.250	6.210	EY 140-4-271-1
1	SPL170	2.374-46	3.250	5.760	EY 170-4-571-1
1	SPL170	2.374-46	3.250	5.760	EY 170-4-581-1X
1	SPL250	2.374-46	3.250	5.870	EY 250-4-281-1
1	SPL250	2.374-46	3.250	5.870	EY 250-4-291-1X
1	1710	2.374-46	3.250	5.938	EY 6-4-5931
1	1710	2.374-46	3.250	5.938	EY 6-4-5931-1
1	1710	2.374-46	3.250	5.938	EY 6-4-5961-1X
1	1710	2.374-46	3.250	5.938	EY 6-4-5961X
1	1760	2.374-46	3.250	5.625	EY 6.3-4-291
1	1760	2.374-46	3.250	5.625	EY 6.3-4-291-1
1	1760	2.374-46	3.250	5.625	EY 6.3-4-301-1X
1	1760	2.374-46	3.250	5.625	EY 6.3-4-301X
1	1810	2.374-46	3.250	5.688	EY 6.5-4-3201
1	1810	2.374-46	3.250	5.688	EY 6.5-4-3201-1
1	1810	2.374-46	3.250	5.688	EY 6.5-4-3221-1X
1	1810	2.374-46	3.250	5.688	EY 6.5-4-3221X
2	SPL170	2.024-39	3.000	5.090	EY 170-4-641-1
2	SPL170	2.024-39	3.000	6.391	EY 170-4-661-1 <i>High angle yoke</i>
2	1610	2.024-39	3.000	6.219	EY 5-4-6241 <i>High angle yoke</i>
2	1610	2.024-39	3.000	6.219	EY 5-4-6241-1 <i>High angle yoke</i>
2	1610	2.024-39	3.000	5.531	EY 5-4-6271
2	1710	2.024-39	3.000	6.250	EY 6-4-6371 <i>High angle yoke</i>
2	1710	2.024-39	3.000	6.250	EY 6-4-6371-1 <i>High angle yoke</i>
2	1710	2.024-39	3.000	5.156	EY 6-4-6401
2	1710	2.024-39	3.000	5.156	EY 6-4-6401-1
2	1710	2.024-39	3.000	5.156	EY 6-4-7621-1
2	1610	2.024-39	3.000	5.531	EY 5-4-6271
2	1710	2.024-39	3.000	6.250	EY 6-4-6371 <i>High angle yoke</i>
2	1710	2.024-39	3.000	6.250	EY 6-4-6371-1 <i>High angle yoke</i>
2	1710	2.024-39	3.000	5.156	EY 6-4-6401
2	1710	2.024-39	3.000	5.156	EY 6-4-6401-1
2	1710	2.024-39	3.000	5.156	EY 6-4-7621-1
3	SPL140	2.374-46	3.250	6.210	EY 140-4-271-1
3	SPL140	2.374-46	3.250	6.210	EY 140-4-291-1X
3	SPL170	2.374-46	3.250	5.760	EY 170-4-571-1
3	SPL170	2.374-46	3.250	5.760	EY 170-4-591-1X
3	SPL170	2.374-46	3.250	7.250	EY 170-4-601-1 <i>High angle yoke</i>
3	SPL170	2.374-46	3.250	7.250	EY 170-4-611-1X <i>High angle yoke</i>
3	SPL250	2.374-46	3.250	5.870	EY 250-4-281-1
3	SPL250	2.374-46	3.250	5.870	EY 250-4-301-1X
3	SPL90	2.374-46	3.250	5.188	EY 90-4-351-1
3	SPL90	2.374-46	3.250	5.188	EY 90-4-361-1X
3	1610	2.374-46	3.250	4.547	EY 5-4-7351-1
3	1610	2.374-46	3.250	4.547	EY 5-4-7361-1X

Continued on next page

*C/L to End of Hub for EY (End Yoke); Flange Face to End of Hub for CF (Companion Flange)

■ Hub machined for speedometer gear



Important: See Safety Information in General Information Section (J300P-GI)

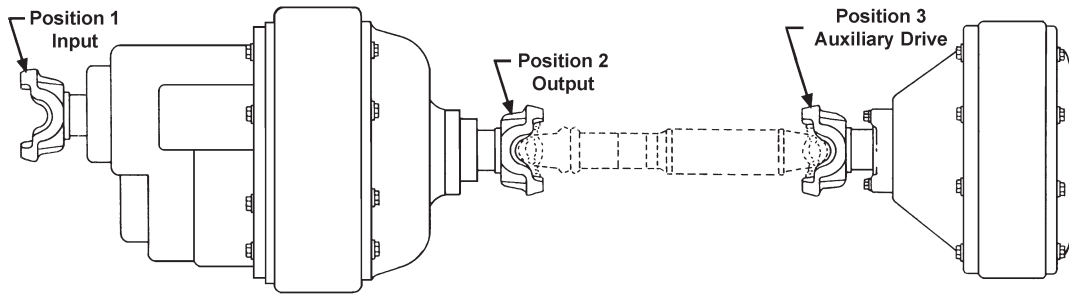

Pos	Series	Spline Data	Hub Dia	* to End of Hub	End Fitting Part Number
RT**-180, RT**-185					
3	1710	2.374-46	3.250	5.938	EY 6-4-5931
3	1710	2.374-46	3.250	5.938	EY 6-4-5931-1
3	1710	2.374-46	3.250	5.938	EY 6-4-6961-1X
3	1710	2.374-46	3.250	5.938	EY 6-4-6961X
3	1710	2.374-46	3.250	6.938	EY 6-4-7831 <i>High angle yoke</i>
3	1710	2.374-46	3.250	6.938	EY 6-4-7831-1 <i>High angle yoke</i>
3	1710	2.374-46	3.250	6.938	EY 6-4-7851-1X <i>High angle yoke</i>
3	1710	2.374-46	3.250	6.938	EY 6-4-7851X <i>High angle yoke</i>
3	1760	2.374-46	3.250	5.625	EY 6.3-4-291
3	1760	2.374-46	3.250	5.625	EY 6.3-4-291-1
3	1760	2.374-46	3.250	5.625	EY 6.3-4-861-1X
3	1760	2.374-46	3.250	5.625	EY 6.3-4-861X
3	1810	2.374-46	3.250	5.688	EY 6.5-4-3201
3	1810	2.374-46	3.250	5.688	EY 6.5-4-3201-1
3	1810	2.374-46	3.250	5.688	EY 6.5-4-3581-1X
3	1810	2.374-46	3.250	5.688	EY 6.5-4-3581X

Pos	Series	Spline Data	Hub Dia	* to End of Hub	End Fitting Part Number
RT**-380					
1	SPL140	2.374-46	3.250	6.210	EY 140-4-271-1
1	SPL170	2.374-46	3.250	5.760	EY 170-4-571-1
1	SPL170	2.374-46	3.250	5.760	EY 170-4-581-1X
1	SPL170	2.390-46	3.250	6.438	EY 170-4-741-1X <i>High angle yoke</i>
1	SPL250	2.374-46	3.250	5.870	EY 250-4-281-1
1	SPL250	2.374-46	3.250	5.870	EY 250-4-291-1X
1	1710	2.374-46	3.250	5.938	EY 6-4-5931
1	1710	2.374-46	3.250	5.938	EY 6-4-5931-1
1	1710	2.374-46	3.250	5.938	EY 6-4-5961-1X
1	1710	2.374-46	3.250	5.938	EY 6-4-5961X
1	1710	2.024-39	3.000	6.250	EY 6-4-6371-1 <i>High angle yoke</i>
1	1760	2.374-46	3.250	5.625	EY 6.3-4-291
1	1760	2.374-46	3.250	5.625	EY 6.3-4-291-1
1	1760	2.374-46	3.250	5.625	EY 6.3-4-301-1X
1	1760	2.374-46	3.250	5.625	EY 6.3-4-301X
1	1810	2.374-46	3.250	5.688	EY 6.5-4-3201
1	1810	2.374-46	3.250	5.688	EY 6.5-4-3201-1
1	1810	2.374-46	3.250	5.688	EY 6.5-4-3221-1X
1	1810	2.374-46	3.250	5.688	EY 6.5-4-3221X
2	SPL140	2.024-39	3.000	5.680	EY 140-4-211-1
2	SPL170	2.024-39	3.000	5.090	EY 170-4-641-1
2	SPL170	2.024-39	3.000	6.391	EY 170-4-661-1 <i>High angle yoke</i>
2	1610	2.024-39	3.000	6.219	EY 5-4-6241 <i>High angle yoke</i>
2	1610	2.024-39	3.000	6.219	EY 5-4-6241-1 <i>High angle yoke</i>

Pos	Series	Spline Data	Hub Dia	* to End of Hub	End Fitting Part Number
RT**-380 (Continued)					
2	1610	2.024-39	3.000	5.531	EY 5-4-6271
2	1710	2.024-39	3.000	6.250	EY 6-4-6371 <i>High angle yoke</i>
2	1710	2.024-39	3.000	6.250	EY 6-4-6371-1 <i>High angle yoke</i>
2	1710	2.024-39	3.000	5.156	EY 6-4-6401
2	1710	2.024-39	3.000	5.156	EY 6-4-6401-1
2	1710	2.024-39	3.000	5.156	EY 6-4-7621-1
3	SPL140	2.024-39	3.000	5.680	EY 140-4-211-1
3	SPL140	2.024-39	3.000	5.680	EY 140-4-241-1X
3	SPL170	2.024-39	3.000	5.090	EY 170-4-641-1
3	SPL170	2.024-39	3.000	6.391	EY 170-4-661-1 <i>High angle yoke</i>
3	SPL170	2.024-39	3.000	6.391	EY 170-4-691-1X <i>High angle yoke</i>
3	SPL170	2.024-39	3.000	5.090	EY 170-4-701-1X
3	SPL170	2.390-46	3.250	6.438	EY 170-4-741-1X <i>High angle yoke</i>
3	SPL250	2.024-39	3.000	5.300	EY 250-4-311-1 <i>Counterbore at hub end.</i>
3	1710	2.024-39	3.000	6.250	EY 6-4-6371 <i>High angle yoke</i>
3	1710	2.024-39	3.000	6.250	EY 6-4-6371-1 <i>High angle yoke</i>
3	1710	2.024-39	3.000	6.250	EY 6-4-6391-1X <i>High angle yoke</i>
3	1710	2.024-39	3.000	6.250	EY 6-4-6391X <i>High angle yoke</i>
3	1710	2.024-39	3.000	5.156	EY 6-4-7621-1
3	1710	2.374-46	3.250	6.938	EY 6-4-7831 <i>High angle yoke</i>
3	1710	2.374-46	3.250	6.938	EY 6-4-7831-1 <i>High angle yoke</i>
3	1710	2.374-46	3.250	6.938	EY 6-4-7851-1X <i>High angle yoke</i>
3	1710	2.374-46	3.250	6.938	EY 6-4-7851X <i>High angle yoke</i>
3	1710	2.024-39	3.000	5.156	EY 6-4-8601-1X
3	1760	2.024-39	3.000	5.188	EY 6.3-4-1341-1X
3	1760	2.024-39	3.000	5.188	EY 6.3-4-531-1
3	1810	2.024-39	3.000	5.190	EY 6.5-4-3371-1
3	1810	2.024-39	3.000	5.190	EY 6.5-4-4191-1X

Pos	Series	Spline Data	Hub Dia	* to End of Hub	End Fitting Part Number
RT-140					
1	SPL140	2.024-39	3.000	5.680	EY 140-4-211-1
1	SPL170	2.024-39	3.000	5.090	EY 170-4-641-1
1	SPL170	2.024-39	3.000	5.090	EY 170-4-681-1X
1	SPL250	2.024-39	3.000	5.300	EY 250-4-311-1 <i>Counterbore at hub end.</i>
1	SPL250	2.024-39	3.000	5.300	EY 250-4-321-1X <i>Counterbore at hub end.</i>

*C/L to End of Hub for EY (End Yoke); Flange Face to End of Hub for CF (Companion Flange)

■ Hub machined for speedometer gear



Pos	Series	Spline Data	Hub Dia	* to End of Hub	End Fitting Part Number
RT-140 (Continued)					
1	1610	2.024-39	3.000	4.875	EY 5-4-6421
1	1610	2.024-39	3.000	4.875	EY 5-4-6421-1
1	1610	2.024-39	3.000	4.875	EY 5-4-6431-1X
1	1610	2.024-39	3.000	4.875	EY 5-4-6431X
1	1710	2.024-39	3.000	6.250	EY 6-4-6371 <i>High angle yoke</i>
1	1710	2.024-39	3.000	6.250	EY 6-4-6371-1 <i>High angle yoke</i>
1	1710	2.024-39	3.000	6.250	EY 6-4-6381X <i>High angle yoke</i>
1	1710	2.024-39	3.000	5.156	EY 6-4-7621-1
1	1710	2.024-39	3.000	5.156	EY 6-4-7631-1X
1	1760	2.024-39	3.000	5.188	EY 6.3-4-531
1	1760	2.024-39	3.000	5.188	EY 6.3-4-531-1
1	1760	2.024-39	3.000	5.188	EY 6.3-4-541-1X
1	1760	2.024-39	3.000	5.188	EY 6.3-4-541X
1	1810	2.024-39	3.000	5.190	EY 6.5-4-3371
1	1810	2.024-39	3.000	5.190	EY 6.5-4-3371-1
1	1810	2.024-39	3.000	5.190	EY 6.5-4-3381-1X
1	1810	2.024-39	3.000	5.190	EY 6.5-4-3381X
2	SPL170	1.774-34	2.500	5.031	EY 170-4-1751-1X
SDHD					
2	1410	1.375-10	2.125	3.500	EY 3-4-3941-1
3	1410	1.375-10	2.125	3.500	EY 3-4-3941-1
SFD					
1	1650/1710	2.250-10	3.000	3.750	CF 6-1-1421 <i>.250 deep counterbore at hub end</i>
1	1810	2.250-10	3.000	3.750	CF 6.5-1-211 <i>.250 deep counterbore at hub end</i>
1	1610	2.250-10	3.000	5.625	EY 5-4-6891X
1	1710	2.250-10	3.000	6.062	EY 6-4-4411X
1	1810	2.250-10	3.000	5.844	EY 6.5-4-2551X
2	1610	2.250-10	3.000	5.625	EY 5-4-6891X
2	1710	2.250-10	3.000	6.062	EY 6-4-4411X
2	1810	2.250-10	3.000	5.844	EY 6.5-4-2551X
3	1610	2.250-10	3.000	5.625	EY 5-4-6891X
3	1710	2.250-10	3.000	6.062	EY 6-4-4411X
3	1810	2.250-10	3.000	5.844	EY 6.5-4-2551X
SFDD					
1	1710	2.250-10	3.000	6.062	EY 6-4-1991-1
1	1710	2.250-10	3.000	6.062	EY 6-4-4411-1X
1	1710	2.374-46	3.250	5.688	EY 6-4-5461-1X
1	1710	2.374-46	3.250	5.688	EY 6-4-5461X
1	1760	2.374-46	3.250	5.438	EY 6.3-4-211X
1	1810	2.374-46	3.250	5.438	EY 6.5-4-2701
1	1810	2.374-46	3.250	5.438	EY 6.5-4-2701-1
1	1810	2.374-46	3.250	5.438	EY 6.5-4-2711-1X
1	1810	2.374-46	3.250	5.438	EY 6.5-4-2711X
2	1610	1.960-10	2.750	5.125	EY 5-4-5281X
2	1610	1.962-10	2.750	5.938	EY 5-4-5321X
2	1610	2.024-39	2.750	5.125	EY 5-4-6951X
2	1610	2.024-39	2.750	5.938	EY 5-4-6961X <i>High angle yoke</i>
2	1710	1.960-10	2.750	5.250	EY 6-4-4361X
2	1710	1.960-10	2.750	6.500	EY 6-4-4481X <i>High angle yoke</i>
2	1710	2.024-39	2.750	6.500	EY 6-4-6871X
2	1710	2.024-39	2.750	4.812	EY 6-4-6941X
2	1710	2.024-39	2.750	5.250	EY 6-4-6951X
2	1810	2.024-39	2.750	5.531	EY 6.5-4-3571X

Pos	Series	Spline Data	Hub Dia	* to End of Hub	End Fitting Part Number
SFDD (Continued)					
3	1610	1.960-10	2.750	5.125	EY 5-4-5281X
3	1610	1.962-10	2.750	5.938	EY 5-4-5321X
3	1610	2.024-39	2.750	5.125	EY 5-4-6951X
3	1610	2.024-39	2.750	5.938	EY 5-4-6961X <i>High angle yoke</i>
3	1710	1.960-10	2.750	5.250	EY 6-4-4361X
3	1710	1.960-10	2.750	6.500	EY 6-4-4481X <i>High angle yoke</i>
3	1710	2.024-39	2.750	6.500	EY 6-4-6871X
3	1710	2.024-39	2.750	4.812	EY 6-4-6941X
3	1710	2.024-39	2.750	5.250	EY 6-4-6951X
3	1810	2.024-39	2.750	5.531	EY 6.5-4-3571X
SFDD-4600, SFDD-4640, SFDD-4700, SFDD-4740					
1	1650/1710	2.250-10	3.000	3.750	CF 6-1-1421 <i>.250 deep counterbore at hub end</i>
1	1810	2.250-10	3.000	3.750	CF 6.5-1-211 <i>.250 deep counterbore at hub end</i>
1	1610	2.250-10	3.000	5.625	EY 5-4-6891X
1	1710	2.250-10	3.000	6.062	EY 6-4-1991
1	1710	2.250-10	3.000	6.062	EY 6-4-1991-1
1	1710	2.250-10	3.000	6.062	EY 6-4-4411-1X
1	1710	2.250-10	3.000	6.062	EY 6-4-4411X
1	1810	2.250-10	3.000	5.844	EY 6.5-4-2551X
2	1610	2.250-10	3.000	5.625	EY 5-4-6891X
2	1710	2.250-10	3.000	6.062	EY 6-4-4411X
2	1810	2.250-10	3.000	5.844	EY 6.5-4-2551X
3	1610	2.250-10	3.000	5.625	EY 5-4-6891X
3	1710	2.250-10	3.000	6.062	EY 6-4-4411X
3	1810	2.250-10	3.000	5.844	EY 6.5-4-2551X
SFHD					
2	1410	1.500-10	2.250	3.875	EY 3-4-2241-1
3	1410	1.500-10	2.250	3.875	EY 3-4-2241-1
SHD					
1	SPL250	2.374-46	3.250	5.610	EY 250-4-771-1
1	SPL250	2.374-46	3.250	5.610	EY 250-4-781-1X
1	1710	2.374-46	3.250	5.688	EY 6-4-5451
1	1710	2.374-46	3.250	5.688	EY 6-4-5451-1
1	1710	2.374-46	3.250	5.688	EY 6-4-5461-1X
1	1710	2.374-46	3.250	5.688	EY 6-4-5461X
1	1760	2.374-46	3.250	5.438	EY 6.3-4-101
1	1760	2.374-46	3.250	5.438	EY 6.3-4-101-1
1	1760	2.374-46	3.250	5.438	EY 6.3-4-211-1X
1	1760	2.374-46	3.250	5.438	EY 6.3-4-211X
1	1810	2.374-46	3.250	5.438	EY 6.5-4-2701
1	1810	2.374-46	3.250	5.438	EY 6.5-4-2701-1
1	1810	2.374-46	3.250	5.438	EY 6.5-4-2711-1X
1	1810	2.374-46	3.250	5.438	EY 6.5-4-2711X
2	SPL140	2.024-39	2.750	5.250	EY 140-4-1421-1
2	1610	1.960-10	2.750	5.125	EY 5-4-5281X
2	1610	1.962-10	2.750	5.938	EY 5-4-5321X
2	1610	2.024-39	2.750	5.125	EY 5-4-5421
2	1610	2.024-39	2.750	5.938	EY 5-4-5441 <i>High angle yoke</i>
2	1610	2.024-39	2.750	5.125	EY 5-4-6951X
2	1610	2.024-39	2.750	5.938	EY 5-4-6961X <i>High angle yoke</i>
2	1710	1.960-10	2.750	5.250	EY 6-4-4361X

Continued on next page

*C/L to End of Hub for EY (End Yoke); Flange Face to End of Hub for CF (Companion Flange)

■ Hub machined for speedometer gear



Important: See Safety Information in General Information Section (J300P-GI)

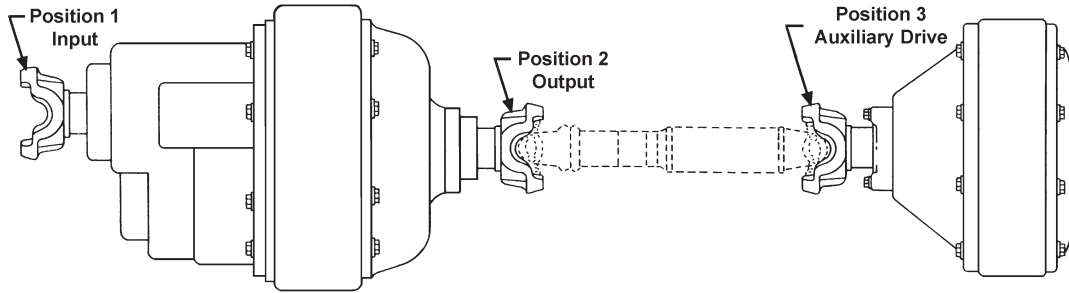

Pos	Series	Spline Data	Hub Dia	* to End of Hub	End Fitting Part Number
-----	--------	-------------	---------	-----------------	-------------------------

SHD (Continued)

2	1710	1.960-10	2.750	6.500	EY 6-4-4481X <i>High angle yoke</i>
2	1710	2.024-39	2.750	6.500	EY 6-4-5501-1 <i>High angle yoke</i>
2	1710	2.024-39	2.750	5.250	EY 6-4-5521
2	1710	2.024-39	2.750	5.250	EY 6-4-5521-1
2	1710	2.024-39	2.750	6.500	EY 6-4-6871-1X <i>High angle yoke</i>
2	1710	2.024-39	2.750	6.500	EY 6-4-6871X
2	1710	2.024-39	2.750	4.812	EY 6-4-6941X
2	1710	2.024-39	2.750	5.250	EY 6-4-6951-1X
2	1710	2.024-39	2.750	5.250	EY 6-4-6951X
2	171070	2.024-39	2.750	6.500	EY 6-4-5501
2	1810	2.024-39	2.750	5.531	EY 6.5-4-2781
2	1810	2.024-39	2.750	5.625	EY 6.5-4-2781-1
2	1810	2.024-39	2.750	5.625	EY 6.5-4-3571-1X
2	1810	2.024-39	2.750	5.531	EY 6.5-4-3571X
3	SPL140	2.024-39	2.750	5.250	EY 140-4-1421-1
3	SPL140	2.024-39	2.750	5.250	EY 140-4-1431-1X
3	1610	1.960-10	2.750	5.125	EY 5-4-5281X
3	1610	1.962-10	2.750	5.938	EY 5-4-5321X
3	1610	2.024-39	2.750	5.125	EY 5-4-5421
3	1610	2.024-39	2.750	5.938	EY 5-4-5441 <i>High angle yoke</i>
3	1610	2.024-39	2.750	5.125	EY 5-4-6951X
3	1610	2.024-39	2.750	5.938	EY 5-4-6961X <i>High angle yoke</i>
3	1710	1.960-10	2.750	5.250	EY 6-4-4361X
3	1710	1.960-10	2.750	6.500	EY 6-4-4481X <i>High angle yoke</i>
3	1710	2.024-39	2.750	5.250	EY 6-4-5521
3	1710	2.024-39	2.750	5.250	EY 6-4-5521-1
3	1710	2.024-39	2.750	6.500	EY 6-4-6871-1X <i>High angle yoke</i>
3	1710	2.024-39	2.750	6.500	EY 6-4-6871X
3	1710	2.024-39	2.750	4.812	EY 6-4-6941X
3	1710	2.024-39	2.750	5.250	EY 6-4-6951-1X
3	1710	2.024-39	2.750	5.250	EY 6-4-6951X
3	171070	2.024-39	2.750	6.500	EY 6-4-5501
3	171070	2.024-39	2.750	6.500	EY 6-4-5501-1 <i>High angle yoke</i>
3	1810	2.024-39	2.750	5.531	EY 6.5-4-2781
3	1810	2.024-39	2.750	5.625	EY 6.5-4-2781-1
3	1810	2.024-39	2.750	5.625	EY 6.5-4-3571-1X
3	1810	2.024-39	2.750	5.531	EY 6.5-4-3571X

SHDD

1	SPL250	2.374-46	3.250	5.610	EY 250-4-771-1
1	SPL250	2.374-46	3.250	5.610	EY 250-4-781-1X
1	1410	1.875-10	2.750	4.406	EY 3-4-6671-1X

Pos	Series	Spline Data	Hub Dia	* to End of Hub	End Fitting Part Number
-----	--------	-------------	---------	-----------------	-------------------------

SHDD (Continued)

1	1710	2.374-46	3.250	5.688	EY 6-4-5451
1	1710	2.374-46	3.250	5.688	EY 6-4-5451-1
1	1710	2.374-46	3.250	5.688	EY 6-4-5461-1X
1	1710	2.374-46	3.250	5.688	EY 6-4-5461X
1	1760	2.374-46	3.250	5.438	EY 6.3-4-101
1	1760	2.374-46	3.250	5.438	EY 6.3-4-101-1
1	1760	2.374-46	3.250	5.438	EY 6.3-4-211-1X
1	1760	2.374-46	3.250	5.438	EY 6.3-4-211X
1	1810	2.374-46	3.250	5.438	EY 6.5-4-2701
1	1810	2.374-46	3.250	5.438	EY 6.5-4-2701-1
1	1810	2.374-46	3.250	5.438	EY 6.5-4-2711-1X
1	1810	2.374-46	3.250	5.438	EY 6.5-4-2711X
2	SPL140	2.024-39	2.750	5.250	EY 140-4-1421-1
2	1410	1.625-10	2.375	4.188	EY 3-4-5921-1X
2	1610	1.960-10	2.750	5.125	EY 5-4-5281X
2	1610	1.962-10	2.750	5.938	EY 5-4-5321X
2	1610	2.024-39	2.750	5.125	EY 5-4-6951X
2	1610	2.024-39	2.750	5.938	EY 5-4-6961X <i>High angle yoke</i>
2	1710	1.960-10	2.750	5.250	EY 6-4-4361X
2	1710	1.960-10	2.750	6.500	EY 6-4-4481X <i>High angle yoke</i>
2	1710	2.024-39	2.750	6.500	EY 6-4-6871X
2	1710	2.024-39	2.750	4.812	EY 6-4-6941X
2	1710	2.024-39	2.750	5.250	EY 6-4-6951X
2	1810	2.024-39	2.750	5.531	EY 6.5-4-3571X
3	SPL140	2.024-39	2.750	5.250	EY 140-4-1421-1
3	SPL140	2.024-39	2.750	5.250	EY 140-4-1431-1X
3	1410	1.625-10	2.375	4.188	EY 3-4-5921-1X
3	1610	1.960-10	2.750	5.125	EY 5-4-5281X
3	1610	1.962-10	2.750	5.938	EY 5-4-5321X
3	1610	2.024-39	2.750	5.125	EY 5-4-6951X
3	1610	2.024-39	2.750	5.938	EY 5-4-6961X <i>High angle yoke</i>
3	1710	1.960-10	2.750	5.250	EY 6-4-4361X
3	1710	1.960-10	2.750	6.500	EY 6-4-4481X <i>High angle yoke</i>
3	1710	2.024-39	2.750	6.500	EY 6-4-6871X
3	1710	2.024-39	2.750	6.500	EY 6-4-6871X <i>High angle yoke</i>
3	1710	2.024-39	2.750	4.812	EY 6-4-6941X
3	1710	2.024-39	2.750	5.250	EY 6-4-6951X
3	1710	2.024-39	2.750	5.250	EY 6-4-6951X
3	1810	2.024-39	2.750	5.531	EY 6.5-4-3571X

SHHD

1	1550	1.875-10	2.750	4.406	EY 4-4-1941
1	1610	1.875-10	2.750	5.000	EY 5-4-2501
2	1350	1.625-10	2.375	3.969	EY 3-4-9001X
2	1480	1.625-10	2.375	4.312	EY 3-4-3771
2	1610	1.625-10	2.375	4.125	EY 5-4-2401
3	1350	1.625-10	2.375	3.969	EY 3-4-9001X
3	1480	1.625-10	2.375	4.312	EY 3-4-3771
3	1610	1.625-10	2.375	4.125	EY 5-4-2401

*C/L to End of Hub for EY (End Yoke); Flange Face to End of Hub for CF (Companion Flange)

■ Hub machined for speedometer gear



Pos	Series	Spline Data	Hub Dia	* to End of Hub	End Fitting Part Number
SJHD					
1	1410	1.875-10	2.750	4.406	EY 3-4-6671-1X
1	1550	1.875-10	2.750	4.406	EY 4-4-1941
1	1610	1.875-10	2.750	5.000	EY 5-4-2501
2	1350	1.625-10	2.375	3.969	EY 3-4-9001X
2	1410	1.625-10	2.375	4.188	EY 3-4-5921-1X
2	1480	1.625-10	2.375	4.312	EY 3-4-3771
2	1610	1.625-10	2.375	4.125	EY 5-4-2401
3	1350	1.625-10	2.375	3.969	EY 3-4-9001X
3	1410	1.625-10	2.375	4.188	EY 3-4-5921-1X
3	1480	1.625-10	2.375	4.312	EY 3-4-3771
3	1610	1.625-10	2.375	4.125	EY 5-4-2401

Pos	Series	Spline Data	Hub Dia	* to End of Hub	End Fitting Part Number
SL-100					
1	1610	2.024-39	3.000	5.531	EY 5-4-6281X
1	1610	2.024-39	3.000	4.875	EY 5-4-6431-1X
1	1610	2.024-39	3.000	4.875	EY 5-4-6431X
1	1710	2.024-39	3.000	6.250	EY 6-4-6381X <i>High angle yoke</i>
1	1710	2.024-39	3.000	5.156	EY 6-4-6401
1	1710	2.024-39	3.000	5.156	EY 6-4-6401-1
1	1710	2.024-39	3.000	5.156	EY 6-4-6411X
1	1710	2.024-39	3.000	5.156	EY 6-4-7621-1
1	1710	2.024-39	3.000	5.156	EY 6-4-7631-1X
1	1760	2.024-39	3.000	5.188	EY 6.3-4-531
1	1760	2.024-39	3.000	5.188	EY 6.3-4-531-1
1	1760	2.024-39	3.000	5.188	EY 6.3-4-541-1X
1	1760	2.024-39	3.000	5.188	EY 6.3-4-541X
1	1810	2.024-39	3.000	5.190	EY 6.5-4-3371
1	1810	2.024-39	3.000	5.190	EY 6.5-4-3371-1
1	1810	2.024-39	3.000	5.190	EY 6.5-4-3381-1X
1	1810	2.024-39	3.000	5.190	EY 6.5-4-3381X
1	1810	2.024-39	3.000	5.750	EY 6.5-4-3881-1X
2	1610	2.250-10	3.500	3.625	CF 5-1-6331
2	1610	1.774-34	2.500	6.062	EY 5-4-6251 <i>High angle yoke</i>
2	1610	1.774-34	2.500	5.438	EY 5-4-6261
2	1610	1.998-38	2.750	4.125	EY 5-4-6321
2	1710	1.774-34	2.500	5.969	EY 6-4-6321 <i>High angle yoke</i>
2	1710	1.774-34	2.500	4.875	EY 6-4-6331
2	1760	2.024-39	3.000	5.188	EY 6.3-4-1141-1X
3	1610	2.024-39	3.000	5.531	EY 5-4-6281X
3	1610	2.024-39	3.000	6.219	EY 5-4-6291X <i>High angle yoke</i>
3	1610	2.024-39	3.000	4.875	EY 5-4-6431-1X
3	1610	2.024-39	3.000	4.875	EY 5-4-6431X
3	1610	2.024-39	3.000	4.875	EY 5-4-6441-1X
3	1710	2.024-39	3.000	6.250	EY 6-4-6391X <i>High angle yoke</i>
3	1710	2.024-39	3.000	5.156	EY 6-4-6401
3	1710	2.024-39	3.000	5.156	EY 6-4-6421-1X
3	1710	2.024-39	3.000	5.156	EY 6-4-6421X
3	1710	2.024-39	3.000	5.156	EY 6-4-7621-1
3	1710	2.024-39	3.000	5.156	EY 6-4-7631-1X
3	1710	2.024-39	3.000	5.156	EY 6-4-7641-1X
3	1710	2.024-39	3.000	5.156	EY 6-4-8601-1X
3	1760	2.024-39	3.000	5.188	EY 6.3-4-1141-1X
3	1760	2.024-39	3.000	5.188	EY 6.3-4-531
3	1760	2.024-39	3.000	5.188	EY 6.3-4-531-1

Pos	Series	Spline Data	Hub Dia	* to End of Hub	End Fitting Part Number
SL-100P					
1	1610	2.024-39	3.000	5.531	EY 5-4-6281X
1	1610	2.024-39	3.000	4.875	EY 5-4-6431-1X
1	1610	2.024-39	3.000	4.875	EY 5-4-6431X
1	1710	2.024-39	3.000	6.250	EY 6-4-6381X <i>High angle yoke</i>
1	1710	2.024-39	3.000	5.156	EY 6-4-6401
1	1710	2.024-39	3.000	5.156	EY 6-4-6401-1
1	1710	2.024-39	3.000	5.156	EY 6-4-6411X
1	1710	2.024-39	3.000	5.156	EY 6-4-7631-1X
1	1760	2.024-39	3.000	5.188	EY 6.3-4-531
1	1760	2.024-39	3.000	5.188	EY 6.3-4-531-1
1	1760	2.024-39	3.000	5.188	EY 6.3-4-541-1X
1	1810	2.024-39	3.000	5.190	EY 6.5-4-3371
1	1810	2.024-39	3.000	5.190	EY 6.5-4-3371-1
1	1810	2.024-39	3.000	5.190	EY 6.5-4-3381-1X
1	1810	2.024-39	3.000	5.190	EY 6.5-4-3381X
1	1810	2.024-39	3.000	5.188	EY 6.5-4-3851-1X
2	1610	2.250-10	3.500	3.625	CF 5-1-6331
2	1610	1.774-34	2.500	6.062	EY 5-4-6251 <i>High angle yoke</i>
2	1610	1.774-34	2.500	5.438	EY 5-4-6261
2	1610	1.998-38	2.750	4.125	EY 5-4-6321
2	1710	1.774-34	2.500	5.969	EY 6-4-6321 <i>High angle yoke</i>
2	1710	1.774-34	2.500	4.875	EY 6-4-6331
3	1610	2.024-39	3.000	5.531	EY 5-4-6281X
3	1610	2.024-39	3.000	6.219	EY 5-4-6291X <i>High angle yoke</i>
3	1610	2.024-39	3.000	4.875	EY 5-4-6431-1X
3	1610	2.024-39	3.000	4.875	EY 5-4-6431X
3	1610	2.024-39	3.000	4.875	EY 5-4-6441-1X
3	1710	2.024-39	3.000	6.250	EY 6-4-6391X <i>High angle yoke</i>
3	1710	2.024-39	3.000	5.156	EY 6-4-6421-1X
3	1710	2.024-39	3.000	5.156	EY 6-4-6421X
3	1710	2.024-39	3.000	5.156	EY 6-4-7621-1
3	1710	2.024-39	3.000	5.156	EY 6-4-7631-1X
3	1710	2.024-39	3.000	5.156	EY 6-4-7641-1X
3	1710	2.024-39	3.000	5.156	EY 6-4-8601-1X
3	1760	2.024-39	3.000	5.188	EY 6.3-4-1141-1X
3	1760	2.024-39	3.000	5.188	EY 6.3-4-541X

Pos	Series	Spline Data	Hub Dia	* to End of Hub	End Fitting Part Number
SLD, SLDD					
1	1480	1.875-10	2.750	4.406	EY 3-4-6671-1X
1	1550	1.875-10	2.750	4.406	EY 4-4-1941
1	1610	1.875-10	2.750	5.000	EY 5-4-2501
2	1480	1.875-10	2.750	4.406	EY 3-4-6671-1X
2	1550	1.875-10	2.750	4.406	EY 4-4-1941
2	1610	1.875-10	2.750	5.000	EY 5-4-2501
3	1480	1.875-10	2.750	4.406	EY 3-4-6671-1X
3	1550	1.875-10	2.750	4.406	EY 4-4-1941
3	1610	1.875-10	2.750	5.000	EY 5-4-2501

Pos	Series	Spline Data	Hub Dia	* to End of Hub	End Fitting Part Number
SLHD					
1	1610	2.000-10	2.938	5.188	EY 5-4-5131X
1	1710	2.000-10	2.938	5.188	EY 6-4-3241
1	1760	2.000-10	2.938	5.375	EY 6.3-4-181X

Pos	Series	Spline Data	Hub Dia	* to End of Hub	End Fitting Part Number
SLHP					
1	1760	2.024-39	3.000	5.188	EY 6.3-4-191X

*C/L to End of Hub for EY (End Yoke); Flange Face to End of Hub for CF (Companion Flange)

■ Hub machined for speedometer gear



Important: See Safety Information in General Information Section (J300P-GI)

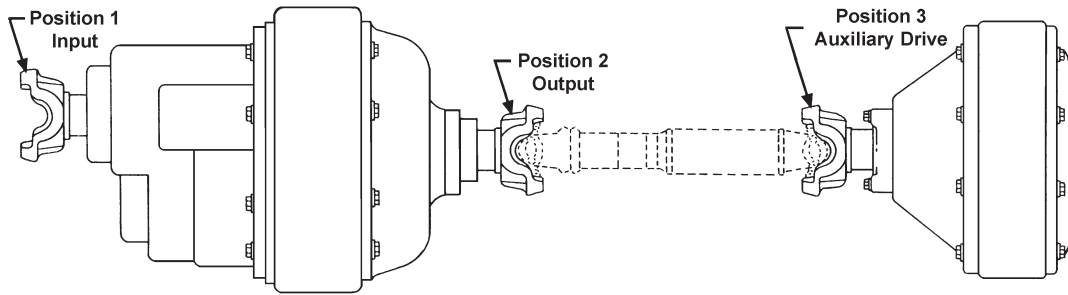

Pos	Series	Spline Data	Hub Dia	* to End of Hub	End Fitting Part Number
-----	--------	-------------	---------	-----------------	-------------------------

SPRC-1357					
1	1610	2.024-39	3.000	5.531	EY 5-4-6281X
1	1610	2.024-39	3.000	4.875	EY 5-4-6431-1X
1	1610	2.024-39	3.000	4.875	EY 5-4-6431X
1	1710	2.024-39	3.000	6.250	EY 6-4-6381X <i>High angle yoke</i>
1	1710	2.024-39	3.000	5.156	EY 6-4-6411X
1	1710	2.024-39	3.000	5.156	EY 6-4-7631-1X
1	1760	2.024-39	3.000	5.188	EY 6.3-4-541-1X
1	1760	2.024-39	3.000	5.188	EY 6.3-4-541X
1	1810	2.024-39	3.000	5.190	EY 6.5-4-3381-1X
1	1810	2.024-39	3.000	5.190	EY 6.5-4-3381X
2	1610	2.250-10	3.500	3.625	CF 5-1-6331
2	1610	1.774-34	2.500	6.062	EY 5-4-6251 <i>High angle yoke</i>
2	1610	1.774-34	2.500	5.438	EY 5-4-6261
2	1710	1.774-34	2.500	5.969	EY 6-4-6321 <i>High angle yoke</i>
2	1710	1.774-34	2.500	4.875	EY 6-4-6331
3	1610	2.024-39	3.000	5.531	EY 5-4-6281X
3	1610	2.024-39	3.000	6.219	EY 5-4-6291X <i>High angle yoke</i>
3	1610	2.024-39	3.000	4.875	EY 5-4-6431-1X
3	1610	2.024-39	3.000	4.875	EY 5-4-6431X
3	1610	2.024-39	3.000	4.875	EY 5-4-6441-1X
3	1710	2.024-39	3.000	6.250	EY 6-4-6391X <i>High angle yoke</i>
3	1710	2.024-39	3.000	5.156	EY 6-4-6421-1X
3	1710	2.024-39	3.000	5.156	EY 6-4-6421X
3	1710	2.024-39	3.000	5.156	EY 6-4-7631-1X
3	1710	2.024-39	3.000	5.156	EY 6-4-7641-1X
3	1710	2.024-39	3.000	5.156	EY 6-4-8601-1X
3	1760	2.024-39	3.000	5.188	EY 6.3-4-541X

SPR450					
2	1710	1.960-10	2.750	5.250	EY 6-4-3221
2	1710	1.960-10	2.750	5.250	EY 6-4-3221-1
3	1710	1.960-10	2.750	5.250	EY 6-4-3221
3	1710	1.960-10	2.750	5.250	EY 6-4-3221-1

SQ-100					
1	SPL140	2.024-39	3.000	5.680	EY 140-4-211-1
1	SPL170	1.774-34	2.500	5.031	EY 170-4-1751-1X
1	SPL170	2.024-39	3.000	5.090	EY 170-4-641-1
1	SPL170	2.024-39	3.000	5.090	EY 170-4-681-1X
1	SPL250	2.024-39	3.000	5.300	EY 250-4-311-1 <i>Counterbore at hub end.</i>
1	SPL250	2.024-39	3.000	5.300	EY 250-4-321-1X <i>Counterbore at hub end.</i>
1	1610	2.024-39	3.000	4.875	EY 5-4-6421
1	1610	2.024-39	3.000	4.875	EY 5-4-6421-1

Pos	Series	Spline Data	Hub Dia	* to End of Hub	End Fitting Part Number
-----	--------	-------------	---------	-----------------	-------------------------

SQ-100 (Continued)					
1	1610	2.024-39	3.000	4.875	EY 5-4-6431-1X
1	1610	2.024-39	3.000	4.875	EY 5-4-6431X
1	1710	2.024-39	3.000	6.250	EY 6-4-6371 <i>High angle yoke</i>
1	1710	2.024-39	3.000	6.250	EY 6-4-6371-1 <i>High angle yoke</i>
1	1710	2.024-39	3.000	6.250	EY 6-4-6381X <i>High angle yoke</i>
1	1710	2.024-39	3.000	5.156	EY 6-4-6401
1	1710	2.024-39	3.000	5.156	EY 6-4-6401-1
1	1710	2.024-39	3.000	5.156	EY 6-4-7621-1
1	1710	2.024-39	3.000	5.156	EY 6-4-7631-1X
1	1760	2.024-39	3.000	5.188	EY 6.3-4-531
1	1760	2.024-39	3.000	5.188	EY 6.3-4-531-1
1	1760	2.024-39	3.000	5.188	EY 6.3-4-541-1X
1	1760	2.024-39	3.000	5.188	EY 6.3-4-541X
1	1810	2.024-39	3.000	5.190	EY 6.5-4-3371
1	1810	2.024-39	3.000	5.190	EY 6.5-4-3371-1
1	1810	2.024-39	3.000	5.190	EY 6.5-4-3381-1X
1	1810	2.024-39	3.000	5.190	EY 6.5-4-3381X
2	1610	2.250-10	3.500	3.625	CF 5-1-6331
2	SPL170	1.774-34	2.500	5.031	EY 170-4-621-1
2	SPL170	1.774-34	2.500	6.440	EY 170-4-631-1 <i>High angle yoke</i>
2	1610	1.774-34	2.500	6.062	EY 5-4-6251 <i>High angle yoke</i>
2	1610	1.774-34	2.500	5.438	EY 5-4-6261
2	1610	1.774-34	2.500	5.438	EY 5-4-6261-1
2	1710	1.774-34	2.500	5.969	EY 6-4-6321 <i>High angle yoke</i>
2	1710	1.774-34	2.500	5.969	EY 6-4-6321-1 <i>High angle yoke</i>
2	1710	1.774-34	2.500	4.875	EY 6-4-6331
2	1710	1.774-34	2.500	4.875	EY 6-4-6331-1
2	1760	2.024-39	3.000	5.188	EY 6.3-4-1141-1X
3	SPL140	2.024-39	3.000	5.680	EY 140-4-211-1
3	SPL140	2.024-39	3.000	5.680	EY 140-4-231-1X
3	SPL170	1.774-34	2.500	6.440	EY 170-4-09705-1X <i>High angle yoke</i>
3	SPL170	2.024-39	3.000	5.090	EY 170-4-641-1
3	SPL170	2.024-39	3.000	5.090	EY 170-4-651-1X
3	SPL170	2.024-39	3.000	6.391	EY 170-4-661-1 <i>High angle yoke</i>
3	SPL170	2.024-39	3.000	6.391	EY 170-4-671-1X <i>High angle yoke</i>
3	SPL170	2.024-39	3.000	5.090	EY 170-4-681-1X
3	SPL170	1.774-34	2.500	6.440	EY 5009705 <i>High angle yoke</i>
3	SPL90	2.024-39	3.000	4.625	EY 90-4-311-1
3	SPL90	2.024-39	3.000	4.625	EY 90-4-321-1X

*C/L to End of Hub for EY (End Yoke); Flange Face to End of Hub for CF (Companion Flange)

■ Hub machined for speedometer gear





Pos	Series	Spline Data	Hub Dia	* to End of Hub	End Fitting Part Number
SQ-100 (Continued)					
3	1480	2.024-39	3.000	4.281	EY 3-4-8861
3	1480	2.024-39	3.000	4.281	EY 3-4-8871X
3	1550	2.024-39	3.000	5.000	EY 4-4-5261-1
3	1550	2.024-39	3.000	5.000	EY 4-4-6731-1X
3	1610	2.024-39	3.000	6.219	EY 5-4-6241 <i>High angle yoke</i>
3	1610	2.024-39	3.000	6.219	EY 5-4-6241-1 <i>High angle yoke</i>
3	1610	2.024-39	3.000	5.531	EY 5-4-6271
3	1610	2.024-39	3.000	5.531	EY 5-4-6281X
3	1610	2.024-39	3.000	6.219	EY 5-4-6291-1X <i>High angle yoke</i>
3	1610	2.024-39	3.000	6.219	EY 5-4-6291X <i>High angle yoke</i>
3	1610	2.024-39	3.000	4.875	EY 5-4-6421-1
3	1610	2.024-39	3.000	4.875	EY 5-4-6441-1X
3	1710	2.024-39	3.000	6.250	EY 6-4-6371 <i>High angle yoke</i>
3	1710	2.024-39	3.000	6.250	EY 6-4-6371-1 <i>High angle yoke</i>
3	1710	2.024-39	3.000	6.250	EY 6-4-6391-1X <i>High angle yoke</i>
3	1710	2.024-39	3.000	6.250	EY 6-4-6391X <i>High angle yoke</i>
3	1710	2.024-39	3.000	5.156	EY 6-4-6401
3	1710	2.024-39	3.000	5.156	EY 6-4-6401-1
3	1710	2.024-39	3.000	5.156	EY 6-4-6421X
3	1710	2.024-39	3.000	5.156	EY 6-4-7621-1
3	1710	2.024-39	3.000	5.156	EY 6-4-7641-1X
3	1760	2.024-39	3.000	5.188	EY 6.3-4-1141-1X
3	1760	2.024-39	3.000	5.188	EY 6.3-4-531
3	1760	2.024-39	3.000	5.188	EY 6.3-4-531-1
3	1810	2.024-39	3.000	5.190	EY 6.5-4-3371
3	1810	2.024-39	3.000	5.190	EY 6.5-4-3371-1
3	1810	2.024-39	3.000	5.190	EY 6.5-4-3381-1X
3	1810	2.024-39	3.000	5.190	EY 6.5-4-3381X

Pos	Series	Spline Data	Hub Dia	* to End of Hub	End Fitting Part Number
SQ-100P					
1	1610	2.024-39	3.000	5.531	EY 5-4-6281X
1	1610	2.024-39	3.000	4.875	EY 5-4-6431-1X
1	1610	2.024-39	3.000	4.875	EY 5-4-6431X
1	1710	2.024-39	3.000	6.250	EY 6-4-6381X <i>High angle yoke</i>
1	1710	2.024-39	3.000	5.156	EY 6-4-6411X
1	1710	2.024-39	3.000	5.156	EY 6-4-7631-1X
1	1760	2.024-39	3.000	5.188	EY 6.3-4-541-1X
1	1760	2.024-39	3.000	5.188	EY 6.3-4-541X
1	1810	2.024-39	3.000	5.190	EY 6.5-4-3381-1X
1	1810	2.024-39	3.000	5.190	EY 6.5-4-3381X
1	1810	2.024-39	3.000	5.188	EY 6.5-4-3851-1X
2	1610	2.250-10	3.500	3.625	CF 5-1-6331
2	1610	1.774-34	2.500	6.062	EY 5-4-6251 <i>High angle yoke</i>
2	1610	1.774-34	2.500	5.438	EY 5-4-6261
2	1710	1.774-34	2.500	5.969	EY 6-4-6321 <i>High angle yoke</i>
2	1710	1.774-34	2.500	4.875	EY 6-4-6331 <i>High angle yoke</i>
3	1610	2.024-39	3.000	5.531	EY 5-4-6281X
3	1610	2.024-39	3.000	6.219	EY 5-4-6291X <i>High angle yoke</i>
3	1610	2.024-39	3.000	4.875	EY 5-4-6431-1X

Pos	Series	Spline Data	Hub Dia	* to End of Hub	End Fitting Part Number
SQ-100P (Continued)					
3	1610	2.024-39	3.000	4.875	EY 5-4-6431X
3	1610	2.024-39	3.000	4.875	EY 5-4-6441-1X
3	1710	2.024-39	3.000	6.250	EY 6-4-6391X <i>High angle yoke</i>
3	1710	2.024-39	3.000	5.156	EY 6-4-6421-1X
3	1710	2.024-39	3.000	5.156	EY 6-4-6421X
3	1710	2.024-39	3.000	5.156	EY 6-4-7631-1X
3	1710	2.024-39	3.000	5.156	EY 6-4-7641-1X
3	1710	2.024-39	3.000	5.156	EY 6-4-8601-1X
3	1760	2.024-39	3.000	5.188	EY 6.3-4-1141-1X
3	1760	2.024-39	3.000	5.188	EY 6.3-4-541-1X
3	1760	2.024-39	3.000	5.188	EY 6.3-4-541X

Pos	Series	Spline Data	Hub Dia	* to End of Hub	End Fitting Part Number
SQD					
1	1610	2.000-10	2.938	5.188	EY 5-4-5131X
1	1710	2.000-10	2.938	5.188	EY 6-4-4291X
1	1710	2.000-10	2.938	5.188	EY 6-4-4741X
1	1810	2.000-10	2.938	5.375	EY 6.5-4-2341X
2	1610	2.000-10	2.938	5.188	EY 5-4-5131X
2	1710	2.000-10	2.938	5.188	EY 6-4-4291X
2	1710	2.000-10	2.938	5.188	EY 6-4-4741X
2	1810	2.000-10	2.938	5.375	EY 6.5-4-2341X
3	1610	2.000-10	2.938	5.188	EY 5-4-5131X
3	1710	2.000-10	2.938	5.188	EY 6-4-4291X
3	1710	2.000-10	2.938	5.188	EY 6-4-4741X
3	1810	2.000-10	2.938	5.375	EY 6.5-4-2341X

Pos	Series	Spline Data	Hub Dia	* to End of Hub	End Fitting Part Number
SQDD					
1	1710	2.000-10	2.750	5.188	EY 6-4-4391X
2	1610	2.000-10	2.938	5.188	EY 5-4-5131X
2	1710	2.000-10	2.938	5.188	EY 6-4-4291X
2	1710	2.000-10	2.938	5.188	EY 6-4-4741X
3	1610	2.000-10	2.938	5.188	EY 5-4-5131X
3	1710	2.000-10	2.938	5.188	EY 6-4-4291X
3	1710	2.000-10	2.938	5.188	EY 6-4-4741X

Pos	Series	Spline Data	Hub Dia	* to End of Hub	End Fitting Part Number
SQHD					
1	1710	1.750-10	2.750	2.938	CF 6-1-1761
1	1610	2.000-10	2.938	5.188	EY 5-4-5131X
1	1710	2.000-10	2.938	5.188	EY 6-4-3241
1	1710	2.000-10	2.938	5.188	EY 6-4-4291X
1	1760	2.000-10	2.938	5.375	EY 6.3-4-181X
1	1810	2.000-10	2.938	5.375	EY 6.5-4-2341X
2	1610	1.750-10	2.750	5.000	EY 5-4-3621
2	1610	1.750-10	2.750	5.406	EY 5-4-4481
2	1710	1.750-10	2.750	4.875	EY 6-4-2381
2	1710	1.750-10	2.750	6.250	EY 6-4-4831X
3	1710	1.750-10	2.750	6.250	EY 6-4-4831X

Pos	Series	Spline Data	Hub Dia	* to End of Hub	End Fitting Part Number
SQHP					
1	1610	2.024-39	3.000	5.531	EY 5-4-6281X
1	1610	2.024-39	3.000	4.875	EY 5-4-6431-1X
1	1610	2.024-39	3.000	4.875	EY 5-4-6431X
1	1710	2.024-39	3.000	5.188	EY 6-4-5101X
1	1710	2.024-39	3.000	6.250	EY 6-4-6371-1 <i>High angle yoke</i>
1	1710	2.024-39	3.000	6.250	EY 6-4-6381X <i>High angle yoke</i>
1	1710	2.024-39	3.000	6.250	EY 6-4-6391-1X <i>High angle yoke</i>
1	1710	2.024-39	3.000	5.156	EY 6-4-6401 <i>High angle yoke</i>

Continued on next page

*C/L to End of Hub for EY (End Yoke); Flange Face to End of Hub for CF (Companion Flange)

■ Hub machined for speedometer gear



Important: See Safety Information in General Information Section (J300P-GI)

TANDEM AXLES

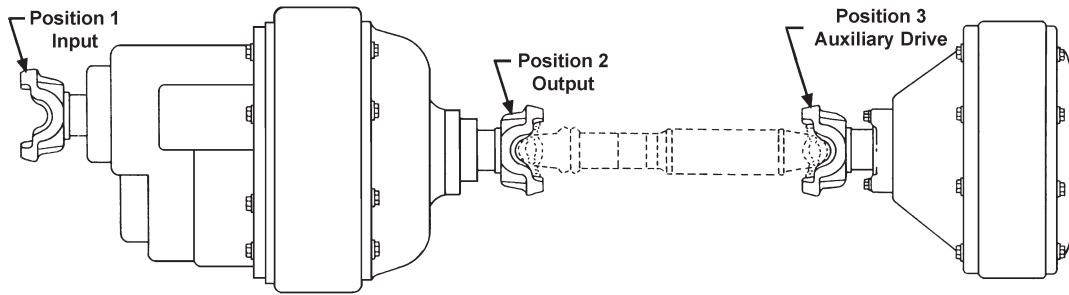

Pos	Series	Spline Data	Hub Dia	* to End of Hub	End Fitting Part Number
-----	--------	-------------	---------	-----------------	-------------------------

SQHP (Continued)

1	1710	2.024-39	3.000	5.156	EY 6-4-6401-1
1	1710	2.024-39	3.000	5.156	EY 6-4-6411X
1	1710	2.024-39	3.000	5.156	EY 6-4-7621-1
1	1710	2.024-39	3.000	5.156	EY 6-4-7631-1X
1	1760	2.024-39	3.000	5.188	EY 6.3-4-191X
1	1760	2.024-39	3.000	5.188	EY 6.3-4-531
1	1760	2.024-39	3.000	5.188	EY 6.3-4-531-1
1	1760	2.024-39	3.000	5.188	EY 6.3-4-541-1X
1	1760	2.024-39	3.000	5.188	EY 6.3-4-541X
1	1810	2.024-39	3.000	5.188	EY 6.5-4-2491X
1	1810	2.024-39	3.000	5.190	EY 6.5-4-3371
1	1810	2.024-39	3.000	5.190	EY 6.5-4-3371-1
1	1810	2.024-39	3.000	5.190	EY 6.5-4-3381-1X
1	1810	2.024-39	3.000	5.190	EY 6.5-4-3381X
1	1810	2.024-39	3.000	5.750	EY 6.5-4-3881-1X
2	1610	1.774-34	2.500	6.062	EY 5-4-6251 <i>High angle yoke</i>
2	1610	1.774-34	2.500	5.438	EY 5-4-6261 <i>High angle yoke</i>
2	1710	1.774-34	2.500	4.875	EY 6-4-6331
2	1760	2.024-39	3.000	5.188	EY 6.3-4-1141-1X
3	1610	2.024-39	3.000	5.531	EY 5-4-6281X
3	1610	2.024-39	3.000	6.219	EY 5-4-6291X <i>High angle yoke</i>
3	1610	2.024-39	3.000	4.875	EY 5-4-6431-1X
3	1610	2.024-39	3.000	4.875	EY 5-4-6431X
3	1610	2.024-39	3.000	4.875	EY 5-4-6441-1X
3	1710	2.024-39	3.000	6.250	EY 6-4-6391X <i>High angle yoke</i>
3	1710	2.024-39	3.000	5.156	EY 6-4-6401
3	1710	2.024-39	3.000	5.156	EY 6-4-6421-1X
3	1710	2.024-39	3.000	5.156	EY 6-4-6421X
3	1710	2.024-39	3.000	5.156	EY 6-4-7621-1
3	1710	2.024-39	3.000	5.156	EY 6-4-7631-1X
3	1710	2.024-39	3.000	5.156	EY 6-4-7641-1X
3	1710	2.024-39	3.000	5.156	EY 6-4-8601-1X
3	1760	2.024-39	3.000	5.188	EY 6.3-4-1141-1X

SQHP-P

1	1810	2.024-39	3.000	5.188	EY 6.5-4-3851-1X
---	------	----------	-------	-------	------------------

SQR-100

1	1610	2.024-39	3.000	5.531	EY 5-4-6281X
1	1610	2.024-39	3.000	4.875	EY 5-4-6431-1X
1	1610	2.024-39	3.000	4.875	EY 5-4-6431X
1	1710	2.024-39	3.000	6.250	EY 6-4-6381X <i>High angle yoke</i>
1	1710	2.024-39	3.000	5.156	EY 6-4-6401
1	1710	2.024-39	3.000	5.156	EY 6-4-6401-1
1	1710	2.024-39	3.000	5.156	EY 6-4-6411X

Pos	Series	Spline Data	Hub Dia	* to End of Hub	End Fitting Part Number
-----	--------	-------------	---------	-----------------	-------------------------

SQR-100 (Continued)

1	1710	2.024-39	3.000	5.156	EY 6-4-7621-1
1	1710	2.024-39	3.000	5.156	EY 6-4-7631-1X
1	1760	2.024-39	3.000	5.188	EY 6.3-4-531
1	1760	2.024-39	3.000	5.188	EY 6.3-4-531-1
1	1760	2.024-39	3.000	5.188	EY 6.3-4-541-1X
1	1760	2.024-39	3.000	5.188	EY 6.3-4-541X
1	1810	2.024-39	3.000	5.190	EY 6.5-4-3381-1X
1	1810	2.024-39	3.000	5.190	EY 6.5-4-3381X
1	1810	2.024-39	3.000	5.750	EY 6.5-4-3881-1X
2	1610	1.774-34	2.500	6.062	EY 5-4-6251 <i>High angle yoke</i>
2	1610	1.774-34	2.500	5.438	EY 5-4-6261
2	1710	1.774-34	2.500	5.969	EY 6-4-6321 <i>High angle yoke</i>
2	1710	1.774-34	2.500	4.875	EY 6-4-6331
2	1760	2.024-39	3.000	5.188	EY 6.3-4-1141-1X
3	1610	2.024-39	3.000	5.531	EY 5-4-6281X
3	1610	2.024-39	3.000	6.219	EY 5-4-6291X <i>High angle yoke</i>
3	1610	2.024-39	3.000	4.875	EY 5-4-6431-1X
3	1610	2.024-39	3.000	4.875	EY 5-4-6431X
3	1610	2.024-39	3.000	4.875	EY 5-4-6441-1X
3	1710	2.024-39	3.000	6.250	EY 6-4-6391X <i>High angle yoke</i>
3	1710	2.024-39	3.000	5.156	EY 6-4-6401
3	1710	2.024-39	3.000	5.156	EY 6-4-6421-1X
3	1710	2.024-39	3.000	5.156	EY 6-4-6421X
3	1710	2.024-39	3.000	5.156	EY 6-4-7621-1
3	1710	2.024-39	3.000	5.156	EY 6-4-7631-1X
3	1710	2.024-39	3.000	5.156	EY 6-4-7641-1X
3	1710	2.024-39	3.000	5.156	EY 6-4-8601-1X
3	1760	2.024-39	3.000	5.188	EY 6.3-4-1141-1X

SQR-100P

1	1610	2.024-39	3.000	5.531	EY 5-4-6281X
1	1610	2.024-39	3.000	4.875	EY 5-4-6431-1X
1	1610	2.024-39	3.000	4.875	EY 5-4-6431X
1	1710	2.024-39	3.000	6.250	EY 6-4-6381X <i>High angle yoke</i>
1	1710	2.024-39	3.000	5.156	EY 6-4-6401
1	1710	2.024-39	3.000	5.156	EY 6-4-6401-1
1	1710	2.024-39	3.000	5.156	EY 6-4-6411X
1	1710	2.024-39	3.000	5.156	EY 6-4-7621-1
1	1710	2.024-39	3.000	5.156	EY 6-4-7631-1X
1	1760	2.024-39	3.000	5.188	EY 6.3-4-531
1	1760	2.024-39	3.000	5.188	EY 6.3-4-531-1
1	1760	2.024-39	3.000	5.188	EY 6.3-4-541-1X
1	1760	2.024-39	3.000	5.188	EY 6.3-4-541X
1	1810	2.024-39	3.000	5.190	EY 6.5-4-3381-1X

*C/L to End of Hub for EY (End Yoke); Flange Face to End of Hub for CF (Companion Flange)

■ Hub machined for speedometer gear



Pos	Series	Spline Data	Hub Dia	* to End of Hub	End Fitting Part Number
SQR-100P (Continued)					
1	1810	2.024-39	3.000	5.190	EY 6.5-4-3381X
2	1610	1.774-34	2.500	6.062	EY 5-4-6251 <i>High angle yoke</i>
2	1610	1.774-34	2.500	5.438	EY 5-4-6261
2	1710	1.774-34	2.500	5.969	EY 6-4-6321 <i>High angle yoke</i>
2	1710	1.774-34	2.500	4.875	EY 6-4-6331
3	1610	2.024-39	3.000	5.531	EY 5-4-6281X
3	1610	2.024-39	3.000	6.219	EY 5-4-6291X <i>High angle yoke</i>
3	1610	2.024-39	3.000	4.875	EY 5-4-6431-1X
3	1610	2.024-39	3.000	4.875	EY 5-4-6431X
3	1610	2.024-39	3.000	4.875	EY 5-4-6441-1X
3	1710	2.024-39	3.000	6.250	EY 6-4-6391X <i>High angle yoke</i>
3	1710	2.024-39	3.000	5.156	EY 6-4-6421-1X
3	1710	2.024-39	3.000	5.156	EY 6-4-6421X
3	1710	2.024-39	3.000	5.156	EY 6-4-7631-1X
3	1710	2.024-39	3.000	5.156	EY 6-4-7641-1X
3	1710	2.024-39	3.000	5.156	EY 6-4-8601-1X
3	1760	2.024-39	3.000	5.188	EY 6.3-4-1141-1X
3	1760	2.024-39	3.000	5.188	EY 6.3-4-541X

Pos	Series	Spline Data	Hub Dia	* to End of Hub	End Fitting Part Number
SR-170					
1	1710	2.374-46	3.250	5.938	EY 6-4-5961X
1	1760	2.374-46	3.250	5.625	EY 6.3-4-301-1X
1	1760	2.374-46	3.250	5.625	EY 6.3-4-301X
1	1810	2.374-46	3.250	5.688	EY 6.5-4-3221-1X
1	1810	2.374-46	3.250	5.688	EY 6.5-4-3221X
2	1610	2.024-39	3.000	5.531	EY 5-4-6271
2	1710	2.024-39	3.000	5.156	EY 6-4-6401
2	1710	2.024-39	3.000	5.156	EY 6-4-6401-1
2	1760	2.024-39	3.000	5.188	EY 6.3-4-531
2	1810	2.024-39	3.000	5.190	EY 6.5-4-3371
3	1610	2.250-10	3.000	5.625	EY 5-4-6891X
3	1710	2.250-10	3.000	6.062	EY 6-4-4411-1X
3	1710	2.250-10	3.000	6.062	EY 6-4-4411X
3	1710	2.250-10	3.000	7.188	EY 6-4-6891X <i>High angle yoke</i>
3	1760	2.250-10	3.000	5.844	EY 6.3-4-731-1X
3	1760	2.250-10	3.000	5.844	EY 6.3-4-731X
3	1810	2.250-10	3.000	5.844	EY 6.5-4-2551X

Pos	Series	Spline Data	Hub Dia	* to End of Hub	End Fitting Part Number
SR-270SR-280					
1	1760	2.374-46	3.250	5.625	EY 6.3-4-301-1X
1	1760	2.374-46	3.250	5.625	EY 6.3-4-301X
1	1810	2.374-46	3.250	5.688	EY 6.5-4-3221-1X
1	1810	2.374-46	3.250	5.688	EY 6.5-4-3221X
2	1610	2.024-39	3.000	5.531	EY 5-4-6271
2	1710	2.024-39	3.000	5.156	EY 6-4-6401
2	1710	2.024-39	3.000	5.156	EY 6-4-6401-1
2	1760	2.024-39	3.000	5.188	EY 6.3-4-531
2	1810	2.024-39	3.000	5.190	EY 6.5-4-3371
3	1710	2.024-39	3.000	6.250	EY 6-4-6381X <i>High angle yoke</i>
3	1710	2.024-39	3.000	6.250	EY 6-4-6391X <i>High angle yoke</i>
3	1810	2.024-39	3.000	5.190	EY 6.5-4-3381X

Pos	Series	Spline Data	Hub Dia	* to End of Hub	End Fitting Part Number
SRD					
1	1650/1710	2.250-10	3.000	3.750	CF 6-1-1421 <i>.250 deep counterbore at hub end</i>
1	1810	2.250-10	3.000	3.750	CF 6.5-1-211 <i>.250 deep counterbore at hub end</i>
1	1610	2.250-10	3.000	5.625	EY 5-4-6891X
1	1710	2.250-10	3.000	6.062	EY 6-4-4411X
1	1810	2.250-10	3.000	5.844	EY 6.5-4-2551X
2	1610	2.250-10	3.000	5.625	EY 5-4-6891X
2	1710	2.250-10	3.000	6.062	EY 6-4-4411X
2	1810	2.250-10	3.000	5.844	EY 6.5-4-2551X
3	1610	2.250-10	3.000	5.625	EY 5-4-6891X
3	1710	2.250-10	3.000	6.062	EY 6-4-4411X
3	1810	2.250-10	3.000	5.844	EY 6.5-4-2551X

Pos	Series	Spline Data	Hub Dia	* to End of Hub	End Fitting Part Number
SRDD					
1	1650/1710	2.250-10	3.000	3.750	CF 6-1-1421 <i>.250 deep counterbore at hub end</i>
1	1610	2.250-10	3.000	5.625	EY 5-4-6891X
1	1710	2.250-10	3.000	6.062	EY 6-4-1991
1	1710	2.250-10	3.000	6.062	EY 6-4-1991-1
1	1710	2.250-10	3.000	6.062	EY 6-4-4411-1X
1	1710	2.250-10	3.000	6.062	EY 6-4-4411X
1	1710	2.374-46	3.250	5.688	EY 6-4-5461-1X
1	1710	2.374-46	3.250	5.688	EY 6-4-5461X
1	1760	2.374-46	3.250	5.438	EY 6.3-4-101
1	1760	2.374-46	3.250	5.438	EY 6.3-4-101-1
1	1760	2.374-46	3.250	5.438	EY 6.3-4-211-1X
1	1760	2.374-46	3.250	5.438	EY 6.3-4-211X
1	1810	2.374-46	3.250	5.438	EY 6.5-4-2701
1	1810	2.374-46	3.250	5.438	EY 6.5-4-2701-1
1	1810	2.374-46	3.250	5.438	EY 6.5-4-2711-1X
1	1810	2.374-46	3.250	5.438	EY 6.5-4-2711X
2	1610	1.960-10	2.750	5.125	EY 5-4-5281X
2	1610	1.962-10	2.750	5.938	EY 5-4-5321X
2	1610	2.250-10	3.000	5.625	EY 5-4-6891X
2	1610	2.024-39	2.750	5.125	EY 5-4-6951X
2	1610	2.024-39	2.750	5.938	EY 5-4-6961X <i>High angle yoke</i>
2	1710	1.960-10	2.750	5.250	EY 6-4-4361X
2	1710	2.250-10	3.000	6.062	EY 6-4-4411X
2	1710	1.960-10	2.750	6.500	EY 6-4-4481X <i>High angle yoke</i>
2	1710	2.024-39	2.750	6.500	EY 6-4-5501-1 <i>High angle yoke</i>
2	1710	2.024-39	2.750	6.500	EY 6-4-6871-1X <i>High angle yoke</i>
2	1710	2.024-39	2.750	6.500	EY 6-4-6871X
2	1710	2.024-39	2.750	4.812	EY 6-4-6941X
2	1710	2.024-39	2.750	5.250	EY 6-4-6951X
2	1810	2.250-10	3.000	5.844	EY 6.5-4-2551X
2	1810	2.024-39	2.750	5.531	EY 6.5-4-3571X
3	1610	1.960-10	2.750	5.125	EY 5-4-5281X
3	1610	1.962-10	2.750	5.938	EY 5-4-5321X
3	1610	2.250-10	3.000	5.625	EY 5-4-6891X
3	1610	2.024-39	2.750	5.125	EY 5-4-6951X
3	1610	2.024-39	2.750	5.938	EY 5-4-6961X <i>High angle yoke</i>
3	1710	1.960-10	2.750	5.250	EY 6-4-4361X
3	1710	2.250-10	3.000	6.062	EY 6-4-4411X

Continued on next page

*C/L to End of Hub for EY (End Yoke); Flange Face to End of Hub for CF (Companion Flange)

■ Hub machined for speedometer gear



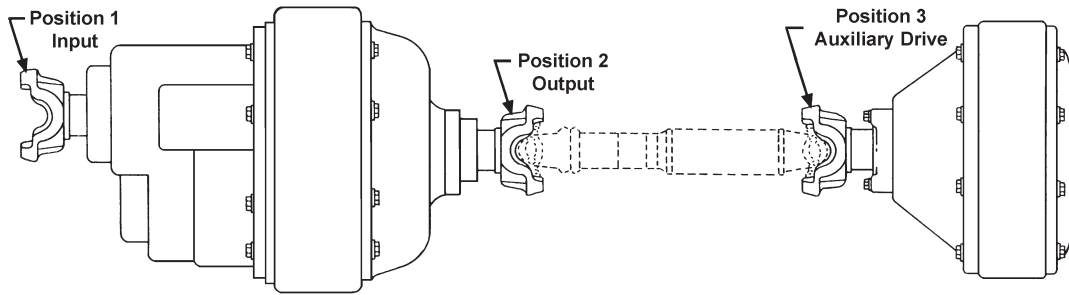

Pos	Series	Spline Data	Hub Dia	* to End of Hub	End Fitting Part Number
-----	--------	-------------	---------	-----------------	-------------------------

SRDD (Continued)

3	1710	1.960-10	2.750	6.500	EY 6-4-4481X <i>High angle yoke</i>
3	1710	2.024-39	2.750	6.500	EY 6-4-5501-1 <i>High angle yoke</i>
3	1710	2.024-39	2.750	6.500	EY 6-4-6871-1X <i>High angle yoke</i>
3	1710	2.024-39	2.750	6.500	EY 6-4-6871X
3	1710	2.024-39	2.750	4.812	EY 6-4-6941X
3	1710	2.024-39	2.750	5.250	EY 6-4-6951X
3	1810	2.250-10	3.000	5.844	EY 6.5-4-2551X
3	1810	2.024-39	2.750	5.625	EY 6.5-4-3571-1X
3	1810	2.024-39	2.750	5.531	EY 6.5-4-3571X

SRHD

1	1650/1710	2.250-10	3.000	3.750	CF 6-1-1421 .250 deep counterbore at hub end
1	1810	2.250-10	3.000	3.750	CF 6.5-1-211 .250 deep counterbore at hub end
1	1610	2.250-10	3.000	5.625	EY 5-4-6891X
1	1710	2.250-10	3.000	6.062	EY 6-4-1991
1	1710	2.250-10	3.000	6.062	EY 6-4-1991-1
1	1710	2.250-10	3.000	6.062	EY 6-4-4411-1X
1	1710	2.250-10	3.000	6.062	EY 6-4-4411X
1	1710	2.250-10	3.000	7.188	EY 6-4-6891X <i>High angle yoke</i>
1	1810	2.250-10	3.000	5.844	EY 6.5-4-2551X
2	1610	1.962-10	2.750	5.938	EY 5-4-5321X
2	1710	1.960-10	2.750	5.250	EY 6-4-4361X
2	1710	1.960-10	2.750	6.500	EY 6-4-4481X <i>High angle yoke</i>
3	1480	1.875-10	2.750	4.406	EY 3-4-6671-1X
3	1550	1.875-10	2.750	4.406	EY 4-4-1941
3	1610	1.875-10	2.750	5.000	EY 5-4-2501

SSHD

1	SPL250	2.374-46	3.250	5.610	EY 250-4-771-1
1	SPL250	2.374-46	3.250	5.610	EY 250-4-781-1X
1	1710	2.250-10	3.000	6.062	EY 6-4-1991
1	1710	2.374-46	3.250	5.688	EY 6-4-5461-1X
1	1710	2.374-46	3.250	5.688	EY 6-4-5461X
1	1760	2.374-46	3.250	5.438	EY 6.3-4-101
1	1760	2.374-46	3.250	5.438	EY 6.3-4-101-1
1	1760	2.374-46	3.250	5.438	EY 6.3-4-211-1X
1	1760	2.374-46	3.250	5.438	EY 6.3-4-211X
1	1810	2.374-46	3.250	5.438	EY 6.5-4-2701
1	1810	2.374-46	3.250	5.438	EY 6.5-4-2701-1
1	1810	2.374-46	3.250	5.438	EY 6.5-4-2711-1X
1	1810	2.374-46	3.250	5.438	EY 6.5-4-2711X
2	SPL140	2.024-39	2.750	5.250	EY 140-4-1421-1
2	1610	1.960-10	2.750	5.125	EY 5-4-5281X

Pos	Series	Spline Data	Hub Dia	* to End of Hub	End Fitting Part Number
-----	--------	-------------	---------	-----------------	-------------------------

SSHD (Continued)

2	1610	1.962-10	2.750	5.938	EY 5-4-5321X
2	1610	2.024-39	2.750	5.125	EY 5-4-5421
2	1610	2.024-39	2.750	5.938	EY 5-4-5441 <i>High angle yoke</i>
2	1610	2.024-39	2.750	5.125	EY 5-4-6951X
2	1610	2.024-39	2.750	5.938	EY 5-4-6961X <i>High angle yoke</i>
2	1710	1.960-10	2.750	5.250	EY 6-4-3221
2	1710	1.960-10	2.750	5.250	EY 6-4-3221-1
2	1710	1.960-10	2.750	5.250	EY 6-4-4361X
2	1710	1.960-10	2.750	6.500	EY 6-4-4481X <i>High angle yoke</i>
2	1710	2.024-39	2.750	6.500	EY 6-4-5501
2	1710	2.024-39	2.750	6.500	EY 6-4-5501-1 <i>High angle yoke</i>
2	1710	2.024-39	2.750	5.250	EY 6-4-5521
2	1710	2.024-39	2.750	5.250	EY 6-4-5521-1
2	1710	2.024-39	2.750	6.500	EY 6-4-6871-1X <i>High angle yoke</i>
2	1710	2.024-39	2.750	6.500	EY 6-4-6871X
2	1710	2.024-39	2.750	4.812	EY 6-4-6941X
2	1710	2.024-39	2.750	5.250	EY 6-4-6951-1X
2	1710	2.024-39	2.750	5.250	EY 6-4-6951X
2	1810	2.024-39	2.750	5.531	EY 6.5-4-2781
2	1810	2.024-39	2.750	5.625	EY 6.5-4-2781-1
2	1810	2.024-39	2.750	5.625	EY 6.5-4-3571-1X
2	1810	2.024-39	2.750	5.531	EY 6.5-4-3571X
3	SPL140	2.024-39	2.750	5.250	EY 140-4-1421-1
3	SPL140	2.024-39	2.750	5.250	EY 140-4-1431-1X
3	1610	1.960-10	2.750	5.125	EY 5-4-5281X
3	1610	1.962-10	2.750	5.938	EY 5-4-5321X
3	1610	2.024-39	2.750	5.125	EY 5-4-5421
3	1610	2.024-39	2.750	5.125	EY 5-4-6951X
3	1610	2.024-39	2.750	5.938	EY 5-4-6961X <i>High angle yoke</i>
3	1710	1.960-10	2.750	5.250	EY 6-4-3221
3	1710	1.960-10	2.750	5.250	EY 6-4-3221-1
3	1710	1.960-10	2.750	5.250	EY 6-4-4361X
3	1710	1.960-10	2.750	6.500	EY 6-4-4481X <i>High angle yoke</i>
3	1710	2.024-39	2.750	6.500	EY 6-4-5501
3	1710	2.024-39	2.750	6.500	EY 6-4-5501-1 <i>High angle yoke</i>
3	1710	2.024-39	2.750	5.250	EY 6-4-5521
3	1710	2.024-39	2.750	5.250	EY 6-4-5521-1
3	1710	2.024-39	2.750	6.500	EY 6-4-6871-1X <i>High angle yoke</i>
3	1710	2.024-39	2.750	6.500	EY 6-4-6871X
3	1710	2.024-39	2.750	4.812	EY 6-4-6941X

*C/L to End of Hub for EY (End Yoke); Flange Face to End of Hub for CF (Companion Flange)

■ Hub machined for speedometer gear



Pos	Series	Spline Data	Hub Dia	* to End of Hub	End Fitting Part Number
SSHD (Continued)					
3	1710	2.024-39	2.750	5.250	EY 6-4-6951-1X
3	1710	2.024-39	2.750	5.250	EY 6-4-6951X
3	1810	2.024-39	2.750	5.531	EY 6.5-4-2781
3	1810	2.024-39	2.750	5.625	EY 6.5-4-2781-1
3	1810	2.024-39	2.750	5.625	EY 6.5-4-3571-1X
3	1810	2.024-39	2.750	5.531	EY 6.5-4-3571X

SSHF					
1	1760	2.374-46	3.250	5.438	EY 6.3-4-101
1	1760	2.374-46	3.250	5.438	EY 6.3-4-101-1
1	1810	2.374-46	3.250	5.438	EY 6.5-4-2701
1	1810	2.374-46	3.250	5.438	EY 6.5-4-2701-1

ST-170					
1	1710	2.374-46	3.250	5.938	EY 6-4-5961X
1	1760	2.374-46	3.250	5.625	EY 6.3-4-301-1X
1	1760	2.374-46	3.250	5.625	EY 6.3-4-301X
1	1810	2.374-46	3.250	5.688	EY 6.5-4-3221-1X
1	1810	2.374-46	3.250	5.688	EY 6.5-4-3221X
2	1610	2.024-39	3.000	5.531	EY 5-4-6271
2	1710	2.024-39	3.000	5.156	EY 6-4-6401
2	1710	2.024-39	3.000	5.156	EY 6-4-6401-1
2	1760	2.024-39	3.000	5.188	EY 6.3-4-531
2	1810	2.024-39	3.000	5.190	EY 6.5-4-3371
3	1610	2.250-10	3.000	5.625	EY 5-4-6891X
3	1710	2.250-10	3.000	6.062	EY 6-4-4411-1X
3	1710	2.250-10	3.000	6.062	EY 6-4-4411X
3	1710	2.250-10	3.000	7.188	EY 6-4-6891X <i>High angle yoke</i>
3	1760	2.250-10	3.000	5.844	EY 6.3-4-731-1X
3	1760	2.250-10	3.000	5.844	EY 6.3-4-731X
3	1810	2.250-10	3.000	5.844	EY 6.5-4-2551X

ST-270, ST-280					
1	1760	2.374-46	3.250	5.625	EY 6.3-4-301-1X
1	1760	2.374-46	3.250	5.625	EY 6.3-4-301X
1	1810	2.374-46	3.250	5.688	EY 6.5-4-3221-1X
1	1810	2.374-46	3.250	5.688	EY 6.5-4-3221X
2	1610	2.024-39	3.000	5.531	EY 5-4-6271
2	1710	2.024-39	3.000	5.156	EY 6-4-6401
2	1710	2.024-39	3.000	5.156	EY 6-4-6401-1
2	1760	2.024-39	3.000	5.188	EY 6.3-4-531
2	1810	2.024-39	3.000	5.190	EY 6.5-4-3371
3	1610	2.250-10	3.000	5.625	EY 5-4-6891X
3	1710	2.250-10	3.000	6.062	EY 6-4-4411-1X
3	1710	2.250-10	3.000	6.062	EY 6-4-4411X
3	1710	2.250-10	3.000	7.188	EY 6-4-6891X <i>High angle yoke</i>
3	1760	2.250-10	3.000	5.844	EY 6.3-4-731-1X
3	1760	2.250-10	3.000	5.844	EY 6.3-4-731X
3	1810	2.250-10	3.000	5.844	EY 6.5-4-2551X

STDD					
1	1710	2.250-10	3.000	6.062	EY 6-4-1991
1	1710	2.250-10	3.000	6.062	EY 6-4-1991-1
1	1710	2.250-10	3.000	6.062	EY 6-4-4411-1X
1	1710	2.374-46	3.250	5.688	EY 6-4-5461-1X
1	1710	2.374-46	3.250	5.688	EY 6-4-5461X
1	1760	2.374-46	3.250	5.438	EY 6.3-4-101
1	1760	2.374-46	3.250	5.438	EY 6.3-4-101-1
1	1810	2.374-46	3.250	5.438	EY 6.5-4-2701

Pos	Series	Spline Data	Hub Dia	* to End of Hub	End Fitting Part Number
STDD (Continued)					
1	1810	2.374-46	3.250	5.438	EY 6.5-4-2701-1
1	1810	2.374-46	3.250	5.438	EY 6.5-4-2711-1X
1	1810	2.374-46	3.250	5.438	EY 6.5-4-2711X
2	1610	1.960-10	2.750	5.125	EY 5-4-5281X
2	1610	1.962-10	2.750	5.938	EY 5-4-5321X
2	1610	2.024-39	2.750	5.125	EY 5-4-6951X
2	1610	2.024-39	2.750	5.938	EY 5-4-6961X <i>High angle yoke</i>

2	1710	1.960-10	2.750	5.250	EY 6-4-4361X
2	1710	1.960-10	2.750	6.500	EY 6-4-4481X <i>High angle yoke</i>
2	1710	2.024-39	2.750	6.500	EY 6-4-6871X
2	1710	2.024-39	2.750	4.812	EY 6-4-6941X
2	1710	2.024-39	2.750	5.250	EY 6-4-6951X
2	1760	2.374-46	3.250	5.438	EY 6.3-4-211-1X
2	1760	2.374-46	3.250	5.438	EY 6.3-4-211X
2	1810	2.024-39	2.750	5.531	EY 6.5-4-3571X
3	1610	1.960-10	2.750	5.125	EY 5-4-5281X
3	1610	1.962-10	2.750	5.938	EY 5-4-5321X
3	1610	2.024-39	2.750	5.125	EY 5-4-6951X
3	1610	2.024-39	2.750	5.938	EY 5-4-6961X <i>High angle yoke</i>
3	1710	1.960-10	2.750	5.250	EY 6-4-4361X
3	1710	1.960-10	2.750	6.500	EY 6-4-4481X <i>High angle yoke</i>
3	1710	2.024-39	2.750	6.500	EY 6-4-6871X
3	1710	2.024-39	2.750	4.812	EY 6-4-6941X
3	1710	2.024-39	2.750	5.250	EY 6-4-6951X
3	1810	2.024-39	2.750	5.531	EY 6.5-4-3571X

STHD					
1	1710	2.250-10	3.000	6.062	EY 6-4-1991
1	1710	2.250-10	3.000	6.062	EY 6-4-1991-1
1	1710	2.250-10	3.000	6.062	EY 6-4-4411-1X
1	1710	2.374-46	3.250	5.688	EY 6-4-5461-1X
1	1710	2.374-46	3.250	5.688	EY 6-4-5461X
1	1760	2.374-46	3.250	5.438	EY 6.3-4-101-1
1	1810	2.374-46	3.250	5.438	EY 6.5-4-2701
1	1810	2.374-46	3.250	5.438	EY 6.5-4-2701-1
1	1810	2.374-46	3.250	5.438	EY 6.5-4-2711-1X
1	1810	2.374-46	3.250	5.438	EY 6.5-4-2711X
2	1610	1.960-10	2.750	5.125	EY 5-4-5281X
2	1610	1.962-10	2.750	5.938	EY 5-4-5321X
2	1610	2.024-39	2.750	5.125	EY 5-4-6951X
2	1610	2.024-39	2.750	5.938	EY 5-4-6961X <i>High angle yoke</i>
2	1710	1.960-10	2.750	5.250	EY 6-4-3221-1
2	1710	1.960-10	2.750	5.250	EY 6-4-4361X
2	1710	1.960-10	2.750	6.500	EY 6-4-4481X <i>High angle yoke</i>
2	1710	2.024-39	2.750	6.500	EY 6-4-5501-1 <i>High angle yoke</i>
2	1710	2.024-39	2.750	6.500	EY 6-4-6871-1X <i>High angle yoke</i>
2	1710	2.024-39	2.750	4.812	EY 6-4-6941X
2	1710	2.024-39	2.750	5.250	EY 6-4-6951X
2	1760	2.374-46	3.250	5.438	EY 6.3-4-211-1X
2	1760	2.374-46	3.250	5.438	EY 6.3-4-211X

Continued on next page

*C/L to End of Hub for EY (End Yoke); Flange Face to End of Hub for CF (Companion Flange)

■ Hub machined for speedometer gear



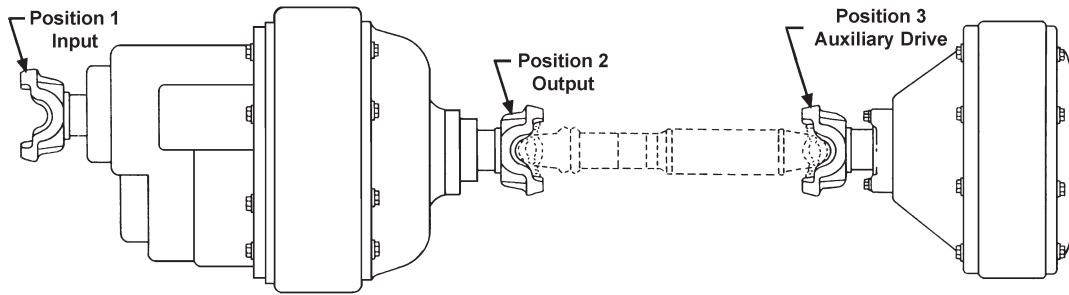

Pos	Series	Spline Data	Hub Dia	* to End of Hub	End Fitting Part Number
-----	--------	-------------	---------	-----------------	-------------------------

STHD (Continued)

2	1810	2.024-39	2.750	5.531	EY 6.5-4-3571X
3	1610	1.960-10	2.750	5.125	EY 5-4-5281X
3	1610	1.962-10	2.750	5.938	EY 5-4-5321X
3	1610	2.024-39	2.750	5.125	EY 5-4-6951X
3	1610	2.024-39	2.750	5.938	EY 5-4-6961X <i>High angle yoke</i>
3	1710	1.960-10	2.750	5.250	EY 6-4-3221
3	1710	1.960-10	2.750	5.250	EY 6-4-3221-1
3	1710	1.960-10	2.750	5.250	EY 6-4-4361X
3	1710	1.960-10	2.750	6.500	EY 6-4-4481X <i>High angle yoke</i>
3	1710	2.024-39	2.750	6.500	EY 6-4-5501-1 <i>High angle yoke</i>
3	1710	2.024-39	2.750	6.500	EY 6-4-6871-1X <i>High angle yoke</i>
3	1710	2.024-39	2.750	6.500	EY 6-4-6871X
3	1710	2.024-39	2.750	4.812	EY 6-4-6941X
3	1710	2.024-39	2.750	5.250	EY 6-4-6951X
3	1810	2.024-39	2.750	5.625	EY 6.5-4-3571-1X
3	1810	2.024-39	2.750	5.531	EY 6.5-4-3571X

STHF

1	1760	2.374-46	3.250	5.438	EY 6.3-4-101
1	1760	2.374-46	3.250	5.438	EY 6.3-4-101-1
1	1810	2.374-46	3.250	5.438	EY 6.5-4-2701
1	1810	2.374-46	3.250	5.438	EY 6.5-4-2701-1

SU-170

1	1710	2.374-46	3.250	5.938	EY 6-4-5961X
1	1760	2.374-46	3.250	5.625	EY 6.3-4-301-1X
1	1760	2.374-46	3.250	5.625	EY 6.3-4-301X
1	1810	2.374-46	3.250	5.688	EY 6.5-4-3221-1X
1	1810	2.374-46	3.250	5.688	EY 6.5-4-3221X
2	1610	2.024-39	3.000	5.531	EY 5-4-6271
2	1710	2.024-39	3.000	5.156	EY 6-4-6401
2	1710	2.024-39	3.000	5.156	EY 6-4-6401-1
2	1760	2.024-39	3.000	5.188	EY 6.3-4-531
2	1810	2.024-39	3.000	5.190	EY 6.5-4-3371
3	1610	2.250-10	3.000	5.625	EY 5-4-6891X
3	1710	2.250-10	3.000	6.062	EY 6-4-4411-1X
3	1710	2.250-10	3.000	6.062	EY 6-4-4411X
3	1710	2.250-10	3.000	7.188	EY 6-4-6891X <i>High angle yoke</i>
3	1760	2.250-10	3.000	5.844	EY 6.3-4-731-1X
3	1760	2.250-10	3.000	5.844	EY 6.3-4-731X
3	1810	2.250-10	3.000	5.844	EY 6.5-4-2551X

SU-270, SU-280

1	1760	2.374-46	3.250	5.625	EY 6.3-4-301-1X
1	1760	2.374-46	3.250	5.625	EY 6.3-4-301X

Pos	Series	Spline Data	Hub Dia	* to End of Hub	End Fitting Part Number
-----	--------	-------------	---------	-----------------	-------------------------

SU-270, SU-280 (Continued)

1	1810	2.374-46	3.250	5.688	EY 6.5-4-3221-1X
1	1810	2.374-46	3.250	5.688	EY 6.5-4-3221X
2	1610	2.024-39	3.000	5.531	EY 5-4-6271
2	1710	2.024-39	3.000	5.156	EY 6-4-6401
2	1710	2.024-39	3.000	5.156	EY 6-4-6401-1
2	1760	2.024-39	3.000	5.188	EY 6.3-4-531
2	1810	2.024-39	3.000	5.190	EY 6.5-4-3371
3	1710	2.024-39	3.000	6.250	EY 6-4-6381X <i>High angle yoke</i>
3	1710	2.024-39	3.000	6.250	EY 6-4-6391X <i>High angle yoke</i>
3	1810	2.024-39	3.000	5.190	EY 6.5-4-3381X

SUDD, SUHD

1	1710	2.250-10	3.000	6.062	EY 6-4-1991
1	1710	2.250-10	3.000	6.062	EY 6-4-1991-1
1	1710	2.250-10	3.000	6.062	EY 6-4-4411-1X
1	1710	2.374-46	3.250	5.688	EY 6-4-5461-1X
1	1710	2.374-46	3.250	5.688	EY 6-4-5461X
1	1760	2.374-46	3.250	5.438	EY 6.3-4-101
1	1760	2.374-46	3.250	5.438	EY 6.3-4-101-1
1	1810	2.374-46	3.250	5.438	EY 6.5-4-2701
1	1810	2.374-46	3.250	5.438	EY 6.5-4-2701-1
1	1810	2.374-46	3.250	5.438	EY 6.5-4-2711-1X
1	1810	2.374-46	3.250	5.438	EY 6.5-4-2711X
2	1610	1.960-10	2.750	5.125	EY 5-4-5281X
2	1610	1.962-10	2.750	5.938	EY 5-4-5321X
2	1610	2.024-39	2.750	5.125	EY 5-4-6951X
2	1610	2.024-39	2.750	5.938	EY 5-4-6961X <i>High angle yoke</i>
2	1710	1.960-10	2.750	5.250	EY 6-4-3221
2	1710	1.960-10	2.750	5.250	EY 6-4-3221-1
2	1710	1.960-10	2.750	5.250	EY 6-4-4361X
2	1710	1.960-10	2.750	6.500	EY 6-4-4481X <i>High angle yoke</i>
2	1710	2.024-39	2.750	6.500	EY 6-4-5501-1 <i>High angle yoke</i>
2	1710	2.024-39	2.750	6.500	EY 6-4-6871-1X <i>High angle yoke</i>
2	1710	2.024-39	2.750	6.500	EY 6-4-6871X
2	1710	2.024-39	2.750	4.812	EY 6-4-6941X
2	1710	2.024-39	2.750	5.250	EY 6-4-6951X
2	1760	2.374-46	3.250	5.438	EY 6.3-4-211-1X
2	1760	2.374-46	3.250	5.438	EY 6.3-4-211X
2	1810	2.024-39	2.750	5.531	EY 6.5-4-3571X
3	1610	1.960-10	2.750	5.125	EY 5-4-5281X
3	1610	1.962-10	2.750	5.938	EY 5-4-5321X
3	1610	2.024-39	2.750	5.125	EY 5-4-6951X
3	1610	2.024-39	2.750	5.938	EY 5-4-6961X <i>High angle yoke</i>

*C/L to End of Hub for EY (End Yoke); Flange Face to End of Hub for CF (Companion Flange)

■ Hub machined for speedometer gear



Pos	Series	Spline Data	Hub Dia	* to End of Hub	End Fitting Part Number
SUDD, SUHD (Continued)					
3	1710	1.960-10	2.750	5.250	EY 6-4-3221
3	1710	1.960-10	2.750	5.250	EY 6-4-3221-1
3	1710	1.960-10	2.750	5.250	EY 6-4-4361X
3	1710	1.960-10	2.750	6.500	EY 6-4-4481X <i>High angle yoke</i>
3	1710	2.024-39	2.750	6.500	EY 6-4-5501-1 <i>High angle yoke</i>
3	1710	2.024-39	2.750	6.500	EY 6-4-6871-1X <i>High angle yoke</i>
3	1710	2.024-39	2.750	6.500	EY 6-4-6871X
3	1710	2.024-39	2.750	4.812	EY 6-4-6941X
3	1710	2.024-39	2.750	5.250	EY 6-4-6951X
3	1810	2.024-39	2.750	5.625	EY 6.5-4-3571-1X
3	1810	2.024-39	2.750	5.531	EY 6.5-4-3571X

Pos	Series	Spline Data	Hub Dia	* to End of Hub	End Fitting Part Number
SUHF					
1	1760	2.374-46	3.250	5.438	EY 6.3-4-101
1	1760	2.374-46	3.250	5.438	EY 6.3-4-101-1
1	1810	2.374-46	3.250	5.438	EY 6.5-4-2701
1	1810	2.374-46	3.250	5.438	EY 6.5-4-2701-1

Pos	Series	Spline Data	Hub Dia	* to End of Hub	End Fitting Part Number
SW-170					
1	1710	2.374-46	3.250	5.938	EY 6-4-5961X
1	1760	2.374-46	3.250	5.625	EY 6.3-4-301-1X
1	1760	2.374-46	3.250	5.625	EY 6.3-4-301X
1	1810	2.374-46	3.250	5.688	EY 6.5-4-3221-1X
1	1810	2.374-46	3.250	5.688	EY 6.5-4-3221X
2	1610	2.024-39	3.000	5.531	EY 5-4-6271
2	1710	2.024-39	3.000	5.156	EY 6-4-6401
2	1710	2.024-39	3.000	5.156	EY 6-4-6401-1
2	1760	2.024-39	3.000	5.188	EY 6.3-4-531
2	1810	2.024-39	3.000	5.190	EY 6.5-4-3371
3	1610	2.250-10	3.000	5.625	EY 5-4-6891X
3	1710	2.250-10	3.000	6.062	EY 6-4-4411-1X
3	1710	2.250-10	3.000	6.062	EY 6-4-4411X
3	1710	2.250-10	3.000	7.188	EY 6-4-6891X <i>High angle yoke</i>
3	1760	2.250-10	3.000	5.844	EY 6.3-4-731-1X
3	1760	2.250-10	3.000	5.844	EY 6.3-4-731X
3	1810	2.250-10	3.000	5.844	EY 6.5-4-2551X

Pos	Series	Spline Data	Hub Dia	* to End of Hub	End Fitting Part Number
SW-270, SW-280					
1	1760	2.374-46	3.250	5.625	EY 6.3-4-301-1X
1	1760	2.374-46	3.250	5.625	EY 6.3-4-301X
1	1810	2.374-46	3.250	5.688	EY 6.5-4-3221-1X
1	1810	2.374-46	3.250	5.688	EY 6.5-4-3221X
2	1610	2.024-39	3.000	5.531	EY 5-4-6271
2	1710	2.024-39	3.000	5.156	EY 6-4-6401
2	1710	2.024-39	3.000	5.156	EY 6-4-6401-1
2	1760	2.024-39	3.000	5.188	EY 6.3-4-531
2	1810	2.024-39	3.000	5.190	EY 6.5-4-3371
3	1710	2.024-39	3.000	6.250	EY 6-4-6381X <i>High angle yoke</i>
3	1710	2.024-39	3.000	6.250	EY 6-4-6391X <i>High angle yoke</i>
3	1810	2.024-39	3.000	5.190	EY 6.5-4-3381X

*C/L to End of Hub for EY (End Yoke); Flange Face to End of Hub for CF (Companion Flange)

■ Hub machined for speedometer gear



Important: See Safety Information in General Information Section (J300P-GI)

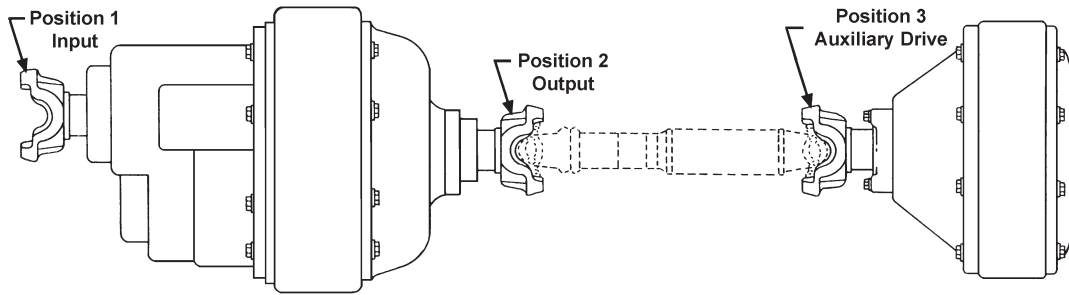

Pos	Series	Spline Data	Hub Dia	* to End of Hub	End Fitting Part Number
-----	--------	-------------	---------	-----------------	-------------------------

DSH40					
1	SPL170	2.274-44	3.000	5.270	EY 170-4-201-1X
1	SPL250	2.274-44	3.000	5.490	EY 250-4-81-1X
1	1610	2.274-44	3.000	5.000	EY 5-4-9261-1X
1	1710	2.274-44	3.000	5.190	EY 6-4-8451
1	1710	2.274-44	3.000	5.190	EY 6-4-8981-1X
1	1760	2.274-44	3.000	5.250	EY 6.3-4-5221-1X
1	1760	2.274-44	3.000	5.250	EY 6.3-4-5221X
1	1810	2.274-44	3.000	5.250	EY 6.5-4-4571-1X
1	1810	2.274-44	3.000	5.250	EY 6.5-4-4571X
2	SPL170	2.024-39	2.625	5.266	EY 170-4-221-1X
2	SPL170	2.024-39	2.625	6.500	EY 170-4-241-1X <i>High angle yoke</i>
2	1610	2.024-39	2.625	6.000	EY 5-4-9271X <i>High angle yoke</i>
2	1710	2.024-39	2.625	6.125	EY 6-4-9001-1X
2	1710	2.024-39	2.625	6.125	EY 6-4-9001X
2	1710	2.024-39	2.625	5.250	EY 6-4-9041-1X
2	1710	2.024-39	2.625	5.250	EY 6-4-9041X
3	SPL170	2.024-39	3.000	5.156	EY 170-4-261-1X
3	SPL170	2.024-39	3.000	6.240	EY 170-4-281-1X <i>High angle yoke</i>
3	SPL90	2.024-39	3.000	4.750	EY 90-4-251-1X
3	1610	2.024-39	3.000	4.875	EY 5-4-9231-1X
3	1610	2.024-39	3.000	6.000	EY 5-4-9241-1X <i>High angle yoke</i>
3	1610	2.024-39	3.000	6.000	EY 5-4-9241X <i>High angle yoke</i>
3	1710	2.024-39	3.000	6.125	EY 6-4-8991-1X <i>High angle yoke</i>
3	1710	2.024-39	3.000	6.125	EY 6-4-8991X <i>High angle yoke</i>
3	1710	2.024-39	3.000	5.250	EY 6-4-9031-1X
3	1710	2.024-39	3.000	5.250	EY 6-4-9031X

DSH44					
1	SPL170	2.274-44	3.000	5.270	EY 170-4-201-1X
1	SPL250	2.274-44	3.000	5.490	EY 250-4-81-1X
1	1610	2.274-44	3.000	5.000	EY 5-4-9261-1X
1	1710	2.274-44	3.000	5.190	EY 6-4-8451
1	1710	2.274-44	3.000	5.190	EY 6-4-8981-1X
1	1760	2.274-44	3.000	5.250	EY 6.3-4-5221-1X
1	1760	2.274-44	3.000	5.250	EY 6.3-4-5221X
1	1810	2.274-44	3.000	5.250	EY 6.5-4-4571-1X
1	1810	2.274-44	3.000	5.250	EY 6.5-4-4571X
2	SPL170	2.024-39	2.625	5.266	EY 170-4-221-1X
2	SPL170	2.024-39	2.625	6.500	EY 170-4-241-1X <i>High angle yoke</i>
2	1610	2.024-39	2.625	6.000	EY 5-4-9271X <i>High angle yoke</i>
2	1710	2.024-39	2.625	6.125	EY 6-4-9001-1X

Pos	Series	Spline Data	Hub Dia	* to End of Hub	End Fitting Part Number
-----	--------	-------------	---------	-----------------	-------------------------

DSH44 (Continued)					
2	1710	2.024-39	2.625	6.125	EY 6-4-9001X
2	1710	2.024-39	2.625	5.250	EY 6-4-9041-1X
2	1710	2.024-39	2.625	5.250	EY 6-4-9041X
3	SPL170	2.024-39	3.000	5.156	EY 170-4-261-1X
3	SPL170	2.024-39	3.000	6.240	EY 170-4-281-1X <i>High angle yoke</i>
3	1610	2.024-39	3.000	6.000	EY 5-4-9241X <i>High angle yoke</i>
3	1710	2.024-39	3.000	6.125	EY 6-4-8991-1X <i>High angle yoke</i>
3	1710	2.024-39	3.000	6.125	EY 6-4-8991X <i>High angle yoke</i>
3	1710	2.024-39	3.000	5.250	EY 6-4-9031-1X
3	1710	2.024-39	3.000	5.250	EY 6-4-9031X

DSP40					
1	SPL170	2.274-44	3.000	5.270	EY 170-4-201-1X
1	SPL250	2.274-44	3.000	5.490	EY 250-4-81-1X
1	1610	2.274-44	3.000	5.000	EY 5-4-9261-1X
1	1710	2.274-44	3.000	5.190	EY 6-4-8981-1X
1	1760	2.274-44	3.000	5.250	EY 6.3-4-5221-1X
1	1760	2.274-44	3.000	5.250	EY 6.3-4-5221X
1	1810	2.274-44	3.000	5.250	EY 6.5-4-4571-1X
1	1810	2.274-44	3.000	5.250	EY 6.5-4-4571X
2	SPL170	2.024-39	2.625	5.266	EY 170-4-221-1X
2	SPL170	2.024-39	2.625	6.500	EY 170-4-241-1X <i>High angle yoke</i>
2	1610	2.024-39	2.625	6.000	EY 5-4-9271X <i>High angle yoke</i>
2	1710	2.024-39	2.625	6.125	EY 6-4-9001-1X
2	1710	2.024-39	2.625	6.125	EY 6-4-9001X
2	1710	2.024-39	2.625	5.250	EY 6-4-9041-1X
2	1710	2.024-39	2.625	5.250	EY 6-4-9041X
3	SPL170	2.024-39	3.000	5.156	EY 170-4-261-1X
3	SPL170	2.024-39	3.000	6.240	EY 170-4-281-1X <i>High angle yoke</i>
3	SPL90	2.024-39	3.000	4.750	EY 90-4-251-1X
3	1480	2.024-39	3.000	4.344	EY 3-4-13081-1X
3	1550	2.024-39	3.000	4.281	EY 4-4-7571-1X
3	1610	2.024-39	3.000	4.875	EY 5-4-9231-1X
3	1610	2.024-39	3.000	6.000	EY 5-4-9241-1X <i>High angle yoke</i>
3	1710	2.024-39	3.000	6.125	EY 6-4-8991-1X <i>High angle yoke</i>
3	1710	2.024-39	3.000	6.125	EY 6-4-8991X <i>High angle yoke</i>
3	1710	2.024-39	3.000	5.250	EY 6-4-9031-1X
3	1710	2.024-39	3.000	5.250	EY 6-4-9031X

*C/L to End of Hub for EY (End Yoke); Flange Face to End of Hub for CF (Companion Flange)

■ Hub machined for speedometer gear



Pos	Series	Spline Data	Hub Dia	* to End of Hub	End Fitting Part Number
DSP41					
1	SPL170	2.274-44	3.000	5.270	EY 170-4-201-1X
1	SPL250	2.274-44	3.000	5.490	EY 250-4-81-1X
1	1610	2.274-44	3.000	5.000	EY 5-4-9261-1X
1	1710	2.274-44	3.000	5.190	EY 6-4-8981-1X
1	1760	2.274-44	3.000	5.250	EY 6.3-4-5221-1X
1	1760	2.274-44	3.000	5.250	EY 6.3-4-5221X
1	1810	2.274-44	3.000	5.250	EY 6.5-4-4571-1X
1	1810	2.274-44	3.000	5.250	EY 6.5-4-4571X
2	SPL170	2.024-39	2.625	5.266	EY 170-4-221-1X
2	SPL170	2.024-39	2.625	6.500	EY 170-4-241-1X <i>High angle yoke</i>
2	1610	2.024-39	2.625	6.000	EY 5-4-9271X <i>High angle yoke</i>
2	1710	2.024-39	2.625	6.125	EY 6-4-9001-1X
2	1710	2.024-39	2.625	6.125	EY 6-4-9001X
2	1710	2.024-39	2.625	5.250	EY 6-4-9041-1X
2	1710	2.024-39	2.625	5.250	EY 6-4-9041X
3	SPL170	2.024-39	3.000	6.240	EY 170-4-281-1X <i>High angle yoke</i>
3	1480	2.024-39	3.000	4.344	EY 3-4-13081-1X
3	1550	2.024-39	3.000	4.281	EY 4-4-7571-1X
3	1610	2.024-39	3.000	4.875	EY 5-4-9231-1X
3	1610	2.024-39	3.000	6.000	EY 5-4-9241-1X <i>High angle yoke</i>
3	1710	2.024-39	3.000	6.125	EY 6-4-8991-1X <i>High angle yoke</i>
3	1710	2.024-39	3.000	6.125	EY 6-4-8991X <i>High angle yoke</i>
3	1710	2.024-39	3.000	5.250	EY 6-4-9031-1X
3	1710	2.024-39	3.000	5.250	EY 6-4-9031X

Pos	Series	Spline Data	Hub Dia	* to End of Hub	End Fitting Part Number
DST40					
1	SPL140	2.274-44	3.000	5.160	EY 140-4-1271-1X
1	SPL140	2.274-44	3.000	5.160	EY 140-4-331-1X
1	SPL170	2.274-44	3.000	5.270	EY 170-4-1671-1X <i>Counterbore at hub end.</i>
1	SPL170	2.274-44	3.000	5.270	EY 170-4-201-1X
1	SPL250	2.274-44	3.000	5.490	EY 250-4-81-1X
1	1610	2.274-44	3.000	5.000	EY 5-4-9261-1X
1	1710	2.274-44	3.000	5.190	EY 6-4-8981-1X
1	1760	2.274-44	3.000	5.250	EY 6.3-4-5221-1X
1	1760	2.274-44	3.000	5.250	EY 6.3-4-5221X
1	1810	2.274-44	3.000	5.250	EY 6.5-4-4571-1X
1	1810	2.274-44	3.000	5.250	EY 6.5-4-4571X
2	SPL170	2.024-39	2.625	5.750	EY 170-4-08578-1X
2	SPL170	2.024-39	2.625	5.266	EY 170-4-221-1X
2	SPL170	2.024-39	2.625	6.500	EY 170-4-241-1X <i>High angle yoke</i>
2	1610	2.024-39	2.625	6.000	EY 5-4-9271X <i>High angle yoke</i>
2	1710	2.024-39	2.625	6.125	EY 6-4-9001-1X
2	1710	2.024-39	2.625	6.125	EY 6-4-9001X
2	1710	2.024-39	2.625	5.250	EY 6-4-9041-1X
2	1710	2.024-39	2.625	5.250	EY 6-4-9041X
3	SPL140	2.024-39	3.000	4.940	EY 140-4-1161-1X
3	SPL140	2.274-44	3.000	5.160	EY 140-4-331-1X
3	SPL140	2.024-39	3.000	4.940	EY 140-4-371-1X
3	SPL170	2.024-39	3.000	5.540	EY 170-4-08577-1X
3	SPL170	2.024-39	3.000	6.240	EY 170-4-1631-1X
3	SPL170	2.274-44	3.000	5.270	EY 170-4-201-1X
3	SPL170	2.024-39	3.000	5.156	EY 170-4-261-1X
3	SPL170	2.024-39	3.000	6.240	EY 170-4-281-1X <i>High angle yoke</i>

Pos	Series	Spline Data	Hub Dia	* to End of Hub	End Fitting Part Number
DST40 (Continued)					
3	1610	2.024-39	3.000	6.000	EY 5-4-8261 <i>High angle yoke</i>
3	1610	2.024-39	3.000	6.000	EY 5-4-8261-1 <i>High angle yoke</i>
3	1610	2.024-39	3.000	6.000	EY 5-4-9241-1X <i>High angle yoke</i>
3	1710	2.024-39	3.000	6.125	EY 6-4-8991-1X <i>High angle yoke</i>
3	1710	2.024-39	3.000	6.125	EY 6-4-8991X <i>High angle yoke</i>
3	1710	2.024-39	3.000	5.250	EY 6-4-9031-1X
3	1710	2.024-39	3.000	5.250	EY 6-4-9031X
3	1760	2.274-44	3.000	5.250	EY 6.3-4-5221-1X
3	1760	2.274-44	3.000	5.250	EY 6.3-4-5221X

Pos	Series	Spline Data	Hub Dia	* to End of Hub	End Fitting Part Number
DST41					
1	SPL170	2.274-44	3.000	5.270	EY 170-4-201-1X
1	SPL250	2.274-44	3.000	5.490	EY 250-4-81-1X
1	1610	2.274-44	3.000	5.000	EY 5-4-9261-1X
1	1710	2.274-44	3.000	5.190	EY 6-4-8981-1X
1	1760	2.274-44	3.000	5.250	EY 6.3-4-5221-1X
1	1760	2.274-44	3.000	5.250	EY 6.3-4-5221X
1	1810	2.274-44	3.000	5.250	EY 6.5-4-4571-1X
1	1810	2.274-44	3.000	5.250	EY 6.5-4-4571X
2	SPL170	2.024-39	2.625	5.266	EY 170-4-221-1X
2	SPL170	2.024-39	2.625	6.500	EY 170-4-241-1X <i>High angle yoke</i>
2	1610	2.024-39	2.625	6.000	EY 5-4-9271X <i>High angle yoke</i>
2	1710	2.024-39	2.625	6.125	EY 6-4-9001-1X
2	1710	2.024-39	2.625	6.125	EY 6-4-9001X
2	1710	2.024-39	2.625	5.250	EY 6-4-9041-1X
2	1710	2.024-39	2.625	5.250	EY 6-4-9041X
3	SPL170	2.024-39	3.000	5.156	EY 170-4-261-1X
3	SPL170	2.024-39	3.000	6.240	EY 170-4-281-1X <i>High angle yoke</i>
3	1610	2.024-39	3.000	6.000	EY 5-4-9241-1X <i>High angle yoke</i>
3	1710	2.024-39	3.000	6.125	EY 6-4-8991-1X <i>High angle yoke</i>
3	1710	2.024-39	3.000	6.125	EY 6-4-8991X <i>High angle yoke</i>
3	1710	2.024-39	3.000	5.250	EY 6-4-9031-1X
3	1710	2.024-39	3.000	5.250	EY 6-4-9031X

Pos	Series	Spline Data	Hub Dia	* to End of Hub	End Fitting Part Number
D145					
1	SPL140	2.274-44	3.000	5.160	EY 140-4-1271-1X
1	SPL140	2.274-44	3.000	5.160	EY 140-4-331-1X
1	SPL170	2.274-44	3.000	5.270	EY 170-4-1671-1X <i>Counterbore at hub end.</i>
1	SPL170	2.274-44	3.000	5.270	EY 170-4-201-1X
1	SPL250	2.274-44	3.000	5.490	EY 250-4-81-1X
1	1610	2.274-44	3.000	5.000	EY 5-4-9261-1X
1	1710	2.274-44	3.000	5.190	EY 6-4-8451
1	1710	2.274-44	3.000	5.190	EY 6-4-8451-1
1	1710	2.274-44	3.000	5.190	EY 6-4-8981-1X
1	1710	2.274-44	3.000	5.190	EY 6-4-8981X
1	1760	2.274-44	3.000	5.250	EY 6.3-4-5221-1X
1	1760	2.274-44	3.000	5.250	EY 6.3-4-5221X
1	1810	2.274-44	3.000	5.250	EY 6.5-4-4571-1X
1	1810	2.274-44	3.000	5.250	EY 6.5-4-4571X
2	SPL170	2.024-39	2.625	5.750	EY 170-4-08578-1X
2	SPL170	2.024-39	2.625	6.500	EY 170-4-1651-1X

Continued on next page

*C/L to End of Hub for EY (End Yoke); Flange Face to End of Hub for CF (Companion Flange)

■ Hub machined for speedometer gear



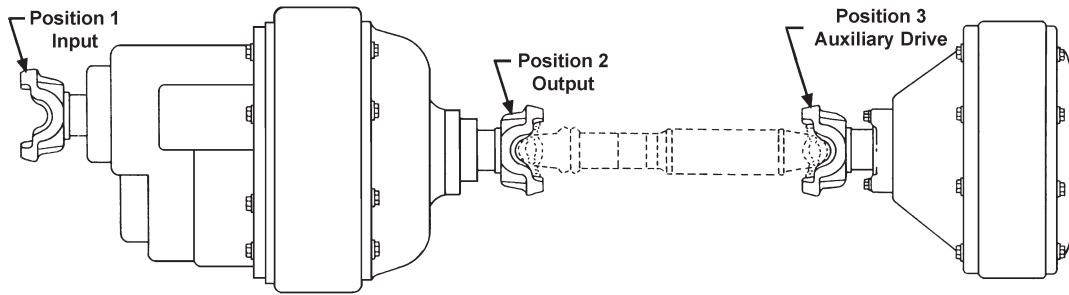

Pos	Series	Spline Data	Hub Dia	* to End of Hub	End Fitting Part Number
-----	--------	-------------	---------	-----------------	-------------------------

D145 (Continued)

2	SPL170	2.024-39	2.625	5.266	EY 170-4-221-1X
2	SPL170	2.024-39	2.625	6.500	EY 170-4-241-1X <i>High angle yoke</i>
2	1610	2.024-39	2.625	6.000	EY 5-4-9271X <i>High angle yoke</i>
2	1710	2.024-39	2.625	6.125	EY 6-4-8431
2	1710	2.024-39	2.625	6.125	EY 6-4-8431-1
2	1710	2.024-39	2.625	5.250	EY 6-4-8441
2	1710	2.024-39	2.625	5.250	EY 6-4-8441-1
2	1710	2.024-39	2.625	6.125	EY 6-4-9001-1X
2	1710	2.024-39	2.625	6.125	EY 6-4-9001X
2	1710	2.024-39	2.625	5.250	EY 6-4-9041-1X
2	1710	2.024-39	2.625	5.250	EY 6-4-9041X
3	SPL170	2.024-39	3.000	5.156	EY 170-4-1991-1X <i>High angle yoke</i>
3	SPL170	2.024-39	3.000	6.240	EY 170-4-2001-1X <i>High angle yoke</i>
3	1710	2.024-39	3.000	5.250	EY 6-4-10321-1X
3	1710	2.024-39	3.000	6.125	EY 6-4-10401-1X <i>High angle yoke</i>

D155

1	SPL250	2.544-49	3.861	6.200	EY 250-4-1291-1X
1	SPL350	2.544-49	3.896	6.200	EY 350-4-201-1X
2	SPL170	2.143-41	2.938	5.799	EY 170-4-10002594-1X
2	SPL170	2.143-41	2.938	7.190	EY 170-4-10002595-1X
2	SPL250	2.143-41	2.938	6.251	EY 250-4-10002596-1X
2	SPL250	2.143-41	2.938	7.110	EY 250-4-10002597-1X
3	SPL170	2.544-49	3.820	5.531	EY 170-4-2021-1X
3	SPL170	2.544-49	3.818	6.260	EY 170-4-2031-1X
3	SPL250	2.544-49	3.861	5.830	EY 250-4-1301-1X
3	SPL250	2.544-49	3.812	6.750	EY 250-4-1311-1X <i>Counterbore at hub end.</i>

D156

1	SPL170	2.274-44	3.000	5.270	EY 170-4-2011-1X
1	SPL250	2.274-44	3.000	5.490	EY 250-4-1281-1X
2	SPL170	2.024-39	2.625	5.270	EY 170-4-10002590-1X
2	SPL170	2.024-39	2.625	6.500	EY 170-4-10002591-1X
3	SPL170	2.544-49	3.820	5.531	EY 170-4-2021-1X
3	SPL170	2.544-49	3.818	6.260	EY 170-4-2031-1X

D170, D190

1	SPL170	2.544-49	3.820	6.040	EY 170-4-08444-1X <i>132863K = 170-4-08444-1X & nut# 131095; Spicer axles only</i>
1	SPL170	2.544-49	3.820	6.810	EY 170-4-08461-1X <i>132931K = 170-4-08461-1X & nut# 131095; Spicer axles only</i>
1	SPL250	2.544-49	3.819	6.200	EY 131446K <i>Attach nut #131095 on Spicer Axle only</i>
1	SPL250	2.544-49	3.819	6.200	EY 250-4-08445-1X <i>131446K = 250-4-08445-1X & nut# 131095; Spicer axles only</i>
1	SPL250	2.544-49	3.861	6.200	EY 250-4-1291-1X
1	SPL250	2.544-49	3.861	6.200	EY 250-4-134705-1X

Pos	Series	Spline Data	Hub Dia	* to End of Hub	End Fitting Part Number
-----	--------	-------------	---------	-----------------	-------------------------

D170, D190 (Continued)

1	SPL350	2.544-49	3.896	6.200	EY 350-4-201-1X
1	SPL350	2.544-49	3.820	6.200	EY 350-4-31-1X
1	1710	2.544-49	3.819	6.050	EY 131519K <i>Attach nut #131095 on Spicer Axle only</i>
1	1710	2.544-49	3.819	6.050	EY 6-4-08438X <i>131530K = 6-4-08438X & nut# 131095; Spicer axles only</i>
1	1710	2.544-49	3.819	6.050	EY 6-4-08439-1X
1	1710	2.143-41	2.938	6.620	EY 6-4-08447-1X <i>131450K = 6-4-08447-1X & nut# 128049; Spicer axles only</i>
1	1710	2.544-49	3.819	6.260	EY 6-4-08449X <i>131439K = 6-4-08449X & nut# 131095; Spicer axles only</i>
1	1710	2.544-49	3.819	6.260	EY 6-4-08450-1X <i>131438K = 6-4-08450-1X & nut# 131095; Spicer axles only</i>
1	1760	2.544-49	3.819	6.050	EY 131520K <i>Attach nut #131095 on Spicer Axle only</i>
1	1760	2.544-49	3.819	6.050	EY 131530K <i>Attach nut #131095 on Spicer Axle only</i>
1	1760	2.544-49	3.819	5.750	EY 6.3-4-05582-1 <i>131482K = 5008441 yoke assy & nut# 131095; Spicer axles only</i>
1	1760	2.544-49	3.819	5.750	EY 6.3-4-08441-1X <i>131520K = 6.3-4-08441-1X & nut# 131095; Spicer axles only</i>
1	1810	2.544-49	3.820	5.740	EY 131447K <i>Attach nut #131095 on Spicer Axle only</i>
1	1810	2.544-49	3.819	5.740	EY 131448K <i>Attach nut #131095 on Spicer Axle only</i>
1	1810	2.544-49	3.819	5.740	EY 6.5-4-08442X <i>131448K = 6.5-4-08442X & nut# 131095; Spicer axles only</i>
1	1810	2.544-49	3.820	5.740	EY 6.5-4-08443-1X <i>131447K = 6.5-4-08443-1X & nut# 131095; Spicer axles only</i>
1	1810	2.544-49	3.818	5.740	EY 6.5-4-08457-1X <i>131443K = 6.5-4-08457-1X & nut# 131095; Spicer axles only</i>
1	1810	2.544-49	3.818	5.740	EY 6.5-4-5091 <i>131444K = 6.5-4-08456X & nut# 131095; Spicer axles only</i>
2	SPL170	2.143-41	2.938	7.190	EY 131451K <i>Attach nut #128049 for Spicer Axles only</i>
2	SPL170	2.143-41	2.938	7.190	EY 170-4-08448-1X <i>131451K = 170-4-08448-1X & nut# 128049; Spicer axles only</i>
2	1710	2.143-41	2.938	6.620	EY 131449K <i>Attach nut #128049 for Spicer Axles only</i>
2	1710	2.143-41	2.938	6.620	EY 131450K <i>Attach nut #128049 for Spicer Axles only</i>
2	1710	2.544-49	3.819	6.200	EY 6-4-08446X <i>131449K = 6-4-08446X & nut# 128049; Spicer axles only</i>
2	1710	2.143-41	2.938	6.620	EY 6-4-08447-1X <i>131450K = 6-4-08447-1X & nut# 128049; Spicer axles only</i>
2	1710	2.544-49	3.819	6.260	EY 6-4-08449X <i>131439K = 6-4-08449X & nut# 131095; Spicer axles only</i>
2	1710	2.544-49	3.819	6.260	EY 6-4-08450-1X <i>131438K = 6-4-08450-1X & nut# 131095; Spicer axles only</i>
2	1710	2.143-41	2.938	6.620	EY 6-4-10301 <i>131449K = 6-4-08446X & nut# 128049; Spicer axles only</i>
					<i>High angle yoke</i>

*C/L to End of Hub for EY (End Yoke); Flange Face to End of Hub for CF (Companion Flange)

■ Hub machined for speedometer gear



Pos	Series	Spline Data	Hub Dia	* to End of Hub	End Fitting Part Number
D170, D190 (Continued)					
2	1710	2.143-41	2.938	6.620	EY 6-4-10301-1 <i>131450K = 6-4-08447-1X & nut# 128049; Spicer axles only</i>
3	SPL170	2.544-49	3.818	5.531	EY 131433K <i>Attach nut #131095 on Spicer Axle only</i>
3	SPL170	2.544-49	3.818	6.260	EY 131434K <i>Attach nut #131095 on Spicer Axle only</i>
3	SPL170	2.544-49	3.819	5.830	EY 131435K <i>Attach nut #131095 on Spicer Axle only</i>
3	SPL170	2.544-49	3.818	6.260	EY 170-4-08451-1X <i>131434K = 170-4-08451-1X & nut# 131095; Spicer axles only</i>
3	SPL170	2.544-49	3.820	5.531	EY 170-4-08458-1X <i>131433K = 170-4-08458-1X & nut# 131095; Spicer axles only</i>
3	SPL170	2.544-49	3.820	5.531	EY 170-4-2021-1X
3	SPL170	2.544-49	3.818	6.260	EY 170-4-2031-1X
3	1710	2.544-49	3.819	6.260	EY 131438K <i>Attach nut #131095 on Spicer Axle only</i>
3	1710	2.544-49	3.819	6.260	EY 131439K <i>Attach nut #131095 on Spicer Axle only</i>
3	1710	2.544-49	3.819	5.570	EY 131442K <i>Attach nut #131095 on Spicer Axle only</i>
3	1710	2.544-49	3.819	6.260	EY 6-4-08449X <i>131439K = 6-4-08449X & nut# 131095; Spicer axles only</i>
3	1710	2.544-49	3.819	6.260	EY 6-4-08450-1X <i>131438K = 6-4-08450-1X & nut# 131095; Spicer axles only</i>
3	1710	2.544-49	3.819	5.570	EY 6-4-08452X <i>131442K = 6-4-08452X & nut# 131095; Spicer axles only</i>
3	1710	2.544-49	3.819	5.570	EY 6-4-08453-1X <i>131437K = 6-4-08453-1X & nut 131095; Spicer axles only</i>
3	1710	2.544-49	3.819	6.260	EY 6-4-10311 <i>131439K = 6-4-08449X & nut# 131095; Spicer axles only</i>
3	1710	2.544-49	3.819	6.260	EY 6-4-10311-1 <i>131438K = 6-4-08450-1X & nut# 131095; Spicer axles only</i>
3	1760	2.544-49	3.818	5.200	EY 131440K <i>Attach nut #131095 on Spicer Axle only</i>
3	1760	2.544-49	3.818	5.200	EY 131441K <i>Attach nut #131095 on Spicer Axle only</i>
3	1810	2.544-49	3.818	5.740	EY 131443K <i>Attach nut #131095 on Spicer Axle only</i>
3	1810	2.544-49	3.818	5.740	EY 131444K <i>Attach nut #131095 on Spicer Axle only</i>

D590					
1	SPL170	2.544-49	3.820	6.040	EY 170-4-08444-1X <i>132863K = 170-4-08444-1X & nut# 131095; Spicer axles only</i>
1	SPL170	2.544-49	3.820	6.810	EY 170-4-08461-1X <i>132931K = 170-4-08461-1X & nut# 131095; Spicer axles only</i>
1	SPL250	2.544-49	3.819	6.200	EY 250-4-08445-1X <i>131446K = 250-4-08445-1X & nut# 131095; Spicer axles only</i>
1	1710	2.544-49	3.819	6.050	EY 6-4-08438X <i>131530K = 6-4-08438X & nut# 131095; Spicer axles only</i>
1	1810	2.544-49	3.819	5.740	EY 6.5-4-08442X <i>131448K = 6.5-4-08442X & nut# 131095; Spicer axles only</i>
1	1810	2.544-49	3.820	5.740	EY 6.5-4-08443-1X <i>131447K = 6.5-4-08443-1X & nut# 131095; Spicer axles only</i>
2	SPL170	2.143-41	2.938	7.190	EY 170-4-08448-1X <i>131451K = 170-4-08448-1X & nut# 128049; Spicer axles only</i> <i>High angle yoke</i>
2	1710	2.544-49	3.819	6.200	EY 6-4-08446X <i>131449K = 6-4-08446X & nut# 128049; Spicer axles only</i>
2	1710	2.143-41	2.938	6.620	EY 6-4-08447-1X <i>131450K = 6-4-08447-1X & nut# 128049; Spicer axles only</i>
3	SPL170	2.544-49	3.820	6.040	EY 170-4-08444-1X <i>132863K = 170-4-08444-1X & nut# 131095; Spicer axles only</i>
3	SPL170	2.544-49	3.820	6.810	EY 170-4-08461-1X <i>132931K = 170-4-08461-1X & nut# 131095; Spicer axles only</i>
3	1710	2.544-49	3.819	6.050	EY 6-4-08438X <i>131530K = 6-4-08438X & nut# 131095; Spicer axles only</i>

Pos	Series	Spline Data	Hub Dia	* to End of Hub	End Fitting Part Number
G340-S, G380-S					
1	1610	2.114-32	3.000	5.375	EY 5-4-7221X
3	1610	2.114-32	3.000	5.375	EY 5-4-7221X
3	1610	2.114-32	3.000	5.375	EY 5-4-8611-1X
3	1610	2.114-32	3.000	6.000	EY 5-4-8691-1X <i>High angle yoke</i>
3	1710	2.114-32	3.000	6.062	EY 6-4-8761-1X <i>High angle yoke</i>
G400-S					
1	1610	2.364-36	3.000	5.156	EY 5-4-8651-1X
1	1710	2.364-36	3.000	5.438	EY 6-4-8721-1X
1	1760	2.364-36	3.000	5.438	EY 6.3-4-1561-1X
1	1810	2.364-36	3.000	5.438	EY 6.5-4-4441-1X
2	1610	1.989-30	3.000	6.000	EY 5-4-8661-1 <i>High angle yoke</i>
2	1710	1.989-30	3.000	6.281	EY 6-4-8731-1 <i>High angle yoke</i>
3	1610	2.114-32	3.000	6.000	EY 5-4-8691-1X <i>High angle yoke</i>
3	1710	2.114-32	3.000	6.062	EY 6-4-8761-1X <i>High angle yoke</i>
G401-S					
1	1610	2.114-32	3.000	5.375	EY 5-4-7221X
3	1610	2.114-32	3.000	5.375	EY 5-4-7221X
J340-S, J380-S					
1	1610	2.114-32	3.000	5.375	EY 5-4-7221X
1	1610	2.364-36	3.000	5.156	EY 5-4-8651-1X
1	1710	2.364-36	3.000	5.438	EY 6-4-8721-1X
1	1760	2.364-36	3.000	5.438	EY 6.3-4-1551-1
1	1760	2.364-36	3.000	5.438	EY 6.3-4-1561-1X
1	1810	2.364-36	3.000	5.438	EY 6.5-4-4441-1X
2	1610	1.989-30	3.000	6.000	EY 5-4-8661-1 <i>High angle yoke</i>
2	1710	1.989-30	3.000	6.281	EY 6-4-8731-1 <i>High angle yoke</i>
3	1610	2.114-32	3.000	5.375	EY 5-4-7221X
3	1610	2.114-32	3.000	5.375	EY 5-4-8611-1X
3	1610	2.114-32	3.000	6.000	EY 5-4-8691-1X <i>High angle yoke</i>
3	1710	2.114-32	3.000	6.062	EY 6-4-8761-1X <i>High angle yoke</i>
J400-S					
1	SPL250	2.364-36	3.000	5.680	EY 250-4-361-1
1	SPL250	2.364-36	3.000	5.680	EY 250-4-371-1X
1	1610	2.364-36	3.000	5.156	EY 5-4-8641-1
1	1610	2.364-36	3.000	5.156	EY 5-4-8651-1X
1	1710	2.364-36	3.000	5.438	EY 6-4-8711-1
1	1710	2.364-36	3.000	5.438	EY 6-4-8721-1X
1	1760	2.364-36	3.000	5.438	EY 6.3-4-1551-1
1	1760	2.364-36	3.000	5.438	EY 6.3-4-1561-1X
1	1810	2.364-36	3.000	5.438	EY 6.5-4-4431-1
1	1810	2.364-36	3.000	5.438	EY 6.5-4-4441-1X
2	SPL170	1.989-30	3.000	6.580	EY 170-4-771-1 <i>High angle yoke</i>
2	1610	1.989-30	3.000	6.000	EY 5-4-8661-1 <i>High angle yoke</i>
2	1610	1.989-30	3.000	6.000	EY 5-4-8671-1X <i>High angle yoke</i>
2	1710	1.989-30	3.000	6.281	EY 6-4-8731-1 <i>High angle yoke</i>

Continued on next page

*C/L to End of Hub for EY (End Yoke); Flange Face to End of Hub for CF (Companion Flange)

■ Hub machined for speedometer gear



Important: See Safety Information in General Information Section (J300P-GI)

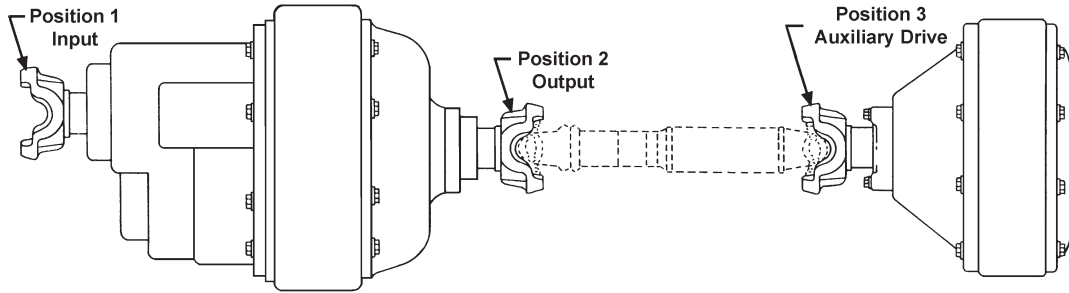

Pos	Series	Spline Data	Hub Dia	* to End of Hub	End Fitting Part Number
-----	--------	-------------	---------	-----------------	-------------------------

J400-S (Continued)

3	1610	2.114-32	3.000	2.844	CF 5-1-6691 .424 deep counterbore at hub end
3	1610	2.114-32	3.000	2.844	CF 5-1-6701X .424 deep counterbore at hub end
3	SPL140	2.114-32	3.000	4.810	EY 140-4-921-1
3	SPL140	2.114-32	3.000	4.810	EY 140-4-931-1X
3	SPL170	2.114-32	3.000	5.000	EY 170-4-891-1
3	SPL170	2.114-32	3.000	5.000	EY 170-4-901-1X
3	SPL170	2.114-32	3.000	6.312	EY 170-4-951-1 High angle yoke
3	SPL170	2.114-32	3.000	6.312	EY 170-4-961-1X High angle yoke
3	SPL250	2.114-32	3.000	5.240	EY 250-4-411-1
3	SPL250	2.114-32	3.000	5.240	EY 250-4-421-1X
3	SPL90	2.114-32	3.000	4.375	EY 90-4-581-1
3	SPL90	2.114-32	3.000	4.375	EY 90-4-591-1X
3	1480	2.114-32	3.000	4.281	EY 3-4-13341-1
3	1480	2.114-32	3.000	4.281	EY 3-4-13351-1X
3	1550	2.114-32	3.000	4.312	EY 4-4-6991-1
3	1550	2.114-32	3.000	4.312	EY 4-4-7001-1X
3	1610	2.114-32	3.000	5.375	EY 5-4-8601-1
3	1610	2.114-32	3.000	5.375	EY 5-4-8611-1X
3	1610	2.114-32	3.000	6.000	EY 5-4-8681-1 High angle yoke
3	1610	2.114-32	3.000	6.000	EY 5-4-8691-1X High angle yoke
3	1710	2.114-32	3.000	4.562	EY 6-4-8671-1
3	1710	2.114-32	3.000	4.562	EY 6-4-8681-1X
3	1710	2.114-32	3.000	6.062	EY 6-4-8751-1 High angle yoke
3	1710	2.114-32	3.000	6.062	EY 6-4-8761-1X High angle yoke
3	1760	2.114-32	3.000	5.000	EY 6.3-4-1511-1
3	1760	2.114-32	3.000	5.000	EY 6.3-4-1521-1X
3	1810	2.114-32	3.000	5.000	EY 6.5-4-4451-1
3	1810	2.114-32	3.000	5.000	EY 6.5-4-4461-1X

M460-S

1	1610	2.364-36	3.000	5.156	EY 5-4-8651-1X
1	1710	2.364-36	3.000	5.438	EY 6-4-8721-1X
1	1760	2.364-36	3.000	5.438	EY 6.3-4-1561-1X
1	1810	2.364-36	3.000	5.438	EY 6.5-4-4441-1X
2	1610	1.989-30	3.000	6.000	EY 5-4-8661-1 High angle yoke
2	1710	1.989-30	3.000	6.281	EY 6-4-8731-1 High angle yoke
3	1710	2.364-36	3.000	6.500	EY 6-4-8781-1X High angle yoke

Pos	Series	Spline Data	Hub Dia	* to End of Hub	End Fitting Part Number
-----	--------	-------------	---------	-----------------	-------------------------

N340-S

1	1610	2.114-32	3.000	2.844	CF 5-1-6691 .424 deep counterbore at hub end
1	1610	2.114-32	3.000	2.844	CF 5-1-6701X .424 deep counterbore at hub end
1	SPL140	2.114-32	3.000	4.810	EY 140-4-931-1X
1	SPL170	2.114-32	3.000	5.000	EY 170-4-891-1
1	SPL170	2.114-32	3.000	5.000	EY 170-4-901-1X
1	SPL170	2.114-32	3.000	6.312	EY 170-4-951-1 High angle yoke
1	SPL170	2.114-32	3.000	6.312	EY 170-4-961-1X High angle yoke
1	SPL250	2.114-32	3.000	5.240	EY 250-4-411-1
1	SPL250	2.114-32	3.000	5.240	EY 250-4-421-1X
1	SPL90	2.114-32	3.000	4.375	EY 90-4-581-1
1	SPL90	2.114-32	3.000	4.375	EY 90-4-591-1X
1	1480	2.114-32	3.000	4.281	EY 3-4-13341-1
1	1480	2.114-32	3.000	4.281	EY 3-4-13351-1X
1	1550	2.114-32	3.000	4.312	EY 4-4-6991-1
1	1550	2.114-32	3.000	4.312	EY 4-4-7001-1X
1	1610	2.114-32	3.000	5.375	EY 5-4-8601-1
1	1610	2.114-32	3.000	5.375	EY 5-4-8611-1X
1	1610	2.114-32	3.000	6.000	EY 5-4-8681-1 High angle yoke
1	1610	2.114-32	3.000	6.000	EY 5-4-8691-1X High angle yoke
1	1710	2.114-32	3.000	4.562	EY 6-4-8671-1
1	1710	2.114-32	3.000	4.562	EY 6-4-8681-1X
1	1710	2.114-32	3.000	6.062	EY 6-4-8751-1 High angle yoke
1	1710	2.114-32	3.000	6.062	EY 6-4-8761-1X High angle yoke
1	1760	2.114-32	3.000	5.000	EY 6.3-4-1511-1
1	1760	2.114-32	3.000	5.000	EY 6.3-4-1521-1X
1	1810	2.114-32	3.000	5.000	EY 6.5-4-4451-1
1	1810	2.114-32	3.000	5.000	EY 6.5-4-4461-1X
2	SPL140	2.114-32	3.000	4.810	EY 140-4-921-1
2	SPL170	1.790-34	2.500	5.030	EY 170-4-921-1
2	1610	1.790-34	2.500	5.438	EY 5-4-8911-1
2	1710	1.790-34	2.500	4.875	EY 6-4-9021-1
3	1610	2.114-32	3.000	2.844	CF 5-1-6691 .424 deep counterbore at hub end
3	1610	2.114-32	3.000	2.844	CF 5-1-6701X .424 deep counterbore at hub end
3	SPL140	2.114-32	3.000	4.810	EY 140-4-931-1X
3	SPL170	2.114-32	3.000	5.000	EY 170-4-891-1
3	SPL170	2.114-32	3.000	5.000	EY 170-4-901-1X
3	SPL170	2.114-32	3.000	6.312	EY 170-4-951-1 High angle yoke
3	SPL170	2.114-32	3.000	6.312	EY 170-4-961-1X High angle yoke

*C/L to End of Hub for EY (End Yoke); Flange Face to End of Hub for CF (Companion Flange)

■ Hub machined for speedometer gear



Pos	Series	Spline Data	Hub Dia	* to End of Hub	End Fitting Part Number
N340-S (Continued)					
3	SPL90	2.114-32	3.000	4.375	EY 90-4-581-1
3	SPL90	2.114-32	3.000	4.375	EY 90-4-591-1X
3	1480	2.114-32	3.000	4.281	EY 3-4-13341-1
3	1480	2.114-32	3.000	4.281	EY 3-4-13351-1X
3	1550	2.114-32	3.000	4.312	EY 4-4-6991-1
3	1550	2.114-32	3.000	4.312	EY 4-4-7001-1X
3	1610	2.114-32	3.000	5.375	EY 5-4-8601-1
3	1610	2.114-32	3.000	5.375	EY 5-4-8611-1X
3	1610	2.114-32	3.000	6.000	EY 5-4-8681-1 <i>High angle yoke</i>
3	1610	2.114-32	3.000	6.000	EY 5-4-8691-1X <i>High angle yoke</i>
3	1710	2.114-32	3.000	4.562	EY 6-4-8671-1
3	1710	2.114-32	3.000	4.562	EY 6-4-8681-1X
3	1710	2.114-32	3.000	6.062	EY 6-4-8751-1 <i>High angle yoke</i>
3	1710	2.114-32	3.000	6.062	EY 6-4-8761-1X <i>High angle yoke</i>
3	1760	2.114-32	3.000	5.000	EY 6.3-4-1511-1
3	1760	2.114-32	3.000	5.000	EY 6.3-4-1521-1X
3	1810	2.114-32	3.000	5.000	EY 6.5-4-4451-1
3	1810	2.114-32	3.000	5.000	EY 6.5-4-4461-1X

N400-S					
1	1610	2.114-32	3.000	2.844	CF 5-1-6691 <i>.424 deep counterbore at hub end</i>
1	1610	2.114-32	3.000	2.844	CF 5-1-6701X <i>.424 deep counterbore at hub end</i>
1	SPL140	2.114-32	3.000	4.810	EY 140-4-921-1
1	SPL140	2.114-32	3.000	4.810	EY 140-4-931-1X
1	SPL170	2.114-32	3.000	5.000	EY 170-4-891-1
1	SPL170	2.114-32	3.000	5.000	EY 170-4-901-1X
1	SPL170	2.114-32	3.000	6.312	EY 170-4-951-1 <i>High angle yoke</i>
1	SPL170	2.114-32	3.000	6.312	EY 170-4-961-1X <i>High angle yoke</i>
1	SPL250	2.114-32	3.000	5.240	EY 250-4-411-1
1	SPL250	2.114-32	3.000	5.240	EY 250-4-421-1X
1	SPL90	2.114-32	3.000	4.375	EY 90-4-581-1
1	SPL90	2.114-32	3.000	4.375	EY 90-4-591-1X
1	1480	2.114-32	3.000	4.281	EY 3-4-13341-1
1	1480	2.114-32	3.000	4.281	EY 3-4-13351-1X
1	1550	2.114-32	3.000	4.312	EY 4-4-6991-1
1	1550	2.114-32	3.000	4.312	EY 4-4-7001-1X
1	1610	2.114-32	3.000	5.375	EY 5-4-8601-1
1	1610	2.114-32	3.000	5.375	EY 5-4-8611-1X
1	1610	2.114-32	3.000	6.000	EY 5-4-8681-1 <i>High angle yoke</i>
1	1610	2.114-32	3.000	6.000	EY 5-4-8691-1X <i>High angle yoke</i>
1	1710	2.114-32	3.000	4.562	EY 6-4-8671-1
1	1710	2.114-32	3.000	4.562	EY 6-4-8681-1X
1	1710	2.114-32	3.000	6.062	EY 6-4-8751-1 <i>High angle yoke</i>
1	1710	2.114-32	3.000	6.062	EY 6-4-8761-1X <i>High angle yoke</i>
1	1760	2.114-32	3.000	5.000	EY 6.3-4-1511-1
1	1760	2.114-32	3.000	5.000	EY 6.3-4-1521-1X
1	1810	2.114-32	3.000	5.000	EY 6.5-4-4451-1
1	1810	2.114-32	3.000	5.000	EY 6.5-4-4461-1X
2	SPL170	1.790-34	2.500	5.030	EY 170-4-921-1

Pos	Series	Spline Data	Hub Dia	* to End of Hub	End Fitting Part Number
N400-S (Continued)					
2	1610	1.790-34	2.500	5.438	EY 5-4-8911-1
2	1710	1.790-34	2.500	4.875	EY 6-4-9021-1
3	1610	2.114-32	3.000	2.844	CF 5-1-6691 <i>.424 deep counterbore at hub end</i>
3	1610	2.114-32	3.000	2.844	CF 5-1-6701X <i>.424 deep counterbore at hub end</i>
3	SPL140	2.114-32	3.000	4.810	EY 140-4-921-1
3	SPL140	2.114-32	3.000	4.810	EY 140-4-931-1X
3	SPL170	2.114-32	3.000	5.000	EY 170-4-891-1
3	SPL170	2.114-32	3.000	5.000	EY 170-4-901-1X
3	SPL170	2.114-32	3.000	6.312	EY 170-4-951-1 <i>High angle yoke</i>
3	SPL170	2.114-32	3.000	6.312	EY 170-4-961-1X <i>High angle yoke</i>
3	SPL250	2.114-32	3.000	5.240	EY 250-4-411-1
3	SPL250	2.114-32	3.000	5.240	EY 250-4-421-1X
3	SPL90	2.114-32	3.000	4.375	EY 90-4-581-1
3	SPL90	2.114-32	3.000	4.375	EY 90-4-591-1X
3	1480	2.114-32	3.000	4.281	EY 3-4-13341-1
3	1480	2.114-32	3.000	4.281	EY 3-4-13351-1X
3	1550	2.114-32	3.000	4.312	EY 4-4-6991-1
3	1550	2.114-32	3.000	4.312	EY 4-4-7001-1X
3	1610	2.114-32	3.000	5.375	EY 5-4-8601-1
3	1610	2.114-32	3.000	5.375	EY 5-4-8611-1X
3	1610	2.114-32	3.000	6.000	EY 5-4-8681-1 <i>High angle yoke</i>
3	1610	2.114-32	3.000	6.000	EY 5-4-8691-1X <i>High angle yoke</i>
3	1710	2.114-32	3.000	4.562	EY 6-4-8671-1
3	1710	2.114-32	3.000	4.562	EY 6-4-8681-1X
3	1710	2.114-32	3.000	6.062	EY 6-4-8751-1 <i>High angle yoke</i>
3	1710	2.114-32	3.000	6.062	EY 6-4-8761-1X <i>High angle yoke</i>
3	1760	2.114-32	3.000	5.000	EY 6.3-4-1511-1
3	1760	2.114-32	3.000	5.000	EY 6.3-4-1521-1X
3	1810	2.114-32	3.000	5.000	EY 6.5-4-4451-1
3	1810	2.114-32	3.000	5.000	EY 6.5-4-4461-1X

R40-145					
3	SPL170	2.024-39	3.000	5.156	EY 170-4-1991-1X <i>High angle yoke</i>
3	SPL170	2.024-39	3.000	6.240	EY 170-4-2001-1X <i>High angle yoke</i>
3	1710	2.024-39	3.000	5.250	EY 6-4-10321-1X
3	1710	2.024-39	3.000	6.125	EY 6-4-10401-1X <i>High angle yoke</i>

S400					
1	SPL170	2.024-39	3.000	5.031	EY 170-4-841-1
1	SPL170	2.024-39	3.000	5.031	EY 170-4-851-1X
1	SPL250	2.024-39	3.000	5.240	EY 250-4-381-1
1	SPL250	2.024-39	3.000	5.240	EY 250-4-391-1X
1	1610	2.024-39	3.000	6.000	EY 5-4-9291-1 <i>High angle yoke</i>
1	1710	2.024-39	3.000	6.000	EY 6-4-9291-1 <i>High angle yoke</i>
1	1710	2.024-39	3.000	4.656	EY 6-4-9421-1
1	1710	2.024-39	3.000	4.656	EY 6-4-9441-1X
1	1760	2.024-39	3.000	5.625	EY 6.3-4-1701-1
1	1760	2.024-39	3.000	5.625	EY 6.3-4-1711-1X

Continued on next page

*C/L to End of Hub for EY (End Yoke); Flange Face to End of Hub for CF (Companion Flange)

■ Hub machined for speedometer gear



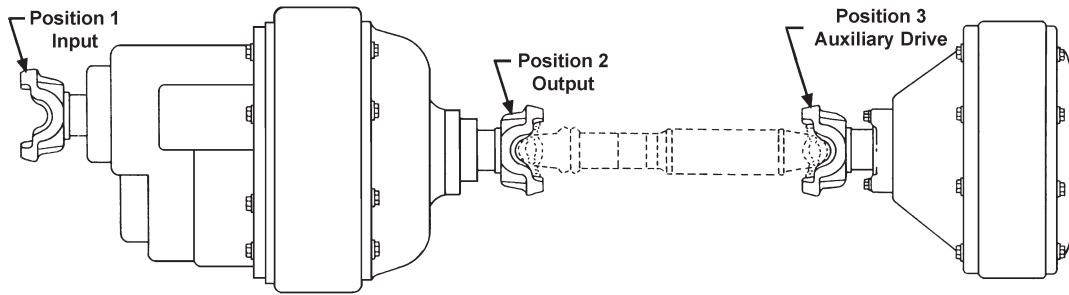

Pos	Series	Spline Data	Hub Dia	* to End of Hub	End Fitting Part Number
-----	--------	-------------	---------	-----------------	-------------------------

S400 (Continued)

1	1810	2.024-39	3.000	5.000	EY 6.5-4-4651-1
1	1810	2.024-39	3.000	5.000	EY 6.5-4-4661-1X
2	SPL170	2.024-39	3.000	5.280	EY 170-4-821-1
2	SPL170	2.024-39	3.000	6.500	EY 170-4-831-1 <i>High angle yoke</i>
2	1610	2.024-39	3.000	5.594	EY 5-4-9351-1
2	1710	2.024-39	3.000	6.120	EY 6-4-9281-1
2	1710	2.024-39	3.000	5.438	EY 6-4-9411-1
3	SPL170	2.024-39	3.000	6.250	EY 170-4-801-1 <i>High angle yoke</i>
3	SPL170	2.024-39	3.000	6.250	EY 170-4-811-1X <i>High angle yoke</i>
3	SPL170	2.024-39	3.000	5.031	EY 170-4-841-1
3	SPL170	2.024-39	3.000	5.031	EY 170-4-861-1X
3	1610	2.024-39	3.000	6.000	EY 5-4-9291-1 <i>High angle yoke</i>
3	1610	2.024-39	3.000	6.000	EY 5-4-9311-1X <i>High angle yoke</i>
3	1710	2.024-39	3.000	6.000	EY 6-4-9291-1 <i>High angle yoke</i>
3	1710	2.024-39	3.000	6.000	EY 6-4-9301-1X <i>High angle yoke</i>
3	1710	2.024-39	3.000	4.656	EY 6-4-9421-1
3	1710	2.024-39	3.000	4.656	EY 6-4-9431-1X

T170, T190

3	SPL170	2.544-49	3.820	6.810	EY 170-4-08461-1X 132931K = 170-4-08461-1X & nut# 131095; Spicer axles only
---	--------	----------	-------	-------	--

W460-S

1	SPL250	2.364-36	3.000	5.680	EY 250-4-361-1
1	SPL250	2.364-36	3.000	5.680	EY 250-4-371-1X
1	1610	2.364-36	3.000	5.156	EY 5-4-8641-1
1	1610	2.364-36	3.000	5.156	EY 5-4-8651-1X
1	1710	2.364-36	3.000	5.438	EY 6-4-8711-1
1	1710	2.364-36	3.000	5.438	EY 6-4-8721-1X
1	1760	2.364-36	3.000	5.438	EY 6.3-4-1551-1
1	1760	2.364-36	3.000	5.438	EY 6.3-4-1561-1X
1	1810	2.364-36	3.000	5.438	EY 6.5-4-4431-1
1	1810	2.364-36	3.000	5.438	EY 6.5-4-4441-1X
2	SPL170	1.989-30	3.000	6.580	EY 170-4-771-1 <i>High angle yoke</i>
2	1610	1.989-30	3.000	6.000	EY 5-4-8661-1 <i>High angle yoke</i>
2	1610	1.989-30	3.000	6.000	EY 5-4-8671-1X <i>High angle yoke</i>
2	1710	1.989-30	3.000	6.281	EY 6-4-8731-1 <i>High angle yoke</i>
3	SPL170	2.364-36	3.000	6.780	EY 170-4-781-1 <i>High angle yoke</i>
3	SPL170	2.364-36	3.000	6.780	EY 170-4-791-1X <i>High angle yoke</i>

Pos	Series	Spline Data	Hub Dia	* to End of Hub	End Fitting Part Number
-----	--------	-------------	---------	-----------------	-------------------------

W460-S (Continued)

3	1710	2.364-36	3.000	6.500	EY 6-4-8771-1 <i>High angle yoke</i>
3	1710	2.364-36	3.000	6.500	EY 6-4-8781-1X <i>High angle yoke</i>

22-MF, 22-MR, 28-MF, 28-MR

1	1480/1550	1.750-10	2.375	2.812	CF 4-1-3171
1	1350	1.750-10	2.375	4.000	EY 3-4-2351-1
1	1610	1.750-10	2.375	4.188	EY 5-4-1481
1	1610	1.750-10	2.375	4.688	EY 5-4-1481-1
3	1480/1550	1.750-10	2.375	2.812	CF 4-1-3171
3	1350	1.750-10	2.375	4.000	EY 3-4-2351-1
3	1610	1.750-10	2.375	4.188	EY 5-4-1481
3	1610	1.750-10	2.375	4.688	EY 5-4-1481-1

30R

1	1550	1.962-10	2.625	4.266	EY 4-4-4071-1X
1	1610	1.962-10	2.625	5.312	EY 5-4-4471-1
1	1610	1.962-10	2.625	6.000	EY 5-4-4771X <i>High angle yoke</i>
1	1610	1.962-10	2.625	4.719	EY 5-4-5121X
1	1710	1.964-10	2.625	4.500	EY 6-4-2211 <i>Chamfered Counterbore</i>
1	1710	1.962-10	2.625	4.500	EY 6-4-4731-1X <i>Chamfered Counterbore</i>
1	1710	1.962-10	2.625	4.500	EY 6-4-4731X <i>Chamfered Counterbore</i>
1	1710	1.962-10	2.625	6.125	EY 6-4-4851-1X <i>Chamfered Counterbore; High angle yoke</i>
1	1710	1.962-10	2.625	6.125	EY 6-4-4851X <i>Chamfered Counterbore; High angle yoke</i>
1	1710	1.962-10	2.625	5.250	EY 6-4-5151X <i>Chamfered Counterbore</i>
1	1760	1.964-10	2.625	5.625	EY 6.3-4-221X <i>Chamfered Counterbore</i>
1	1810	1.964-10	2.625	5.625	EY 6.5-4-2351X <i>Chamfered Counterbore</i>
2	1410	1.750-10	2.625	4.250	EY 3-4-2511-1 <i>.250 deep spline chamfer</i>
2	1550	1.750-10	2.625	4.672	EY 4-4-3581-1X <i>.250 deep spline chamfer</i>
2	1610	1.750-10	2.625	6.000	EY 5-4-4761X <i>High angle yoke</i>
2	1610	1.750-10	2.625	4.750	EY 5-4-5111X
2	1710	1.750-10	2.625	5.250	EY 6-4-4301X <i>Chamfered Counterbore</i>
2	1710	1.750-10	2.625	6.125	EY 6-4-4861X <i>Chamfered Counterbore; High angle yoke</i>
2	1710	1.750-10	2.625	4.500	EY 6-4-5581-1X <i>Chamfered Counterbore</i>
2	1710	1.750-10	2.625	4.500	EY 6-4-5581X <i>Chamfered Counterbore</i>

*C/L to End of Hub for EY (End Yoke); Flange Face to End of Hub for CF (Companion Flange)

■ Hub machined for speedometer gear



Pos	Series	Spline Data	Hub Dia	* to End of Hub	End Fitting Part Number
30R (Continued)					
3	1410	1.750-10	2.625	4.250	EY 3-4-2511-1 <i>All ratios except 3.70 & 4.11; .250 deep spline chamfer</i>
3	1480	1.750-10	2.625	4.281	EY 3-4-5791-1X <i>.250 deep spline chamfer; C'bore depth is chamfered</i>
3	1550	1.750-10	2.625	4.672	EY 4-4-3581-1X <i>.250 deep spline chamfer</i>
3	1610	1.750-10	2.625	6.000	EY 5-4-4761X <i>All ratios except 3.70 & 4.11; High angle yoke</i>
3	1610	1.962-10	2.625	6.000	EY 5-4-4771X <i>3.70 & 4.11 ratios only; High angle yoke</i>
3	1610	1.750-10	2.625	4.750	EY 5-4-5111X <i>All ratios except 3.70 & 4.11</i>
3	1610	1.962-10	2.625	4.719	EY 5-4-5121X <i>3.70 & 4.11 ratios only</i>
3	1710	1.750-10	2.625	5.250	EY 6-4-4301X <i>All ratios except 3.70 & 4.11; Chamfered Counterbore</i>
3	1710	1.962-10	2.625	6.125	EY 6-4-4851-1X <i>3.70 & 4.11 ratios only; Chamfered Counterbore; High angle yoke</i>
3	1710	1.962-10	2.625	6.125	EY 6-4-4851X <i>3.70 & 4.11 ratios only; Chamfered Counterbore; High angle yoke</i>
3	1710	1.750-10	2.625	6.125	EY 6-4-4861X <i>All ratios except 3.70 & 4.11; Chamfered Counterbore; High angle yoke</i>
3	1710	1.962-10	2.625	5.250	EY 6-4-5151X <i>3.70 & 4.11 ratios only; Chamfered Counterbore</i>
3	1710	1.750-10	2.625	4.500	EY 6-4-5581-1X <i>All ratios except 3.70 & 4.11; Chamfered Counterbore</i>
3	1710	1.750-10	2.625	4.500	EY 6-4-5581X <i>All ratios except 3.70 & 4.11; Chamfered Counterbore</i>

32-MF, 32-MR					
1	1480/1550	1.750-10	2.375	2.812	CF 4-1-3171
1	1610	1.750-10	2.375	4.188	EY 5-4-1481
1	1610	1.750-10	2.375	4.688	EY 5-4-1481-1
2	1610	1.750-10	2.375	4.188	EY 5-4-1481
2	1610	1.750-10	2.375	4.688	EY 5-4-1481-1
3	1410	1.750-10	2.625	4.250	EY 3-4-2511-1 <i>.250 deep spline chamfer</i>
3	1550	1.750-10	2.625	4.672	EY 4-4-3581-1X <i>.250 deep spline chamfer</i>
3	1610	1.750-10	2.625	4.125	EY 5-4-781
3	1650	1.750-10	2.625	4.375	EY 5-4-4161X <i>Chamfered Counterbore</i>

34-MF, 34-MR					
1	1480/1550	1.750-10	2.375	2.812	CF 4-1-3171
1	1610	1.750-10	2.375	4.188	EY 5-4-1481
1	1610	1.750-10	2.375	4.688	EY 5-4-1481-1
2	1610	1.750-10	2.375	4.188	EY 5-4-1481
2	1610	1.750-10	2.375	4.688	EY 5-4-1481-1
3	1410	1.750-10	2.625	4.250	EY 3-4-2511-1 <i>.250 deep spline chamfer</i>
3	1610	1.750-10	2.625	4.125	EY 5-4-781
3	1650	1.750-10	2.625	4.375	EY 5-4-4161X <i>Chamfered Counterbore</i>

34D					
1	1550	1.962-10	2.625	4.266	EY 4-4-4071-1X
1	1610	1.962-10	2.625	5.312	EY 5-4-4471-1
1	1610	1.962-10	2.625	6.000	EY 5-4-4771X <i>High angle yoke</i>
1	1610	1.962-10	2.625	4.719	EY 5-4-5121X <i>Chamfered Counterbore</i>
1	1710	1.964-10	2.625	4.500	EY 6-4-2211 <i>Chamfered Counterbore</i>
1	1710	1.962-10	2.625	6.125	EY 6-4-4151 <i>Chamfered Counterbore, High angle yoke</i>

Pos	Series	Spline Data	Hub Dia	* to End of Hub	End Fitting Part Number
34D(Continued)					
1	1710	1.962-10	2.625	6.125	EY 6-4-4151-1 <i>Chamfered Counterbore, High angle yoke</i>
1	1710	1.962-10	2.625	4.500	EY 6-4-4721 <i>Chamfered Counterbore</i>
1	1710	1.962-10	2.625	4.500	EY 6-4-4731-1X <i>Chamfered Counterbore</i>
1	1710	1.962-10	2.625	4.500	EY 6-4-4731X <i>Chamfered Counterbore</i>
1	1710	1.962-10	2.625	6.125	EY 6-4-4851-1X <i>Chamfered Counterbore; High angle yoke</i>
1	1710	1.962-10	2.625	6.125	EY 6-4-4851X <i>Chamfered Counterbore; High angle yoke</i>
1	1710	1.962-10	2.625	5.250	EY 6-4-5151X <i>Chamfered Counterbore</i>
1	1710	2.274-44	2.938	5.188	EY 6-4-8551X
1	1760	2.274-44	2.938	5.250	EY 6.3-4-1481X
1	1760	1.964-10	2.625	5.625	EY 6.3-4-221X <i>Chamfered Counterbore</i>
1	1810	1.964-10	2.625	5.625	EY 6.5-4-2351X <i>Chamfered Counterbore</i>
1	1810	2.274-44	2.938	5.250	EY 6.5-4-4351X
2	1410	1.750-10	2.625	4.250	EY 3-4-2511-1 <i>.250 deep spline chamfer</i>
2	1610	1.750-10	2.625	6.000	EY 5-4-4761X <i>High angle yoke</i>
2	1610	1.750-10	2.625	4.750	EY 5-4-5111X
2	1610	1.790-34	2.625	6.188	EY 5-4-8441X <i>High angle yoke</i>
2	1710	1.750-10	2.625	5.250	EY 6-4-4301X <i>Chamfered Counterbore</i>
2	1710	1.750-10	2.625	6.125	EY 6-4-4861X <i>Chamfered Counterbore; High angle yoke</i>
2	1710	1.750-10	2.625	4.500	EY 6-4-5581-1X <i>Chamfered Counterbore</i>
2	1710	1.750-10	2.625	4.500	EY 6-4-5581X <i>Chamfered Counterbore</i>
2	1710	1.790-34	2.625	5.438	EY 6-4-8511X
2	1710	1.790-34	2.625	6.312	EY 6-4-8521X <i>High angle yoke</i>
3	1410	1.750-10	2.625	4.250	EY 3-4-2511-1 <i>All ratios except 3.70 & 4.11; .250 deep spline chamfer</i>
3	1610	1.750-10	2.625	6.000	EY 5-4-4761X <i>All ratios except 3.70 & 4.11; High angle yoke</i>
3	1610	1.962-10	2.625	6.000	EY 5-4-4771X <i>3.70 & 4.11 ratios only; High angle yoke</i>
3	1610	1.750-10	2.625	4.750	EY 5-4-5111X <i>All ratios except 3.70 & 4.11</i>
3	1610	1.962-10	2.625	4.719	EY 5-4-5121X <i>3.70 & 4.11 ratios only</i>
3	1610	2.024-39	2.625	4.719	EY 5-4-8131-1X
3	1610	2.024-39	2.625	5.312	EY 5-4-8411X
3	1610	2.024-39	2.625	6.000	EY 5-4-8421X <i>High angle yoke</i>
3	1610	1.962-10	2.625	5.312	EY 5-4-8901-1X <i>C'bore depth is chamfered</i>
3	1710	1.962-10	2.625	6.125	EY 6-4-4151 <i>Chamfered Counterbore</i>
3	1710	1.962-10	2.625	6.125	EY 6-4-4151-1 <i>Chamfered Counterbore; High angle yoke</i>
3	1710	1.750-10	2.625	5.250	EY 6-4-4301X <i>All ratios except 3.70 & 4.11; Chamfered Counterbore</i>

Continued on next page

*C/L to End of Hub for EY (End Yoke); Flange Face to End of Hub for CF (Companion Flange)

■ Hub machined for speedometer gear



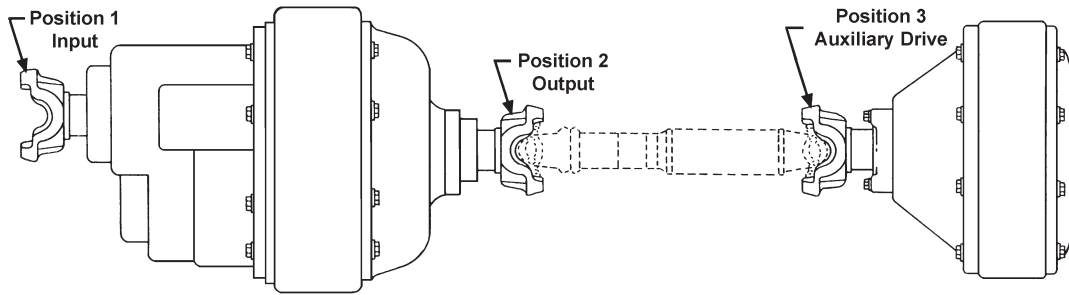

Pos	Series	Spline Data	Hub Dia	* to End of Hub	End Fitting Part Number
-----	--------	-------------	---------	-----------------	-------------------------

34D(Continued)

3	1710	1.962-10	2.625	6.125	EY 6-4-4851-1X
<i>3.70 & 4.11 ratios only; Chamfered Counterbore; High angle yoke</i>					
3	1710	1.962-10	2.625	6.125	EY 6-4-4851X
<i>3.70 & 4.11 ratios only; Chamfered Counterbore; High angle yoke</i>					
3	1710	1.750-10	2.625	6.125	EY 6-4-4861X
<i>All ratios except 3.70 & 4.11; Chamfered Counterbore; High angle yoke</i>					
3	1710	1.962-10	2.625	5.250	EY 6-4-5151X
<i>3.70 & 4.11 ratios only; Chamfered Counterbore</i>					
3	1710	1.750-10	2.625	4.500	EY 6-4-5581-1X
<i>All ratios except 3.70 & 4.11; Chamfered Counterbore</i>					
3	1710	1.750-10	2.625	4.500	EY 6-4-5581X
<i>All ratios except 3.70 & 4.11; Chamfered Counterbore</i>					
3	1710	2.024-39	2.625	5.250	EY 6-4-8531X
3	1710	2.024-39	2.625	6.125	EY 6-4-8541X
<i>High angle yoke</i>					

34R

1	1550	1.962-10	2.625	4.266	EY 4-4-4071-1X
1	1610	1.962-10	2.625	5.312	EY 5-4-4471-1
1	1610	1.962-10	2.625	6.000	EY 5-4-4771X
<i>High angle yoke</i>					
1	1610	1.962-10	2.625	4.719	EY 5-4-5121X
1	1710	1.964-10	2.625	4.500	EY 6-4-2211
<i>Chamfered Counterbore</i>					
1	1710	1.962-10	2.625	6.125	EY 6-4-4151
<i>Chamfered Counterbore; High angle yoke</i>					
1	1710	1.962-10	2.625	6.125	EY 6-4-4151-1
<i>Chamfered Counterbore; High angle yoke</i>					
1	1710	1.962-10	2.625	4.500	EY 6-4-4721
<i>Chamfered Counterbore</i>					
1	1710	1.962-10	2.625	4.500	EY 6-4-4731-1X
<i>Chamfered Counterbore</i>					
1	1710	1.962-10	2.625	4.500	EY 6-4-4731X
<i>Chamfered Counterbore</i>					
1	1710	1.962-10	2.625	6.125	EY 6-4-4851-1X
<i>Chamfered Counterbore; High angle yoke</i>					
1	1710	1.962-10	2.625	6.125	EY 6-4-4851X
<i>Chamfered Counterbore; High angle yoke</i>					
1	1710	1.962-10	2.625	5.250	EY 6-4-5151X
<i>Chamfered Counterbore</i>					
1	1760	1.964-10	2.625	5.625	EY 6.3-4-221X
<i>Chamfered Counterbore</i>					
1	1810	1.964-10	2.625	5.625	EY 6.5-4-2351X
<i>Chamfered Counterbore</i>					
2	1410	1.750-10	2.625	4.250	EY 3-4-2511-1
<i>.250 deep spline chamfer</i>					
2	1480	1.750-10	2.625	4.281	EY 3-4-5791-1X
<i>.250 deep spline chamfer; C'bore depth is chamfered</i>					
2	1550	1.750-10	2.625	4.672	EY 4-4-3581-1X
<i>.250 deep spline chamfer</i>					
2	1610	1.750-10	2.625	6.000	EY 5-4-4761X
<i>High angle yoke</i>					

Pos	Series	Spline Data	Hub Dia	* to End of Hub	End Fitting Part Number
-----	--------	-------------	---------	-----------------	-------------------------

34R (Continued)

2	1610	1.750-10	2.625	4.750	EY 5-4-5111X
2	1710	1.750-10	2.625	5.250	EY 6-4-4301X
<i>Chamfered Counterbore</i>					
2	1710	1.750-10	2.625	6.125	EY 6-4-4861X
<i>Chamfered Counterbore; High angle yoke</i>					
2	1710	1.750-10	2.625	4.500	EY 6-4-5581-1X
<i>Chamfered Counterbore</i>					
2	1710	1.750-10	2.625	4.500	EY 6-4-5581X
<i>Chamfered Counterbore</i>					
3	1410	1.750-10	2.625	4.250	EY 3-4-2511-1
<i>All ratios except 3.70 & 4.11</i>					
3	1480	1.750-10	2.625	4.281	EY 3-4-5791-1X
<i>.250 deep spline chamfer</i>					
3	1480	1.750-10	2.625	4.281	EY 3-4-5791-1X
<i>.250 deep spline chamfer; C'bore depth is chamfered</i>					
3	1550	1.750-10	2.625	4.672	EY 4-4-3581-1X
<i>.250 deep spline chamfer</i>					
3	1610	1.750-10	2.625	6.000	EY 5-4-4761X
<i>All ratios except 3.70 & 4.11; High angle yoke</i>					
3	1610	1.962-10	2.625	6.000	EY 5-4-4771X
<i>3.70 & 4.11 ratios only</i>					
3	1610	1.750-10	2.625	4.750	EY 5-4-5111X
<i>All ratios except 3.70 & 4.11</i>					
3	1610	1.962-10	2.625	4.719	EY 5-4-5121X
<i>3.70 & 4.11 ratios only</i>					
3	1710	1.750-10	2.625	5.250	EY 6-4-4301X
<i>All ratios except 3.70 & 4.11; Chamfered Counterbore</i>					
3	1710	1.962-10	2.625	6.125	EY 6-4-4851-1X
<i>3.70 & 4.11 ratios only; Chamfered Counterbore; High angle yoke</i>					
3	1710	1.962-10	2.625	6.125	EY 6-4-4851X
<i>3.70 & 4.11 ratios only; Chamfered Counterbore; High angle yoke</i>					
3	1710	1.750-10	2.625	6.125	EY 6-4-4861X
<i>All ratios except 3.70 & 4.11; Chamfered Counterbore; High angle yoke</i>					
3	1710	1.962-10	2.625	5.250	EY 6-4-5151X
<i>3.70 & 4.11 ratios only; Chamfered Counterbore</i>					
3	1710	1.750-10	2.625	4.500	EY 6-4-5581-1X
<i>All ratios except 3.70 & 4.11; Chamfered Counterbore</i>					
3	1710	1.750-10	2.625	4.500	EY 6-4-5581X
<i>All ratios except 3.70 & 4.11; Chamfered Counterbore</i>					

36-MF, 36-MR

1	1550	1.962-10	2.625	4.266	EY 4-4-4071-1X
1	1610	1.962-10	2.625	4.719	EY 5-4-5121-1X
1	1610	1.962-10	2.625	4.719	EY 5-4-5121X
1	1710	1.964-10	2.625	4.500	EY 6-4-2211
<i>Chamfered Counterbore</i>					
1	1710	1.962-10	2.625	5.250	EY 6-4-5151X
<i>Chamfered Counterbore</i>					

*C/L to End of Hub for EY (End Yoke); Flange Face to End of Hub for CF (Companion Flange)

■ Hub machined for speedometer gear



Pos	Series	Spline Data	Hub Dia	* to End of Hub	End Fitting Part Number
38D					
1	1550	1.962-10	2.625	4.266	EY 4-4-4071-1X
1	1610	1.962-10	2.625	5.312	EY 5-4-4471-1
1	1610	1.962-10	2.625	6.000	EY 5-4-4771X <i>High angle yoke</i>
1	1610	1.962-10	2.625	4.719	EY 5-4-5121X
1	1710	1.964-10	2.625	4.500	EY 6-4-2211 <i>Chamfered Counterbore</i>
1	1710	1.962-10	2.625	6.125	EY 6-4-4151 <i>Chamfered Counterbore; High angle yoke</i>
1	1710	1.962-10	2.625	6.125	EY 6-4-4151-1 <i>Chamfered Counterbore; High angle yoke</i>
1	1710	1.962-10	2.625	4.500	EY 6-4-4721 <i>Chamfered Counterbore</i>
1	1710	1.962-10	2.625	4.500	EY 6-4-4731-1X <i>Chamfered Counterbore</i>
1	1710	1.962-10	2.625	4.500	EY 6-4-4731X <i>Chamfered Counterbore</i>
1	1710	1.962-10	2.625	6.125	EY 6-4-4851-1X <i>Chamfered Counterbore High angle yoke</i>
1	1710	1.962-10	2.625	6.125	EY 6-4-4851X <i>Chamfered Counterbore High angle yoke</i>
1	1710	1.962-10	2.625	5.250	EY 6-4-5151X <i>Chamfered Counterbore</i>
1	1710	2.274-44	2.938	5.188	EY 6-4-8551X
1	1760	2.274-44	2.938	5.250	EY 6.3-4-1481X
1	1760	1.964-10	2.625	5.625	EY 6.3-4-221X <i>Chamfered Counterbore</i>
1	1810	1.964-10	2.625	5.625	EY 6.5-4-2351X <i>Chamfered Counterbore</i>
1	1810	2.274-44	2.938	5.250	EY 6.5-4-4351X
2	1410	1.750-10	2.625	4.250	EY 3-4-2511-1 <i>.250 deep spline chamfer</i>
2	1610	1.750-10	2.625	6.000	EY 5-4-4761X <i>High angle yoke</i>
2	1610	1.750-10	2.625	4.750	EY 5-4-5111X
2	1610	1.790-34	2.625	6.188	EY 5-4-8441X <i>High angle yoke</i>
2	1710	1.750-10	2.625	5.250	EY 6-4-4301X <i>Chamfered Counterbore</i>
2	1710	1.750-10	2.625	6.125	EY 6-4-4861X <i>Chamfered Counterbore; High angle yoke</i>
2	1710	1.750-10	2.625	4.500	EY 6-4-5581-1X <i>Chamfered Counterbore</i>
2	1710	1.750-10	2.625	4.500	EY 6-4-5581X <i>Chamfered Counterbore</i>
2	1710	1.790-34	2.625	5.438	EY 6-4-8511X
2	1710	1.790-34	2.625	6.312	EY 6-4-8521X <i>High angle yoke</i>
3	1410	1.750-10	2.625	4.250	EY 3-4-2511-1 <i>All ratios except 3.70 & 4.11; .250 deep spline chamfer</i>
3	1610	1.750-10	2.625	6.000	EY 5-4-4761X <i>All ratios except 3.70 & 4.11; High angle yoke</i>
3	1610	1.962-10	2.625	6.000	EY 5-4-4771X <i>3.70 & 4.11 ratios only; High angle yoke</i>
3	1610	1.750-10	2.625	4.750	EY 5-4-5111X <i>All ratios except 3.70 & 4.11</i>
3	1610	1.962-10	2.625	4.719	EY 5-4-5121X <i>3.70 & 4.11 ratios only</i>
3	1610	2.024-39	2.625	4.719	EY 5-4-8131-1X
3	1610	2.024-39	2.625	5.312	EY 5-4-8411X
3	1610	2.024-39	2.625	6.000	EY 5-4-8421X <i>High angle yoke</i>

Pos	Series	Spline Data	Hub Dia	* to End of Hub	End Fitting Part Number
38D (Continued)					
3	1610	1.962-10	2.625	5.312	EY 5-4-8901-1X <i>C bore depth is chamfered</i>
3	1710	1.962-10	2.625	6.125	EY 6-4-4151 <i>Chamfered Counterbore; High angle yoke</i>
3	1710	1.962-10	2.625	6.125	EY 6-4-4151-1 <i>Chamfered Counterbore; High angle yoke</i>
3	1710	1.750-10	2.625	5.250	EY 6-4-4301X <i>All ratios except 3.70 & 4.11; Chamfered Counterbore</i>
3	1710	1.962-10	2.625	6.125	EY 6-4-4851-1X <i>3.70 & 4.11 ratios only; Chamfered Counterbore; High angle yoke</i>
3	1710	1.962-10	2.625	6.125	EY 6-4-4851X <i>3.70 & 4.11 ratios only; Chamfered Counterbore; High angle yoke</i>
3	1710	1.750-10	2.625	6.125	EY 6-4-4861X <i>All ratios except 3.70 & 4.11; Chamfered Counterbore; High angle yoke</i>
3	1710	1.962-10	2.625	5.250	EY 6-4-5151X <i>3.70 & 4.11 ratios only; Chamfered Counterbore</i>
3	1710	1.750-10	2.625	4.500	EY 6-4-5581-1X <i>All ratios except 3.70 & 4.11; Chamfered Counterbore</i>
3	1710	1.750-10	2.625	4.500	EY 6-4-5581X <i>All ratios except 3.70 & 4.11; Chamfered Counterbore</i>
3	1710	2.024-39	2.625	5.250	EY 6-4-8531X
3	1710	2.024-39	2.625	6.125	EY 6-4-8541X <i>High angle yoke</i>

Pos	Series	Spline Data	Hub Dia	* to End of Hub	End Fitting Part Number
38R					
1	1550	1.962-10	2.625	4.266	EY 4-4-4071-1X
1	1610	1.962-10	2.625	5.312	EY 5-4-4471-1
1	1610	1.962-10	2.625	6.000	EY 5-4-4771X <i>High angle yoke</i>
1	1610	1.962-10	2.625	4.719	EY 5-4-5121X
1	1710	1.964-10	2.625	4.500	EY 6-4-2211 <i>Chamfered Counterbore</i>
1	1710	1.962-10	2.625	6.125	EY 6-4-4151 <i>Chamfered Counterbore; High angle yoke</i>
1	1710	1.962-10	2.625	6.125	EY 6-4-4151-1 <i>Chamfered Counterbore; High angle yoke</i>
1	1710	1.962-10	2.625	4.500	EY 6-4-4721 <i>Chamfered Counterbore</i>
1	1710	1.962-10	2.625	4.500	EY 6-4-4731-1X <i>Chamfered Counterbore</i>
1	1710	1.962-10	2.625	4.500	EY 6-4-4731X <i>Chamfered Counterbore</i>
1	1710	1.962-10	2.625	6.125	EY 6-4-4851-1X <i>Chamfered Counterbore; High angle yoke</i>
1	1710	1.962-10	2.625	6.125	EY 6-4-4851X <i>Chamfered Counterbore; High angle yoke</i>
1	1710	1.962-10	2.625	5.250	EY 6-4-5151X <i>Chamfered Counterbore</i>
1	1760	1.964-10	2.625	5.625	EY 6.3-4-221X <i>Chamfered Counterbore</i>
1	1810	1.964-10	2.625	5.625	EY 6.5-4-2351X <i>Chamfered Counterbore</i>
2	1410	1.750-10	2.625	4.250	EY 3-4-2511-1 <i>.250 deep spline chamfer</i>
2	1480	1.750-10	2.625	4.281	EY 3-4-5791-1X <i>.250 deep spline chamfer; C bore depth is chamfered</i>
2	1550	1.750-10	2.625	4.672	EY 4-4-3581-1X <i>.250 deep spline chamfer</i>
2	1610	1.750-10	2.625	6.000	EY 5-4-4761X <i>High angle yoke</i>
2	1610	1.750-10	2.625	4.750	EY 5-4-5111X
2	1710	1.750-10	2.625	5.250	EY 6-4-4301X <i>Chamfered Counterbore</i>

Continued on next page

*C/L to End of Hub for EY (End Yoke); Flange Face to End of Hub for CF (Companion Flange)

■ Hub machined for speedometer gear



Important: See Safety Information in General Information Section (J300P-GI)

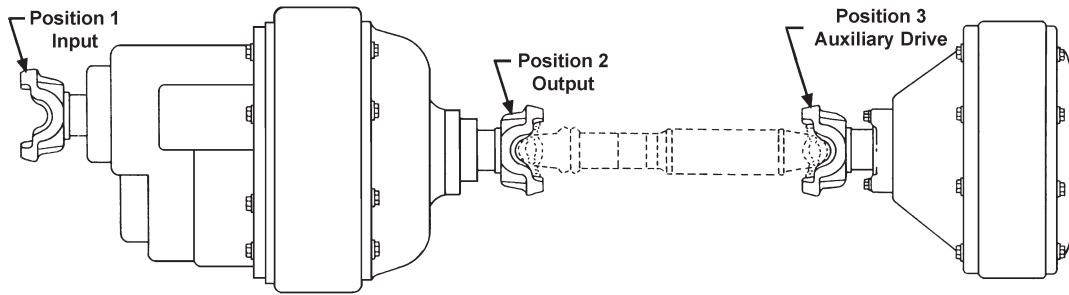

Pos	Series	Spline Data	Hub Dia	* to End of Hub	End Fitting Part Number
-----	--------	-------------	---------	-----------------	-------------------------

38R (Continued)

2	1710	1.750-10	2.625	6.125	EY 6-4-4861X <i>Chamfered Counterbore; High angle yoke</i>
2	1710	1.750-10	2.625	4.500	EY 6-4-5581-1X <i>Chamfered Counterbore</i>
2	1710	1.750-10	2.625	4.500	EY 6-4-5581X <i>Chamfered Counterbore</i>
3	1410	1.750-10	2.625	4.250	EY 3-4-2511-1 <i>All ratios except 3.70 & 4.11; .250 deep spline chamfer</i>
3	1480	1.750-10	2.625	4.281	EY 3-4-5791-1X <i>.250 deep spline chamfer; C'bore depth is chamfered</i>
3	1550	1.750-10	2.625	4.672	EY 4-4-3581-1X <i>.250 deep spline chamfer</i>
3	1610	1.750-10	2.625	6.000	EY 5-4-4761X <i>All ratios except 3.70 & 4.11; High angle yoke</i>
3	1610	1.962-10	2.625	6.000	EY 5-4-4771X <i>3.70 & 4.11 ratios only; High angle yoke</i>
3	1610	1.750-10	2.625	4.750	EY 5-4-5111X <i>All ratios except 3.70 & 4.11</i>
3	1610	1.962-10	2.625	4.719	EY 5-4-5121X <i>3.70 & 4.11 ratios only</i>
3	1710	1.962-10	2.625	6.125	EY 6-4-4151 <i>Chamfered Counterbore; High angle yoke</i>
3	1710	1.962-10	2.625	6.125	EY 6-4-4151-1 <i>Chamfered Counterbore; High angle yoke</i>
3	1710	1.750-10	2.625	5.250	EY 6-4-4301X <i>All ratios except 3.70 & 4.11; Chamfered Counterbore</i>
3	1710	1.962-10	2.625	6.125	EY 6-4-4851-1X <i>3.70 & 4.11 ratios only; Chamfered Counterbore; High angle yoke</i>
3	1710	1.962-10	2.625	6.125	EY 6-4-4851X <i>3.70 & 4.11 ratios only; Chamfered Counterbore; High angle yoke</i>
3	1710	1.750-10	2.625	6.125	EY 6-4-4861X <i>All ratios except 3.70 & 4.11; Chamfered Counterbore; High angle yoke</i>
3	1710	1.962-10	2.625	5.250	EY 6-4-5151X <i>3.70 & 4.11 ratios only; Chamfered Counterbore</i>
3	1710	1.750-10	2.625	4.500	EY 6-4-5581-1X <i>All ratios except 3.70 & 4.11; Chamfered Counterbore</i>
3	1710	1.750-10	2.625	4.500	EY 6-4-5581X <i>All ratios except 3.70 & 4.11; Chamfered Counterbore</i>

42-MF, 42-MR

2	1550	1.962-10	2.625	4.266	EY 4-4-4071-1X
2	1610	1.962-10	2.625	5.312	EY 5-4-4471-1
2	1710	1.962-10	2.625	4.500	EY 6-4-4731X <i>Chamfered Counterbore</i>
2	1710	1.962-10	2.625	6.125	EY 6-4-4851X <i>Chamfered Counterbore; High angle yoke</i>
2	1810	1.964-10	2.625	5.625	EY 6.5-4-2351X <i>Chamfered Counterbore</i>
3	1550	1.962-10	2.625	4.266	EY 4-4-4071-1X
3	1610	1.962-10	2.625	5.312	EY 5-4-4471-1
3	1710	1.962-10	2.625	4.500	EY 6-4-4731X <i>Chamfered Counterbore</i>

Pos	Series	Spline Data	Hub Dia	* to End of Hub	End Fitting Part Number
-----	--------	-------------	---------	-----------------	-------------------------

42-MF, 42-MR (Continued)

3	1710	1.962-10	2.625	6.125	EY 6-4-4851X <i>Chamfered Counterbore; High angle yoke</i>
3	1810	1.964-10	2.625	5.625	EY 6.5-4-2351X <i>Chamfered Counterbore</i>
42D					
1	1550	1.962-10	2.625	4.266	EY 4-4-4071-1X
1	1610	1.962-10	2.625	5.312	EY 5-4-4471-1
1	1610	1.962-10	2.625	6.000	EY 5-4-4771X <i>High angle yoke</i>
1	1610	1.962-10	2.625	4.719	EY 5-4-5121X
1	1710	1.964-10	2.625	4.500	EY 6-4-2211 <i>Chamfered Counterbore</i>
1	1710	1.962-10	2.625	6.125	EY 6-4-4151 <i>Chamfered Counterbore; High angle yoke</i>
1	1710	1.962-10	2.625	6.125	EY 6-4-4151-1 <i>Chamfered Counterbore; High angle yoke</i>
1	1710	1.962-10	2.625	4.500	EY 6-4-4721 <i>Chamfered Counterbore</i>
1	1710	1.962-10	2.625	4.500	EY 6-4-4731-1X <i>Chamfered Counterbore</i>
1	1710	1.962-10	2.625	4.500	EY 6-4-4731X <i>Chamfered Counterbore</i>
1	1710	1.962-10	2.625	6.125	EY 6-4-4851-1X <i>Chamfered Counterbore; High angle yoke</i>
1	1710	1.962-10	2.625	6.125	EY 6-4-4851X <i>Chamfered Counterbore; High angle yoke</i>
1	1760	1.964-10	2.625	5.625	EY 6.3-4-221X <i>Chamfered Counterbore</i>
1	1810	1.964-10	2.625	5.625	EY 6.5-4-2351X <i>Chamfered Counterbore</i>
2	1410	1.750-10	2.625	4.250	EY 3-4-2511-1 <i>.250 deep spline chamfer</i>
2	1480	1.750-10	2.625	4.281	EY 3-4-5791-1X <i>.250 deep spline chamfer; C'bore depth is chamfered</i>
2	1550	1.750-10	2.625	4.672	EY 4-4-3581-1X <i>.250 deep spline chamfer</i>
2	1610	1.750-10	2.625	6.000	EY 5-4-4761X <i>High angle yoke</i>
2	1610	1.750-10	2.625	4.750	EY 5-4-5111X
2	1710	1.750-10	2.625	5.250	EY 6-4-4301X <i>Chamfered Counterbore</i>
2	1710	1.750-10	2.625	6.125	EY 6-4-4861X <i>Chamfered Counterbore; High angle yoke</i>
2	1710	1.750-10	2.625	4.500	EY 6-4-5581-1X <i>Chamfered Counterbore</i>
2	1710	1.750-10	2.625	4.500	EY 6-4-5581X <i>Chamfered Counterbore</i>
3	1410	1.750-10	2.625	4.250	EY 3-4-2511-1 <i>.250 deep spline chamfer</i>
3	1480	1.750-10	2.625	4.281	EY 3-4-5791-1X <i>.250 deep spline chamfer; C'bore depth is chamfered</i>

*C/L to End of Hub for EY (End Yoke); Flange Face to End of Hub for CF (Companion Flange)

■ Hub machined for speedometer gear



Pos	Series	Spline Data	Hub Dia	* to End of Hub	End Fitting Part Number
42D (Continued)					
3	1550	1.750-10	2.625	4.672	EY 4-4-3581-1X .250 deep spline chamfer
3	1610	1.750-10	2.625	6.000	EY 5-4-4761X High angle yoke
3	1610	1.962-10	2.625	6.000	EY 5-4-4771X High angle yoke
3	1610	1.750-10	2.625	4.750	EY 5-4-5111X
3	1610	1.962-10	2.625	4.719	EY 5-4-5121X
3	1710	1.962-10	2.625	6.125	EY 6-4-4151 Chamfered Counterbore; High angle yoke
3	1710	1.962-10	2.625	6.125	EY 6-4-4151-1 Chamfered Counterbore; High angle yoke
3	1710	1.750-10	2.625	5.250	EY 6-4-4301X Chamfered Counterbore
3	1710	1.962-10	2.625	6.125	EY 6-4-4851-1X Chamfered Counterbore; High angle yoke
3	1710	1.962-10	2.625	6.125	EY 6-4-4851X Chamfered Counterbore; High angle yoke
3	1710	1.750-10	2.625	6.125	EY 6-4-4861X Chamfered Counterbore; High angle yoke
3	1710	1.962-10	2.625	5.250	EY 6-4-5151X Chamfered Counterbore
3	1710	1.750-10	2.625	4.500	EY 6-4-5581-1X Chamfered Counterbore
3	1710	1.750-10	2.625	4.500	EY 6-4-5581X Chamfered Counterbore

42R					
1	1550	1.962-10	2.625	4.266	EY 4-4-4071-1X
1	1610	1.962-10	2.625	5.312	EY 5-4-4471-1
1	1610	1.962-10	2.625	6.000	EY 5-4-4771X High angle yoke
1	1610	1.962-10	2.625	4.719	EY 5-4-5121X
1	1710	1.964-10	2.625	4.500	EY 6-4-2211 Chamfered Counterbore
1	1710	1.962-10	2.625	6.125	EY 6-4-4151 Chamfered Counterbore; High angle yoke
1	1710	1.962-10	2.625	6.125	EY 6-4-4151-1 Chamfered Counterbore; High angle yoke
1	1710	1.962-10	2.625	4.500	EY 6-4-4721 Chamfered Counterbore
1	1710	1.962-10	2.625	4.500	EY 6-4-4731-1X Chamfered Counterbore
1	1710	1.962-10	2.625	4.500	EY 6-4-4731X Chamfered Counterbore
1	1710	1.962-10	2.625	6.125	EY 6-4-4851-1X Chamfered Counterbore; High angle yoke
1	1710	1.962-10	2.625	6.125	EY 6-4-4851X Chamfered Counterbore; High angle yoke
1	1710	1.962-10	2.625	5.250	EY 6-4-5151X Chamfered Counterbore
1	1760	1.964-10	2.625	5.625	EY 6.3-4-221X Chamfered Counterbore
1	1810	1.964-10	2.625	5.625	EY 6.5-4-2351X Chamfered Counterbore
2	1410	1.750-10	2.625	4.250	EY 3-4-2511-1 .250 deep spline chamfer
2	1480	1.750-10	2.625	4.281	EY 3-4-5791-1X .250 deep spline chamfer; C'bore depth is chamfered
2	1550	1.750-10	2.625	4.672	EY 4-4-3581-1X .250 deep spline chamfer
2	1610	1.750-10	2.625	6.000	EY 5-4-4761X High angle yoke
2	1610	1.750-10	2.625	4.750	EY 5-4-5111X
2	1710	1.750-10	2.625	5.250	EY 6-4-4301X Chamfered Counterbore

Pos	Series	Spline Data	Hub Dia	* to End of Hub	End Fitting Part Number
42R (Continued)					
2	1710	1.750-10	2.625	6.125	EY 6-4-4861X Chamfered Counterbore; High angle yoke
2	1710	1.750-10	2.625	4.500	EY 6-4-5581-1X Chamfered Counterbore
2	1710	1.750-10	2.625	4.500	EY 6-4-5581X Chamfered Counterbore
3	1410	1.750-10	2.625	4.250	EY 3-4-2511-1 All ratios except 3.70 & 4.11; .250 deep spline chamfer
3	1480	1.750-10	2.625	4.281	EY 3-4-5791-1X .250 deep spline chamfer; C'bore depth is chamfered
3	1550	1.750-10	2.625	4.672	EY 4-4-3581-1X .250 deep spline chamfer
3	1610	1.750-10	2.625	6.000	EY 5-4-4761X All ratios except 3.70 & 4.11; High angle yoke
3	1610	1.962-10	2.625	6.000	EY 5-4-4771X 3.70 & 4.11 ratios only; High angle yoke
3	1610	1.750-10	2.625	4.750	EY 5-4-5111X All ratios except 3.70 & 4.11
3	1610	1.962-10	2.625	4.719	EY 5-4-5121X
3	1710	1.962-10	2.625	6.125	EY 6-4-4151 Chamfered Counterbore; High angle yoke
3	1710	1.962-10	2.625	6.125	EY 6-4-4151-1 Chamfered Counterbore; High angle yoke
3	1710	1.750-10	2.625	5.250	EY 6-4-4301X All ratios except 3.70 & 4.11; Chamfered Counterbore
3	1710	1.962-10	2.625	6.125	EY 6-4-4851-1X 3.70 & 4.11 ratios only; Chamfered Counterbore; High angle yoke
3	1710	1.962-10	2.625	6.125	EY 6-4-4851X 3.70 & 4.11 ratios only; Chamfered Counterbore; High angle yoke
3	1710	1.750-10	2.625	6.125	EY 6-4-4861X All ratios except 3.70 & 4.11; Chamfered Counterbore; High angle yoke
3	1710	1.962-10	2.625	5.250	EY 6-4-5151X 3.70 & 4.11 ratios only; Chamfered Counterbore
3	1710	1.750-10	2.625	4.500	EY 6-4-5581-1X All ratios except 3.70 & 4.11; Chamfered Counterbore

44-DP					
1	1610	2.422-18	3.375	6.125	EY 5-4-5491-1X
1	1710	2.422-18	3.375	5.250	EY 6-4-3161
1	1710	2.422-18	3.375	5.812	EY 6-4-4581
1	1710	2.422-18	3.375	5.812	EY 6-4-4581-1
1	1710	2.422-18	3.375	5.812	EY 6-4-4751-1X
1	1710	2.422-18	3.375	5.812	EY 6-4-4751X
1	1760	2.422-18	3.375	6.000	EY 6.3-4-241-1X
1	1760	2.422-18	3.375	6.000	EY 6.3-4-241X
1	1810	2.422-18	3.375	5.812	EY 6.5-4-1991
1	1810	2.422-18	3.375	5.812	EY 6.5-4-1991-1
1	1810	2.422-18	3.375	5.812	EY 6.5-4-2361-1X
1	1810	2.422-18	3.375	5.812	EY 6.5-4-2361X
2	1610	2.149-16	2.938	6.250	EY 5-4-5161-1X
2	1610	2.149-16	2.938	6.250	EY 5-4-5161X High angle yoke
2	1610	2.149-16	2.938	6.500	EY 5-4-5511X High angle yoke
2	1710	2.149-16	2.938	5.500	EY 6-4-4171-1X
2	1710	2.149-16	2.938	5.500	EY 6-4-4171X
2	1710	2.149-16	2.938	6.625	EY 6-4-4591 High angle yoke
2	1710	2.149-16	2.938	6.625	EY 6-4-5481X High angle yoke

Continued on next page

*C/L to End of Hub for EY (End Yoke); Flange Face to End of Hub for CF (Companion Flange)

■ Hub machined for speedometer gear



Important: See Safety Information in General Information Section (J300P-GI)

TANDEM AXLES

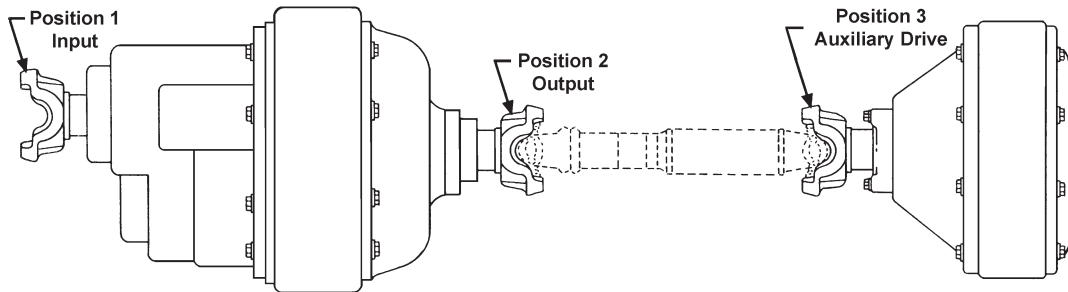

Pos	Series	Spline Data	Hub Dia	* to End of Hub	End Fitting Part Number
-----	--------	-------------	---------	-----------------	-------------------------

44-DP (Continued)

2	1760	2.149-16	2.938	5.812	EY 6.3-4-141-1
2	1760	2.149-16	2.938	5.812	EY 6.3-4-251-1X
2	1760	2.149-16	2.938	5.812	EY 6.3-4-251X
2	1810	2.149-16	2.938	5.812	EY 6.5-4-2291
2	1810	2.149-16	2.938	5.812	EY 6.5-4-2291-1
2	1810	2.149-16	2.938	5.812	EY 6.5-4-2401-1X
2	1810	2.149-16	2.938	5.812	EY 6.5-4-2401X
3	1610	2.149-16	2.938	6.250	EY 5-4-5161-1X
3	1610	2.149-16	2.938	6.250	EY 5-4-5161X <i>High angle yoke</i>
3	1610	2.149-16	2.938	6.500	EY 5-4-5511X <i>High angle yoke</i>
3	1710	2.149-16	2.938	5.500	EY 6-4-4171-1X
3	1710	2.149-16	2.938	5.500	EY 6-4-4171X
3	1710	2.149-16	2.938	6.625	EY 6-4-5481X <i>High angle yoke</i>
3	1710	2.149-16	2.938	6.625	EY 6-4-9841-1X <i>High angle yoke</i>
3	1710	2.149-16	2.938	6.625	EY 6-4-9841X <i>High angle yoke</i>
3	1760	2.149-16	2.938	5.812	EY 6.3-4-141-1
3	1760	2.149-16	2.938	5.812	EY 6.3-4-251-1X
3	1760	2.149-16	2.938	5.812	EY 6.3-4-251X
3	1810	2.149-16	2.938	5.812	EY 6.5-4-2291
3	1810	2.149-16	2.938	5.812	EY 6.5-4-2291-1
3	1810	2.149-16	2.938	5.812	EY 6.5-4-2401-1X
3	1810	2.149-16	2.938	5.812	EY 6.5-4-2401X

44-DS

1	1610	2.422-18	3.375	6.125	EY 5-4-5491-1X
1	1710	2.422-18	3.375	5.250	EY 6-4-3161
1	1710	2.422-18	3.375	5.812	EY 6-4-4581
1	1710	2.422-18	3.375	5.812	EY 6-4-4581-1
1	1710	2.422-18	3.375	5.812	EY 6-4-4751-1X
1	1710	2.422-18	3.375	5.812	EY 6-4-4751X
1	1760	2.422-18	3.375	6.000	EY 6.3-4-241-1X
1	1760	2.422-18	3.375	6.000	EY 6.3-4-241X
1	1810	2.422-18	3.375	5.812	EY 6.5-4-1991
1	1810	2.422-18	3.375	5.812	EY 6.5-4-1991-1
1	1810	2.422-18	3.375	5.812	EY 6.5-4-2361-1X
1	1810	2.422-18	3.375	5.812	EY 6.5-4-2361X
2	1610	2.149-16	2.938	6.250	EY 5-4-5161-1X
2	1610	2.149-16	2.938	6.250	EY 5-4-5161X <i>High angle yoke</i>
2	1610	2.149-16	2.938	6.500	EY 5-4-5511X <i>High angle yoke</i>
2	1710	2.149-16	2.938	5.500	EY 6-4-4171-1X
2	1710	2.149-16	2.938	5.500	EY 6-4-4171X
2	1710	2.149-16	2.938	6.625	EY 6-4-4591 <i>High angle yoke</i>

Pos	Series	Spline Data	Hub Dia	* to End of Hub	End Fitting Part Number
-----	--------	-------------	---------	-----------------	-------------------------

44-DS (Continued)

2	1710	2.149-16	2.938	6.625	EY 6-4-5481X <i>High angle yoke</i>
2	1760	2.149-16	2.938	5.812	EY 6.3-4-141-1
2	1760	2.149-16	2.938	5.812	EY 6.3-4-251-1X
2	1760	2.149-16	2.938	5.812	EY 6.3-4-251X
2	1810	2.149-16	2.938	5.812	EY 6.5-4-2291
2	1810	2.149-16	2.938	5.812	EY 6.5-4-2291-1
2	1810	2.149-16	2.938	5.812	EY 6.5-4-2401-1X
2	1810	2.149-16	2.938	5.812	EY 6.5-4-2401X
3	1610	2.149-16	2.938	6.250	EY 5-4-5161-1X
3	1610	2.149-16	2.938	6.250	EY 5-4-5161X <i>High angle yoke</i>
3	1610	2.149-16	2.938	6.500	EY 5-4-5511X <i>High angle yoke</i>
3	1710	2.149-16	2.938	5.500	EY 6-4-4171-1X
3	1710	2.149-16	2.938	5.500	EY 6-4-4171X
3	1710	2.149-16	2.938	6.625	EY 6-4-5481X <i>High angle yoke</i>
3	1760	2.149-16	2.938	5.812	EY 6.3-4-141-1
3	1760	2.149-16	2.938	5.812	EY 6.3-4-251-1X
3	1760	2.149-16	2.938	5.812	EY 6.3-4-251X
3	1810	2.149-16	2.938	5.812	EY 6.5-4-2291
3	1810	2.149-16	2.938	5.812	EY 6.5-4-2291-1
3	1810	2.149-16	2.938	5.812	EY 6.5-4-2401-1X
3	1810	2.149-16	2.938	5.812	EY 6.5-4-2401X

44-DT, 44-RP, 44-RS

1	1610	2.422-18	3.375	6.125	EY 5-4-5491-1X
1	1710	2.422-18	3.375	5.250	EY 6-4-3161
1	1710	2.422-18	3.375	5.812	EY 6-4-4581
1	1710	2.422-18	3.375	5.812	EY 6-4-4581-1
1	1710	2.422-18	3.375	5.812	EY 6-4-4751-1X
1	1710	2.422-18	3.375	5.812	EY 6-4-4751X
1	1760	2.422-18	3.375	6.000	EY 6.3-4-241-1X
1	1760	2.422-18	3.375	6.000	EY 6.3-4-241X
1	1810	2.422-18	3.375	5.812	EY 6.5-4-1991
1	1810	2.422-18	3.375	5.812	EY 6.5-4-1991-1
1	1810	2.422-18	3.375	5.812	EY 6.5-4-2361-1X
2	1610	2.149-16	2.938	6.250	EY 5-4-5161-1X
2	1610	2.149-16	2.938	6.250	EY 5-4-5161X <i>High angle yoke</i>
2	1610	2.149-16	2.938	6.500	EY 5-4-5511X <i>High angle yoke</i>
2	1710	2.149-16	2.938	5.500	EY 6-4-4171-1X
2	1710	2.149-16	2.938	5.500	EY 6-4-4171X
2	1710	2.149-16	2.938	6.625	EY 6-4-4591 <i>High angle yoke</i>
2	1710	2.149-16	2.938	6.625	EY 6-4-5481X <i>High angle yoke</i>

*C/L to End of Hub for EY (End Yoke); Flange Face to End of Hub for CF (Companion Flange)

■ Hub machined for speedometer gear



Pos	Series	Spline Data	Hub Dia	* to End of Hub	End Fitting Part Number
44-DT, 44-RP, 44-RS (Continued)					
2	1760	2.149-16	2.938	5.812	EY 6.3-4-141-1
2	1760	2.149-16	2.938	5.812	EY 6.3-4-251-1X
2	1760	2.149-16	2.938	5.812	EY 6.3-4-251X
2	1810	2.149-16	2.938	5.812	EY 6.5-4-2291
2	1810	2.149-16	2.938	5.812	EY 6.5-4-2291-1
2	1810	2.149-16	2.938	5.812	EY 6.5-4-2401-1X
2	1810	2.149-16	2.938	5.812	EY 6.5-4-2401X
3	1610	2.149-16	2.938	6.250	EY 5-4-5161-1X
3	1610	2.149-16	2.938	6.250	EY 5-4-5161X
					<i>High angle yoke</i>
3	1610	2.149-16	2.938	6.500	EY 5-4-5511X
					<i>High angle yoke</i>
3	1710	2.149-16	2.938	5.500	EY 6-4-4171-1X
3	1710	2.149-16	2.938	5.500	EY 6-4-4171X
3	1710	2.149-16	2.938	6.625	EY 6-4-5481X
					<i>High angle yoke</i>
3	1760	2.149-16	2.938	5.812	EY 6.3-4-141-1
3	1760	2.149-16	2.938	5.812	EY 6.3-4-251-1X
3	1760	2.149-16	2.938	5.812	EY 6.3-4-251X
3	1810	2.149-16	2.938	5.812	EY 6.5-4-2291
3	1810	2.149-16	2.938	5.812	EY 6.5-4-2291-1
3	1810	2.149-16	2.938	5.812	EY 6.5-4-2401-1X
3	1810	2.149-16	2.938	5.812	EY 6.5-4-2401X

45-MR					
2	1550	1.962-10	2.625	4.266	EY 4-4-4071-1X
2	1610	1.962-10	2.625	5.312	EY 5-4-4471-1
2	1710	1.962-10	2.625	4.500	EY 6-4-4731X
					<i>Chamfered Counterbore</i>
2	1710	1.962-10	2.625	6.125	EY 6-4-4851X
					<i>Chamfered Counterbore; High angle yoke</i>
2	1810	1.964-10	2.625	5.625	EY 6.5-4-2351X
					<i>Chamfered Counterbore</i>
3	1550	1.962-10	2.625	4.266	EY 4-4-4071-1X
3	1610	1.962-10	2.625	5.312	EY 5-4-4471-1
3	1710	1.962-10	2.625	4.500	EY 6-4-4731X
					<i>Chamfered Counterbore</i>
3	1710	1.962-10	2.625	6.125	EY 6-4-4851X
					<i>Chamfered Counterbore; High angle yoke</i>
3	1810	1.964-10	2.625	5.625	EY 6.5-4-2351X
					<i>Chamfered Counterbore</i>

50D					
1	1550	1.962-10	2.625	4.266	EY 4-4-4071-1X
1	1610	1.962-10	2.625	5.312	EY 5-4-4471-1
1	1610	1.962-10	2.625	6.000	EY 5-4-4771X
					<i>High angle yoke</i>
1	1610	1.962-10	2.625	4.719	EY 5-4-5121X
1	1610	2.274-44	2.938	5.000	EY 5-4-6381-1X
1	1610	2.274-44	2.938	5.000	EY 5-4-6381X
1	1710	1.964-10	2.625	4.500	EY 6-4-2211
					<i>Chamfered Counterbore</i>
1	1710	1.962-10	2.625	4.500	EY 6-4-4731-1X
					<i>Chamfered Counterbore</i>
1	1710	1.962-10	2.625	4.500	EY 6-4-4731X
					<i>Chamfered Counterbore</i>
1	1710	1.962-10	2.625	6.125	EY 6-4-4851-1X
					<i>Chamfered Counterbore; High angle yoke</i>
1	1710	1.962-10	2.625	6.125	EY 6-4-4851X
					<i>Chamfered Counterbore; High angle yoke</i>
1	1710	2.149-16	2.938	5.188	EY 6-4-4961
1	1710	2.149-16	2.938	5.188	EY 6-4-5061X
1	1710	1.962-10	2.625	5.250	EY 6-4-5151X
					<i>Chamfered Counterbore</i>

Pos	Series	Spline Data	Hub Dia	* to End of Hub	End Fitting Part Number
50D (Continued)					
1	1710	2.274-44	2.938	5.188	EY 6-4-6041-1X
1	1710	2.274-44	2.938	5.188	EY 6-4-6041X
1	1760	1.964-10	2.625	5.625	EY 6.3-4-221X
					<i>Chamfered Counterbore</i>
1	1760	2.149-16	2.938	5.250	EY 6.3-4-231X
1	1760	2.274-44	2.938	5.250	EY 6.3-4-331-1X
1	1760	2.274-44	2.938	5.250	EY 6.3-4-331X
1	1810	1.964-10	2.625	5.625	EY 6.5-4-2351X
					<i>Chamfered Counterbore</i>
1	1810	2.274-44	2.938	5.250	EY 6.5-4-3281-1X
1	1810	2.274-44	2.938	5.250	EY 6.5-4-3281X
2	1410	1.750-10	2.625	4.250	EY 3-4-2511-1
					<i>.250 deep spline chamfer</i>
2	1480	1.750-10	2.625	4.281	EY 3-4-5791-1X
					<i>.250 deep spline chamfer; C'bore depth is chamfered</i>
2	1550	1.750-10	2.625	4.672	EY 4-4-3581-1X
					<i>.250 deep spline chamfer</i>
2	1610	1.750-10	2.625	6.000	EY 5-4-4761X
					<i>High angle yoke</i>
2	1610	1.962-10	2.625	6.000	EY 5-4-4771X
					<i>High angle yoke</i>
2	1610	1.750-10	2.625	4.750	EY 5-4-5111X
2	1610	1.790-34	2.625	4.938	EY 5-4-6341
2	1610	1.790-34	2.625	6.188	EY 5-4-6351
					<i>High angle yoke</i>
2	1710	1.750-10	2.625	5.250	EY 6-4-4301X
					<i>Chamfered Counterbore</i>
2	1710	1.962-10	2.625	6.125	EY 6-4-4851X
					<i>Chamfered Counterbore; High angle yoke</i>
2	1710	1.750-10	2.625	6.125	EY 6-4-4861X
					<i>Chamfered Counterbore; High angle yoke</i>
2	1710	1.962-10	2.625	5.250	EY 6-4-5151X
					<i>Chamfered Counterbore</i>
2	1710	1.750-10	2.625	4.500	EY 6-4-5581-1X
					<i>Chamfered Counterbore</i>
2	1710	1.750-10	2.625	4.500	EY 6-4-5581X
					<i>Chamfered Counterbore</i>
2	1710	1.790-34	2.625	6.312	EY 6-4-6451
					<i>High angle yoke</i>
2	1710	1.790-34	2.625	5.438	EY 6-4-6481
3	1410	1.750-10	2.625	4.250	EY 3-4-2511-1
					<i>All ratios except 3.70 & 4.11; .250 deep spline chamfer</i>
3	1480	1.750-10	2.625	4.281	EY 3-4-5791-1X
					<i>.250 deep spline chamfer; C'bore depth is chamfered</i>
3	1550	1.750-10	2.625	4.672	EY 4-4-3581-1X
					<i>.250 deep spline chamfer</i>
3	1610	1.750-10	2.625	6.000	EY 5-4-4761X
					<i>All ratios except 3.70 & 4.11; High angle yoke</i>
3	1610	1.962-10	2.625	6.000	EY 5-4-4771X
					<i>3.70 & 4.11 ratios only; High angle yoke</i>
3	1610	1.750-10	2.625	4.750	EY 5-4-5111X
					<i>All ratios except 3.70 & 4.11</i>
3	1610	1.962-10	2.625	4.719	EY 5-4-5121X
					<i>3.70 & 4.11 ratios only</i>
3	1710	1.962-10	2.625	6.125	EY 6-4-4151-1
					<i>Chamfered Counterbore; High angle yoke</i>
3	1710	1.750-10	2.625	5.250	EY 6-4-4301X
					<i>All ratios except 3.70 & 4.11; Chamfered Counterbore</i>
3	1710	1.962-10	2.625	6.125	EY 6-4-4851-1X
					<i>3.70 & 4.11 ratios only; Chamfered Counterbore; High angle yoke</i>
3	1710	1.962-10	2.625	6.125	EY 6-4-4851X
					<i>3.70 & 4.11 ratios only; Chamfered Counterbore; High angle yoke</i>

Continued on next page

*C/L to End of Hub for EY (End Yoke); Flange Face to End of Hub for CF (Companion Flange)

■ Hub machined for speedometer gear



Important: See Safety Information in General Information Section (J300P-GI)

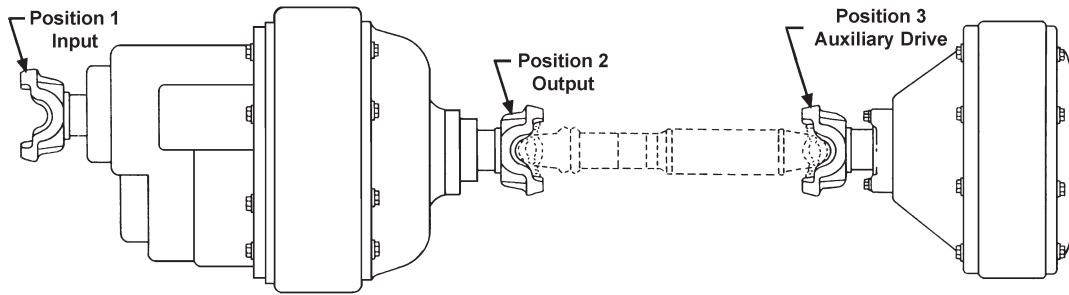

Pos	Series	Spline Data	Hub Dia	* to End of Hub	End Fitting Part Number
-----	--------	-------------	---------	-----------------	-------------------------

50D (Continued)

3	1710	1.750-10	2.625	6.125	EY 6-4-4861X
<i>All ratios except 3.70 & 4.11; Chamfered Counterbore; High angle yoke</i>					
3	1710	1.962-10	2.625	5.250	EY 6-4-5141
<i>Chamfered Counterbore</i>					
3	1710	1.962-10	2.625	5.250	EY 6-4-5151X
<i>3.70 & 4.11 ratios only; Chamfered Counterbore</i>					
3	1710	1.750-10	2.625	4.500	EY 6-4-5581-1X
<i>All ratios except 3.70 & 4.11; Chamfered Counterbore</i>					
3	1710	1.750-10	2.625	4.500	EY 6-4-5581X
<i>All ratios except 3.70 & 4.11; Chamfered Counterbore</i>					

50R

1	1610	2.274-44	2.938	5.000	EY 5-4-6381-1X
1	1610	2.274-44	2.938	5.000	EY 5-4-6381X
1	1710	2.149-16	2.938	5.188	EY 6-4-5061X
1	1710	2.274-44	2.938	5.188	EY 6-4-6041-1X
1	1710	2.274-44	2.938	5.188	EY 6-4-6041X
1	1760	2.149-16	2.938	5.250	EY 6-3-4-231X
1	1760	2.274-44	2.938	5.250	EY 6-3-4-331-1X
1	1760	2.274-44	2.938	5.250	EY 6-3-4-331X
1	1810	2.274-44	2.938	5.250	EY 6-5-4-3281-1X
1	1810	2.274-44	2.938	5.250	EY 6-5-4-3281X
2	1610	1.962-10	2.625	6.000	EY 5-4-4771X
<i>High angle yoke</i>					
2	1610	1.790-34	2.625	4.938	EY 5-4-6341
2	1610	1.790-34	2.625	6.188	EY 5-4-6351
<i>High angle yoke</i>					
2	1710	1.962-10	2.625	6.125	EY 6-4-4851X
<i>Chamfered Counterbore; High angle yoke</i>					
2	1710	1.962-10	2.625	5.250	EY 6-4-5151X
<i>Chamfered Counterbore</i>					
2	1710	1.790-34	2.625	6.312	EY 6-4-6451
<i>High angle yoke</i>					
2	1710	1.790-34	2.625	5.438	EY 6-4-6481
3	1610	1.750-10	2.625	6.000	EY 5-4-4761X
<i>High angle yoke</i>					
3	1610	2.024-39	2.625	6.000	EY 5-4-5971X
<i>High angle yoke</i>					
3	1610	2.024-39	2.625	5.312	EY 5-4-5991X
3	1710	1.750-10	2.625	5.250	EY 6-4-4301X
<i>Chamfered Counterbore</i>					
3	1710	1.750-10	2.625	6.125	EY 6-4-4861X
<i>Chamfered Counterbore; High angle yoke</i>					
3	1710	2.024-39	2.625	5.250	EY 6-4-6001X
<i>Chamfered Counterbore</i>					
3	1710	2.024-39	2.625	6.125	EY 6-4-6021X
<i>High angle yoke; Chamfered Counterbore</i>					

280

3	1710	1.962-10	2.625	6.125	EY 6-4-4851-1X
<i>Chamfered Counterbore; High angle yoke</i>					

Pos	Series	Spline Data	Hub Dia	* to End of Hub	End Fitting Part Number
-----	--------	-------------	---------	-----------------	-------------------------

340

1	1550	1.962-10	2.625	4.266	EY 4-4-4071-1X
1	1610	1.962-10	2.625	5.312	EY 5-4-4471-1
1	1610	1.962-10	2.625	6.000	EY 5-4-4771X
<i>High angle yoke</i>					
1	1610	1.962-10	2.625	4.719	EY 5-4-5121X
1	1710	1.964-10	2.625	4.500	EY 6-4-2211
<i>Chamfered Counterbore</i>					
1	1710	1.962-10	2.625	4.500	EY 6-4-4731-1X
<i>Chamfered Counterbore</i>					
1	1710	1.962-10	2.625	4.500	EY 6-4-4731X
<i>Chamfered Counterbore</i>					
1	1710	1.962-10	2.625	6.125	EY 6-4-4851-1X
<i>Chamfered Counterbore; High angle yoke</i>					
1	1710	1.962-10	2.625	6.125	EY 6-4-4851X
<i>Chamfered Counterbore; High angle yoke</i>					
1	1710	2.149-16	2.938	5.188	EY 6-4-4961
1	1710	2.149-16	2.938	5.188	EY 6-4-5061X
1	1710	1.962-10	2.625	5.250	EY 6-4-5151X
<i>Chamfered Counterbore</i>					
1	1710	2.114-32	3.000	4.562	EY 6-4-5811
1	1710	2.114-32	3.000	4.562	EY 6-4-7221X
1	1710	2.274-44	2.938	5.188	EY 6-4-8551X
1	1760	2.274-44	2.938	5.250	EY 6-3-4-1481X
1	1760	2.114-32	3.000	5.000	EY 6-3-4-1511-1
1	1760	2.114-32	3.000	5.000	EY 6-3-4-1521-1X
1	1760	1.964-10	2.625	5.625	EY 6-3-4-221X
<i>Chamfered Counterbore</i>					
1	1760	2.149-16	2.938	5.250	EY 6-3-4-231X
1	1810	1.964-10	2.625	5.625	EY 6-5-4-2351X
<i>Chamfered Counterbore</i>					
1	1810	2.274-44	2.938	5.250	EY 6-5-4-4351X
1	1810	2.114-32	3.000	5.000	EY 6-5-4-4451-1
1	1810	2.114-32	3.000	5.000	EY 6-5-4-4461-1X
2	1410	1.750-10	2.625	4.250	EY 3-4-2511-1
<i>.250 deep spline chamfer</i>					
2	1480	1.750-10	2.625	4.281	EY 3-4-5791-1X
<i>.250 deep spline chamfer; C'bore depth is chamfered</i>					
2	1550	1.750-10	2.625	4.672	EY 4-4-3581-1X
<i>.250 deep spline chamfer</i>					
2	1610	1.750-10	2.625	6.000	EY 5-4-4761X
<i>High angle yoke</i>					
2	1610	1.962-10	2.625	6.000	EY 5-4-4771X
<i>High angle yoke</i>					
2	1610	1.750-10	2.625	4.750	EY 5-4-5111X
2	1610	1.790-34	2.625	6.188	EY 5-4-8441X
<i>High angle yoke</i>					
2	1710	1.750-10	2.625	5.250	EY 6-4-4301X
<i>Chamfered Counterbore</i>					
2	1710	1.962-10	2.625	6.125	EY 6-4-4851X
<i>Chamfered Counterbore; High angle yoke</i>					
2	1710	1.750-10	2.625	6.125	EY 6-4-4861X
<i>Chamfered Counterbore; High angle yoke</i>					

*C/L to End of Hub for EY (End Yoke); Flange Face to End of Hub for CF (Companion Flange)

■ Hub machined for speedometer gear



Pos	Series	Spline Data	Hub Dia	* to End of Hub	End Fitting Part Number
340 (Continued)					
2	1710	1.962-10	2.625	5.250	EY 6-4-5151X <i>Chamfered Counterbore</i>
2	1710	1.750-10	2.625	4.500	EY 6-4-5581-1X <i>Chamfered Counterbore</i>
2	1710	1.750-10	2.625	4.500	EY 6-4-5581X <i>Chamfered Counterbore</i>
2	1710	1.790-34	2.625	5.438	EY 6-4-8511X
2	1710	1.790-34	2.625	6.312	EY 6-4-8521X <i>High angle yoke</i>
3	1410	1.750-10	2.625	4.250	EY 3-4-2511-1 <i>All ratios except 3.70 & 4.11; .250 deep spline chamfer</i>
3	1480	1.750-10	2.625	4.281	EY 3-4-5791-1X <i>.250 deep spline chamfer; C'bore depth is chamfered</i>
3	1550	1.750-10	2.625	4.672	EY 4-4-3581-1X <i>.250 deep spline chamfer</i>
3	1610	1.750-10	2.625	6.000	EY 5-4-4761X <i>All ratios except 3.70 & 4.11; High angle yoke</i>
3	1610	1.962-10	2.625	6.000	EY 5-4-4771X <i>3.70 & 4.11 ratios only; High angle yoke</i>
3	1610	1.750-10	2.625	4.750	EY 5-4-5111X <i>All ratios except 3.70 & 4.11</i>
3	1610	1.962-10	2.625	4.719	EY 5-4-5121X <i>3.70 & 4.11 ratios only</i>
3	1610	2.024-39	2.625	4.719	EY 5-4-8131-1X
3	1610	2.024-39	2.625	5.312	EY 5-4-8411X
3	1610	2.024-39	2.625	6.000	EY 5-4-8421X <i>High angle yoke</i>
3	1710	1.962-10	2.625	6.125	EY 6-4-4151-1 <i>Chamfered Counterbore; High angle yoke</i>
3	1710	1.750-10	2.625	5.250	EY 6-4-4301X <i>All ratios except 3.70 & 4.11; Chamfered Counterbore</i>
3	1710	1.962-10	2.625	6.125	EY 6-4-4851-1X <i>3.70 & 4.11 ratios only; Chamfered Counterbore; High angle yoke</i>
3	1710	1.962-10	2.625	6.125	EY 6-4-4851X <i>3.70 & 4.11 ratios only; Chamfered Counterbore; High angle yoke</i>
3	1710	1.750-10	2.625	6.125	EY 6-4-4861X <i>All ratios except 3.70 & 4.11; Chamfered Counterbore; High angle yoke</i>
3	1710	1.962-10	2.625	5.250	EY 6-4-5141 <i>Chamfered Counterbore</i>
3	1710	1.962-10	2.625	5.250	EY 6-4-5151X <i>3.70 & 4.11 ratios only; Chamfered Counterbore</i>
3	1710	1.750-10	2.625	4.500	EY 6-4-5581-1X <i>All ratios except 3.70 & 4.11; Chamfered Counterbore</i>
3	1710	1.750-10	2.625	4.500	EY 6-4-5581X <i>All ratios except 3.70 & 4.11; Chamfered Counterbore</i>
3	1710	2.024-39	2.625	5.250	EY 6-4-8531X
3	1710	2.024-39	2.625	6.125	EY 6-4-8541X <i>High angle yoke</i>

341					
1	1810	2.274-44	2.938	3.094	CF 6.5-1-2391
1	1810	2.274-44	2.938	3.094	CF 6.5-1-2401X
1	SPL170	2.274-44	2.938	5.281	EY 170-4-101-1X
1	SPL170	2.274-44	2.938	5.281	EY 170-4-91-1
1	SPL250	2.274-44	2.938	5.484	EY 250-4-51-1
1	SPL250	2.274-44	2.938	5.484	EY 250-4-61-1X
1	1610	2.274-44	2.938	5.000	EY 5-4-6381-1X
1	1610	2.274-44	2.938	5.000	EY 5-4-6381X
1	1610	2.274-44	2.938	5.000	EY 5-4-8321-1
1	1610	2.274-44	2.938	5.000	EY 5-4-8431-1X
1	1710	2.274-44	2.938	5.188	EY 6-4-6041-1X
1	1710	2.274-44	2.938	5.188	EY 6-4-6041X
1	1710	2.274-44	2.938	5.188	EY 6-4-8461

Pos	Series	Spline Data	Hub Dia	* to End of Hub	End Fitting Part Number
341 (Continued)					
1	1710	2.274-44	2.938	5.188	EY 6-4-8461-1
1	1710	2.274-44	2.938	5.188	EY 6-4-8551-1X
1	1710	2.274-44	2.938	5.188	EY 6-4-8551X
1	1760	2.274-44	2.938	5.250	EY 6.3-4-1421
1	1760	2.274-44	2.938	5.250	EY 6.3-4-1421-1
1	1760	2.274-44	2.938	5.250	EY 6.3-4-1481-1X
1	1760	2.274-44	2.938	5.250	EY 6.3-4-1481X
1	1760	2.274-44	2.938	5.250	EY 6.3-4-331-1X
1	1760	2.274-44	2.938	5.250	EY 6.3-4-331X
1	1810	2.274-44	2.938	5.250	EY 6.5-4-3281-1X
1	1810	2.274-44	2.938	5.250	EY 6.5-4-3281X
1	1810	2.274-44	2.938	5.250	EY 6.5-4-4321
1	1810	2.274-44	2.938	5.250	EY 6.5-4-4321-1
1	1810	2.274-44	2.938	5.250	EY 6.5-4-4351-1X
1	1810	2.274-44	2.938	5.250	EY 6.5-4-4351X
2	SPL170	1.790-34	2.625	5.600	EY 170-4-111-1
2	SPL170	1.790-34	2.625	5.600	EY 170-4-121-1X
2	SPL170	1.790-34	2.625	6.250	EY 170-4-131-1 <i>High angle yoke</i>
2	SPL170	1.790-34	2.625	6.250	EY 170-4-141-1X <i>High angle yoke</i>
2	1610	1.790-34	2.625	4.938	EY 5-4-6341
2	1610	1.790-34	2.625	6.188	EY 5-4-6351 <i>High angle yoke</i>
2	1610	1.790-34	2.625	6.188	EY 5-4-8001 <i>High angle yoke</i>
2	1610	1.790-34	2.625	6.188	EY 5-4-8441X <i>High angle yoke</i>
2	1610	1.790-34	2.625	4.938	EY 5-4-8491-1
2	1610	1.790-34	2.625	4.938	EY 5-4-8501-1X
2	1710	1.790-34	2.625	6.312	EY 6-4-6451 <i>High angle yoke</i>
2	1710	1.790-34	2.625	6.312	EY 6-4-6451-1 <i>High angle yoke</i>
2	1710	1.790-34	2.625	5.438	EY 6-4-6481
2	1710	1.790-34	2.625	6.312	EY 6-4-8001 <i>High angle yoke</i>
2	1710	1.790-34	2.625	6.312	EY 6-4-8001-1 <i>High angle yoke</i>
2	1710	1.790-34	2.625	5.438	EY 6-4-8081
2	1710	1.790-34	2.625	5.438	EY 6-4-8081-1
2	1710	1.790-34	2.625	6.312	EY 6-4-8521-1X <i>High angle yoke</i>
2	1710	1.790-34	2.625	6.312	EY 6-4-8521X <i>High angle yoke</i>
3	SPL140	2.024-39	2.625	5.030	EY 140-4-551-1 <i>Counterbore at hub end.</i>
3	SPL140	2.024-39	2.625	5.030	EY 140-4-561-1X <i>Counterbore at hub end.</i>
3	SPL170	2.024-39	2.625	4.938	EY 170-4-151-1
3	SPL170	2.024-39	2.625	4.938	EY 170-4-161-1X
3	SPL170	2.024-39	2.625	6.016	EY 170-4-171-1 <i>High angle yoke</i>
3	SPL170	2.024-39	2.625	6.016	EY 170-4-181-1X <i>High angle yoke</i>
3	1480	2.024-39	2.625	4.344	EY 3-4-13051-1
3	1480	2.024-39	2.625	4.344	EY 3-4-13061-1X
3	1550	2.024-39	2.625	4.266	EY 4-4-6471-1
3	1550	2.024-39	2.625	4.266	EY 4-4-7551-1X
3	1610	2.024-39	2.625	6.000	EY 5-4-5971X <i>High angle yoke</i>

Continued on next page

*C/L to End of Hub for EY (End Yoke); Flange Face to End of Hub for CF (Companion Flange)

■ Hub machined for speedometer gear



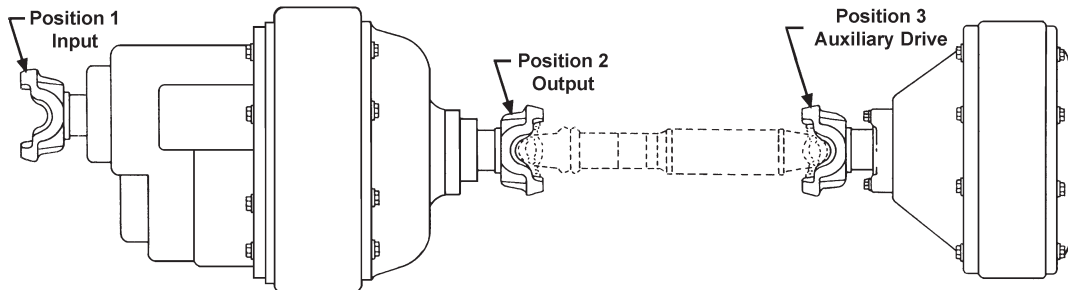

Pos	Series	Spline Data	Hub Dia	* to End of Hub	End Fitting Part Number
-----	--------	-------------	---------	-----------------	-------------------------

341 (Continued)

3	1610	2.024-39	2.625	5.312	EY 5-4-5991X
3	1610	2.024-39	2.625	5.312	EY 5-4-7971
3	1610	2.024-39	2.625	5.312	EY 5-4-7971-1
3	1610	2.024-39	2.625	4.719	EY 5-4-7981
3	1610	2.024-39	2.625	6.000	EY 5-4-7991 <i>High angle yoke</i>
3	1610	2.024-39	2.625	4.719	EY 5-4-8131X
3	1610	2.024-39	2.625	6.000	EY 5-4-8421X <i>High angle yoke</i>
3	1710	2.024-39	2.625	5.250	EY 6-4-6001X <i>Chamfered Counterbore</i>
3	1710	2.024-39	2.625	6.125	EY 6-4-6021-1X <i>High angle yoke; Chamfered Counterbore</i>
3	1710	2.024-39	2.625	6.125	EY 6-4-6021X <i>High angle yoke; Chamfered Counterbore</i>
3	1710	2.024-39	2.625	6.125	EY 6-4-7981 <i>High angle yoke</i>
3	1710	2.024-39	2.625	6.125	EY 6-4-7981-1 <i>High angle yoke</i>
3	1710	2.024-39	2.625	5.250	EY 6-4-7991
3	1710	2.024-39	2.625	5.250	EY 6-4-7991-1
3	1710	2.024-39	2.625	5.250	EY 6-4-8231-1X
3	1710	2.024-39	2.625	6.125	EY 6-4-8541-1X <i>High angle yoke</i>
3	1710	2.024-39	2.625	6.125	EY 6-4-8541X <i>High angle yoke</i>

344

1	SPL140	2.274-44	3.000	5.160	EY 140-4-1261-1
1	SPL140	2.274-44	3.000	5.160	EY 140-4-1271-1X
1	SPL140	2.274-44	3.000	5.160	EY 140-4-321-1
1	SPL140	2.274-44	3.000	5.160	EY 140-4-331-1X
1	SPL170	2.274-44	3.000	5.270	EY 170-4-1671-1X <i>Counterbore at hub end.</i>
1	SPL170	2.274-44	3.000	5.270	EY 170-4-191-1
1	SPL170	2.274-44	3.000	5.270	EY 170-4-201-1X
1	SPL250	2.274-44	3.000	5.490	EY 250-4-71-1
1	SPL250	2.274-44	3.000	5.490	EY 250-4-81-1X
1	1610	2.274-44	3.000	5.000	EY 5-4-8311-1
1	1610	2.274-44	3.000	5.000	EY 5-4-9261-1X
1	1710	2.274-44	3.000	5.190	EY 6-4-8451
1	1710	2.274-44	3.000	5.190	EY 6-4-8451-1
1	1710	2.274-44	3.000	5.190	EY 6-4-8981-1X
1	1710	2.274-44	3.000	5.190	EY 6-4-8981X
1	1760	2.274-44	3.000	5.250	EY 6.3-4-1411
1	1760	2.274-44	3.000	5.250	EY 6.3-4-1411-1
1	1760	2.274-44	3.000	5.250	EY 6.3-4-5221-1X
1	1760	2.274-44	3.000	5.250	EY 6.3-4-5221X
1	1810	2.274-44	3.000	5.250	EY 6.5-4-4311
1	1810	2.274-44	3.000	5.250	EY 6.5-4-4311-1

Pos	Series	Spline Data	Hub Dia	* to End of Hub	End Fitting Part Number
-----	--------	-------------	---------	-----------------	-------------------------

344 (Continued)

1	1810	2.274-44	3.000	5.250	EY 6.5-4-4571-1X
1	1810	2.274-44	3.000	5.250	EY 6.5-4-4571X
2	SPL170	2.024-39	2.625	6.500	EY 170-4-1651-1X
2	SPL170	2.024-39	2.625	5.270	EY 170-4-211-1 <i>High angle yoke</i>
2	SPL170	2.024-39	2.625	5.266	EY 170-4-221-1X
2	SPL170	2.024-39	2.625	6.500	EY 170-4-231-1 <i>High angle yoke</i>
2	SPL170	2.024-39	2.625	6.500	EY 170-4-241-1X <i>High angle yoke</i>
2	SPL170	2.024-39	2.625	5.750	EY 5001768
2	SPL170	2.024-39	2.625	5.750	EY 5008578
2	1610	2.024-39	2.625	6.000	EY 5-4-8301 <i>High angle yoke</i>
2	1610	2.024-39	2.625	6.000	EY 5-4-9271X <i>High angle yoke</i>
2	1710	2.024-39	2.625	6.125	EY 6-4-8431
2	1710	2.024-39	2.625	6.125	EY 6-4-8431-1
2	1710	2.024-39	2.625	5.250	EY 6-4-8441
2	1710	2.024-39	2.625	5.250	EY 6-4-8441-1
2	1710	2.024-39	2.625	6.125	EY 6-4-9001-1X
2	1710	2.024-39	2.625	6.125	EY 6-4-9001X
2	1710	2.024-39	2.625	5.250	EY 6-4-9041-1X
2	1710	2.024-39	2.625	5.250	EY 6-4-9041X
3	SPL140	2.024-39	3.000	4.940	EY 140-4-1151-1
3	SPL140	2.024-39	3.000	4.940	EY 140-4-1161-1X
3	SPL140	2.024-39	3.000	4.940	EY 140-4-361-1
3	SPL140	2.024-39	3.000	4.940	EY 140-4-371-1X
3	SPL170	2.024-39	3.000	5.540	EY 170-4-08577-1X
3	SPL170	2.024-39	3.000	6.240	EY 170-4-1621-1
3	SPL170	2.024-39	3.000	6.240	EY 170-4-1631-1X
3	SPL170	2.024-39	2.625	6.500	EY 170-4-1641-1
3	SPL170	2.274-44	3.000	5.270	EY 170-4-1661-1 <i>Counterbore at hub end.</i>
3	SPL170	2.024-39	3.000	5.156	EY 170-4-251-1 <i>High angle yoke</i>
3	SPL170	2.024-39	3.000	5.156	EY 170-4-261-1X
3	SPL170	2.024-39	3.000	6.240	EY 170-4-271-1 <i>High angle yoke</i>
3	SPL170	2.024-39	3.000	6.240	EY 170-4-281-1X <i>High angle yoke</i>
3	SPL170	2.024-39	3.000	5.540	EY 5001766
3	SPL170	2.024-39	3.000	5.540	EY 5008577
3	SPL90	2.024-39	3.000	4.750	EY 90-4-241-1
3	SPL90	2.024-39	3.000	4.750	EY 90-4-251-1X
3	1480	2.024-39	3.000	4.344	EY 3-4-13071-1
3	1480	2.024-39	3.000	4.344	EY 3-4-13081-1X
3	1550	2.024-39	3.000	4.281	EY 4-4-7561-1
3	1550	2.024-39	3.000	4.281	EY 4-4-7571-1X

*C/L to End of Hub for EY (End Yoke); Flange Face to End of Hub for CF (Companion Flange)

■ Hub machined for speedometer gear



Pos	Series	Spline Data	Hub Dia	* to End of Hub	End Fitting Part Number
344 (Continued)					
3	1610	2.024-39	3.000	6.000	EY 5-4-8261 <i>High angle yoke</i>
3	1610	2.024-39	3.000	6.000	EY 5-4-8261-1 <i>High angle yoke</i>
3	1610	2.024-39	3.000	4.875	EY 5-4-9221-1
3	1610	2.024-39	3.000	4.875	EY 5-4-9231-1X
3	1610	2.024-39	3.000	6.000	EY 5-4-9241-1X <i>High angle yoke</i>
3	1610	2.024-39	3.000	6.000	EY 5-4-9241X <i>High angle yoke</i>
3	1710	2.024-39	3.000	6.125	EY 6-4-8411 <i>High angle yoke</i>
3	1710	2.024-39	3.000	6.125	EY 6-4-8411-1 <i>High angle yoke</i>
3	1710	2.024-39	3.000	5.250	EY 6-4-8421
3	1710	2.024-39	3.000	5.250	EY 6-4-8421-1
3	1710	2.024-39	3.000	6.125	EY 6-4-8991-1X <i>High angle yoke</i>
3	1710	2.024-39	3.000	6.125	EY 6-4-8991X <i>High angle yoke</i>
3	1710	2.024-39	3.000	5.250	EY 6-4-9031-1X
3	1710	2.024-39	3.000	5.250	EY 6-4-9031X
5	SPL170	2.024-39	2.625	5.750	EY 170-4-08578-1X
355					
1	SPL140	2.274-44	3.000	5.160	EY 140-4-321-1
1	SPL140	2.274-44	3.000	5.160	EY 140-4-331-1X
380					
1	1550	1.962-10	2.625	4.266	EY 4-4-4071-1X
1	1610	1.962-10	2.625	5.312	EY 5-4-4471-1
1	1610	1.962-10	2.625	6.000	EY 5-4-4771X <i>High angle yoke</i>
1	1610	1.962-10	2.625	4.719	EY 5-4-5121X
1	1710	1.964-10	2.625	4.500	EY 6-4-2211 <i>Chamfered Counterbore</i>
1	1710	1.962-10	2.625	6.125	EY 6-4-4151 <i>Chamfered Counterbore; High angle yoke</i>
1	1710	1.962-10	2.625	6.125	EY 6-4-4151-1 <i>Chamfered Counterbore; High angle yoke</i>
1	1710	1.962-10	2.625	4.500	EY 6-4-4721 <i>Chamfered Counterbore</i>
1	1710	1.962-10	2.625	4.500	EY 6-4-4731-1X <i>Chamfered Counterbore</i>
1	1710	1.962-10	2.625	4.500	EY 6-4-4731X <i>Chamfered Counterbore</i>
1	1710	1.962-10	2.625	6.125	EY 6-4-4851-1X <i>Chamfered Counterbore</i>
1	1710	1.962-10	2.625	6.125	EY 6-4-4851X <i>Chamfered Counterbore; High angle yoke</i>
1	1710	2.149-16	2.938	5.188	EY 6-4-4961
1	1710	2.149-16	2.938	5.188	EY 6-4-5061X
1	1710	1.962-10	2.625	5.250	EY 6-4-5151X <i>Chamfered Counterbore</i>
1	1710	2.114-32	3.000	4.562	EY 6-4-5811
1	1710	2.114-32	3.000	4.562	EY 6-4-7221X
1	1710	2.274-44	2.938	5.188	EY 6-4-8551X
1	1760	2.274-44	2.938	5.250	EY 6.3-4-1481X
1	1760	2.114-32	3.000	5.000	EY 6.3-4-1511-1
1	1760	2.114-32	3.000	5.000	EY 6.3-4-1521-1X
1	1760	1.964-10	2.625	5.625	EY 6.3-4-221X <i>Chamfered Counterbore</i>
1	1760	2.149-16	2.938	5.250	EY 6.3-4-231X

Pos	Series	Spline Data	Hub Dia	* to End of Hub	End Fitting Part Number
380 (Continued)					
1	1810	1.964-10	2.625	5.625	EY 6.5-4-2351X <i>Chamfered Counterbore</i>
1	1810	2.274-44	2.938	5.250	EY 6.5-4-4351X
1	1810	2.114-32	3.000	5.000	EY 6.5-4-4451-1
1	1810	2.114-32	3.000	5.000	EY 6.5-4-4461-1X
2	1410	1.750-10	2.625	4.250	EY 3-4-2511-1 <i>.250 deep spline chamfer</i>
2	1480	1.750-10	2.625	4.281	EY 3-4-5791-1X <i>.250 deep spline chamfer; C'bore depth is chamfered</i>
2	1550	1.750-10	2.625	4.672	EY 4-4-3581-1X <i>.250 deep spline chamfer</i>
2	1610	1.750-10	2.625	6.000	EY 5-4-4761X <i>High angle yoke</i>
2	1610	1.962-10	2.625	6.000	EY 5-4-4771X <i>High angle yoke</i>
2	1610	1.750-10	2.625	4.750	EY 5-4-5111X
2	1610	1.790-34	2.625	6.188	EY 5-4-8441X <i>High angle yoke</i>
2	1710	1.750-10	2.625	5.250	EY 6-4-4301X <i>Chamfered Counterbore</i>
2	1710	1.962-10	2.625	6.125	EY 6-4-4851X <i>Chamfered Counterbore; High angle yoke</i>
2	1710	1.750-10	2.625	6.125	EY 6-4-4861X <i>Chamfered Counterbore; High angle yoke</i>
2	1710	1.962-10	2.625	5.250	EY 6-4-5151X <i>Chamfered Counterbore</i>
2	1710	1.750-10	2.625	4.500	EY 6-4-5581-1X <i>Chamfered Counterbore</i>
2	1710	1.750-10	2.625	4.500	EY 6-4-5581X <i>Chamfered Counterbore</i>
2	1710	1.790-34	2.625	5.438	EY 6-4-8511X
2	1710	1.790-34	2.625	6.312	EY 6-4-8521X <i>High angle yoke</i>
3	1410	1.750-10	2.625	4.250	EY 3-4-2511-1 <i>All ratios except 3.70 & 4.11; .250 deep spline chamfer</i>
3	1480	1.750-10	2.625	4.281	EY 3-4-5791-1X <i>.250 deep spline chamfer; C'bore depth is chamfered</i>
3	1550	1.750-10	2.625	4.672	EY 4-4-3581-1X <i>.250 deep spline chamfer</i>
3	1610	1.750-10	2.625	6.000	EY 5-4-4761X <i>All ratios except 3.70 & 4.11; High angle yoke</i>
3	1610	1.962-10	2.625	6.000	EY 5-4-4771X <i>3.70 & 4.11 ratios only; High angle yoke</i>
3	1610	1.750-10	2.625	4.750	EY 5-4-5111X <i>All ratios except 3.70 & 4.11</i>
3	1610	1.962-10	2.625	4.719	EY 5-4-5121X <i>3.70 & 4.11 ratios only</i>
3	1610	2.024-39	2.625	4.719	EY 5-4-8131-1X
3	1610	2.024-39	2.625	5.312	EY 5-4-8411X
3	1610	2.024-39	2.625	6.000	EY 5-4-8421X <i>High angle yoke</i>
3	1710	1.962-10	2.625	6.125	EY 6-4-4151 <i>Chamfered Counterbore; High angle yoke</i>
3	1710	1.962-10	2.625	6.125	EY 6-4-4151-1 <i>Chamfered Counterbore; High angle yoke</i>
3	1710	1.750-10	2.625	5.250	EY 6-4-4301X <i>All ratios except 3.70 & 4.11; Chamfered Counterbore</i>
3	1710	1.962-10	2.625	6.125	EY 6-4-4851-1X <i>3.70 & 4.11 ratios only; Chamfered Counterbore; High angle yoke</i>
3	1710	1.962-10	2.625	6.125	EY 6-4-4851X <i>3.70 & 4.11 ratios only; Chamfered Counterbore; High angle yoke</i>
3	1710	1.750-10	2.625	6.125	EY 6-4-4861X <i>All ratios except 3.70 & 4.11; Chamfered Counterbore; High angle yoke</i>

Continued on next page

*C/L to End of Hub for EY (End Yoke); Flange Face to End of Hub for CF (Companion Flange)

■ Hub machined for speedometer gear



Important: See Safety Information in General Information Section (J300P-GI)

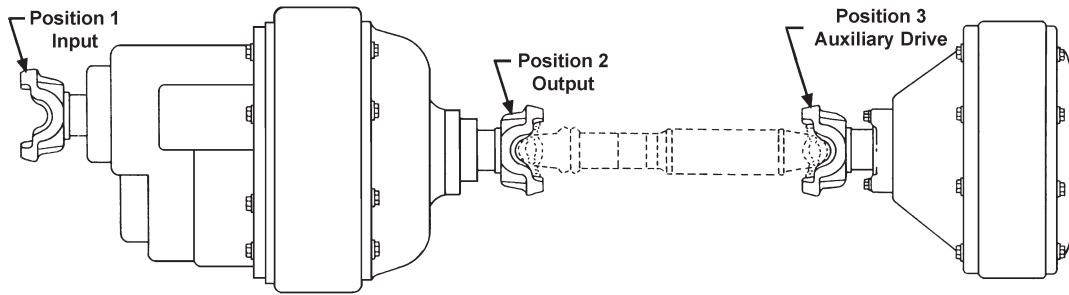

Pos	Series	Spline Data	Hub Dia	* to End of Hub	End Fitting Part Number
-----	--------	-------------	---------	-----------------	-------------------------

380 (Continued)

3	1710	1.962-10	2.625	5.250	EY 6-4-5141 <i>Chamfered Counterbore</i>
3	1710	1.962-10	2.625	5.250	EY 6-4-5151X <i>3.70 & 4.11 ratios only; Chamfered Counterbore</i>
3	1710	1.750-10	2.625	4.500	EY 6-4-5581-1X <i>All ratios except 3.70 & 4.11; Chamfered Counterbore</i>
3	1710	1.750-10	2.625	4.500	EY 6-4-5581X <i>All ratios except 3.70 & 4.11; Chamfered Counterbore</i>
3	1710	2.024-39	2.625	5.250	EY 6-4-8531X
3	1710	2.024-39	2.625	6.125	EY 6-4-8541X <i>High angle yoke</i>

381

1	1810	2.274-44	2.938	3.094	CF 6.5-1-2401X
1	1610	2.274-44	2.938	5.000	EY 5-4-6381-1X
1	1610	2.274-44	2.938	5.000	EY 5-4-6381X
1	1610	2.274-44	2.938	5.000	EY 5-4-8431-1X
1	1710	2.274-44	2.938	5.188	EY 6-4-6041-1X
1	1710	2.274-44	2.938	5.188	EY 6-4-6041X
1	1710	2.274-44	2.938	5.188	EY 6-4-8461
1	1710	2.274-44	2.938	5.188	EY 6-4-8461-1
1	1710	2.274-44	2.938	5.188	EY 6-4-8551-1X
1	1710	2.274-44	2.938	5.188	EY 6-4-8551X
1	1760	2.274-44	2.938	5.250	EY 6.3-4-1421
1	1760	2.274-44	2.938	5.250	EY 6.3-4-1421-1
1	1760	2.274-44	2.938	5.250	EY 6.3-4-1481-1X
1	1760	2.274-44	2.938	5.250	EY 6.3-4-331-1X
1	1760	2.274-44	2.938	5.250	EY 6.3-4-331X
1	1810	2.274-44	2.938	5.250	EY 6.5-4-3281-1X
1	1810	2.274-44	2.938	5.250	EY 6.5-4-3281X
1	1810	2.274-44	2.938	5.250	EY 6.5-4-4351-1X
1	1810	2.274-44	2.938	5.250	EY 6.5-4-4351X
2	1610	1.790-34	2.625	4.938	EY 5-4-6341
2	1610	1.790-34	2.625	6.188	EY 5-4-6351 <i>High angle yoke</i>
2	1610	1.790-34	2.625	6.188	EY 5-4-8441X <i>High angle yoke</i>
2	1610	1.790-34	2.625	4.938	EY 5-4-8501-1X
2	1710	1.790-34	2.625	6.312	EY 6-4-6451 <i>High angle yoke</i>
2	1710	1.790-34	2.625	5.438	EY 6-4-6481
2	1710	1.790-34	2.625	5.438	EY 6-4-8081
2	1710	1.790-34	2.625	5.438	EY 6-4-8081-1
2	1710	1.790-34	2.625	5.438	EY 6-4-8511-1X
2	1710	1.790-34	2.625	5.438	EY 6-4-8511X
2	1710	1.790-34	2.625	6.312	EY 6-4-8521-1X <i>High angle yoke</i>
2	1710	1.790-34	2.625	6.312	EY 6-4-8521X <i>High angle yoke</i>

Pos	Series	Spline Data	Hub Dia	* to End of Hub	End Fitting Part Number
-----	--------	-------------	---------	-----------------	-------------------------

381 (Continued)

3	1610	2.024-39	2.625	6.000	EY 5-4-5971X <i>High angle yoke</i>
3	1610	2.024-39	2.625	5.312	EY 5-4-5991X
3	1610	2.024-39	2.625	4.719	EY 5-4-7981
3	1610	2.024-39	2.625	4.719	EY 5-4-8131X
3	1610	2.024-39	2.625	5.312	EY 5-4-8411-1X
3	1610	2.024-39	2.625	5.312	EY 5-4-8411X
3	1610	2.024-39	2.625	6.000	EY 5-4-8421X <i>High angle yoke</i>
3	1710	2.024-39	2.625	5.250	EY 6-4-6001X <i>Chamfered Counterbore</i>
3	1710	2.024-39	2.625	6.125	EY 6-4-6021-1X <i>High angle yoke; Chamfered Counterbore</i>
3	1710	2.024-39	2.625	6.125	EY 6-4-6021X <i>High angle yoke; Chamfered Counterbore</i>
3	1710	2.024-39	2.625	6.125	EY 6-4-7981 <i>High angle yoke</i>
3	1710	2.024-39	2.625	6.125	EY 6-4-7981-1 <i>High angle yoke</i>
3	1710	2.024-39	2.625	5.250	EY 6-4-7991
3	1710	2.024-39	2.625	5.250	EY 6-4-8231-1X
3	1710	2.024-39	2.625	5.250	EY 6-4-8531X
3	1710	2.024-39	2.625	6.125	EY 6-4-8541-1X <i>High angle yoke</i>
3	1710	2.024-39	2.625	6.125	EY 6-4-8541X <i>High angle yoke</i>

400

1	1710	2.149-16	2.938	5.188	EY 6-4-4961
1	1710	2.149-16	2.938	5.188	EY 6-4-5061X
1	1710	2.274-44	2.938	5.188	EY 6-4-8551X
1	1760	2.274-44	2.938	5.250	EY 6.3-4-1481X
1	1760	2.149-16	2.938	5.250	EY 6.3-4-231X
1	1810	2.274-44	2.938	5.250	EY 6.5-4-4351X
2	1610	1.962-10	2.625	6.000	EY 5-4-4771X <i>High angle yoke</i>
2	1610	1.790-34	2.625	6.188	EY 5-4-8441X <i>High angle yoke</i>
2	1610	2.024-39	3.000	5.594	EY 5-4-9351-1
2	1710	1.962-10	2.625	6.125	EY 6-4-4851X <i>Chamfered Counterbore; High angle yoke</i>
2	1710	1.962-10	2.625	5.250	EY 6-4-5151X <i>Chamfered Counterbore</i>
2	1710	1.790-34	2.625	5.438	EY 6-4-8511X
2	1710	1.790-34	2.625	6.312	EY 6-4-8521X <i>High angle yoke</i>
3	1610	1.750-10	2.625	6.000	EY 5-4-4761X <i>High angle yoke</i>
3	1610	2.024-39	2.625	6.000	EY 5-4-5971X <i>High angle yoke</i>
3	1610	2.024-39	2.625	5.312	EY 5-4-5991X

*C/L to End of Hub for EY (End Yoke); Flange Face to End of Hub for CF (Companion Flange)

■ Hub machined for speedometer gear



Pos	Series	Spline Data	Hub Dia	* to End of Hub	End Fitting Part Number
400 (Continued)					
3	1610	2.024-39	2.625	4.719	EY 5-4-8131-1X
3	1610	2.024-39	2.625	5.312	EY 5-4-8411X
3	1610	2.024-39	2.625	6.000	EY 5-4-8421X <i>High angle yoke</i>
3	1710	1.750-10	2.625	5.250	EY 6-4-4301X <i>Chamfered Counterbore</i>
3	1710	1.750-10	2.625	6.125	EY 6-4-4861X <i>Chamfered Counterbore; High angle yoke</i>
3	1710	2.024-39	2.625	5.250	EY 6-4-6001X <i>Chamfered Counterbore</i>
3	1710	2.024-39	2.625	5.250	EY 6-4-8531X
3	1710	2.024-39	2.625	6.125	EY 6-4-8541X <i>High angle yoke</i>
401					
1	1810	2.274-44	2.938	3.094	CF 6.5-1-2401X
1	1610	2.274-44	2.938	5.000	EY 5-4-6381-1X
1	1610	2.274-44	2.938	5.000	EY 5-4-6381X
1	1610	2.274-44	2.938	5.000	EY 5-4-8431-1X
1	1710	2.274-44	2.938	5.188	EY 6-4-6041-1X
1	1710	2.274-44	2.938	5.188	EY 6-4-6041X
1	1710	2.114-32	3.000	4.562	EY 6-4-7221X
1	1710	2.274-44	2.938	5.188	EY 6-4-8461
1	1710	2.274-44	2.938	5.188	EY 6-4-8461-1
1	1710	2.274-44	2.938	5.188	EY 6-4-8551-1X
1	1710	2.274-44	2.938	5.188	EY 6-4-8551X
1	1760	2.274-44	2.938	5.250	EY 6.3-4-1421
1	1760	2.274-44	2.938	5.250	EY 6.3-4-1421-1
1	1760	2.274-44	2.938	5.250	EY 6.3-4-1481-1X
1	1760	2.274-44	2.938	5.250	EY 6.3-4-1481X
1	1760	2.114-32	3.000	5.000	EY 6.3-4-1511-1
1	1760	2.114-32	3.000	5.000	EY 6.3-4-1521-1X
1	1760	2.274-44	2.938	5.250	EY 6.3-4-331-1X
1	1760	2.274-44	2.938	5.250	EY 6.3-4-331X
1	1810	2.274-44	2.938	5.250	EY 6.5-4-3281-1X
1	1810	2.274-44	2.938	5.250	EY 6.5-4-3281X
1	1810	2.274-44	2.938	5.250	EY 6.5-4-4351-1X
1	1810	2.274-44	2.938	5.250	EY 6.5-4-4351X
1	1810	2.114-32	3.000	5.000	EY 6.5-4-4451-1
1	1810	2.114-32	3.000	5.000	EY 6.5-4-4461-1X
2	1610	1.790-34	2.625	4.938	EY 5-4-6341
2	1610	1.790-34	2.625	6.188	EY 5-4-6351 <i>High angle yoke</i>
2	1610	1.790-34	2.625	6.188	EY 5-4-8441X <i>High angle yoke</i>
2	1610	1.790-34	2.625	4.938	EY 5-4-8501-1X
2	1710	1.790-34	2.625	6.312	EY 6-4-6451 <i>High angle yoke</i>
2	1710	1.790-34	2.625	5.438	EY 6-4-6481
2	1710	1.790-34	2.625	5.438	EY 6-4-8081
2	1710	1.790-34	2.625	5.438	EY 6-4-8081-1
2	1710	1.790-34	2.625	5.438	EY 6-4-8511-1X
2	1710	1.790-34	2.625	5.438	EY 6-4-8511X
2	1710	1.790-34	2.625	6.312	EY 6-4-8521-1X <i>High angle yoke</i>
2	1710	1.790-34	2.625	6.312	EY 6-4-8521X <i>High angle yoke</i>
3	1610	2.024-39	2.625	6.000	EY 5-4-5971X <i>High angle yoke</i>
3	1610	2.024-39	2.625	5.312	EY 5-4-5991X
3	1610	2.024-39	2.625	4.719	EY 5-4-7981

Pos	Series	Spline Data	Hub Dia	* to End of Hub	End Fitting Part Number
401 (Continued)					
3	1610	2.024-39	2.625	4.719	EY 5-4-8131X
3	1610	2.024-39	2.625	5.312	EY 5-4-8411-1X
3	1610	2.024-39	2.625	5.312	EY 5-4-8411X
3	1610	2.024-39	2.625	6.000	EY 5-4-8421X
3	1710	2.024-39	2.625	5.250	EY 6-4-6001X <i>Chamfered Counterbore</i>
3	1710	2.024-39	2.625	6.125	EY 6-4-6021-1X <i>High angle yoke; Chamfered Counterbore</i>
3	1710	2.024-39	2.625	6.125	EY 6-4-6021X <i>High angle yoke; Chamfered Counterbore</i>
3	1710	2.024-39	2.625	6.125	EY 6-4-7981 <i>High angle yoke</i>
3	1710	2.024-39	2.625	6.125	EY 6-4-7981-1 <i>High angle yoke</i>
3	1710	2.024-39	2.625	5.250	EY 6-4-7991
3	1710	2.024-39	2.625	5.250	EY 6-4-8231-1X
3	1710	2.024-39	2.625	5.250	EY 6-4-8531X
3	1710	2.024-39	2.625	6.125	EY 6-4-8541-1X <i>High angle yoke</i>
3	1710	2.024-39	2.625	6.125	EY 6-4-8541X <i>High angle yoke</i>
402					
1	1810	2.274-44	2.938	3.094	CF 6.5-1-2391
1	SPL170	2.274-44	2.938	5.281	EY 170-4-101-1X
1	SPL170	2.274-44	2.938	5.281	EY 170-4-91-1
1	SPL250	2.274-44	2.938	5.484	EY 250-4-51-1
1	SPL250	2.274-44	2.938	5.484	EY 250-4-61-1X
1	1610	2.274-44	2.938	5.000	EY 5-4-6381-1X
1	1610	2.274-44	2.938	5.000	EY 5-4-6381X
1	1610	2.274-44	2.938	5.000	EY 5-4-8321-1
1	1610	2.274-44	2.938	5.000	EY 5-4-8431-1X
1	1710	2.274-44	2.938	5.188	EY 6-4-6041-1X
1	1710	2.274-44	2.938	5.188	EY 6-4-6041X
1	1710	2.274-44	2.938	5.188	EY 6-4-8461
1	1710	2.274-44	2.938	5.188	EY 6-4-8461-1
1	1710	2.274-44	2.938	5.188	EY 6-4-8551-1X
1	1710	2.274-44	2.938	5.188	EY 6-4-8551X
1	1760	2.274-44	2.938	5.250	EY 6.3-4-1421
1	1760	2.274-44	2.938	5.250	EY 6.3-4-1421-1
1	1760	2.274-44	2.938	5.250	EY 6.3-4-1481-1X
1	1760	2.274-44	2.938	5.250	EY 6.3-4-1481X
1	1760	2.274-44	2.938	5.250	EY 6.3-4-331-1X
1	1760	2.274-44	2.938	5.250	EY 6.3-4-331X
1	1810	2.274-44	2.938	5.250	EY 6.5-4-3281-1X
1	1810	2.274-44	2.938	5.250	EY 6.5-4-3281X
1	1810	2.274-44	2.938	5.250	EY 6.5-4-4321
1	1810	2.274-44	2.938	5.250	EY 6.5-4-4321-1
1	1810	2.274-44	2.938	5.250	EY 6.5-4-4351-1X
1	1810	2.274-44	2.938	5.250	EY 6.5-4-4351X
2	SPL170	1.790-34	2.625	5.600	EY 170-4-111-1
2	SPL170	1.790-34	2.625	5.600	EY 170-4-121-1X
2	SPL170	1.790-34	2.625	6.250	EY 170-4-131-1 <i>High angle yoke</i>
2	SPL170	1.790-34	2.625	6.250	EY 170-4-141-1X <i>High angle yoke</i>
2	1610	1.790-34	2.625	4.938	EY 5-4-6341
2	1610	1.790-34	2.625	6.188	EY 5-4-6351 <i>High angle yoke</i>

Continued on next page

*C/L to End of Hub for EY (End Yoke); Flange Face to End of Hub for CF (Companion Flange)

■ Hub machined for speedometer gear



Important: See Safety Information in General Information Section (J300P-GI)

TANDEM AXLES

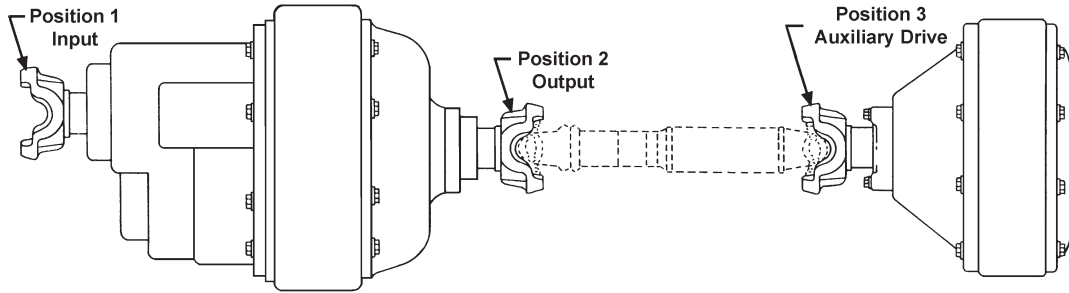

Pos	Series	Spline Data	Hub Dia	* to End of Hub	End Fitting Part Number
402 (Continued)					
2	1610	1.790-34	2.625	6.188	EY 5-4-8001 <i>High angle yoke</i>
2	1610	1.790-34	2.625	6.188	EY 5-4-8441X <i>High angle yoke</i>
2	1610	1.790-34	2.625	4.938	EY 5-4-8491-1
2	1610	1.790-34	2.625	4.938	EY 5-4-8501-1X
2	1710	1.790-34	2.625	6.312	EY 6-4-6451 <i>High angle yoke</i>
2	1710	1.790-34	2.625	6.312	EY 6-4-6451-1 <i>High angle yoke</i>
2	1710	1.790-34	2.625	5.438	EY 6-4-6481
2	1710	1.790-34	2.625	6.312	EY 6-4-8001 <i>High angle yoke</i>
2	1710	1.790-34	2.625	6.312	EY 6-4-8001-1 <i>High angle yoke</i>
2	1710	1.790-34	2.625	5.438	EY 6-4-8081
2	1710	1.790-34	2.625	5.438	EY 6-4-8081-1
2	1710	1.790-34	2.625	5.438	EY 6-4-8511-1X
2	1710	1.790-34	2.625	5.438	EY 6-4-8511X
2	1710	1.790-34	2.625	6.312	EY 6-4-8521-1X <i>High angle yoke</i>
3	SPL140	2.024-39	2.625	5.030	EY 140-4-551-1 <i>Counterbore at hub end.</i>
3	SPL140	2.024-39	2.625	5.030	EY 140-4-561-1X <i>Counterbore at hub end.</i>
3	SPL170	2.024-39	2.625	4.938	EY 170-4-151-1
3	SPL170	2.024-39	2.625	4.938	EY 170-4-161-1X
3	SPL170	2.024-39	2.625	6.016	EY 170-4-171-1 <i>High angle yoke</i>
3	SPL170	2.024-39	2.625	6.016	EY 170-4-181-1X <i>High angle yoke</i>
3	1480	2.024-39	2.625	4.344	EY 3-4-13051-1
3	1480	2.024-39	2.625	4.344	EY 3-4-13061-1X
3	1550	2.024-39	2.625	4.266	EY 4-4-6471-1
3	1550	2.024-39	2.625	4.266	EY 4-4-7551-1X
3	1610	2.024-39	2.625	6.000	EY 5-4-5971X <i>High angle yoke</i>
3	1610	2.024-39	2.625	5.312	EY 5-4-5991X
3	1610	2.024-39	2.625	5.312	EY 5-4-7971
3	1610	2.024-39	2.625	5.312	EY 5-4-7971-1
3	1610	2.024-39	2.625	4.719	EY 5-4-7981
3	1610	2.024-39	2.625	6.000	EY 5-4-7991 <i>High angle yoke</i>
3	1610	2.024-39	2.625	6.000	EY 5-4-8421X <i>High angle yoke</i>
3	1710	2.024-39	2.625	5.250	EY 6-4-6001X <i>Chamfered Counterbore</i>
3	1710	2.024-39	2.625	6.125	EY 6-4-6021X <i>High angle yoke; Chamfered Counterbore</i>
3	1710	2.024-39	2.625	6.125	EY 6-4-7981 <i>High angle yoke</i>

Pos	Series	Spline Data	Hub Dia	* to End of Hub	End Fitting Part Number
402 (Continued)					
3	1710	2.024-39	2.625	6.125	EY 6-4-7981-1 <i>High angle yoke</i>
3	1710	2.024-39	2.625	5.250	EY 6-4-7991
3	1710	2.024-39	2.625	5.250	EY 6-4-7991-1
3	1710	2.024-39	2.625	5.250	EY 6-4-8231-1X
3	1710	2.024-39	2.625	5.250	EY 6-4-8531-1X
3	1710	2.024-39	2.625	6.125	EY 6-4-8541-1X <i>High angle yoke</i>
3	1710	2.024-39	2.625	6.125	EY 6-4-8541X <i>High angle yoke</i>
403					
1	SPL170	2.274-44	2.938	5.281	EY 170-4-101-1X
1	SPL250	2.274-44	2.938	5.484	EY 250-4-61-1X
1	1610	2.274-44	2.938	5.000	EY 5-4-8431-1X
1	1710	2.274-44	2.938	5.188	EY 6-4-8551-1X
1	1710	2.274-44	2.938	5.188	EY 6-4-8551X
1	1760	2.274-44	2.938	5.250	EY 6.3-4-1481-1X
1	1760	2.274-44	2.938	5.250	EY 6.3-4-1481X
1	1810	2.274-44	2.938	5.250	EY 6.5-4-4351-1X
1	1810	2.274-44	2.938	5.250	EY 6.5-4-4351X
2	SPL170	1.790-34	2.625	5.600	EY 170-4-121-1X
2	SPL170	1.790-34	2.625	6.250	EY 170-4-141-1X <i>High angle yoke</i>
2	1610	1.790-34	2.625	6.188	EY 5-4-8441X <i>High angle yoke</i>
2	1710	1.790-34	2.625	5.438	EY 6-4-8511X
2	1710	1.790-34	2.625	6.312	EY 6-4-8521X <i>High angle yoke</i>
2	1710	2.274-44	3.000	5.190	EY 6-4-8981-1X
3	SPL170	2.024-39	2.625	4.938	EY 170-4-161-1X
3	SPL170	2.024-39	2.625	6.016	EY 170-4-181-1X <i>High angle yoke</i>
3	1550	2.024-39	2.625	4.266	EY 4-4-7551-1X
3	1610	2.024-39	2.625	4.719	EY 5-4-8131-1X
3	1610	2.024-39	2.625	5.312	EY 5-4-8411X
3	1710	2.024-39	2.625	5.250	EY 6-4-8531X
3	1710	2.024-39	2.625	6.125	EY 6-4-8541X <i>High angle yoke</i>
404					
1	SPL140	2.274-44	3.000	5.160	EY 140-4-1271-1X
1	SPL140	2.274-44	3.000	5.160	EY 140-4-331-1X
1	SPL170	2.274-44	3.000	5.270	EY 170-4-1671-1X <i>Counterbore at hub end.</i>
1	SPL170	2.274-44	3.000	5.270	EY 170-4-191-1
1	SPL170	2.274-44	3.000	5.270	EY 170-4-201-1X
1	SPL250	2.274-44	3.000	5.490	EY 250-4-71-1
1	SPL250	2.274-44	3.000	5.490	EY 250-4-81-1X
1	1610	2.274-44	3.000	5.000	EY 5-4-8311-1

*C/L to End of Hub for EY (End Yoke); Flange Face to End of Hub for CF (Companion Flange)

■ Hub machined for speedometer gear



Pos	Series	Spline Data	Hub Dia	* to End of Hub	End Fitting Part Number
404 (Continued)					
1	1610	2.274-44	3.000	5.000	EY 5-4-9261-1X
1	1710	2.274-44	3.000	5.190	EY 6-4-8451
1	1710	2.274-44	3.000	5.190	EY 6-4-8451-1
1	1710	2.274-44	3.000	5.190	EY 6-4-8981-1X
1	1710	2.274-44	3.000	5.190	EY 6-4-8981X
1	1760	2.274-44	3.000	5.250	EY 6.3-4-1411
1	1760	2.274-44	3.000	5.250	EY 6.3-4-1411-1
1	1760	2.274-44	3.000	5.250	EY 6.3-4-5221-1X
1	1760	2.274-44	3.000	5.250	EY 6.3-4-5221X
1	1810	2.274-44	3.000	5.250	EY 6.5-4-4311
1	1810	2.274-44	3.000	5.250	EY 6.5-4-4311-1
1	1810	2.274-44	3.000	5.250	EY 6.5-4-4571-1X
1	1810	2.274-44	3.000	5.250	EY 6.5-4-4571X
2	SPL140	2.024-39	3.000	4.940	EY 140-4-371-1X
2	SPL170	2.024-39	2.625	5.750	EY 170-4-08578-1X
2	SPL170	2.024-39	2.625	6.500	EY 170-4-1651-1X
2	SPL170	2.024-39	2.625	5.270	EY 170-4-211-1 <i>High angle yoke</i>
2	SPL170	2.024-39	2.625	5.266	EY 170-4-221-1X
2	SPL170	2.024-39	2.625	6.500	EY 170-4-231-1 <i>High angle yoke</i>
2	SPL170	2.024-39	2.625	6.500	EY 170-4-241-1X <i>High angle yoke</i>
2	SPL170	2.024-39	2.625	5.750	EY 5001768
2	SPL170	2.024-39	2.625	5.750	EY 5008578
2	1610	2.024-39	2.625	6.000	EY 5-4-8301 <i>High angle yoke</i>
2	1610	2.024-39	2.625	6.000	EY 5-4-9271X <i>High angle yoke</i>
2	1710	2.024-39	2.625	6.125	EY 6-4-8431
2	1710	2.024-39	2.625	6.125	EY 6-4-8431-1
2	1710	2.024-39	2.625	5.250	EY 6-4-8441
2	1710	2.024-39	2.625	5.250	EY 6-4-8441-1
2	1710	2.024-39	2.625	6.125	EY 6-4-9001-1X
2	1710	2.024-39	2.625	6.125	EY 6-4-9001X
2	1710	2.024-39	2.625	5.250	EY 6-4-9041-1X
2	1710	2.024-39	2.625	5.250	EY 6-4-9041X
3	SPL100	2.024-39	3.000	7.295	EY 100-4-1371-1X <i>Flanged yoke w/8 tapped holes in flange</i>
3	SPL140	2.024-39	3.000	4.940	EY 140-4-1161-1X
3	SPL140	2.274-44	3.000	5.160	EY 140-4-331-1X
3	SPL140	2.024-39	3.000	4.940	EY 140-4-371-1X
3	SPL170	2.024-39	3.000	5.540	EY 170-4-08577-1X
3	SPL170	2.024-39	3.000	6.240	EY 170-4-1621-1
3	SPL170	2.024-39	3.000	6.240	EY 170-4-1631-1X
3	SPL170	2.024-39	2.625	6.500	EY 170-4-1641-1
3	SPL170	2.274-44	3.000	5.270	EY 170-4-1661-1 <i>Counterbore at hub end.</i>
3	SPL170	2.274-44	3.000	5.270	EY 170-4-201-1X
3	SPL170	2.024-39	3.000	5.156	EY 170-4-251-1 <i>High angle yoke</i>
3	SPL170	2.024-39	3.000	5.156	EY 170-4-261-1X
3	SPL170	2.024-39	3.000	6.240	EY 170-4-271-1 <i>High angle yoke</i>
3	SPL170	2.024-39	3.000	6.240	EY 170-4-281-1X <i>High angle yoke</i>
3	SPL170	2.024-39	3.000	5.540	EY 5001766
3	SPL170	2.024-39	3.000	5.540	EY 5008577
3	SPL90	2.024-39	3.000	4.750	EY 90-4-241-1
3	SPL90	2.024-39	3.000	4.750	EY 90-4-251-1X

Pos	Series	Spline Data	Hub Dia	* to End of Hub	End Fitting Part Number
404 (Continued)					
3	1480	2.024-39	3.000	4.344	EY 3-4-13071-1
3	1480	2.024-39	3.000	4.344	EY 3-4-13081-1X
3	1550	2.024-39	3.000	4.281	EY 4-4-7561-1
3	1550	2.024-39	3.000	4.281	EY 4-4-7571-1X
3	1610	2.024-39	3.000	6.000	EY 5-4-8261 <i>High angle yoke</i>
3	1610	2.024-39	3.000	6.000	EY 5-4-8261-1 <i>High angle yoke</i>
3	1610	2.024-39	3.000	4.875	EY 5-4-9221-1
3	1610	2.024-39	3.000	4.875	EY 5-4-9231-1X
3	1610	2.024-39	3.000	6.000	EY 5-4-9241-1X <i>High angle yoke</i>
3	1610	2.024-39	3.000	6.000	EY 5-4-9241X <i>High angle yoke</i>
3	1710	2.024-39	3.000	6.125	EY 6-4-8411 <i>High angle yoke</i>
3	1710	2.024-39	3.000	6.125	EY 6-4-8411-1 <i>High angle yoke</i>
3	1710	2.024-39	3.000	5.250	EY 6-4-8421
3	1710	2.024-39	3.000	5.250	EY 6-4-8421-1
3	1710	2.024-39	3.000	6.125	EY 6-4-8991-1X <i>High angle yoke</i>
3	1710	2.024-39	3.000	6.125	EY 6-4-8991X <i>High angle yoke</i>
405					
1	SPL140	2.274-44	3.000	5.160	EY 140-4-1261-1
1	SPL140	2.274-44	3.000	5.160	EY 140-4-1271-1X
1	SPL140	2.274-44	3.000	5.160	EY 140-4-321-1
1	SPL140	2.274-44	3.000	5.160	EY 140-4-331-1X
1	SPL170	2.274-44	3.000	5.270	EY 170-4-201-1X
1	SPL250	2.274-44	3.000	5.490	EY 250-4-81-1X
1	1610	2.274-44	3.000	5.000	EY 5-4-9261-1X
1	1710	2.274-44	3.000	5.190	EY 6-4-8981-1X
1	1710	2.274-44	3.000	5.190	EY 6-4-8981X
1	1760	2.274-44	3.000	5.250	EY 6.3-4-5221-1X
1	1760	2.274-44	3.000	5.250	EY 6.3-4-5221X
1	1810	2.274-44	3.000	5.250	EY 6.5-4-4571-1X
1	1810	2.274-44	3.000	5.250	EY 6.5-4-4571X
2	SPL170	2.024-39	2.625	5.266	EY 170-4-221-1X
2	SPL170	2.024-39	2.625	6.500	EY 170-4-241-1X <i>High angle yoke</i>
2	1610	2.024-39	2.625	6.000	EY 5-4-9271X <i>High angle yoke</i>
2	1710	2.024-39	2.625	6.125	EY 6-4-8431
2	1710	2.024-39	2.625	6.125	EY 6-4-8431-1
2	1710	2.024-39	2.625	5.250	EY 6-4-8441
2	1710	2.024-39	2.625	5.250	EY 6-4-8441-1
2	1710	2.024-39	2.625	6.125	EY 6-4-9001-1X
2	1710	2.024-39	2.625	6.125	EY 6-4-9001X
2	1710	2.024-39	2.625	5.250	EY 6-4-9041-1X
2	1710	2.024-39	2.625	5.250	EY 6-4-9041X
3	SPL140	2.024-39	3.000	4.940	EY 140-4-361-1
3	SPL140	2.024-39	3.000	4.940	EY 140-4-371-1X
3	SPL170	2.274-44	3.000	5.270	EY 170-4-201-1X
3	SPL170	2.024-39	3.000	5.156	EY 170-4-261-1X
3	SPL170	2.024-39	3.000	6.240	EY 170-4-281-1X <i>High angle yoke</i>
3	SPL250	2.274-44	3.000	5.490	EY 250-4-81-1X
3	SPL90	2.024-39	3.000	4.750	EY 90-4-241-1

Continued on next page

*C/L to End of Hub for EY (End Yoke); Flange Face to End of Hub for CF (Companion Flange)

■ Hub machined for speedometer gear



Important: See Safety Information in General Information Section (J300P-GI)

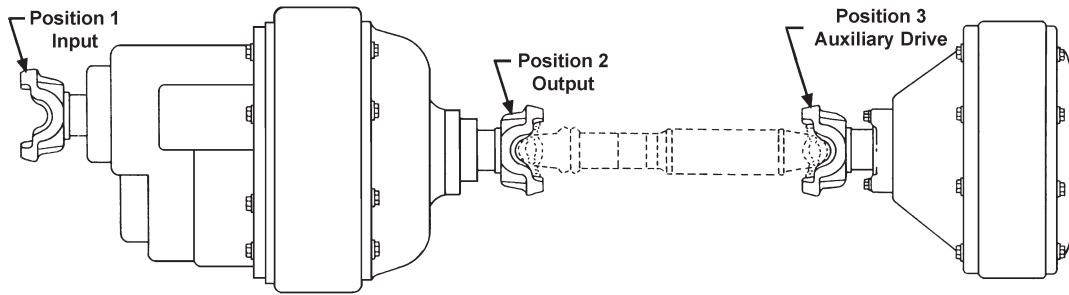

Pos	Series	Spline Data	Hub Dia	* to End of Hub	End Fitting Part Number
-----	--------	-------------	---------	-----------------	-------------------------

405 (Continued)

3	SPL90	2.024-39	3.000	4.750	EY 90-4-251-1X
3	1480	2.024-39	3.000	4.344	EY 3-4-13071-1
3	1480	2.024-39	3.000	4.344	EY 3-4-13081-1X
3	1550	2.024-39	3.000	4.281	EY 4-4-7561-1
3	1550	2.024-39	3.000	4.281	EY 4-4-7571-1X
3	1610	2.024-39	3.000	6.000	EY 5-4-8261 <i>High angle yoke</i>
3	1610	2.024-39	3.000	6.000	EY 5-4-8261-1 <i>High angle yoke</i>
3	1610	2.024-39	3.000	4.875	EY 5-4-9221-1
3	1610	2.024-39	3.000	4.875	EY 5-4-9231-1X
3	1610	2.024-39	3.000	6.000	EY 5-4-9241-1X <i>High angle yoke</i>
3	1610	2.024-39	3.000	6.000	EY 5-4-9241X <i>High angle yoke</i>
3	1710	2.024-39	3.000	6.125	EY 6-4-8411-1 <i>High angle yoke</i>
3	1710	2.024-39	3.000	5.250	EY 6-4-8421
3	1710	2.024-39	3.000	5.250	EY 6-4-8421-1
3	1710	2.024-39	3.000	6.125	EY 6-4-8991-1X <i>High angle yoke</i>
3	1710	2.024-39	3.000	6.125	EY 6-4-8991X <i>High angle yoke</i>
3	1710	2.024-39	3.000	5.250	EY 6-4-9031-1X
3	1710	2.024-39	3.000	5.250	EY 6-4-9031X

410

1	1710	2.114-32	3.000	4.562	EY 6-4-5811
---	------	----------	-------	-------	-------------

433

3	1710	2.024-39	3.000	6.125	EY 6-4-8411-1 <i>High angle yoke</i>
---	------	----------	-------	-------	---

440

1	1610	2.422-18	3.375	6.125	EY 5-4-5491-1X
1	1710	2.422-18	3.375	5.250	EY 6-4-3161
1	1710	2.422-18	3.375	5.812	EY 6-4-4581
1	1710	2.422-18	3.375	5.812	EY 6-4-4581-1
1	1710	2.422-18	3.375	5.812	EY 6-4-4751-1X
1	1710	2.422-18	3.375	5.812	EY 6-4-4751X
1	1760	2.422-18	3.375	6.000	EY 6.3-4-241-1X
1	1760	2.422-18	3.375	6.000	EY 6.3-4-241X
1	1810	2.422-18	3.375	5.812	EY 6.5-4-1991
1	1810	2.422-18	3.375	5.812	EY 6.5-4-1991-1
1	1810	2.422-18	3.375	5.812	EY 6.5-4-2361-1X
1	1810	2.422-18	3.375	5.812	EY 6.5-4-2361X
2	1610	2.149-16	2.938	6.250	EY 5-4-5161-1X
2	1610	2.149-16	2.938	6.250	EY 5-4-5161X <i>High angle yoke</i>
2	1610	2.149-16	2.938	6.500	EY 5-4-5511X <i>High angle yoke</i>

Pos	Series	Spline Data	Hub Dia	* to End of Hub	End Fitting Part Number
-----	--------	-------------	---------	-----------------	-------------------------

440 (Continued)

2	1710	2.149-16	2.938	5.500	EY 6-4-4171-1X
2	1710	2.149-16	2.938	5.500	EY 6-4-4171X
2	1710	2.149-16	2.938	6.625	EY 6-4-4591 <i>High angle yoke</i>
2	1710	2.149-16	2.938	6.625	EY 6-4-5481X <i>High angle yoke</i>
2	1760	2.149-16	2.938	5.812	EY 6.3-4-141-1
2	1760	2.149-16	2.938	5.812	EY 6.3-4-251-1X
2	1760	2.149-16	2.938	5.812	EY 6.3-4-251X
2	1810	2.149-16	2.938	5.812	EY 6.5-4-2291
2	1810	2.149-16	2.938	5.812	EY 6.5-4-2291-1
2	1810	2.149-16	2.938	5.812	EY 6.5-4-2401-1X
2	1810	2.149-16	2.938	5.812	EY 6.5-4-2401X
3	1610	2.149-16	2.938	6.250	EY 5-4-5161-1X
3	1610	2.149-16	2.938	6.250	EY 5-4-5161X <i>High angle yoke</i>
3	1610	2.149-16	2.938	6.500	EY 5-4-5511X <i>High angle yoke</i>
3	1710	2.149-16	2.938	5.500	EY 6-4-4171-1X
3	1710	2.149-16	2.938	5.500	EY 6-4-4171X
3	1710	2.149-16	2.938	6.625	EY 6-4-5481X <i>High angle yoke</i>
3	1760	2.149-16	2.938	5.812	EY 6.3-4-141-1
3	1760	2.149-16	2.938	5.812	EY 6.3-4-251-1X
3	1760	2.149-16	2.938	5.812	EY 6.3-4-251X
3	1810	2.149-16	2.938	5.812	EY 6.5-4-2291
3	1810	2.149-16	2.938	5.812	EY 6.5-4-2291-1
3	1810	2.149-16	2.938	5.812	EY 6.5-4-2401-1X
3	1810	2.149-16	2.938	5.812	EY 6.5-4-2401X

451

1	1810	2.274-44	2.938	3.094	CF 6.5-1-2391
1	SPL170	2.274-44	2.938	5.281	EY 170-4-101-1X
1	SPL170	2.274-44	2.938	5.281	EY 170-4-91-1
1	SPL250	2.274-44	2.938	5.484	EY 250-4-51-1
1	SPL250	2.274-44	2.938	5.484	EY 250-4-61-1X
1	1610	2.274-44	2.938	5.000	EY 5-4-8321-1
1	1610	2.274-44	2.938	5.000	EY 5-4-8431-1X
1	1710	2.274-44	2.938	5.188	EY 6-4-8461
1	1710	2.274-44	2.938	5.188	EY 6-4-8461-1
1	1710	2.274-44	2.938	5.188	EY 6-4-8551-1X
1	1710	2.274-44	2.938	5.188	EY 6-4-8551X
1	1760	2.274-44	2.938	5.250	EY 6.3-4-1421
1	1760	2.274-44	2.938	5.250	EY 6.3-4-1421-1
1	1760	2.274-44	2.938	5.250	EY 6.3-4-1481-1X
1	1760	2.274-44	2.938	5.250	EY 6.3-4-1481X
1	1810	2.274-44	2.938	5.250	EY 6.5-4-4321
1	1810	2.274-44	2.938	5.250	EY 6.5-4-4321-1
1	1810	2.274-44	2.938	5.250	EY 6.5-4-4351-1X

*C/L to End of Hub for EY (End Yoke); Flange Face to End of Hub for CF (Companion Flange)

■ Hub machined for speedometer gear



Pos	Series	Spline Data	Hub Dia	* to End of Hub	End Fitting Part Number
451 (Continued)					
1	1810	2.274-44	2.938	5.250	EY 6.5-4-4351X
2	SPL170	1.790-34	2.625	5.600	EY 170-4-111-1
2	SPL170	1.790-34	2.625	5.600	EY 170-4-121-1X
2	SPL170	1.790-34	2.625	6.250	EY 170-4-131-1 <i>High angle yoke</i>
2	SPL170	1.790-34	2.625	6.250	EY 170-4-141-1X <i>High angle yoke</i>
2	1610	1.790-34	2.625	6.188	EY 5-4-8001 <i>High angle yoke</i>
2	1610	1.790-34	2.625	6.188	EY 5-4-8441X <i>High angle yoke</i>
2	1610	1.790-34	2.625	4.938	EY 5-4-8491-1
2	1610	1.790-34	2.625	4.938	EY 5-4-8501-1X
2	1710	1.790-34	2.625	6.312	EY 6-4-8001 <i>High angle yoke</i>
2	1710	1.790-34	2.625	6.312	EY 6-4-8001-1 <i>High angle yoke</i>
2	1710	1.790-34	2.625	5.438	EY 6-4-8081
2	1710	1.790-34	2.625	5.438	EY 6-4-8081-1
2	1710	1.790-34	2.625	6.312	EY 6-4-8521-1X <i>High angle yoke</i>
2	1710	1.790-34	2.625	6.312	EY 6-4-8521X <i>High angle yoke</i>
3	SPL140	2.024-39	2.625	5.030	EY 140-4-551-1 <i>Counterbore at hub end.</i>
3	SPL140	2.024-39	2.625	5.030	EY 140-4-561-1X <i>Counterbore at hub end.</i>
3	SPL170	2.024-39	2.625	4.938	EY 170-4-151-1
3	SPL170	2.024-39	2.625	4.938	EY 170-4-161-1X
3	SPL170	2.024-39	2.625	6.016	EY 170-4-171-1 <i>High angle yoke</i>
3	SPL170	2.024-39	2.625	6.016	EY 170-4-181-1X <i>High angle yoke</i>
3	1480	2.024-39	2.625	4.344	EY 3-4-13051-1
3	1480	2.024-39	2.625	4.344	EY 3-4-13061-1X
3	1550	2.024-39	2.625	4.266	EY 4-4-6471-1
3	1550	2.024-39	2.625	4.266	EY 4-4-7551-1X
3	1610	2.024-39	2.625	5.312	EY 5-4-7971
3	1610	2.024-39	2.625	5.312	EY 5-4-7971-1
3	1610	2.024-39	2.625	6.000	EY 5-4-7991 <i>High angle yoke</i>
3	1610	2.024-39	2.625	6.000	EY 5-4-8421X <i>High angle yoke</i>
3	1710	2.024-39	2.625	6.125	EY 6-4-7981 <i>High angle yoke</i>
3	1710	2.024-39	2.625	6.125	EY 6-4-7981-1 <i>High angle yoke</i>
3	1710	2.024-39	2.625	6.125	EY 6-4-8541-1X <i>High angle yoke</i>
3	1710	2.024-39	2.625	6.125	EY 6-4-8541X <i>High angle yoke</i>
454					
1	SPL140	2.274-44	3.000	5.160	EY 140-4-1261-1
1	SPL140	2.274-44	3.000	5.160	EY 140-4-1271-1X
1	SPL140	2.274-44	3.000	5.160	EY 140-4-321-1
1	SPL140	2.274-44	3.000	5.160	EY 140-4-331-1X
1	SPL170	2.274-44	3.000	5.270	EY 170-4-1671-1X <i>Counterbore at hub end.</i>
1	SPL170	2.274-44	3.000	5.270	EY 170-4-191-1
1	SPL170	2.274-44	3.000	5.270	EY 170-4-201-1X
1	SPL250	2.274-44	3.000	5.490	EY 250-4-71-1
1	SPL250	2.274-44	3.000	5.490	EY 250-4-81-1X

Pos	Series	Spline Data	Hub Dia	* to End of Hub	End Fitting Part Number
454 (Continued)					
1	1610	2.274-44	3.000	5.000	EY 5-4-8311-1
1	1610	2.274-44	3.000	5.000	EY 5-4-9261-1X
1	1710	2.274-44	3.000	5.190	EY 6-4-8451
1	1710	2.274-44	3.000	5.190	EY 6-4-8451-1
1	1710	2.274-44	3.000	5.190	EY 6-4-8981-1X
1	1710	2.274-44	3.000	5.190	EY 6-4-8981X
1	1760	2.274-44	3.000	5.250	EY 6.3-4-1411
1	1760	2.274-44	3.000	5.250	EY 6.3-4-1411-1
1	1760	2.274-44	3.000	5.250	EY 6.3-4-5221-1X
1	1760	2.274-44	3.000	5.250	EY 6.3-4-5221X
1	1810	2.274-44	3.000	5.250	EY 6.5-4-4311
1	1810	2.274-44	3.000	5.250	EY 6.5-4-4311-1
1	1810	2.274-44	3.000	5.250	EY 6.5-4-4571-1X
1	1810	2.274-44	3.000	5.250	EY 6.5-4-4571X
2	SPL140	2.024-39	3.000	4.940	EY 140-4-361-1
2	SPL170	2.024-39	2.625	6.500	EY 170-4-1651-1X
2	SPL170	2.024-39	2.625	5.270	EY 170-4-211-1 <i>High angle yoke</i>
2	SPL170	2.024-39	2.625	5.266	EY 170-4-221-1X
2	SPL170	2.024-39	2.625	6.500	EY 170-4-231-1 <i>High angle yoke</i>
2	SPL170	2.024-39	2.625	6.500	EY 170-4-241-1X <i>High angle yoke</i>
2	SPL170	2.024-39	2.625	5.750	EY 5001768
2	SPL170	2.024-39	2.625	5.750	EY 5008578
2	1610	2.024-39	2.625	6.000	EY 5-4-8301 <i>High angle yoke</i>
2	1610	2.024-39	2.625	6.000	EY 5-4-9271X <i>High angle yoke</i>
2	1710	2.024-39	2.625	6.125	EY 6-4-8431
2	1710	2.024-39	2.625	6.125	EY 6-4-8431-1
2	1710	2.024-39	2.625	5.250	EY 6-4-8441
2	1710	2.024-39	2.625	5.250	EY 6-4-8441-1
2	1710	2.024-39	2.625	6.125	EY 6-4-9001-1X
2	1710	2.024-39	2.625	6.125	EY 6-4-9001X
2	1710	2.024-39	2.625	5.250	EY 6-4-9041-1X
2	1710	2.024-39	2.625	5.250	EY 6-4-9041X
3	SPL140	2.024-39	3.000	4.940	EY 140-4-1151-1
3	SPL140	2.024-39	3.000	4.940	EY 140-4-1161-1X
3	SPL140	2.024-39	3.000	4.940	EY 140-4-361-1
3	SPL140	2.024-39	3.000	4.940	EY 140-4-371-1X
3	SPL170	2.024-39	3.000	5.540	EY 170-4-08577-1X
3	SPL170	2.024-39	3.000	6.240	EY 170-4-1621-1
3	SPL170	2.024-39	3.000	6.240	EY 170-4-1631-1X
3	SPL170	2.024-39	2.625	6.500	EY 170-4-1641-1
3	SPL170	2.274-44	3.000	5.270	EY 170-4-1661-1 <i>Counterbore at hub end.</i>
3	SPL170	2.274-44	3.000	5.270	EY 170-4-201-1X
3	SPL170	2.024-39	3.000	5.156	EY 170-4-251-1 <i>High angle yoke</i>
3	SPL170	2.024-39	3.000	5.156	EY 170-4-261-1X
3	SPL170	2.024-39	3.000	6.240	EY 170-4-271-1 <i>High angle yoke</i>
3	SPL170	2.024-39	3.000	6.240	EY 170-4-281-1X <i>High angle yoke</i>
3	SPL170	2.024-39	3.000	5.540	EY 5001766
3	SPL90	2.024-39	3.000	4.750	EY 90-4-241-1
3	SPL90	2.024-39	3.000	4.750	EY 90-4-251-1X
3	1480	2.024-39	3.000	4.344	EY 3-4-13071-1

Continued on next page

*C/L to End of Hub for EY (End Yoke); Flange Face to End of Hub for CF (Companion Flange)

■ Hub machined for speedometer gear



Important: See Safety Information in General Information Section (J300P-GI)

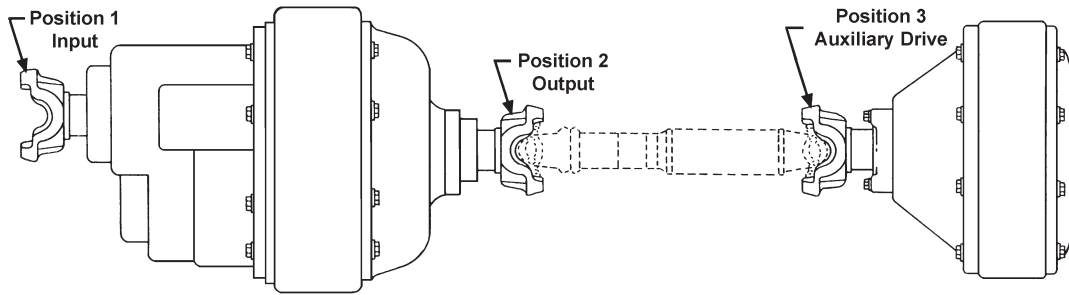

Pos	Series	Spline Data	Hub Dia	* to End of Hub	End Fitting Part Number
454 (Continued)					
3	1480	2.024-39	3.000	4.344	EY 3-4-13081-1X
3	1550	2.024-39	3.000	4.281	EY 4-4-7561-1
3	1550	2.024-39	3.000	4.281	EY 4-4-7571-1X
3	1610	2.024-39	3.000	6.000	EY 5-4-8261 <i>High angle yoke</i>
3	1610	2.024-39	3.000	6.000	EY 5-4-8261-1 <i>High angle yoke</i>
3	1610	2.024-39	3.000	4.875	EY 5-4-9221-1
3	1610	2.024-39	3.000	4.875	EY 5-4-9231-1X
3	1610	2.024-39	3.000	6.000	EY 5-4-9241-1X <i>High angle yoke</i>
3	1610	2.024-39	3.000	6.000	EY 5-4-9241X <i>High angle yoke</i>
3	1710	2.024-39	3.000	6.125	EY 6-4-8411-1 <i>High angle yoke</i>
3	1710	2.024-39	3.000	5.250	EY 6-4-8421
3	1710	2.024-39	3.000	5.250	EY 6-4-8421-1
3	1710	2.024-39	3.000	6.125	EY 6-4-8991-1X <i>High angle yoke</i>
3	1710	2.024-39	3.000	6.125	EY 6-4-8991X <i>High angle yoke</i>
3	1710	2.024-39	3.000	5.250	EY 6-4-9031-1X
3	1710	2.024-39	3.000	5.250	EY 6-4-9031X
5	SPL170	2.024-39	2.625	5.750	EY 170-4-08578-1X

Pos	Series	Spline Data	Hub Dia	* to End of Hub	End Fitting Part Number
460 (Continued)					
2	1760	2.149-16	2.938	5.812	EY 6.3-4-251-1X
2	1760	2.149-16	2.938	5.812	EY 6.3-4-251X
2	1810	2.422-18	3.375	5.812	EY 6.5-4-1991
2	1810	2.149-16	2.938	5.812	EY 6.5-4-2291-1
2	1810	2.149-16	2.938	5.812	EY 6.5-4-2401-1X
3	1610	2.149-16	2.938	6.250	EY 5-4-5161-1X
3	1610	2.149-16	2.938	6.250	EY 5-4-5161X <i>High angle yoke</i>
3	1610	2.149-16	2.938	6.500	EY 5-4-5511X <i>High angle yoke</i>
3	1710	2.149-16	2.938	5.500	EY 6-4-4171-1X
3	1710	2.149-16	2.938	5.500	EY 6-4-4171X
3	1710	2.149-16	2.938	6.625	EY 6-4-5481X <i>High angle yoke</i>
3	1760	2.149-16	2.938	5.812	EY 6.3-4-141-1
3	1760	2.149-16	2.938	5.812	EY 6.3-4-251-1X
3	1760	2.149-16	2.938	5.812	EY 6.3-4-251X
3	1810	2.422-18	3.375	5.812	EY 6.5-4-1991
3	1810	2.149-16	2.938	5.812	EY 6.5-4-2291-1
3	1810	2.149-16	2.938	5.812	EY 6.5-4-2401-1X
3	1810	2.149-16	2.938	5.812	EY 6.5-4-2401X

460					
1	1610	2.422-18	3.375	6.125	EY 5-4-5491-1X
1	1710	2.422-18	3.375	5.250	EY 6-4-3161
1	1710	2.422-18	3.375	5.812	EY 6-4-4581
1	1710	2.422-18	3.375	5.812	EY 6-4-4581-1
1	1710	2.422-18	3.375	5.812	EY 6-4-4751-1X
1	1710	2.422-18	3.375	5.812	EY 6-4-4751X
1	1760	2.422-18	3.375	6.000	EY 6.3-4-241-1X
1	1760	2.422-18	3.375	6.000	EY 6.3-4-241X
1	1810	2.422-18	3.375	5.812	EY 6.5-4-1991
1	1810	2.422-18	3.375	5.812	EY 6.5-4-1991-1
1	1810	2.422-18	3.375	5.812	EY 6.5-4-2361-1X
1	1810	2.422-18	3.375	5.812	EY 6.5-4-2361X
2	1610	2.149-16	2.938	6.250	EY 5-4-5161-1X
2	1610	2.149-16	2.938	6.250	EY 5-4-5161X <i>High angle yoke</i>
2	1610	2.149-16	2.938	6.500	EY 5-4-5511X <i>High angle yoke</i>
2	1710	2.149-16	2.938	5.500	EY 6-4-4171-1X
2	1710	2.149-16	2.938	5.500	EY 6-4-4171X
2	1710	2.149-16	2.938	6.625	EY 6-4-4591 <i>High angle yoke</i>
2	1710	2.149-16	2.938	6.625	EY 6-4-5481X <i>High angle yoke</i>
2	1760	2.149-16	2.938	5.812	EY 6.3-4-141-1

461					
1	SPL140	2.390-46	3.375	6.440	EY 140-4-381-1
1	SPL140	2.390-46	3.375	6.440	EY 140-4-391-1X
1	SPL170	2.390-46	3.375	6.531	EY 170-4-291-1
1	SPL170	2.390-46	3.375	6.531	EY 170-4-301-1X
1	SPL250	2.390-46	3.375	6.760	EY 250-4-101-1X
1	SPL250	2.390-46	3.375	6.760	EY 250-4-91-1
1	1550	2.143-41	2.938	4.500	EY 4-4-5581-1
1	1610	2.143-41	2.938	5.250	EY 5-4-7271-1
1	1610	2.143-41	2.938	6.000	EY 5-4-7561
1	1610	2.143-41	2.938	6.000	EY 5-4-7561-1
1	1610	2.143-41	2.938	5.250	EY 5-4-9111-1X
1	1610	2.143-41	2.938	6.000	EY 5-4-9121-1X
1	1610	2.143-41	2.938	6.000	EY 5-4-9121X
1	1710	2.390-46	3.375	6.000	EY 6-4-7511
1	1710	2.390-46	3.375	6.000	EY 6-4-7511-1
1	1710	2.390-46	3.375	6.000	EY 6-4-7531-1X
1	1710	2.390-46	3.375	6.000	EY 6-4-7531X
1	1710	2.390-46	3.375	6.000	EY 6-4-9201-1X
1	1760	2.143-41	2.938	5.250	EY 6.3-4-1061
1	1760	2.143-41	2.938	5.250	EY 6.3-4-1061-1
1	1760	2.390-46	3.375	6.000	EY 6.3-4-1151
1	1760	2.390-46	3.375	6.000	EY 6.3-4-1151-1
1	1760	2.390-46	3.375	6.000	EY 6.3-4-1161-1X
1	1760	2.390-46	3.375	6.000	EY 6.3-4-1161X
1	1760	2.143-41	2.938	5.250	EY 6.3-4-1631-1X

*C/L to End of Hub for EY (End Yoke); Flange Face to End of Hub for CF (Companion Flange)

■ Hub machined for speedometer gear



Pos	Series	Spline Data	Hub Dia	* to End of Hub	End Fitting Part Number
461 (Continued)					
1	1760	2.390-46	3.375	6.000	EY 6.3-4-1651-1X
1	1760	2.390-46	3.375	6.000	EY 6.3-4-1651X
1	1810	2.390-46	3.375	6.000	EY 6.5-4-3911
1	1810	2.390-46	3.375	6.000	EY 6.5-4-3911-1
1	1810	2.390-46	3.375	6.000	EY 6.5-4-3921-1X
1	1810	2.390-46	3.375	6.000	EY 6.5-4-3921X
1	1810	2.390-46	3.375	6.000	EY 6.5-4-4611-1X
1	1810	2.390-46	3.375	6.000	EY 6.5-4-4611X
2	SPL170	2.143-41	2.938	7.190	EY 170-4-311-1
2	SPL170	2.143-41	2.938	7.190	EY 170-4-321-1X <i>High angle yoke</i>
2	SPL170	2.143-41	2.938	5.800	EY 170-4-331-1
2	SPL170	2.143-41	2.938	5.800	EY 170-4-341-1X
2	1610	2.143-41	2.938	6.500	EY 5-4-7551-1
2	1610	2.143-41	2.938	6.500	EY 5-4-9131-1X
2	1710	2.149-16	2.938	6.625	EY 6-4-4591 <i>High angle yoke</i>
2	1710	2.143-41	2.938	6.625	EY 6-4-7541 <i>High angle yoke</i>
2	1710	2.143-41	2.938	6.625	EY 6-4-7541-1 <i>High angle yoke</i>
2	1710	2.143-41	2.938	6.625	EY 6-4-9191-1X <i>High angle yoke</i>
2	1710	2.143-41	2.938	6.625	EY 6-4-9191X <i>High angle yoke</i>
2	1760	2.143-41	2.938	5.812	EY 6.3-4-1171
2	1760	2.143-41	2.938	5.812	EY 6.3-4-1641X
2	1810	2.143-41	2.938	5.812	EY 6.5-4-3931
2	1810	2.143-41	2.938	5.812	EY 6.5-4-4621X
3	1810	2.143-41	2.938	3.500	CF 6.5-1-2941
3	SPL140	2.143-41	2.938	5.560	EY 140-4-421-1
3	SPL140	2.143-41	2.938	5.560	EY 140-4-431-1X
3	SPL170	2.143-41	2.938	5.320	EY 170-4-351-1
3	SPL170	2.143-41	2.938	5.320	EY 170-4-361-1X
3	SPL170	2.143-41	2.938	6.680	EY 170-4-371-1 <i>High angle yoke</i>
3	SPL170	2.143-41	2.938	6.680	EY 170-4-381-1X <i>High angle yoke</i>
3	SPL250	2.143-41	2.938	5.490	EY 250-4-131-1
3	SPL250	2.143-41	2.938	5.490	EY 250-4-141-1X
3	SPL90	2.143-41	2.938	4.562	EY 90-4-471-1
3	SPL90	2.143-41	2.938	4.562	EY 90-4-691-1X
3	1550	2.143-41	2.938	4.500	EY 4-4-5581-1
3	1550	2.143-41	2.938	4.500	EY 4-4-5701-1X
3	1610	2.143-41	2.938	6.000	EY 5-4-7571-1X
3	1610	2.143-41	2.938	6.000	EY 5-4-7571X
3	1610	2.143-41	2.938	5.250	EY 5-4-9111-1X
3	1610	2.143-41	2.938	6.000	EY 5-4-9121X
3	1710	2.143-41	2.938	5.190	EY 6-4-7311
3	1710	2.143-41	2.938	5.190	EY 6-4-7311-1
3	1710	2.143-41	2.938	5.190	EY 6-4-7321-1X
3	1710	2.143-41	2.938	6.125	EY 6-4-7551 <i>High angle yoke</i>
3	1710	2.143-41	2.938	6.125	EY 6-4-7551-1 <i>High angle yoke</i>
3	1710	2.143-41	2.938	6.125	EY 6-4-7561-1X <i>High angle yoke</i>
3	1710	2.143-41	2.938	6.125	EY 6-4-7561X <i>High angle yoke</i>
3	1710	2.143-41	2.938	5.190	EY 6-4-9171-1X
1	1760	2.390-46	3.375	6.000	EY 6.3-4-1651-1X

Pos	Series	Spline Data	Hub Dia	* to End of Hub	End Fitting Part Number
461 (Continued)					
3	1710	2.143-41	2.938	5.190	EY 6-4-9171X
3	1710	2.143-41	2.938	6.125	EY 6-4-9181-1X <i>High angle yoke</i>
3	1710	2.143-41	2.938	6.125	EY 6-4-9181X <i>High angle yoke</i>
3	1760	2.143-41	2.938	5.250	EY 6.3-4-1071-1X
3	1760	2.143-41	2.938	5.250	EY 6.3-4-1071X
3	1810	2.143-41	2.938	5.250	EY 6.5-4-3681
3	1810	2.143-41	2.938	5.250	EY 6.5-4-3681-1
3	1810	2.143-41	2.938	5.250	EY 6.5-4-3691-1X
3	1810	2.143-41	2.938	5.250	EY 6.5-4-3691X
3	1810	2.143-41	2.938	5.250	EY 6.5-4-4601-1X
3	1810	2.143-41	2.938	5.250	EY 6.5-4-4601X
462					
1	SPL140	2.390-46	3.375	6.440	EY 140-4-381-1
1	SPL140	2.390-46	3.375	6.440	EY 140-4-391-1X
1	SPL140	2.143-41	2.938	5.560	EY 140-4-421-1
1	SPL170	2.390-46	3.375	6.531	EY 170-4-301-1X
1	SPL250	2.390-46	3.375	6.760	EY 250-4-101-1X
1	1550	2.143-41	2.938	4.500	EY 4-4-5581-1
1	1610	2.143-41	2.938	5.250	EY 5-4-7271-1
1	1610	2.143-41	2.938	6.000	EY 5-4-7561
1	1610	2.143-41	2.938	6.000	EY 5-4-7561-1
1	1610	2.143-41	2.938	5.250	EY 5-4-9111-1X
1	1610	2.143-41	2.938	6.000	EY 5-4-9121-1X
1	1610	2.143-41	2.938	6.000	EY 5-4-9121X
1	1710	2.390-46	3.375	6.000	EY 6-4-7511
1	1710	2.390-46	3.375	6.000	EY 6-4-7511-1
1	1710	2.390-46	3.375	6.000	EY 6-4-9201-1X
1	1760	2.143-41	2.938	5.250	EY 6.3-4-1061
1	1760	2.143-41	2.938	5.250	EY 6.3-4-1061-1
1	1760	2.390-46	3.375	6.000	EY 6.3-4-1151
1	1760	2.390-46	3.375	6.000	EY 6.3-4-1151-1
1	1760	2.143-41	2.938	5.250	EY 6.3-4-1631-1X
1	1760	2.390-46	3.375	6.000	EY 6.3-4-1651-1X
1	1810	2.390-46	3.375	6.000	EY 6.5-4-3911
1	1810	2.390-46	3.375	6.000	EY 6.5-4-3911-1
1	1810	2.390-46	3.375	6.000	EY 6.5-4-4611-1X
1	1810	2.390-46	3.375	6.000	EY 6.5-4-4611X
2	1610	2.143-41	2.938	6.500	EY 5-4-7551-1
2	1610	2.143-41	2.938	6.500	EY 5-4-9131-1X
2	1710	2.143-41	2.938	6.625	EY 6-4-7541-1 <i>High angle yoke</i>
2	1710	2.143-41	2.938	6.625	EY 6-4-9191-1X <i>High angle yoke</i>
2	1710	2.143-41	2.938	6.625	EY 6-4-9191X <i>High angle yoke</i>
2	1760	2.143-41	2.938	5.812	EY 6.3-4-1641X
2	1810	2.143-41	2.938	5.812	EY 6.5-4-4621X
3	1810	2.143-41	2.938	3.500	CF 6.5-1-2941
3	SPL140	2.143-41	2.938	5.560	EY 140-4-431-1X
3	SPL170	2.143-41	2.938	5.320	EY 170-4-361-1X
3	SPL170	2.143-41	2.938	6.680	EY 170-4-381-1X <i>High angle yoke</i>
3	SPL90	2.143-41	2.938	4.562	EY 90-4-471-1
3	SPL90	2.143-41	2.938	4.562	EY 90-4-691-1X
3	1550	2.143-41	2.938	4.500	EY 4-4-5581-1

Continued on next page

*C/L to End of Hub for EY (End Yoke); Flange Face to End of Hub for CF (Companion Flange)

■ Hub machined for speedometer gear



Important: See Safety Information in General Information Section (J300P-GI)

TANDEM AXLES

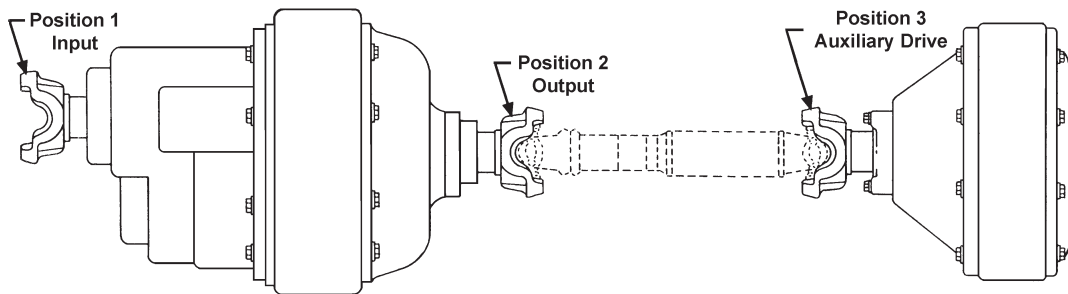

Pos	Series	Spline Data	Hub Dia	* to End of Hub	End Fitting Part Number
-----	--------	-------------	---------	-----------------	-------------------------

462 (Continued)

3	1610	2.143-41	2.938	6.000	EY 5-4-7571-1X
3	1610	2.143-41	2.938	5.250	EY 5-4-9111-1X
3	1610	2.143-41	2.938	6.000	EY 5-4-9121X
3	1710	2.143-41	2.938	5.190	EY 6-4-7311
3	1710	2.143-41	2.938	5.190	EY 6-4-7311-1
3	1710	2.143-41	2.938	6.125	EY 6-4-7551 <i>High angle yoke</i>
3	1710	2.143-41	2.938	6.125	EY 6-4-7551-1 <i>High angle yoke</i>
3	1710	2.143-41	2.938	5.190	EY 6-4-9171-1X
3	1710	2.143-41	2.938	5.190	EY 6-4-9171X
3	1710	2.143-41	2.938	6.125	EY 6-4-9181-1X <i>High angle yoke</i>
3	1710	2.143-41	2.938	6.125	EY 6-4-9181X <i>High angle yoke</i>
3	1810	2.143-41	2.938	5.250	EY 6.5-4-3681
3	1810	2.143-41	2.938	5.250	EY 6.5-4-3681-1
3	1810	2.143-41	2.938	5.250	EY 6.5-4-3691-1X
3	1810	2.143-41	2.938	5.250	EY 6.5-4-4601-1X
3	1810	2.143-41	2.938	5.250	EY 6.5-4-4601X

463

1	SPL170	2.390-46	3.375	6.531	EY 170-4-301-1X
1	SPL250	2.390-46	3.375	6.760	EY 250-4-101-1X
1	1710	2.390-46	3.375	6.000	EY 6-4-9201-1X
1	1760	2.390-46	3.375	6.000	EY 6.3-4-1651-1X
1	1760	2.390-46	3.375	6.000	EY 6.3-4-1651X
1	1810	2.390-46	3.375	6.000	EY 6.5-4-4611-1X
1	1810	2.390-46	3.375	6.000	EY 6.5-4-4611X
2	1710	2.143-41	2.938	6.625	EY 6-4-9191-1X <i>High angle yoke</i>
2	1710	2.143-41	2.938	6.625	EY 6-4-9191X <i>High angle yoke</i>
2	1810	2.143-41	2.938	5.812	EY 6.5-4-4621X
3	SPL170	2.143-41	2.938	5.320	EY 170-4-361-1X
3	SPL170	2.143-41	2.938	6.680	EY 170-4-381-1X <i>High angle yoke</i>
3	1610	2.143-41	2.938	5.250	EY 5-4-9111-1X
3	1610	2.143-41	2.938	6.000	EY 5-4-9121X
3	1710	2.143-41	2.938	6.125	EY 6-4-9181-1X <i>High angle yoke</i>
3	1710	2.143-41	2.938	6.125	EY 6-4-9181X <i>High angle yoke</i>
3	1810	2.143-41	2.938	5.250	EY 6.5-4-4601X

466

1	1710	2.390-46	3.375	6.000	EY 6-4-7531-1X
1	1710	2.390-46	3.375	6.000	EY 6-4-7531X
1	1760	2.390-46	3.375	6.000	EY 6.3-4-1161-1X
1	1760	2.390-46	3.375	6.000	EY 6.3-4-1161X
1	1810	2.390-46	3.375	6.000	EY 6.5-4-3921-1X

Pos	Series	Spline Data	Hub Dia	* to End of Hub	End Fitting Part Number
-----	--------	-------------	---------	-----------------	-------------------------

466 (Continued)

1	1810	2.390-46	3.375	6.000	EY 6.5-4-3921X
2	1710	2.143-41	2.938	6.625	EY 6-4-7541 <i>High angle yoke</i>
2	1710	2.143-41	2.938	6.625	EY 6-4-7651-1X <i>High angle yoke</i>
2	1710	2.143-41	2.938	6.625	EY 6-4-7651X <i>High angle yoke</i>
2	1760	2.143-41	2.938	5.812	EY 6.3-4-1171
2	1810	2.143-41	2.938	5.812	EY 6.5-4-3931
3	1550	2.143-41	2.938	4.500	EY 4-4-5701-1X
3	1610	2.143-41	2.938	5.250	EY 5-4-7311-1X
3	1610	2.143-41	2.938	6.000	EY 5-4-7571X
3	1710	2.143-41	2.938	5.190	EY 6-4-7321-1X
3	1710	2.143-41	2.938	6.125	EY 6-4-7561X <i>High angle yoke</i>
3	1760	2.143-41	2.938	5.250	EY 6.3-4-1071-1X
3	1760	2.143-41	2.938	5.250	EY 6.3-4-1071X
3	1810	2.143-41	2.938	5.250	EY 6.5-4-3691X

480

1	1610	2.422-18	3.375	6.125	EY 5-4-5491-1X
1	1710	2.422-18	3.375	5.250	EY 6-4-3161
1	1710	2.422-18	3.375	5.812	EY 6-4-4581
1	1710	2.422-18	3.375	5.812	EY 6-4-4581-1
1	1710	2.422-18	3.375	5.812	EY 6-4-4751-1X
1	1710	2.422-18	3.375	5.812	EY 6-4-4751X
1	1760	2.422-18	3.375	6.000	EY 6.3-4-241-1X
1	1760	2.422-18	3.375	6.000	EY 6.3-4-241X
1	1810	2.422-18	3.375	5.812	EY 6.5-4-1991
1	1810	2.422-18	3.375	5.812	EY 6.5-4-1991-1
1	1810	2.422-18	3.375	5.812	EY 6.5-4-2361-1X
1	1810	2.422-18	3.375	5.812	EY 6.5-4-2361X
2	1610	2.149-16	2.938	6.250	EY 5-4-5161-1X
2	1610	2.149-16	2.938	6.250	EY 5-4-5161X <i>High angle yoke</i>
2	1610	2.149-16	2.938	6.500	EY 5-4-5511X <i>High angle yoke</i>
2	1710	2.149-16	2.938	5.500	EY 6-4-4171-1X
2	1710	2.149-16	2.938	5.500	EY 6-4-4171X
2	1710	2.149-16	2.938	6.625	EY 6-4-4591 <i>High angle yoke</i>
2	1710	2.149-16	2.938	6.625	EY 6-4-5481X <i>High angle yoke</i>
2	1760	2.149-16	2.938	5.812	EY 6.3-4-141-1
2	1760	2.149-16	2.938	5.812	EY 6.3-4-251-1X
2	1760	2.149-16	2.938	5.812	EY 6.3-4-251X
2	1810	2.422-18	3.375	5.812	EY 6.5-4-1991
2	1810	2.149-16	2.938	5.812	EY 6.5-4-2291-1
2	1810	2.149-16	2.938	5.812	EY 6.5-4-2401-1X
2	1810	2.149-16	2.938	5.812	EY 6.5-4-2401X

*C/L to End of Hub for EY (End Yoke); Flange Face to End of Hub for CF (Companion Flange)

■ Hub machined for speedometer gear



Pos	Series	Spline Data	Hub Dia	* to End of Hub	End Fitting Part Number
480 (Continued)					
3	1610	2.149-16	2.938	6.250	EY 5-4-5161-1X
3	1610	2.149-16	2.938	6.250	EY 5-4-5161X <i>High angle yoke</i>
3	1610	2.149-16	2.938	6.500	EY 5-4-5511X <i>High angle yoke</i>
3	1710	2.149-16	2.938	5.500	EY 6-4-4171-1X
3	1710	2.149-16	2.938	5.500	EY 6-4-4171X
3	1710	2.149-16	2.938	6.625	EY 6-4-5481X <i>High angle yoke</i>
3	1760	2.149-16	2.938	5.812	EY 6.3-4-141-1
3	1760	2.149-16	2.938	5.812	EY 6.3-4-251-1X
3	1760	2.149-16	2.938	5.812	EY 6.3-4-251X
3	1810	2.422-18	3.375	5.812	EY 6.5-4-1991
3	1810	2.149-16	2.938	5.812	EY 6.5-4-2291-1
3	1810	2.149-16	2.938	5.812	EY 6.5-4-2401-1X
3	1810	2.149-16	2.938	5.812	EY 6.5-4-2401X

481					
1	SPL140	2.390-46	3.375	6.440	EY 140-4-381-1
1	SPL140	2.390-46	3.375	6.440	EY 140-4-391-1X
1	SPL140	2.143-41	2.938	5.560	EY 140-4-421-1
1	SPL170	2.390-46	3.375	6.531	EY 170-4-291-1
1	SPL170	2.390-46	3.375	6.531	EY 170-4-301-1X
1	SPL250	2.390-46	3.375	6.760	EY 250-4-101-1X
1	SPL250	2.390-46	3.375	6.760	EY 250-4-91-1
1	1550	2.143-41	2.938	4.500	EY 4-4-5581-1
1	1610	2.143-41	2.938	5.250	EY 5-4-7271-1
1	1610	2.143-41	2.938	6.000	EY 5-4-7561
1	1610	2.143-41	2.938	6.000	EY 5-4-7561-1
1	1610	2.143-41	2.938	5.250	EY 5-4-9111-1X
1	1610	2.143-41	2.938	6.000	EY 5-4-9121-1X
1	1610	2.143-41	2.938	6.000	EY 5-4-9121X
1	1710	2.390-46	3.375	6.000	EY 6-4-7511
1	1710	2.390-46	3.375	6.000	EY 6-4-7511-1
1	1710	2.390-46	3.375	6.000	EY 6-4-9201-1X
1	1760	2.143-41	2.938	5.250	EY 6.3-4-1061
1	1760	2.143-41	2.938	5.250	EY 6.3-4-1061-1
1	1760	2.390-46	3.375	6.000	EY 6.3-4-1151
1	1760	2.390-46	3.375	6.000	EY 6.3-4-1151-1
1	1760	2.390-46	3.375	6.000	EY 6.3-4-1161-1X
1	1760	2.390-46	3.375	6.000	EY 6.3-4-1161X
1	1760	2.143-41	2.938	5.250	EY 6.3-4-1631-1X
1	1760	2.390-46	3.375	6.000	EY 6.3-4-1651-1X
1	1760	2.390-46	3.375	6.000	EY 6.3-4-1651X
1	1810	2.390-46	3.375	6.000	EY 6.5-4-3911
1	1810	2.390-46	3.375	6.000	EY 6.5-4-3911-1
1	1810	2.390-46	3.375	6.000	EY 6.5-4-3921-1X
1	1810	2.390-46	3.375	6.000	EY 6.5-4-3921X
1	1810	2.390-46	3.375	6.000	EY 6.5-4-4611-1X
1	1810	2.390-46	3.375	6.000	EY 6.5-4-4611X
2	SPL170	2.143-41	2.938	7.190	EY 170-4-311-1
2	SPL170	2.143-41	2.938	7.190	EY 170-4-321-1X <i>High angle yoke</i>
2	SPL170	2.143-41	2.938	5.800	EY 170-4-331-1
2	SPL170	2.143-41	2.938	5.800	EY 170-4-341-1X
2	1610	2.143-41	2.938	6.500	EY 5-4-7551-1
2	1610	2.143-41	2.938	6.500	EY 5-4-9131-1X
2	1710	2.143-41	2.938	6.625	EY 6-4-7541 <i>High angle yoke</i>
2	1710	2.143-41	2.938	6.625	EY 6-4-7541-1 <i>High angle yoke</i>

Pos	Series	Spline Data	Hub Dia	* to End of Hub	End Fitting Part Number
481 (Continued)					
2	1710	2.143-41	2.938	6.625	EY 6-4-9191-1X <i>High angle yoke</i>
2	1710	2.143-41	2.938	6.625	EY 6-4-9191X <i>High angle yoke</i>
2	1760	2.143-41	2.938	5.812	EY 6.3-4-1171
2	1760	2.143-41	2.938	5.812	EY 6.3-4-1641X
2	1810	2.143-41	2.938	5.812	EY 6.5-4-3931
2	1810	2.143-41	2.938	5.812	EY 6.5-4-4621X
3	1810	2.143-41	2.938	3.500	CF 6.5-1-2941
3	SPL140	2.143-41	2.938	5.560	EY 140-4-431-1X
3	SPL170	2.143-41	2.938	5.320	EY 170-4-351-1
3	SPL170	2.143-41	2.938	5.320	EY 170-4-361-1X
3	SPL170	2.143-41	2.938	6.680	EY 170-4-371-1 <i>High angle yoke</i>
3	SPL170	2.143-41	2.938	6.680	EY 170-4-381-1X <i>High angle yoke</i>
3	SPL250	2.143-41	2.938	5.490	EY 250-4-131-1
3	SPL250	2.143-41	2.938	5.490	EY 250-4-141-1X
3	SPL90	2.143-41	2.938	4.562	EY 90-4-471-1
3	SPL90	2.143-41	2.938	4.562	EY 90-4-691-1X
3	1550	2.143-41	2.938	4.500	EY 4-4-5581-1
3	1610	2.143-41	2.938	6.000	EY 5-4-7571-1X
3	1610	2.143-41	2.938	6.000	EY 5-4-7571X
3	1710	2.143-41	2.938	5.190	EY 6-4-7311
3	1710	2.143-41	2.938	5.190	EY 6-4-7311-1
3	1710	2.143-41	2.938	5.190	EY 6-4-7321-1X
3	1710	2.143-41	2.938	6.125	EY 6-4-7551 <i>High angle yoke</i>
3	1710	2.143-41	2.938	6.125	EY 6-4-7551-1 <i>High angle yoke</i>
3	1710	2.143-41	2.938	6.125	EY 6-4-7561-1X <i>High angle yoke</i>
3	1710	2.143-41	2.938	6.125	EY 6-4-7561X <i>High angle yoke</i>
3	1710	2.143-41	2.938	5.190	EY 6-4-9171-1X
3	1710	2.143-41	2.938	5.190	EY 6-4-9171X
3	1710	2.143-41	2.938	6.125	EY 6-4-9181-1X <i>High angle yoke</i>
3	1710	2.143-41	2.938	6.125	EY 6-4-9181X <i>High angle yoke</i>
3	1760	2.143-41	2.938	5.250	EY 6.3-4-1071-1X
3	1760	2.143-41	2.938	5.250	EY 6.3-4-1071X
3	1810	2.143-41	2.938	5.250	EY 6.5-4-3681
3	1810	2.143-41	2.938	5.250	EY 6.5-4-3681-1
3	1810	2.143-41	2.938	5.250	EY 6.5-4-3691-1X
3	1810	2.143-41	2.938	5.250	EY 6.5-4-3691X
3	1810	2.143-41	2.938	5.250	EY 6.5-4-4601-1X
3	1810	2.143-41	2.938	5.250	EY 6.5-4-4601X

521					
1	SPL140	2.390-46	3.375	6.440	EY 140-4-381-1
1	SPL140	2.390-46	3.375	6.440	EY 140-4-391-1X
1	SPL170	2.390-46	3.375	6.531	EY 170-4-291-1
1	SPL170	2.390-46	3.375	6.531	EY 170-4-301-1X
1	SPL250	2.390-46	3.375	6.760	EY 250-4-101-1X
1	SPL250	2.390-46	3.375	6.760	EY 250-4-91-1
1	1550	2.143-41	2.938	4.500	EY 4-4-5581-1
1	1610	2.143-41	2.938	5.250	EY 5-4-7271-1
1	1610	2.143-41	2.938	6.000	EY 5-4-7561
1	1610	2.143-41	2.938	6.000	EY 5-4-7561-1

Continued on next page

*C/L to End of Hub for EY (End Yoke); Flange Face to End of Hub for CF (Companion Flange)

■ Hub machined for speedometer gear



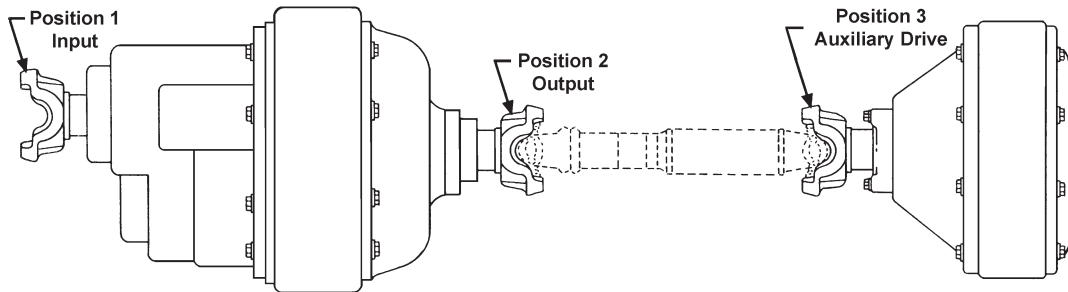

Pos	Series	Spline Data	Hub Dia	* to End of Hub	End Fitting Part Number
-----	--------	-------------	---------	-----------------	-------------------------

521 (Continued)

1	1610	2.143-41	2.938	5.250	EY 5-4-9111-1X
1	1610	2.143-41	2.938	6.000	EY 5-4-9121-1X
1	1610	2.143-41	2.938	6.000	EY 5-4-9121X
1	1710	2.390-46	3.375	6.000	EY 6-4-7511
1	1710	2.390-46	3.375	6.000	EY 6-4-7511-1
1	1710	2.390-46	3.375	6.000	EY 6-4-7531-1X
1	1710	2.390-46	3.375	6.000	EY 6-4-7531X
1	1710	2.390-46	3.375	6.000	EY 6-4-9201-1X
1	1760	2.143-41	2.938	5.250	EY 6.3-4-1061
1	1760	2.143-41	2.938	5.250	EY 6.3-4-1061-1
1	1760	2.390-46	3.375	6.000	EY 6.3-4-1151
1	1760	2.390-46	3.375	6.000	EY 6.3-4-1151-1
1	1760	2.390-46	3.375	6.000	EY 6.3-4-1161-1X
1	1760	2.390-46	3.375	6.000	EY 6.3-4-1161X
1	1760	2.143-41	2.938	5.250	EY 6.3-4-1631-1X
1	1760	2.390-46	3.375	6.000	EY 6.3-4-1651-1X
1	1760	2.390-46	3.375	6.000	EY 6.3-4-1651X
1	1810	2.390-46	3.375	6.000	EY 6.5-4-3911
1	1810	2.390-46	3.375	6.000	EY 6.5-4-3911-1
1	1810	2.390-46	3.375	6.000	EY 6.5-4-3921-1X
1	1810	2.390-46	3.375	6.000	EY 6.5-4-3921X
1	1810	2.390-46	3.375	6.000	EY 6.5-4-4611-1X
1	1810	2.390-46	3.375	6.000	EY 6.5-4-4611X
2	SPL170	2.143-41	2.938	7.190	EY 170-4-311-1
2	SPL170	2.143-41	2.938	7.190	EY 170-4-321-1X <i>High angle yoke</i>
2	SPL170	2.143-41	2.938	5.800	EY 170-4-331-1
2	SPL170	2.143-41	2.938	5.800	EY 170-4-341-1X
2	1610	2.143-41	2.938	6.500	EY 5-4-7551-1
2	1610	2.143-41	2.938	6.500	EY 5-4-9131-1X
2	1710	2.143-41	2.938	6.625	EY 6-4-7541 <i>High angle yoke</i>
2	1710	2.143-41	2.938	6.625	EY 6-4-7541-1 <i>High angle yoke</i>
2	1710	2.143-41	2.938	6.625	EY 6-4-9191-1X <i>High angle yoke</i>
2	1710	2.143-41	2.938	6.625	EY 6-4-9191X <i>High angle yoke</i>
2	1760	2.143-41	2.938	5.812	EY 6.3-4-1171
2	1760	2.143-41	2.938	5.812	EY 6.3-4-1641X
2	1810	2.143-41	2.938	5.812	EY 6.5-4-3931
2	1810	2.143-41	2.938	5.812	EY 6.5-4-4621X
3	1810	2.143-41	2.938	3.500	CF 6.5-1-2941
3	SPL140	2.143-41	2.938	5.560	EY 140-4-421-1
3	SPL140	2.143-41	2.938	5.560	EY 140-4-431-1X
3	SPL170	2.143-41	2.938	5.320	EY 170-4-351-1
3	SPL170	2.143-41	2.938	5.320	EY 170-4-361-1X
3	SPL170	2.143-41	2.938	6.680	EY 170-4-371-1 <i>High angle yoke</i>

Pos	Series	Spline Data	Hub Dia	* to End of Hub	End Fitting Part Number
-----	--------	-------------	---------	-----------------	-------------------------

521 (Continued)

3	SPL170	2.143-41	2.938	6.680	EY 170-4-381-1X <i>High angle yoke</i>
3	SPL250	2.143-41	2.938	5.490	EY 250-4-131-1
3	SPL250	2.143-41	2.938	5.490	EY 250-4-141-1X
3	SPL90	2.143-41	2.938	4.562	EY 90-4-471-1
3	SPL90	2.143-41	2.938	4.562	EY 90-4-691-1X
3	1550	2.143-41	2.938	4.500	EY 4-4-5581-1
3	1550	2.143-41	2.938	4.500	EY 4-4-5701-1X
3	1610	2.143-41	2.938	5.250	EY 5-4-7311-1X
3	1610	2.143-41	2.938	6.000	EY 5-4-7571-1X
3	1610	2.143-41	2.938	6.000	EY 5-4-7571X
3	1610	2.143-41	2.938	5.250	EY 5-4-9111-1X
3	1610	2.143-41	2.938	6.000	EY 5-4-9121X
3	1710	2.143-41	2.938	5.190	EY 6-4-7311
3	1710	2.143-41	2.938	5.190	EY 6-4-7311-1
3	1710	2.143-41	2.938	5.190	EY 6-4-7321-1X
3	1710	2.143-41	2.938	6.125	EY 6-4-7551 <i>High angle yoke</i>
3	1710	2.143-41	2.938	6.125	EY 6-4-7551-1 <i>High angle yoke</i>
3	1710	2.143-41	2.938	6.125	EY 6-4-7561-1X <i>High angle yoke</i>
3	1710	2.143-41	2.938	6.125	EY 6-4-7561X <i>High angle yoke</i>
3	1710	2.143-41	2.938	5.190	EY 6-4-9171-1X
3	1710	2.143-41	2.938	5.190	EY 6-4-9171X
3	1710	2.143-41	2.938	6.125	EY 6-4-9181-1X <i>High angle yoke</i>
3	1710	2.143-41	2.938	6.125	EY 6-4-9181X <i>High angle yoke</i>
3	1760	2.143-41	2.938	5.250	EY 6.3-4-1071-1X
3	1760	2.143-41	2.938	5.250	EY 6.3-4-1071X
3	1810	2.143-41	2.938	5.250	EY 6.5-4-3681
3	1810	2.143-41	2.938	5.250	EY 6.5-4-3681-1
3	1810	2.143-41	2.938	5.250	EY 6.5-4-3691-1X
3	1810	2.143-41	2.938	5.250	EY 6.5-4-3691X
3	1810	2.143-41	2.938	5.250	EY 6.5-4-4601-1X
3	1810	2.143-41	2.938	5.250	EY 6.5-4-4601X
580					
1	1710	2.422-18	3.375	5.812	EY 6-4-4581
1	1710	2.422-18	3.375	5.812	EY 6-4-4581-1
1	1810	2.422-18	3.375	5.812	EY 6.5-4-1991
1	1810	2.422-18	3.375	5.812	EY 6.5-4-1991-1
581, 601					
1	SPL140	2.390-46	3.375	6.440	EY 140-4-381-1
1	SPL140	2.390-46	3.375	6.440	EY 140-4-391-1X
1	SPL170	2.390-46	3.375	6.531	EY 170-4-291-1
1	SPL170	2.390-46	3.375	6.531	EY 170-4-301-1X

*C/L to End of Hub for EY (End Yoke); Flange Face to End of Hub for CF (Companion Flange)

■ Hub machined for speedometer gear



Pos	Series	Spline Data	Hub Dia	* to End of Hub	End Fitting Part Number
581, 601 (Continued)					
1	SPL250	2.390-46	3.375	6.760	EY 250-4-101-1X
1	SPL250	2.390-46	3.375	6.760	EY 250-4-91-1
1	1550	2.143-41	2.938	4.500	EY 4-4-5581-1
1	1610	2.143-41	2.938	5.250	EY 5-4-7271-1
1	1610	2.143-41	2.938	6.000	EY 5-4-7561
1	1610	2.143-41	2.938	6.000	EY 5-4-7561-1
1	1610	2.143-41	2.938	5.250	EY 5-4-9111-1X
1	1610	2.143-41	2.938	6.000	EY 5-4-9121-1X
1	1610	2.143-41	2.938	6.000	EY 5-4-9121X
1	1710	2.390-46	3.375	6.000	EY 6-4-7511
1	1710	2.390-46	3.375	6.000	EY 6-4-7511-1
1	1710	2.390-46	3.375	6.000	EY 6-4-7531-1X
1	1710	2.390-46	3.375	6.000	EY 6-4-7531X
1	1710	2.390-46	3.375	6.000	EY 6-4-9201-1X
1	1760	2.143-41	2.938	5.250	EY 6.3-4-1061
1	1760	2.143-41	2.938	5.250	EY 6.3-4-1061-1
1	1760	2.390-46	3.375	6.000	EY 6.3-4-1151
1	1760	2.390-46	3.375	6.000	EY 6.3-4-1151-1
1	1760	2.390-46	3.375	6.000	EY 6.3-4-1161-1X
1	1760	2.390-46	3.375	6.000	EY 6.3-4-1161X
1	1760	2.143-41	2.938	5.250	EY 6.3-4-1631-1X
1	1760	2.390-46	3.375	6.000	EY 6.3-4-1651-1X
1	1760	2.390-46	3.375	6.000	EY 6.3-4-1651X
1	1810	2.390-46	3.375	6.000	EY 6.5-4-3911
1	1810	2.390-46	3.375	6.000	EY 6.5-4-3911-1
1	1810	2.390-46	3.375	6.000	EY 6.5-4-3921-1X
1	1810	2.390-46	3.375	6.000	EY 6.5-4-3921X
1	1810	2.390-46	3.375	6.000	EY 6.5-4-4611-1X
1	1810	2.390-46	3.375	6.000	EY 6.5-4-4611X
2	SPL170	2.143-41	2.938	7.190	EY 170-4-311-1
2	SPL170	2.143-41	2.938	7.190	EY 170-4-321-1X <i>High angle yoke</i>
2	SPL170	2.143-41	2.938	5.800	EY 170-4-331-1
2	SPL170	2.143-41	2.938	5.800	EY 170-4-341-1X
2	1610	2.143-41	2.938	6.500	EY 5-4-7551-1
2	1610	2.143-41	2.938	6.500	EY 5-4-9131-1X
2	1710	2.143-41	2.938	6.625	EY 6-4-7541 <i>High angle yoke</i>
2	1710	2.143-41	2.938	6.625	EY 6-4-7541-1 <i>High angle yoke</i>
2	1710	2.143-41	2.938	6.625	EY 6-4-9191-1X <i>High angle yoke</i>
2	1710	2.143-41	2.938	6.625	EY 6-4-9191X <i>High angle yoke</i>
2	1760	2.143-41	2.938	5.812	EY 6.3-4-1171
2	1760	2.143-41	2.938	5.812	EY 6.3-4-1641X
2	1810	2.143-41	2.938	5.812	EY 6.5-4-3931
2	1810	2.143-41	2.938	5.812	EY 6.5-4-4621X
3	1810	2.143-41	2.938	3.500	CF 6.5-1-2941
3	SPL140	2.143-41	2.938	5.560	EY 140-4-421-1
3	SPL140	2.143-41	2.938	5.560	EY 140-4-431-1X
3	SPL170	2.143-41	2.938	5.320	EY 170-4-351-1
3	SPL170	2.143-41	2.938	5.320	EY 170-4-361-1X
3	SPL170	2.143-41	2.938	6.680	EY 170-4-371-1 <i>High angle yoke</i>
3	SPL170	2.143-41	2.938	6.680	EY 170-4-381-1X <i>High angle yoke</i>
3	SPL250	2.143-41	2.938	5.490	EY 250-4-131-1
3	SPL250	2.143-41	2.938	5.490	EY 250-4-141-1X

Pos	Series	Spline Data	Hub Dia	* to End of Hub	End Fitting Part Number
581, 601 (Continued)					
3	SPL90	2.143-41	2.938	4.562	EY 90-4-471-1
3	SPL90	2.143-41	2.938	4.562	EY 90-4-691-1X
3	1550	2.143-41	2.938	4.500	EY 4-4-5581-1
3	1610	2.143-41	2.938	5.250	EY 5-4-7311-1X
3	1610	2.143-41	2.938	6.000	EY 5-4-7571-1X
3	1610	2.143-41	2.938	6.000	EY 5-4-7571X
3	1610	2.143-41	2.938	5.250	EY 5-4-9111-1X
3	1610	2.143-41	2.938	6.000	EY 5-4-9121X
3	1710	2.143-41	2.938	5.190	EY 6-4-7311
3	1710	2.143-41	2.938	5.190	EY 6-4-7311-1
3	1710	2.143-41	2.938	5.190	EY 6-4-7321-1X
3	1710	2.143-41	2.938	6.125	EY 6-4-7551 <i>High angle yoke</i>
3	1710	2.143-41	2.938	6.125	EY 6-4-7551-1 <i>High angle yoke</i>
3	1710	2.143-41	2.938	6.125	EY 6-4-7561-1X <i>High angle yoke</i>
3	1710	2.143-41	2.938	6.125	EY 6-4-7561X <i>High angle yoke</i>
3	1710	2.143-41	2.938	5.190	EY 6-4-9171-1X
3	1710	2.143-41	2.938	5.190	EY 6-4-9171X
3	1710	2.143-41	2.938	6.125	EY 6-4-9181-1X <i>High angle yoke</i>
3	1710	2.143-41	2.938	6.125	EY 6-4-9181X <i>High angle yoke</i>
3	1760	2.143-41	2.938	5.250	EY 6.3-4-1071-1X
3	1760	2.143-41	2.938	5.250	EY 6.3-4-1071X
3	1810	2.143-41	2.938	5.250	EY 6.5-4-3681
3	1810	2.143-41	2.938	5.250	EY 6.5-4-3681-1
3	1810	2.143-41	2.938	5.250	EY 6.5-4-3691-1X
3	1810	2.143-41	2.938	5.250	EY 6.5-4-3691X
3	1810	2.143-41	2.938	5.250	EY 6.5-4-4601-1X
3	1810	2.143-41	2.938	5.250	EY 6.5-4-4601X

Pos	Series	Spline Data	Hub Dia	* to End of Hub	End Fitting Part Number
650					
1	1710	2.422-18	3.375	5.812	EY 6-4-4581
1	1710	2.422-18	3.375	5.812	EY 6-4-4581-1
1	1710	2.390-46	3.375	6.000	EY 6-4-7531-1X
1	1710	2.390-46	3.375	6.000	EY 6-4-7531X
1	1760	2.390-46	3.375	6.000	EY 6.3-4-1161-1X
1	1760	2.390-46	3.375	6.000	EY 6.3-4-1161X
1	1810	2.422-18	3.375	5.812	EY 6.5-4-1991
1	1810	2.422-18	3.375	5.812	EY 6.5-4-1991-1
1	1810	2.390-46	3.375	6.000	EY 6.5-4-3921-1X
1	1810	2.390-46	3.375	6.000	EY 6.5-4-3921X
2	1710	2.143-41	2.938	6.625	EY 6-4-7541 <i>High angle yoke</i>
2	1760	2.143-41	2.938	5.812	EY 6.3-4-1171
2	1810	2.143-41	2.938	5.812	EY 6.5-4-3931
3	1550	2.143-41	2.938	4.500	EY 4-4-5701-1X
3	1610	2.143-41	2.938	5.250	EY 5-4-7311-1X
3	1610	2.143-41	2.938	6.000	EY 5-4-7571X
3	1710	2.143-41	2.938	5.190	EY 6-4-7321-1X
3	1710	2.143-41	2.938	6.125	EY 6-4-7561X <i>High angle yoke</i>
3	1760	2.143-41	2.938	5.250	EY 6.3-4-1071-1X
3	1760	2.143-41	2.938	5.250	EY 6.3-4-1071X
3	1810	2.143-41	2.938	5.250	EY 6.5-4-3691X

*C/L to End of Hub for EY (End Yoke); Flange Face to End of Hub for CF (Companion Flange)

■ Hub machined for speedometer gear



Important: See Safety Information in General Information Section (J300P-GI)

TANDEM AXLES

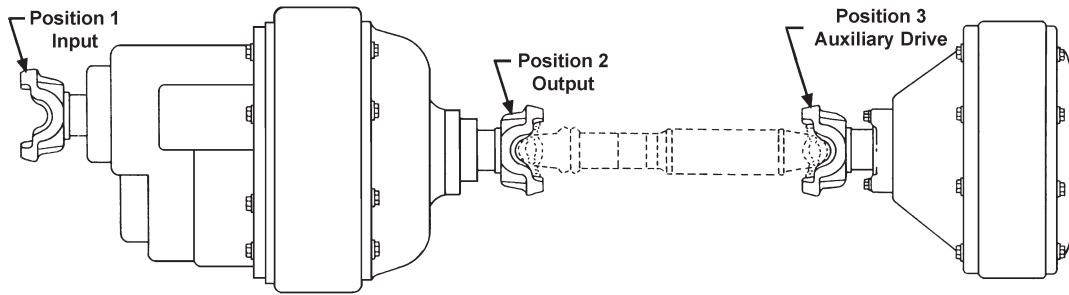

Pos	Series	Spline Data	Hub Dia	* to End of Hub	End Fitting Part Number
651					
1	SPL140	2.390-46	3.375	6.440	EY 140-4-381-1
1	SPL140	2.390-46	3.375	6.440	EY 140-4-391-1X
1	SPL170	2.390-46	3.375	6.531	EY 170-4-291-1
1	SPL170	2.390-46	3.375	6.531	EY 170-4-301-1X
1	SPL250	2.390-46	3.375	6.760	EY 250-4-101-1X
1	SPL250	2.390-46	3.375	6.760	EY 250-4-91-1
1	1550	2.143-41	2.938	4.500	EY 4-4-5581-1
1	1610	2.143-41	2.938	5.250	EY 5-4-7271-1
1	1610	2.143-41	2.938	6.000	EY 5-4-7561
1	1610	2.143-41	2.938	6.000	EY 5-4-7561-1
1	1610	2.143-41	2.938	5.250	EY 5-4-9111-1X
1	1610	2.143-41	2.938	6.000	EY 5-4-9121-1X
1	1610	2.143-41	2.938	6.000	EY 5-4-9121X
1	1710	2.390-46	3.375	6.000	EY 6-4-7511
1	1710	2.390-46	3.375	6.000	EY 6-4-7511-1
1	1710	2.390-46	3.375	6.000	EY 6-4-9201-1X
1	1760	2.143-41	2.938	5.250	EY 6.3-4-1061
1	1760	2.143-41	2.938	5.250	EY 6.3-4-1061-1
1	1760	2.390-46	3.375	6.000	EY 6.3-4-1151
1	1760	2.390-46	3.375	6.000	EY 6.3-4-1151-1
1	1760	2.143-41	2.938	5.250	EY 6.3-4-1631-1X
1	1760	2.390-46	3.375	6.000	EY 6.3-4-1651-1X
1	1760	2.390-46	3.375	6.000	EY 6.3-4-1651X
1	1810	2.390-46	3.375	6.000	EY 6.5-4-3911
1	1810	2.390-46	3.375	6.000	EY 6.5-4-3911-1
1	1810	2.390-46	3.375	6.000	EY 6.5-4-4611-1X
1	1810	2.390-46	3.375	6.000	EY 6.5-4-4611X
2	SPL170	2.143-41	2.938	7.190	EY 170-4-311-1
2	SPL170	2.143-41	2.938	7.190	EY 170-4-321-1X <i>High angle yoke</i>
2	SPL170	2.143-41	2.938	5.800	EY 170-4-331-1
2	SPL170	2.143-41	2.938	5.800	EY 170-4-341-1X
2	1610	2.143-41	2.938	6.500	EY 5-4-7551-1
2	1610	2.143-41	2.938	6.500	EY 5-4-9131-1X
2	1710	2.143-41	2.938	6.625	EY 6-4-7541-1 <i>High angle yoke</i>
2	1710	2.143-41	2.938	6.625	EY 6-4-9191-1X <i>High angle yoke</i>
2	1710	2.143-41	2.938	6.625	EY 6-4-9191X <i>High angle yoke</i>
2	1760	2.143-41	2.938	5.812	EY 6.3-4-1641X
2	1810	2.143-41	2.938	5.812	EY 6.5-4-4621X
3	1810	2.143-41	2.938	3.500	CF 6.5-1-2941
3	SPL140	2.143-41	2.938	5.560	EY 140-4-421-1
3	SPL140	2.143-41	2.938	5.560	EY 140-4-431-1X
3	SPL170	2.143-41	2.938	5.320	EY 170-4-351-1
3	SPL170	2.143-41	2.938	5.320	EY 170-4-361-1X
3	SPL170	2.143-41	2.938	6.680	EY 170-4-371-1 <i>High angle yoke</i>

Pos	Series	Spline Data	Hub Dia	* to End of Hub	End Fitting Part Number
651 (Continued)					
3	SPL170	2.143-41	2.938	6.680	EY 170-4-381-1X <i>High angle yoke</i>
3	SPL250	2.143-41	2.938	5.490	EY 250-4-131-1
3	SPL250	2.143-41	2.938	5.490	EY 250-4-141-1X
3	SPL90	2.143-41	2.938	4.562	EY 90-4-471-1
3	SPL90	2.143-41	2.938	4.562	EY 90-4-691-1X
3	1550	2.143-41	2.938	4.500	EY 4-4-5581-1
3	1610	2.143-41	2.938	6.000	EY 5-4-7571-1X
3	1610	2.143-41	2.938	5.250	EY 5-4-9111-1X
3	1610	2.143-41	2.938	6.000	EY 5-4-9121-1X
3	1610	2.143-41	2.938	6.000	EY 5-4-9121X
3	1710	2.143-41	2.938	5.190	EY 6-4-7311
3	1710	2.143-41	2.938	5.190	EY 6-4-7311-1
3	1710	2.143-41	2.938	6.125	EY 6-4-7551 <i>High angle yoke</i>
3	1710	2.143-41	2.938	6.125	EY 6-4-7551-1 <i>High angle yoke</i>
3	1710	2.143-41	2.938	5.190	EY 6-4-9171-1X
3	1710	2.143-41	2.938	5.190	EY 6-4-9171X
3	1710	2.143-41	2.938	6.125	EY 6-4-9181-1X <i>High angle yoke</i>
3	1710	2.143-41	2.938	6.125	EY 6-4-9181X <i>High angle yoke</i>
3	1760	2.143-41	2.938	5.250	EY 6.3-4-1631-1X
3	1810	2.143-41	2.938	5.250	EY 6.5-4-3681
3	1810	2.143-41	2.938	5.250	EY 6.5-4-3681-1
3	1810	2.143-41	2.938	5.250	EY 6.5-4-3691-1X
3	1810	2.143-41	2.938	5.250	EY 6.5-4-4601-1X
3	1810	2.143-41	2.938	5.250	EY 6.5-4-4601X
652					
1	SPL170	2.390-46	3.375	6.531	EY 170-4-301-1X
1	1710	2.390-46	3.375	6.000	EY 6-4-9201-1X
1	1760	2.390-46	3.375	6.000	EY 6.3-4-1651-1X
1	1760	2.390-46	3.375	6.000	EY 6.3-4-1651X
1	1810	2.390-46	3.375	6.000	EY 6.5-4-4611-1X
1	1810	2.390-46	3.375	6.000	EY 6.5-4-4611X
2	1710	2.143-41	2.938	6.625	EY 6-4-9191-1X <i>High angle yoke</i>
2	1710	2.143-41	2.938	6.625	EY 6-4-9191X <i>High angle yoke</i>
2	1810	2.143-41	2.938	5.812	EY 6.5-4-4621X
3	SPL170	2.143-41	2.938	5.320	EY 170-4-361-1X
3	1610	2.143-41	2.938	5.250	EY 5-4-9111-1X
3	1610	2.143-41	2.938	6.000	EY 5-4-9121X
3	1710	2.143-41	2.938	6.125	EY 6-4-9181-1X <i>High angle yoke</i>
3	1710	2.143-41	2.938	6.125	EY 6-4-9181X <i>High angle yoke</i>
3	1810	2.143-41	2.938	5.250	EY 6.5-4-4601X

*C/L to End of Hub for EY (End Yoke); Flange Face to End of Hub for CF (Companion Flange)

■ Hub machined for speedometer gear



Pos	Series	Spline Data	Hub Dia	* to End of Hub	End Fitting Part Number
701					
1	SPL140	2.390-46	3.375	6.440	EY 140-4-381-1
1	SPL140	2.390-46	3.375	6.440	EY 140-4-391-1X
1	SPL140	2.143-41	2.938	5.560	EY 140-4-421-1
1	SPL170	2.390-46	3.375	6.531	EY 170-4-291-1
1	SPL250	2.390-46	3.375	6.760	EY 250-4-101-1X
1	SPL250	2.390-46	3.375	6.760	EY 250-4-91-1
1	1550	2.143-41	2.938	4.500	EY 4-4-5581-1
1	1610	2.143-41	2.938	5.250	EY 5-4-7271-1
1	1610	2.143-41	2.938	6.000	EY 5-4-7561
1	1610	2.143-41	2.938	6.000	EY 5-4-7561-1
1	1610	2.143-41	2.938	5.250	EY 5-4-9111-1X
1	1610	2.143-41	2.938	6.000	EY 5-4-9121-1X
1	1610	2.143-41	2.938	6.000	EY 5-4-9121X
1	1710	2.390-46	3.375	6.000	EY 6-4-7511
1	1710	2.390-46	3.375	6.000	EY 6-4-7511-1
1	1710	2.143-41	2.938	6.625	EY 6-4-7541-1 <i>High angle yoke</i>
1	1710	2.390-46	3.375	6.000	EY 6-4-9201-1X
1	1760	2.143-41	2.938	5.250	EY 6.3-4-1061-1
1	1760	2.143-41	2.938	5.250	EY 6.3-4-1071-1X
1	1760	2.143-41	2.938	5.250	EY 6.3-4-1071X
1	1760	2.390-46	3.375	6.000	EY 6.3-4-1151
1	1760	2.390-46	3.375	6.000	EY 6.3-4-1151-1
1	1760	2.390-46	3.375	6.000	EY 6.3-4-1161-1X
1	1760	2.390-46	3.375	6.000	EY 6.3-4-1161X
1	1760	2.390-46	3.375	6.000	EY 6.3-4-1651-1X
1	1760	2.390-46	3.375	6.000	EY 6.3-4-1651X
1	1810	2.390-46	3.375	6.000	EY 6.5-4-3911
1	1810	2.390-46	3.375	6.000	EY 6.5-4-3911-1
1	1810	2.390-46	3.375	6.000	EY 6.5-4-3921-1X
1	1810	2.390-46	3.375	6.000	EY 6.5-4-3921X
1	1810	2.390-46	3.375	6.000	EY 6.5-4-4611-1X
1	1810	2.390-46	3.375	6.000	EY 6.5-4-4611X
2	SPL170	2.143-41	2.938	7.190	EY 170-4-311-1
2	SPL170	2.143-41	2.938	7.190	EY 170-4-321-1X <i>High angle yoke</i>
2	SPL170	2.143-41	2.938	5.800	EY 170-4-331-1
2	SPL170	2.143-41	2.938	5.800	EY 170-4-341-1X
2	SPL250	2.143-41	2.938	5.490	EY 250-4-131-1
2	SPL250	2.143-41	2.938	5.490	EY 250-4-141-1X
2	1610	2.143-41	2.938	6.500	EY 5-4-7551-1
2	1610	2.143-41	2.938	6.500	EY 5-4-9131-1X
2	1710	2.143-41	2.938	6.625	EY 6-4-7541 <i>High angle yoke</i>
2	1710	2.143-41	2.938	6.625	EY 6-4-7541-1 <i>High angle yoke</i>
2	1710	2.143-41	2.938	6.625	EY 6-4-9191-1X <i>High angle yoke</i>
2	1710	2.143-41	2.938	6.625	EY 6-4-9191X <i>High angle yoke</i>
2	1760	2.143-41	2.938	5.812	EY 6.3-4-1171
2	1760	2.143-41	2.938	5.812	EY 6.3-4-1641X
2	1810	2.143-41	2.938	5.812	EY 6.5-4-3931
2	1810	2.143-41	2.938	5.812	EY 6.5-4-4621X
3	1810	2.143-41	2.938	3.500	CF 6.5-1-2941
3	SPL140	2.143-41	2.938	5.560	EY 140-4-431-1X
3	SPL170	2.143-41	2.938	5.320	EY 170-4-351-1
3	SPL170	2.143-41	2.938	5.320	EY 170-4-361-1X
3	SPL170	2.143-41	2.938	6.680	EY 170-4-381-1X <i>High angle yoke</i>

Pos	Series	Spline Data	Hub Dia	* to End of Hub	End Fitting Part Number
701 (Continued)					
3	SPL90	2.143-41	2.938	4.562	EY 90-4-471-1
3	SPL90	2.143-41	2.938	4.562	EY 90-4-691-1X
3	1550	2.143-41	2.938	4.500	EY 4-4-5581-1
3	1610	2.143-41	2.938	6.000	EY 5-4-7571-1X
3	1610	2.143-41	2.938	6.000	EY 5-4-7571X
3	1710	2.143-41	2.938	5.190	EY 6-4-7311
3	1710	2.143-41	2.938	5.190	EY 6-4-7311-1
3	1710	2.143-41	2.938	5.190	EY 6-4-7321-1X
3	1710	2.143-41	2.938	6.125	EY 6-4-7551 <i>High angle yoke</i>
3	1710	2.143-41	2.938	6.125	EY 6-4-7551-1 <i>High angle yoke</i>
3	1710	2.143-41	2.938	6.125	EY 6-4-7561-1X <i>High angle yoke</i>
3	1710	2.143-41	2.938	6.125	EY 6-4-7561X <i>High angle yoke</i>
3	1710	2.143-41	2.938	5.190	EY 6-4-9171-1X
3	1710	2.143-41	2.938	5.190	EY 6-4-9171X
3	1710	2.143-41	2.938	6.125	EY 6-4-9181-1X <i>High angle yoke</i>
3	1710	2.143-41	2.938	6.125	EY 6-4-9181X <i>High angle yoke</i>
3	1760	2.143-41	2.938	5.250	EY 6.3-4-1071X
3	1810	2.143-41	2.938	5.250	EY 6.5-4-3681
3	1810	2.143-41	2.938	5.250	EY 6.5-4-3681-1
3	1810	2.143-41	2.938	5.250	EY 6.5-4-3691-1X
3	1810	2.143-41	2.938	5.250	EY 6.5-4-3691X
3	1810	2.143-41	2.938	5.250	EY 6.5-4-4601-1X
3	1810	2.143-41	2.938	5.250	EY 6.5-4-4601X

Pos	Series	Spline Data	Hub Dia	* to End of Hub	End Fitting Part Number
22060SH					
1	1610	2.274-44	3.000	5.000	EY 5-4-9261-1X
1	1710	2.274-44	3.000	5.190	EY 6-4-8451
1	1710	2.274-44	3.000	5.190	EY 6-4-8981-1X
1	1760	2.274-44	3.000	5.250	EY 6.3-4-5221-1X
1	1760	2.274-44	3.000	5.250	EY 6.3-4-5221X
1	1810	2.274-44	3.000	5.250	EY 6.5-4-4571-1X
1	1810	2.274-44	3.000	5.250	EY 6.5-4-4571X
2	1610	2.024-39	2.625	6.000	EY 5-4-9271X <i>High angle yoke</i>
2	1710	2.024-39	2.625	6.125	EY 6-4-9001-1X
2	1710	2.024-39	2.625	6.125	EY 6-4-9001X
2	1710	2.024-39	2.625	5.250	EY 6-4-9041-1X
2	1710	2.024-39	2.625	5.250	EY 6-4-9041X
3	1480	2.024-39	3.000	4.344	EY 3-4-13081-1X
3	1550	2.024-39	3.000	4.281	EY 4-4-7571-1X
3	1610	2.024-39	3.000	6.000	EY 5-4-9241X <i>High angle yoke</i>
3	1710	2.024-39	3.000	6.125	EY 6-4-8991-1X <i>High angle yoke</i>
3	1710	2.024-39	3.000	6.125	EY 6-4-8991X <i>High angle yoke</i>
3	1710	2.024-39	3.000	5.250	EY 6-4-9031-1X
3	1710	2.024-39	3.000	5.250	EY 6-4-9031X

*C/L to End of Hub for EY (End Yoke); Flange Face to End of Hub for CF (Companion Flange)

■ Hub machined for speedometer gear



Important: See Safety Information in General Information Section (J300P-GI)

TANDEM AXLES

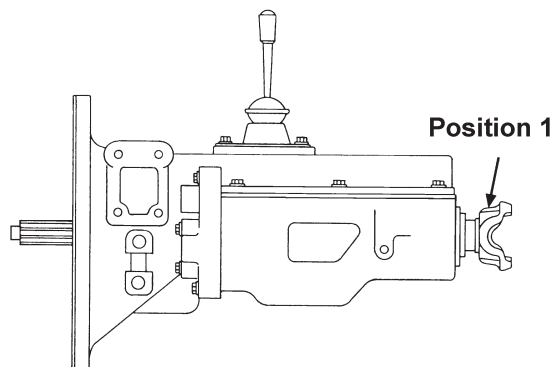

Pos	Series	Spline Data	Hub Dia	* to End of Hub	End Fitting Part Number
-----	--------	-------------	---------	-----------------	-------------------------

AT-540

1	1480/1550	1.790-34	2.562	3.344	CF 4-1-4471 <i>Assy includes plug 231059 and 4 studs 231016</i>
1	1480/1550	1.790-34	2.562	3.344	CF 4-1-4481X <i>Assy includes plug 231059 and 4 studs 231016</i>
1	1480/1550	1.790-34	2.562	3.344	CF 4-1-4491 <i>Assy includes plug 231059</i>
1	1480/1550	1.790-34	2.562	3.344	CF 4-1-4501X <i>Assy includes plug 231059</i>
1	1610/SPL90	1.790-34	2.562	3.719	CF 90-1-11 <i>Assy includes plug 231059 and eight 6-73-725 bolts</i>
1	1610/SPL90	1.790-34	2.562	3.719	CF 90-1-21X <i>Assy includes plug 231059 and eight 6-73-725 bolts</i>
1	SPL70	1.790-34	2.564	5.530	EY 70-4-181-1 <i>Can be used w/brake; Flanged yoke w/eight, 7-73-620 bolts</i>
1	SPL70	1.790-34	2.564	5.530	EY 70-4-191-1X <i>Can be used w/brake; Flanged yoke w/eight, 7-73-620 bolts</i>
1	SPL90	1.790-34	2.562	5.625	EY 90-4-461-1 <i>Can be used w/brake</i>
1	SPL90	1.790-34	2.562	5.625	EY 90-4-501-1X <i>Can be used w/brake</i>
1	1480	1.790-34	2.567	4.885	EY 3-4-11551-1 <i>Can be used w/brake</i>
1	1480	1.790-34	2.567	4.885	EY 3-4-11621-1X <i>Flanged end yoke, strap kit not furnished by Dana</i>
1	1480	1.790-34	2.562	5.125	EY 3-4-9231-1 <i>Can be used w/brake</i>
1	1480	1.790-34	2.562	5.125	EY 3-4-9241-1X <i>Can be used w/brake</i>
1	1480	1.790-34	2.562	5.125	EY 3-4-9241-2X <i>Attaching hardware by OEM</i>
1	1550	1.790-34	2.562	5.156	EY 4-4-4791-1 <i>Can be used w/brake</i>
1	1550	1.790-34	2.562	5.156	EY 4-4-4801-1X <i>Can be used w/brake</i>
1	1610	1.790-34	2.567	5.310	EY 5-4-5231X
1	1610	1.790-34	2.562	5.312	EY 5-4-7781-1
1	1610	1.790-34	2.562	5.312	EY 5-4-8061-1X

AT-542

1	1480/1550	1.790-34	2.562	3.344	CF 4-1-4471 <i>Assy includes plug 231059 and 4 studs 231016</i>
1	1480/1550	1.790-34	2.562	3.344	CF 4-1-4481X <i>Assy includes plug 231059 and 4 studs 231016</i>
1	1480/1550	1.790-34	2.562	3.344	CF 4-1-4491 <i>Assy includes plug 231059</i>

Pos	Series	Spline Data	Hub Dia	* to End of Hub	End Fitting Part Number
-----	--------	-------------	---------	-----------------	-------------------------

AT-542 (Continued)

1	1480/1550	1.790-34	2.562	3.344	CF 4-1-4501X <i>Assy includes plug 231059</i>
1	1610/SPL90	1.790-34	2.562	3.719	CF 90-1-11 <i>Assy includes plug 231059 & eight 6-73-725 bolts</i>
1	1610/SPL90	1.790-34	2.562	3.719	CF 90-1-21X <i>Assy includes plug 231059 & eight 6-73-725 bolts</i>
1	SPL90	1.790-34	2.562	5.625	EY 90-4-461-1
1	SPL90	1.790-34	2.562	5.625	EY 90-4-501-1X
1	1480	1.790-34	2.567	4.885	EY 3-4-11551-1 <i>Flanged end yoke, strap kit not furnished by Dana</i>
1	1480	1.790-34	2.567	4.885	EY 3-4-11621-1X <i>Flanged end yoke, strap kit not furnished by Dana</i>
1	1480	1.790-34	2.562	5.125	EY 3-4-9231-1
1	1480	1.790-34	2.562	5.125	EY 3-4-9241-1X
1	1550	1.790-34	2.562	5.156	EY 4-4-4791-1
1	1550	1.790-34	2.562	5.156	EY 4-4-4801-1X
1	1610	1.790-34	2.562	5.312	EY 5-4-7781-1
1	1610	1.790-34	2.562	5.312	EY 5-4-8061-1X

AT-543

1	1480/1550	1.790-34	2.562	3.344	CF 4-1-4471 <i>Assy includes plug 231059 & 4 studs 231016</i>
1	1480/1550	1.790-34	2.562	3.344	CF 4-1-4481X <i>Assy includes plug 231059 & 4 studs 231016</i>
1	1480/1550	1.790-34	2.562	3.344	CF 4-1-4491 <i>Assy includes plug 231059</i>
1	1480/1550	1.790-34	2.562	3.344	CF 4-1-4501X <i>Assy includes plug 231059</i>
1	1610/SPL90	1.790-34	2.562	3.719	CF 90-1-11 <i>Assy includes plug 231059 & eight 6-73-725 bolts</i>
1	1610/SPL90	1.790-34	2.562	3.719	CF 90-1-21X <i>Assy includes plug 231059 & eight 6-73-725 bolts</i>
1	SPL90	1.790-34	2.562	5.625	EY 90-4-461-1
1	SPL90	1.790-34	2.562	5.625	EY 90-4-501-1X
1	1480	1.790-34	2.567	4.885	EY 3-4-11551-1 <i>Flanged end yoke, strap kit not furnished by Dana</i>
1	1480	1.790-34	2.567	4.885	EY 3-4-11621-1X <i>Flanged end yoke, strap kit not furnished by Dana</i>
1	1480	1.790-34	2.562	5.125	EY 3-4-9231-1
1	1480	1.790-34	2.562	5.125	EY 3-4-9241-1X
1	1480	1.790-34	2.562	5.125	EY 3-4-9241-2X <i>Attaching hardware by OEM</i>
1	1550	1.790-34	2.562	5.156	EY 4-4-4791-1
1	1550	1.790-34	2.562	5.156	EY 4-4-4801-1X
1	1610	1.790-34	2.567	5.310	EY 5-4-5231X
1	1610	1.790-34	2.562	5.312	EY 5-4-7781-1
1	1610	1.790-34	2.562	5.312	EY 5-4-8061-1X

*C/L to End of Hub for EY (End Yoke); Flange Face to End of Hub for CF (Companion Flange)

■ Hub machined for speedometer gear



Pos	Series	Spline Data	Hub Dia	* to End of Hub	End Fitting Part Number
AT-545					
1	1480/1550	1.790-34	2.562	3.344	CF 4-1-4471 <i>Assy includes plug 231059 & 4 studs 231016</i>
1	1480/1550	1.790-34	2.562	3.344	CF 4-1-4481X <i>Can be used w/brake; Assy includes plug 231059 & 4 studs 231016</i>
1	1480/1550	1.790-34	2.562	3.344	CF 4-1-4491 <i>Assy includes plug 231059</i>
1	1480/1550	1.790-34	2.562	3.344	CF 4-1-4501X <i>Assy includes plug 231059</i>
1	1610/SPL90	1.790-34	2.562	3.719	CF 90-1-11 <i>Can be used w/brake; Assy includes plug 231059 & eight 6-73-725 bolts</i>
1	1610/SPL90	1.790-34	2.562	3.719	CF 90-1-21X <i>Can be used w/brake; Assy includes plug 231059 & eight 6-73-725 bolts</i>
1	SPL55	1.790-34	2.564	4.870	EY 5001480
1	SPL55	1.790-34	2.564	4.870	EY 55-4-101-1X <i>For 9" x 3" Brake</i>
1	SPL55	1.790-34	2.564	4.870	EY 55-4-91-1 <i>For 9" x 3" Brake</i>
1	SPL90	1.790-34	2.562	5.625	EY 90-4-461-1
1	SPL90	1.790-34	2.562	5.625	EY 90-4-501-1X
1	1480	1.790-34	2.567	4.885	EY 3-4-11551-1 <i>Flanged end yoke, strap kit not furnished by Dana</i>
1	1480	1.790-34	2.567	4.885	EY 3-4-11621-1X <i>Flanged end yoke, strap kit not furnished by Dana</i>
1	1480	1.790-34	2.562	5.125	EY 3-4-9231-1
1	1480	1.790-34	2.562	5.125	EY 3-4-9241-1X
1	1480	1.790-34	2.562	5.125	EY 3-4-9241-2X <i>Attaching hardware by OEM</i>
1	1550	1.790-34	2.562	5.156	EY 4-4-4791-1
1	1550	1.790-34	2.562	5.156	EY 4-4-4801-1X
1	1610	1.790-34	2.567	5.310	EY 5-4-5231X
1	1610	1.790-34	2.562	5.312	EY 5-4-7781-1
1	1610	1.790-34	2.562	5.312	EY 5-4-8061-1X
AT-1542					
1	1480/1550	1.790-34	2.562	3.344	CF 4-1-4471 <i>Assy includes plug 231059 & 4 studs 231016</i>
1	1480/1550	1.790-34	2.562	3.344	CF 4-1-4481X <i>Assy includes plug 231059 & 4 studs 231016</i>
1	1480/1550	1.790-34	2.562	3.344	CF 4-1-4491 <i>Assy includes plug 231059</i>
1	1480/1550	1.790-34	2.562	3.344	CF 4-1-4501X <i>Assy includes plug 231059</i>
1	1610/SPL90	1.790-34	2.562	3.719	CF 90-1-11 <i>Assy includes plug 231059 & eight 6-73-725 bolts</i>
1	1610/SPL90	1.790-34	2.562	3.719	CF 90-1-21X <i>Assy includes plug 231059 & eight 6-73-725 bolts</i>
1	SPL90	1.790-34	2.562	5.625	EY 90-4-461-1
1	SPL90	1.790-34	2.562	5.625	EY 90-4-501-1X
1	1480	1.790-34	2.567	4.885	EY 3-4-11551-1 <i>Flanged end yoke, strap kit not furnished by Dana</i>
1	1480	1.790-34	2.567	4.885	EY 3-4-11621-1X <i>Flanged end yoke, strap kit not furnished by Dana</i>
1	1480	1.790-34	2.562	5.125	EY 3-4-9231-1
1	1480	1.790-34	2.562	5.125	EY 3-4-9241-1X
1	1550	1.790-34	2.562	5.156	EY 4-4-4791-1
1	1550	1.790-34	2.562	5.156	EY 4-4-4801-1X
1	1610	1.790-34	2.562	5.312	EY 5-4-7781-1
1	1610	1.790-34	2.562	5.312	EY 5-4-8061-1X
AT-1543					
1	1480/1550	1.790-34	2.562	3.344	CF 4-1-4471 <i>Assy includes plug 231059 & 4 studs 231016</i>
1	1480/1550	1.790-34	2.562	3.344	CF 4-1-4481X <i>Assy includes plug 231059 & 4 studs 231016</i>

Pos	Series	Spline Data	Hub Dia	* to End of Hub	End Fitting Part Number
AT-1543 (Continued)					
1	1480/1550	1.790-34	2.562	3.344	CF 4-1-4491 <i>Assy includes plug 231059</i>
1	1480/1550	1.790-34	2.562	3.344	CF 4-1-4501X <i>Assy includes plug 231059</i>
1	1610/SPL90	1.790-34	2.562	3.719	CF 90-1-11 <i>Assy includes plug 231059 & eight 6-73-725 bolts</i>
1	1610/SPL90	1.790-34	2.562	3.719	CF 90-1-21X <i>Assy includes plug 231059 & eight 6-73-725 bolts</i>
1	SPL90	1.790-34	2.562	5.625	EY 90-4-461-1
1	SPL90	1.790-34	2.562	5.625	EY 90-4-501-1X
1	1480	1.790-34	2.567	4.885	EY 3-4-11551-1 <i>Flanged end yoke, strap kit not furnished by Dana</i>
1	1480	1.790-34	2.567	4.885	EY 3-4-11621-1X <i>Flanged end yoke, strap kit not furnished by Dana</i>
1	1480	1.790-34	2.562	5.125	EY 3-4-9231-1
1	1480	1.790-34	2.562	5.125	EY 3-4-9241-1X
1	1550	1.790-34	2.562	5.156	EY 4-4-4791-1
1	1550	1.790-34	2.562	5.156	EY 4-4-4801-1X
1	1610	1.790-34	2.562	5.312	EY 5-4-7781-1
1	1610	1.790-34	2.562	5.312	EY 5-4-8061-1X
AT-1545					
1	1480/1550	1.790-34	2.562	3.344	CF 4-1-4471 <i>Assy includes plug 231059 & 4 studs 231016</i>
1	1480/1550	1.790-34	2.562	3.344	CF 4-1-4481X <i>Assy includes plug 231059 & 4 studs 231016</i>
1	1480/1550	1.790-34	2.562	3.344	CF 4-1-4491 <i>Assy includes plug 231059</i>
1	1480/1550	1.790-34	2.562	3.344	CF 4-1-4501X <i>Assy includes plug 231059</i>
1	1610/SPL90	1.790-34	2.562	3.719	CF 90-1-11 <i>Assy includes plug 231059 & eight 6-73-725 bolts</i>
1	1610/SPL90	1.790-34	2.562	3.719	CF 90-1-21X <i>Assy includes plug 231059 & eight 6-73-725 bolts</i>
1	SPL90	1.790-34	2.562	5.625	EY 90-4-461-1
1	SPL90	1.790-34	2.562	5.625	EY 90-4-501-1X
1	1480	1.790-34	2.567	4.885	EY 3-4-11551-1 <i>Flanged end yoke, strap kit not furnished by Dana</i>
1	1480	1.790-34	2.567	4.885	EY 3-4-11621-1X <i>Flanged end yoke, strap kit not furnished by Dana</i>
1	1480	1.790-34	2.562	5.125	EY 3-4-9231-1
1	1480	1.790-34	2.562	5.125	EY 3-4-9241-1X
1	1550	1.790-34	2.562	5.156	EY 4-4-4791-1
1	1550	1.790-34	2.562	5.156	EY 4-4-4801-1X
1	1610	1.790-34	2.562	5.312	EY 5-4-7781-1
1	1610	1.790-34	2.562	5.312	EY 5-4-8061-1X
B-300, B-400					
1	SPL140	2.178-43	3.539	5.100	EY 140-4-761-1
1	SPL170	2.178-43	3.540	5.340	EY 170-4-1081-1
1	SPL90	2.178-43	3.547	4.625	EY 90-4-791-1
1	1610	2.178-43	3.531	5.406	EY 5-4-9141
1	1610	2.178-43	3.531	5.406	EY 5-4-9141-1
1	1710	2.178-43	3.539	4.875	EY 6-4-9221-1
1	1760	2.178-43	3.539	5.500	EY 6.3-4-1591-1
CLBT-750					
1	1810	2.560-20	3.500	4.000	CF 6.5-1-2161
1	1810	2.560-20	3.500	6.125	EY 6.5-4-3361
1	1810	2.560-20	3.500	6.125	EY 6.5-4-3361-1
CLBT-5000					
1	1610	2.359-18	3.000	5.219	EY 5-4-2341

*C/L to End of Hub for EY (End Yoke); Flange Face to End of Hub for CF (Companion Flange)

■ Hub machined for speedometer gear



Important: See Safety Information in General Information Section (J300P-GI)

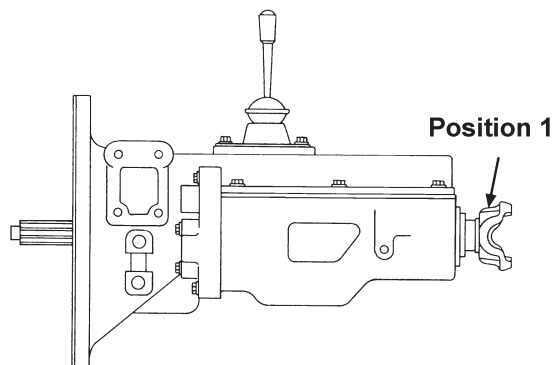

Pos	Series	Spline Data	Hub Dia	* to End of Hub	End Fitting Part Number
CLBT-5961, CLBT-5962					
1	1610	1.962-10	3.000	4.750	EY 5-4-2531 <i>C'bore depth is chamfered</i>
CLBT-6000					
1	1610	2.359-18	3.000	5.219	EY 5-4-2341
CLBT-6061, CLBT-6062					
1	1610	1.962-10	3.000	4.750	EY 5-4-2531 <i>C'bore depth is chamfered</i>
CLBT-7000					
1	1610	2.359-18	3.000	5.219	EY 5-4-2341
CLT-700					
1	1810	2.560-20	3.500	4.000	CF 6.5-1-2161
1	1810	2.560-20	3.500	6.125	EY 6.5-4-3361
1	1810	2.560-20	3.500	6.125	EY 6.5-4-3361-1
CLT-750					
1	1610	2.359-18	3.000	5.219	EY 5-4-2341
CLT-750HD					
1	1810	2.560-20	3.500	4.000	CF 6.5-1-2161
1	1810	2.560-20	3.500	6.125	EY 6.5-4-3361
CLT-5000, CLT-6000, CLT-7000, CRT-5000, CRT-6000, CRT-7000					
1	1610	2.359-18	3.000	5.219	EY 5-4-2341
HD (ALL)					
1	SPL140	2.795-55	4.725	4.980	EY 140-4-771-1
1	SPL170	2.795-55	4.725	5.200	EY 170-4-1091-1
1	SPL250	2.795-55	4.725	5.413	EY 250-4-501-1
1	SPL250	2.795-55	4.725	5.410	EY 250-4-941-1 <i>With 231059 plug. Attaching hardware by OEM; OEM only</i>
1	SPL250	2.795-55	4.725	5.410	EY 250-4-951-1X <i>With 231059 plug. Attaching hardware by OEM; OEM only</i>
1	SPL350	2.795-55	4.724	5.688	EY 350-4-151-1
1	SPL350	2.795-55	4.724	5.688	EY 350-4-161-1X
1	1760	2.795-55	4.725	5.000	EY 6.3-4-1761-1 <i>With 231059 plug. Attaching hardware by OEM</i>
HT-700CT					
1	1650/1710	2.364-18	3.500	4.031	CF 6-1-4541
1	1810	2.364-18	3.500	4.031	CF 6.5-1-1801
1	SPL170	2.364-18	3.500	6.350	EY 170-4-1061-1
1	1710	2.364-18	3.500	5.750	EY 6-4-4561
1	1710	2.364-18	3.500	5.750	EY 6-4-4561-1
1	1760	2.364-18	3.500	6.125	EY 6.3-4-271-1
1	1810	2.364-18	3.500	6.125	EY 6.5-4-2581
1	1810	2.364-18	3.500	6.125	EY 6.5-4-2581-1

Pos	Series	Spline Data	Hub Dia	* to End of Hub	End Fitting Part Number
HT-704D					
1	SPL170	2.364-18	3.500	6.350	EY 170-4-1061-1
1	1810	2.364-18	3.500	6.125	EY 6.5-4-2581
HT-740					
1	1650/1710	2.364-18	3.500	4.031	CF 6-1-4541
1	1810	2.364-18	3.500	4.031	CF 6.5-1-1801
1	SPL170	2.364-18	3.500	6.350	EY 170-4-1061-1
1	1710	2.364-18	3.500	5.750	EY 6-4-4561
1	1710	2.364-18	3.500	5.750	EY 6-4-4561-1
1	1760	2.364-18	3.500	6.125	EY 6.3-4-271
1	1760	2.364-18	3.500	6.125	EY 6.3-4-271-1
1	1810	2.364-18	3.500	6.125	EY 6.5-4-2581
1	1810	2.364-18	3.500	6.125	EY 6.5-4-2581-1
HT-740D					
1	1650/1710	2.364-18	3.500	4.031	CF 6-1-4541
1	1810	2.364-18	3.500	4.031	CF 6.5-1-1801
1	SPL170	2.364-18	3.500	6.350	EY 170-4-1061-1
HT-750					
1	1650/1710	2.364-18	3.500	4.031	CF 6-1-4541
1	1810	2.364-18	3.500	4.031	CF 6.5-1-1801
1	SPL170	2.364-18	3.500	6.350	EY 170-4-1061-1
1	1710	2.364-18	3.500	5.750	EY 6-4-4561
1	1710	2.364-18	3.500	5.750	EY 6-4-4561-1
1	1760	2.364-18	3.500	6.125	EY 6.3-4-271
1	1760	2.364-18	3.500	6.125	EY 6.3-4-271-1
1	1810	2.364-18	3.500	6.125	EY 6.5-4-2581
1	1810	2.364-18	3.500	6.125	EY 6.5-4-2581-1
HT-750D					
1	1650/1710	2.364-18	3.500	4.031	CF 6-1-4541
1	1810	2.364-18	3.500	4.031	CF 6.5-1-1801
1	SPL170	2.364-18	3.500	6.350	EY 170-4-1061-1
1	1710	2.364-18	3.500	5.750	EY 6-4-4561
1	1810	2.364-18	3.500	6.125	EY 6.5-4-2581
HTB-700, HTB-740					
1	1810	2.364-18	2.750	3.000	CF 6.5-1-2301
1	1710	2.364-18	3.750	5.094	EY 6-4-6971■
1	1710	2.364-18	3.750	5.094	EY 6-4-6971-1■
HTB-741					
1	1810	2.364-18	2.750	3.000	CF 6.5-1-2301
1	1710	2.364-18	3.750	5.094	EY 6-4-6971■
1	1710	2.364-18	3.750	5.094	EY 6-4-6971-1■
1	1810	2.364-18	3.750	5.625	EY 6.5-4-4211-1■ <i>Fits trans w/retarder</i>

*C/L to End of Hub for EY (End Yoke); Flange Face to End of Hub for CF (Companion Flange)

■ Hub machined for speedometer gear



Pos	Series	Spline Data	Hub Dia	* to End of Hub	End Fitting Part Number
HTB-745, HTB-746					
1	1810	2.364-18	2.750	3.000	CF 6.5-1-2301
1	1710	2.364-18	3.750	5.094	EY 6-4-6971■
1	1710	2.364-18	3.750	5.094	EY 6-4-6971-1■
HTB-781					
1	1810	2.364-18	2.750	3.000	CF 6.5-1-2301
1	1710	2.364-18	3.750	5.094	EY 6-4-6971■
1	1710	2.364-18	3.750	5.094	EY 6-4-6971-1■
1	1810	2.364-18	3.750	5.625	EY 6.5-4-4211-1■ <i>Fits trans w/retarder</i>
LCT1000 ALL, LCT2000 ALL					
1	SPL90	1.790-34	2.562	3.719	CF 90-1-21X <i>Assy includes plug 231059 & eight 6-73-725 bolts</i>
1	1480/1550	1.790-34	2.562	3.344	CF 4-1-4471 <i>Assy includes plug 231059 & 4 studs 231016</i>
1	1480/1550	1.790-34	2.562	3.344	CF 4-1-4481X <i>Assy includes plug 231059 & 4 studs 231016</i>
1	1480/1550	1.790-34	2.562	3.344	CF 4-1-4501X <i>Assy includes plug 231059</i>
1	SPL90	1.790-34	2.562	5.625	EY 90-4-501-1X
1	1480	1.790-34	2.567	4.885	EY 3-4-11621-1X <i>Flanged end yoke, strap kit not furnished by Dana</i>
1	1480	1.790-34	2.562	5.125	EY 3-4-9241-1X
1	1550	1.790-34	2.562	5.156	EY 4-4-4801-1X
1	1610	1.790-34	2.562	5.312	EY 5-4-8061-1X
MD (ALL)					
1	SPL140	2.178-43	3.541	5.100	EY 140-4-1231-1
1	SPL140	2.178-43	3.539	5.100	EY 140-4-761-1
1	SPL170	2.178-43	3.540	5.340	EY 170-4-1081-1
1	SPL90	2.178-43	3.547	4.625	EY 90-4-791-1
1	1610	2.178-43	3.531	5.406	EY 5-4-9141
1	1610	2.178-43	3.531	5.406	EY 5-4-9141-1
1	1710	2.178-43	3.539	4.875	EY 6-4-9221
1	1710	2.178-43	3.539	4.875	EY 6-4-9221-1
MT-63					
1	SPL55	1.790-34	2.564	4.870	EY 5001480
MT-545					
1	1710	1.790-34	2.562	5.594	EY 6-4-5031-1
1	1710	1.790-34	2.562	5.594	EY 6-4-5041-1X
MT-640, MT-643, MT-644					
1	1610	1.790-34	2.562	3.938	CF 5-1-5111 <i>Assy includes plug 231059</i>
1	1610	1.790-34	2.562	3.938	CF 5-1-5121X <i>Assy includes plug 231059</i>
1	1610	1.790-34	2.562	4.250	CF 5-1-5141 <i>Assy includes plug 231059 & eight 6-73-725 bolts</i>
1	1610	1.790-34	2.562	4.250	CF 5-1-5151X <i>Assy includes plug 231059 & eight 6-73-725 bolts</i>
1	1710	1.790-34	2.562	3.903	CF 6-1-4691 <i>Assy includes plug 231059</i>
1	1710	1.790-34	2.562	3.903	CF 6-1-4701X <i>Assy includes plug 231059</i>
1	SPL140	1.790-34	2.564	5.720	EY 140-4-741-1X
1	SPL90	1.790-34	2.562	5.609	EY 90-4-181-1
1	SPL90	1.790-34	2.562	5.609	EY 90-4-191-1X
1	1550	1.790-34	2.562	5.125	EY 4-4-3851-1
1	1550	1.790-34	2.562	5.125	EY 4-4-3861-1X
1	1610	1.790-34	2.562	5.312	EY 5-4-4831
1	1610	1.790-34	2.562	5.312	EY 5-4-4831-1
1	1610	1.790-34	2.562	5.312	EY 5-4-4841-1X

Pos	Series	Spline Data	Hub Dia	* to End of Hub	End Fitting Part Number
MT-640, MT-643, MT-644 (Continued)					
1	1610	1.790-34	2.562	5.312	EY 5-4-4841X
1	1710	1.790-34	2.562	5.594	EY 6-4-5031-1
1	1710	1.790-34	2.562	5.594	EY 6-4-5041-1X
1	1710	1.790-34	2.562	7.188	EY 6-4-5041X <i>High angle yoke</i>
MT-646					
1	1610	1.790-34	2.562	5.312	EY 5-4-4841-1X
MT-647, MT-648					
1	1610	1.790-34	2.562	3.938	CF 5-1-5111 <i>Assy includes plug 231059</i>
1	1610	1.790-34	2.562	3.938	CF 5-1-5121X <i>Assy includes plug 231059</i>
1	1610	1.790-34	2.562	4.250	CF 5-1-5141 <i>Assy includes plug 231059 & eight 6-73-725 bolts</i>
1	1610	1.790-34	2.562	4.250	CF 5-1-5151X <i>Assy includes plug 231059 & eight 6-73-725 bolts</i>
1	1710	1.790-34	2.562	3.903	CF 6-1-4691 <i>Assy includes plug 231059</i>
1	1710	1.790-34	2.562	3.903	CF 6-1-4701X <i>Assy includes plug 231059</i>
1	SPL140	1.790-34	2.564	5.720	EY 140-4-741-1X
1	SPL90	1.790-34	2.562	5.609	EY 90-4-181-1
1	SPL90	1.790-34	2.562	5.609	EY 90-4-191-1X
1	1550	1.790-34	2.562	5.125	EY 4-4-3851-1
1	1550	1.790-34	2.562	5.125	EY 4-4-3861-1X
1	1610	1.790-34	2.562	5.312	EY 5-4-4831
1	1610	1.790-34	2.562	5.312	EY 5-4-4831-1
1	1610	1.790-34	2.562	5.312	EY 5-4-4841-1X
1	1710	1.790-34	2.562	5.594	EY 6-4-5031-1
1	1710	1.790-34	2.562	5.594	EY 6-4-5041-1X
1	1710	1.790-34	2.562	7.188	EY 6-4-5041X <i>High angle yoke</i>
MT-650, MT-653					
1	1710	2.390-46	3.500	4.547	CF 6-1-4671
1	SPL140	2.390-46	3.500	5.920	EY 140-4-751-1
1	SPL250	2.390-46	3.500	6.560	EY 250-4-471-1
1	1610	2.390-46	3.500	6.125	EY 5-4-4861 <i>Can be used w/brake</i>
1	1610	2.390-46	3.500	6.125	EY 5-4-4861-1
1	1710	2.390-46	3.500	5.750	EY 6-4-4771
1	1710	2.390-46	3.500	5.750	EY 6-4-4771-1
1	1760	2.390-46	3.500	6.000	EY 6.3-4-381
1	1760	2.390-46	3.500	6.000	EY 6.3-4-381-1
1	1810	2.390-46	3.500	6.156	EY 6.5-4-2541
1	1810	2.390-46	3.500	6.156	EY 6.5-4-2541-1
MT-654					
1	1710	2.390-46	3.500	4.547	CF 6-1-4671
1	SPL140	2.390-46	3.500	5.920	EY 140-4-751-1
1	SPL250	2.390-46	3.500	6.560	EY 250-4-471-1
1	1610	2.390-46	3.500	6.125	EY 5-4-4861
1	1610	2.390-46	3.500	6.125	EY 5-4-4861-1
1	1710	2.390-46	3.500	5.750	EY 6-4-4771-1
1	1760	2.390-46	3.500	6.000	EY 6.3-4-381
1	1760	2.390-46	3.500	6.000	EY 6.3-4-381-1
1	1810	2.390-46	3.500	6.156	EY 6.5-4-2541
1	1810	2.390-46	3.500	6.156	EY 6.5-4-2541-1

*C/L to End of Hub for EY (End Yoke); Flange Face to End of Hub for CF (Companion Flange)

■ Hub machined for speedometer gear



Important: See Safety Information in General Information Section (J300P-GI)

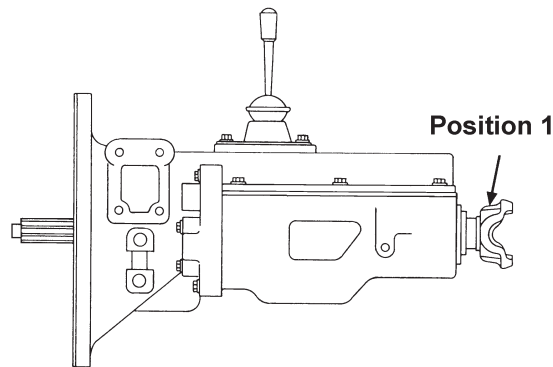

Pos	Series	Spline Data	Hub Dia	* to End of Hub	End Fitting Part Number
-----	--------	-------------	---------	-----------------	-------------------------

ALLISON

MT-654CR					
1	1710	2.390-46	3.500	4.547	CF 6-1-4671
1	1610	2.390-46	3.500	6.125	EY 5-4-4861
<i>Can be used w/brake</i>					
1	1710	2.390-46	3.500	5.750	EY 6-4-4771
1	1810	2.390-46	3.500	6.156	EY 6.5-4-2541

MTB-644, MTB-654					
1	1810	2.364-18	3.750	5.625	EY 6.5-4-4211-1 ■ <i>Fits trans w/retarder</i>

TC-10					
1	SPL350	2.795-55	4.724	5.688	EY 350-4-161-1X

1000, 2000					
1	SPL070	1.790-34	2.562	6.650	EY 5001789 <i>Flanged yoke w/four holes in flange</i>
1	SPL55	1.790-34	2.564	4.870	EY 5001480
1	SPL70	1.790-34	2.562	6.650	EY 70-4-01789-1X <i>Flanged yoke w/four holes in flange</i>

5000, 6000					
1	1710	3.003-23	4.000	4.844	EY 6-4-3141

10001					
1	SPL70	1.790-34	2.564	5.530	EY 70-4-181-1 <i>Can be used w/brake; Flanged yoke w/eight 7-73-620 bolts</i>
1	SPL70	1.790-34	2.564	5.530	EY 70-4-191-1X <i>Can be used w/brake Flanged yoke w/eight 7-73-620 bolts</i>

CATERPILLAR

CX-31					
1	SPL350	3.046-48	4.251	5.256	EY 350-4-171-1

CLARK

CL-450					
1	1480/1550	1.750-10	2.500	2.734	CF 4-1-5131
1	1480/1550	1.750-10	2.500	3.547	CF 4-1-5211X
1	1480/1550	1.750-10	2.500	3.547	CF 4-1-7001
1	SPL70	1.750-10	2.500	5.750	EY 70-4-161-1
1	SPL70	1.750-10	2.500	5.750	EY 70-4-171-1X
1	SPL90	1.750-10	2.500	4.125	EY 90-4-371-1
1	1480	1.750-10	2.500	5.109	EY 3-4-11561-1 <i>Flanged end yoke, strap kit not furnished by Dana</i>

Pos	Series	Spline Data	Hub Dia	* to End of Hub	End Fitting Part Number
-----	--------	-------------	---------	-----------------	-------------------------

CLARK

CL-450 (Continued)					
1	1480	1.750-10	2.500	4.000	EY 3-4-11871-1
1	1480	1.750-10	2.500	4.000	EY 3-4-11871-2 <i>Attaching hardware by OEM</i>
1	1480	1.750-10	2.500	4.000	EY 3-4-9271-1
1	1550	1.750-10	2.500	4.125	EY 4-4-4781-1
1	1550	1.750-10	2.500	4.125	EY 4-4-4781-2 <i>Attaching hardware by OEM</i>
1	1550	1.750-10	2.500	4.115	EY 4-4-6791-2 <i>Attaching hardware by OEM</i>
1	1610	1.750-10	2.500	4.125	EY 5-4-7631-1

CL-550					
1	SPL140	1.962-10	2.750	5.810	EY 140-4-181-1
1	SPL90	1.962-10	2.750	4.984	EY 90-4-381-1
1	1550	1.962-10	2.750	5.000	EY 4-4-4771-2 <i>Attaching hardware by OEM</i>
1	1550	1.750-10	2.500	4.290	EY 4-4-5251-1
1	1550	1.962-10	2.750	5.000	EY 4-4-6781-2 <i>Attaching hardware by OEM</i>
1	1610	1.962-10	2.750	5.281	EY 5-4-7041-1
1	1610	1.750-10	2.500	4.720	EY 5-4-7581-1
1	1610	1.962-10	2.750	5.281	EY 5-4-8361-1
1	1710	1.962-10	2.750	5.156	EY 6-4-3831
1	1710	1.962-10	2.750	5.156	EY 6-4-3831-1

204-V, 204-VO, 205-V, 205-VO, 207-VO, 208-V, 230-F, 231-F, 233-F, 264-V, 264-VO, 265-VO					
1	1350/1410	1.500-10	2.125	2.562	CF 3-1-1151
1	1480/1550	1.500-10	2.125	2.625	CF 4-1-2701

270-V, 270-VO					
1	1480/1550	1.750-10	2.250	2.750	CF 4-1-1381

271-T					
1	1350/1410	1.500-10	2.125	2.562	CF 3-1-1151
1	1480/1550	1.500-10	2.125	2.625	CF 4-1-2701

280-V, 282-V, 285-V, 288-V, 289-V, 290-V, 290-VO, 291-V, 303-X, 320-V, 320-VO, 325-V, 327-V, 328-V, 330-F, 330-FO, 331-F, 332-F, 333-F, 334-F					
1	1480/1550	1.750-10	2.250	2.750	CF 4-1-1381

390					
1	1550	1.962-10	2.750	5.000	EY 4-4-4771-2 <i>Attaching hardware by OEM</i>
1	1610	1.962-10	2.750	5.281	EY 5-4-7041-1

*C/L to End of Hub for EY (End Yoke); Flange Face to End of Hub for CF (Companion Flange)

■ Hub machined for speedometer gear



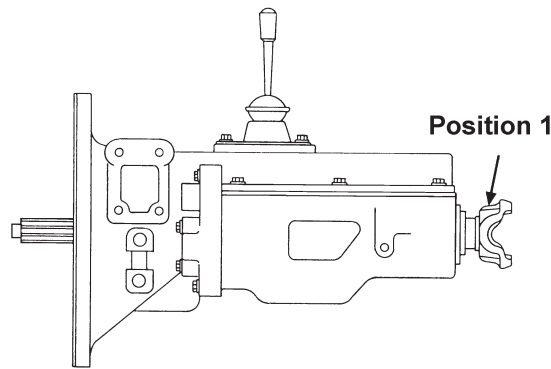

Pos	Series	Spline Data	Hub Dia	* to End of Hub	End Fitting Part Number
-----	--------	-------------	---------	-----------------	-------------------------

AR					
1	62	2.000-10	3.250	3.625	CF 5-1-931

C-2000					
1	1710	2.794-54	.000	5.625	EY 6-4-9231
1	1710	2.794-54	.000	5.625	EY 6-4-9231-1
1	1760	2.794-54	.000	5.625	EY 6.3-4-1681 <i>Hub diameter not ground</i>
1	1760	2.794-54	.000	5.625	EY 6.3-4-1681-1 <i>Hub diameter not ground</i>
1	1810	2.794-54	.000	5.625	EY 6.5-4-4631 <i>Hub diameter not ground</i>
1	1810	2.794-54	.000	5.625	EY 6.5-4-4631-1 <i>Hub diameter not ground</i>

FR-11210, FR-12210, FR-13210, FR-14210, FR-15210, FR-16210

1	SPL140	2.794-54	.000	6.320	EY 140-4-201-1
1	SPL170	2.794-54	.000	5.600	EY 170-4-561-1 <i>Hub diameter not ground</i>
1	SPL250	2.794-54	.000	5.703	EY 250-4-271-1 <i>Hub diameter not ground</i>
1	1710	2.794-54	.000	5.625	EY 6-4-9231
1	1710	2.794-54	.000	5.625	EY 6-4-9231-1
1	1760	2.794-54	.000	5.625	EY 6.3-4-1681 <i>Hub diameter not ground</i>
1	1760	2.794-54	.000	5.625	EY 6.3-4-1681-1 <i>Hub diameter not ground</i>
1	1810	2.794-54	.000	5.625	EY 6.5-4-4631 <i>Hub diameter not ground</i>
1	1810	2.794-54	.000	5.625	EY 6.5-4-4631-1 <i>Hub diameter not ground</i>

FRO-15210C

1	SPL140	2.794-54	.000	6.320	EY 140-4-201-1
1	SPL170	2.794-54	.000	5.600	EY 170-4-561-1 <i>Hub diameter not ground</i>
1	1710	2.794-54	.000	5.625	EY 6-4-9231
1	1710	2.794-54	.000	5.625	EY 6-4-9231-1
1	1760	2.794-54	.000	5.625	EY 6.3-4-1681 <i>Hub diameter not ground</i>
1	1760	2.794-54	.000	5.625	EY 6.3-4-1681-1 <i>Hub diameter not ground</i>
1	1810	2.794-54	.000	5.625	EY 6.5-4-4631 <i>Hub diameter not ground</i>
1	1810	2.794-54	.000	5.625	EY 6.5-4-4631-1 <i>Hub diameter not ground</i>

Pos	Series	Spline Data	Hub Dia	* to End of Hub	End Fitting Part Number
-----	--------	-------------	---------	-----------------	-------------------------

FRO-16210C, FRO-17210C, FRO-18210C					
1	SPL140	2.794-54	.000	6.320	EY 140-4-201-1
1	SPL170	2.794-54	.000	5.600	EY 170-4-561-1 <i>Hub diameter not ground</i>
1	SPL250	2.794-54	.000	5.703	EY 250-4-271-1 <i>Hub diameter not ground</i>
1	1710	2.794-54	.000	5.625	EY 6-4-9231
1	1710	2.794-54	.000	5.625	EY 6-4-9231-1
1	1760	2.794-54	.000	5.625	EY 6.3-4-1681 <i>Hub diameter not ground</i>
1	1760	2.794-54	.000	5.625	EY 6.3-4-1681-1 <i>Hub diameter not ground</i>
1	1810	2.794-54	.000	5.625	EY 6.5-4-4631 <i>Hub diameter not ground</i>
1	1810	2.794-54	.000	5.625	EY 6.5-4-4631-1 <i>Hub diameter not ground</i>

FS-3005, FS-3205

1	1480/1550	1.750-10	2.500	2.734	CF 4-1-5131
1	1480/1550	1.750-10	2.500	3.547	CF 4-1-5211X
1	1480/1550	1.750-10	2.500	3.547	CF 4-1-7001
1	SPL70	1.750-10	2.500	5.750	EY 70-4-161-1
1	SPL70	1.750-10	2.500	5.750	EY 70-4-171-1X
1	SPL90	1.750-10	2.500	4.125	EY 90-4-371-1
1	1480	1.750-10	2.500	5.109	EY 3-4-11561-1 <i>Flanged end yoke, strap kit not furnished by Dana</i>
1	1480	1.750-10	2.500	4.000	EY 3-4-11871-1
1	1480	1.750-10	2.500	4.000	EY 3-4-11871-2 <i>Attaching hardware by OEM</i>
1	1480	1.750-10	2.500	4.000	EY 3-4-9271-1
1	1550	1.750-10	2.500	4.125	EY 4-4-4781-1
1	1550	1.750-10	2.500	4.115	EY 4-4-6791-2 <i>Attaching hardware by OEM</i>
1	1610	1.750-10	2.500	4.125	EY 5-4-7631-1

FS-4005

1	1480/1550	1.750-10	2.500	2.734	CF 4-1-5131
1	1480/1550	1.750-10	2.500	3.547	CF 4-1-5211X
1	1480/1550	1.750-10	2.500	3.547	CF 4-1-7001
1	SPL70	1.750-10	2.500	5.750	EY 70-4-161-1
1	SPL70	1.750-10	2.500	5.750	EY 70-4-171-1X
1	SPL90	1.750-10	2.500	4.125	EY 90-4-371-1
1	1480	1.750-10	2.500	5.109	EY 3-4-11561-1 <i>Flanged end yoke, strap kit not furnished by Dana</i>
1	1480	1.750-10	2.500	4.000	EY 3-4-11871-1
1	1480	1.750-10	2.500	4.000	EY 3-4-11871-2 <i>Attaching hardware by OEM</i>

Continued on next page

*C/L to End of Hub for EY (End Yoke); Flange Face to End of Hub for CF (Companion Flange)

■ Hub machined for speedometer gear



Important: See Safety Information in General Information Section (J300P-GI)

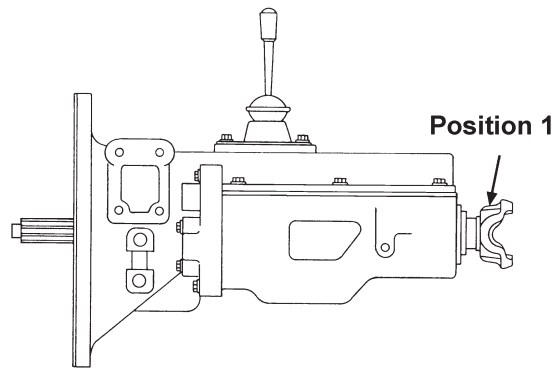

Pos	Series	Spline Data	Hub Dia	* to End of Hub	End Fitting Part Number
-----	--------	-------------	---------	-----------------	-------------------------

FS-4005 (Continued)

1	1480	1.750-10	2.500	4.000	EY 3-4-9271-1
1	1550	1.750-10	2.500	4.125	EY 4-4-4781-1
1	1550	1.750-10	2.500	4.125	EY 4-4-4781-2
					<i>Attaching hardware by OEM</i>
1	1550	1.750-10	2.500	4.115	EY 4-4-6791-2
					<i>Attaching hardware by OEM</i>
1	1610	1.750-10	2.500	4.125	EY 5-4-7631-1

FS-4205

1	1480/1550	1.750-10	2.500	2.734	CF 4-1-5131
1	1480/1550	1.750-10	2.500	3.547	CF 4-1-5211X
1	1480/1550	1.750-10	2.500	3.547	CF 4-1-7001
1	SPL55	1.750-10	2.500	5.102	EY 55-4-111-1
					<i>Flanged end yoke.</i>
1	SPL70	1.750-10	2.500	5.750	EY 70-4-161-1
1	SPL70	1.750-10	2.500	5.750	EY 70-4-171-1X
1	SPL90	1.750-10	2.500	4.125	EY 90-4-371-1
1	1480	1.750-10	2.500	5.109	EY 3-4-11561-1
					<i>Flanged end yoke, strap kit not furnished by Dana</i>
1	1480	1.750-10	2.500	4.000	EY 3-4-11871-1
1	1480	1.750-10	2.500	4.000	EY 3-4-11871-2
					<i>Attaching hardware by OEM</i>
1	1480	1.750-10	2.500	4.000	EY 3-4-9271-1
1	1550	1.750-10	2.500	4.125	EY 4-4-4781-1
1	1550	1.750-10	2.500	4.125	EY 4-4-4781-2
					<i>Attaching hardware by OEM</i>
1	1550	1.750-10	2.500	4.115	EY 4-4-6791-2
					<i>Attaching hardware by OEM</i>
1	1610	1.750-10	2.500	4.125	EY 5-4-7631-1

FS-5005

1	SPL140	1.962-10	2.750	5.810	EY 140-4-181-1
1	SPL90	1.962-10	2.750	4.984	EY 90-4-381-1
1	1550	1.962-10	2.750	5.000	EY 4-4-6781-2
					<i>Attaching hardware by OEM</i>
1	1610	1.750-10	2.500	4.720	EY 5-4-7581-1
1	1610	1.962-10	2.750	5.281	EY 5-4-8361-1
1	1710	1.962-10	2.750	5.156	EY 6-4-3831
1	1710	1.962-10	2.750	5.156	EY 6-4-3831-1

FS-5106A

1	1610	1.998-38	2.750	4.688	CF 5-1-6271
					<i>Assy includes eight 6-73-725 bolts</i>
1	1610	1.998-38	2.750	4.688	CF 5-1-6471X
					<i>Assy includes eight 6-73-725 bolts</i>
1	SPL140	1.998-38	2.750	4.830	EY 140-4-111-1
1	SPL140	1.998-38	2.750	4.830	EY 140-4-1131-1

Pos	Series	Spline Data	Hub Dia	* to End of Hub	End Fitting Part Number
-----	--------	-------------	---------	-----------------	-------------------------

FS-5106A (Continued)

1	SPL140	1.998-38	2.750	4.730	EY 140-4-891-1
1	SPL170	1.998-38	2.750	4.844	EY 170-4-541-1
1	SPL90	1.998-38	2.750	4.250	EY 90-4-391-1
1	1550	1.998-38	2.750	4.035	EY 4-4-7341-1
					<i>S/A 4-4-4491-1 Except Hub has Slinger Diameter</i>
1	1610	1.998-38	2.750	4.125	EY 5-4-6321
1	1610	1.998-38	2.750	4.000	EY 5-4-6321-1
1	1610	1.998-38	2.750	4.000	EY 5-4-8971-1
1	1710	1.998-38	2.750	5.250	EY 6-4-7301
1	1710	1.998-38	2.750	5.250	EY 6-4-7301-1

FS-5205

1	SPL140	1.962-10	2.750	5.810	EY 140-4-181-1
1	SPL90	1.962-10	2.750	4.984	EY 90-4-381-1
1	1550	1.962-10	2.750	5.000	EY 4-4-6781-2
					<i>Attaching hardware by OEM</i>
1	1610	1.962-10	2.750	5.281	EY 5-4-8361-1
1	1710	1.962-10	2.750	5.156	EY 6-4-3831
1	1710	1.962-10	2.750	5.156	EY 6-4-3831-1

FS-5306A, FS-6005, FS-6105, FS-6106

1	1610	1.998-38	2.750	4.688	CF 5-1-6271
					<i>Assy includes eight 6-73-725 bolts</i>
1	1610	1.998-38	2.750	4.688	CF 5-1-6471X
					<i>Assy includes eight 6-73-725 bolts</i>
1	SPL140	1.998-38	2.750	4.830	EY 140-4-111-1
1	SPL140	1.998-38	2.750	4.830	EY 140-4-1131-1
1	SPL140	1.998-38	2.750	4.730	EY 140-4-891-1
1	SPL170	1.998-38	2.750	4.844	EY 170-4-541-1
1	SPL90	1.998-38	2.750	4.250	EY 90-4-391-1
1	1550	1.998-38	2.750	4.035	EY 4-4-7341-1
					<i>S/A 4-4-4491-1 Except Hub has Slinger Diameter</i>
1	1610	1.998-38	2.750	4.125	EY 5-4-6321
1	1610	1.998-38	2.750	4.000	EY 5-4-6321-1
1	1610	1.998-38	2.750	4.000	EY 5-4-8971-1
1	1710	1.998-38	2.750	5.250	EY 6-4-7301
1	1710	1.998-38	2.750	5.250	EY 6-4-7301-1

FS-6205

1	1610	1.998-38	2.750	4.688	CF 5-1-6271
					<i>Assy includes eight 6-73-725 bolts</i>
1	1610	1.998-38	2.750	4.688	CF 5-1-6471X
					<i>Assy includes eight 6-73-725 bolts</i>
1	SPL170	1.998-38	2.750	4.844	EY 170-4-541-1
1	SPL90	1.998-38	2.750	4.250	EY 90-4-391-1
1	1550	1.998-38	2.750	4.035	EY 4-4-7341-1
					<i>S/A 4-4-4491-1 Except Hub has Slinger Diameter</i>

*C/L to End of Hub for EY (End Yoke); Flange Face to End of Hub for CF (Companion Flange)

■ Hub machined for speedometer gear



Pos	Series	Spline Data	Hub Dia	* to End of Hub	End Fitting Part Number
FS-6205 (Continued)					
1	1610	1.998-38	2.750	4.125	EY 5-4-6321
1	1610	1.998-38	2.750	4.000	EY 5-4-8971-1
1	1710	1.998-38	2.750	5.250	EY 6-4-7301
1	1710	1.998-38	2.750	5.250	EY 6-4-7301-1
FS-6206A					
1	1610	1.998-38	2.750	4.688	CF 5-1-6271 <i>Assy includes eight 6-73-725 bolts</i>
1	1610	1.998-38	2.750	4.688	CF 5-1-6471X <i>Assy includes eight 6-73-725 bolts</i>
1	SPL140	1.998-38	2.750	4.830	EY 140-4-111-1
1	SPL140	1.998-38	2.750	4.830	EY 140-4-1131-1
1	SPL140	1.998-38	2.750	4.730	EY 140-4-891-1
1	SPL170	1.998-38	2.750	4.844	EY 170-4-541-1
1	SPL90	1.998-38	2.750	4.250	EY 90-4-391-1
1	1550	1.998-38	2.750	4.035	EY 4-4-7341-1 <i>S/A 4-4-4491-1 Except Hub has Slinger Diameter</i>
1	1610	1.998-38	2.750	4.125	EY 5-4-6321
1	1610	1.998-38	2.750	4.000	EY 5-4-6321-1
1	1610	1.998-38	2.750	4.000	EY 5-4-8971-1
1	1710	1.998-38	2.750	5.250	EY 6-4-7301
1	1710	1.998-38	2.750	5.250	EY 6-4-7301-1
FS-6305					
1	1610	1.998-38	2.750	4.688	CF 5-1-6271 <i>Assy includes eight 6-73-725 bolts</i>
1	1610	1.998-38	2.750	4.688	CF 5-1-6471X <i>Assy includes eight 6-73-725 bolts</i>
1	SPL170	1.998-38	2.750	4.844	EY 170-4-541-1
1	SPL90	1.998-38	2.750	4.250	EY 90-4-391-1
1	1550	1.998-38	2.750	4.035	EY 4-4-7341-1 <i>S/A 4-4-4491-1 Except Hub has Slinger Diameter</i>
1	1610	1.998-38	2.750	4.125	EY 5-4-6321
1	1610	1.998-38	2.750	4.000	EY 5-4-8971-1
1	1710	1.998-38	2.750	5.250	EY 6-4-7301
1	1710	1.998-38	2.750	5.250	EY 6-4-7301-1
FS-6306A					
1	1610	1.998-38	2.750	4.688	CF 5-1-6271 <i>Assy includes eight 6-73-725 bolts</i>
1	1610	1.998-38	2.750	4.688	CF 5-1-6471X <i>Assy includes eight 6-73-725 bolts</i>
1	SPL140	1.998-38	2.750	4.830	EY 140-4-111-1
1	SPL140	1.998-38	2.750	4.730	EY 140-4-891-1
1	SPL170	1.998-38	2.750	4.844	EY 170-4-541-1
1	SPL90	1.998-38	2.750	4.250	EY 90-4-391-1
1	1550	1.998-38	2.750	4.035	EY 4-4-7341-1 <i>S/A 4-4-4491-1 Except Hub has Slinger Diameter</i>
1	1610	1.998-38	2.750	4.125	EY 5-4-6321
1	1610	1.998-38	2.750	4.000	EY 5-4-6321-1
1	1610	1.998-38	2.750	4.000	EY 5-4-8971-1
1	1710	1.998-38	2.750	5.250	EY 6-4-7301
1	1710	1.998-38	2.750	5.250	EY 6-4-7301-1
FS-7206A					
1	1610	1.998-38	2.750	4.688	CF 5-1-6271 <i>Assy includes eight 6-73-725 bolts</i>
1	1610	1.998-38	2.750	4.688	CF 5-1-6471X <i>Assy includes eight 6-73-725 bolts</i>
1	SPL140	1.998-38	2.750	4.830	EY 140-4-111-1
1	SPL140	1.998-38	2.750	4.830	EY 140-4-1131-1
1	SPL140	1.998-38	2.750	4.730	EY 140-4-891-1
1	SPL170	1.998-38	2.750	4.844	EY 170-4-541-1

Pos	Series	Spline Data	Hub Dia	* to End of Hub	End Fitting Part Number
FS-7206A (Continued)					
1	SPL90	1.998-38	2.750	4.250	EY 90-4-391-1
1	1550	1.998-38	2.750	4.035	EY 4-4-7341-1 <i>S/A 4-4-4491-1 Except Hub has Slinger Diameter</i>
1	1610	1.998-38	2.750	4.125	EY 5-4-6321
1	1610	1.998-38	2.750	4.000	EY 5-4-6321-1
1	1710	1.998-38	2.750	5.250	EY 6-4-7301
1	1710	1.998-38	2.750	5.250	EY 6-4-7301-1
FS-8109A					
1	1610	2.250-10	3.500	3.625	CF 5-1-6331
1	1810	2.250-10	3.500	3.688	CF 6.5-1-151
1	SPL140	2.250-10	3.500	6.000	EY 140-4-1091-1
1	SPL140	2.250-10	3.500	6.000	EY 140-4-1101-1X
1	SPL170	2.250-10	3.500	5.750	EY 170-4-451-1
1	SPL170	2.250-10	3.500	5.750	EY 170-4-461-1X
1	SPL90	2.250-10	3.500	5.219	EY 90-4-151-1X
1	SPL90	2.250-10	3.750	5.219	EY 90-4-161-1
1	SPL90	2.250-10	3.750	5.219	EY 90-4-171-1X
1	SPL90	2.250-10	3.500	5.219	EY 90-4-401-1
1	1550	2.250-10	3.500	5.125	EY 4-4-3501-1
1	1610	2.250-10	3.500	5.750	EY 5-4-4961
1	1610	2.250-10	3.500	5.750	EY 5-4-4961-1
1	1610	2.250-10	3.750	5.750	EY 5-4-7381-1
1	1610	2.250-10	3.750	5.750	EY 5-4-7391-1X
1	1710	2.250-10	3.500	5.250	EY 6-4-6861
1	1710	2.250-10	3.500	5.250	EY 6-4-6861-1
1	1710	2.250-10	3.500	5.250	EY 6-4-6901-1X
1	1710	2.250-10	3.750	5.250	EY 6-4-7371-1
1	1710	2.250-10	3.750	5.250	EY 6-4-7381-1X
1	1760	2.250-10	3.750	5.625	EY 6.3-4-1091-1
1	1760	2.250-10	3.750	5.625	EY 6.3-4-1101-1X
1	1810	2.250-10	3.500	5.844	EY 6.5-4-2021
FS-8206					
1	1610	2.343-45	3.750	5.750	EY 5-4-7651-1X
1	1710	2.343-45	3.750	5.250	EY 6-4-7251
1	1710	2.343-45	3.750	5.250	EY 6-4-7251-1
1	1710	2.343-45	3.750	5.250	EY 6-4-7271-1X
1	1710	2.343-45	3.750	5.250	EY 6-4-7271X
1	1760	2.343-45	3.750	5.656	EY 6.3-4-841-1
FSB-5305					
1	SPL140	1.962-10	2.750	5.810	EY 140-4-181-1
1	SPL90	1.962-10	2.750	4.984	EY 90-4-381-1
1	1550	1.962-10	2.750	5.000	EY 4-4-6781-2 <i>Attaching hardware by OEM</i>
1	1610	1.962-10	2.750	5.281	EY 5-4-8361-1
1	1710	1.962-10	2.750	5.156	EY 6-4-3831
1	1710	1.962-10	2.750	5.156	EY 6-4-3831-1
MRT-11609, MRT-11610					
1	1710	2.500-10	3.750	3.625	CF 6-1-5541
1	1710	2.500-10	3.750	3.625	CF 6-1-5651X
1	1810	2.500-10	3.750	3.625	CF 6.5-1-2271
1	1810	2.500-10	3.750	3.625	CF 6.5-1-2351X
1	SPL170	2.500-10	3.750	5.750	EY 170-4-471-1■
1	SPL170	2.500-10	3.750	5.750	EY 170-4-481-1X■
1	SPL250	2.500-10	3.750	6.062	EY 250-4-191-1■
1	SPL250	2.500-10	3.750	6.062	EY 250-4-201-1X■

Continued on next page

*C/L to End of Hub for EY (End Yoke); Flange Face to End of Hub for CF (Companion Flange)

■ Hub machined for speedometer gear



Important: See Safety Information in General Information Section (J300P-GI)

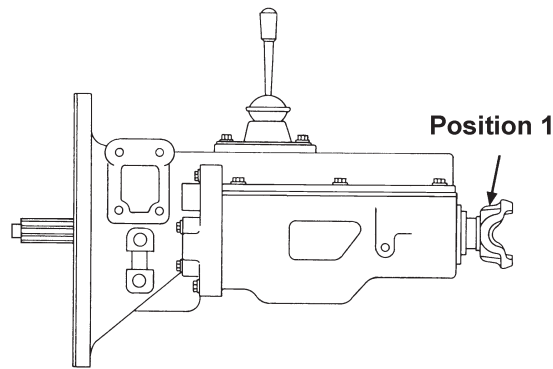

Pos	Series	Spline Data	Hub Dia	* to End of Hub	End Fitting Part Number
-----	--------	-------------	---------	-----------------	-------------------------

MRT-11609, MRT-11610 (Continued)

1	1710	2.500-10	3.750	5.625	EY 6-4-6611■
1	1710	2.500-10	3.750	5.625	EY 6-4-6611-1■
1	1710	2.500-10	3.750	5.625	EY 6-4-6921-1X■
1	1710	2.500-10	3.750	5.625	EY 6-4-6921X■
1	1760	2.500-10	3.750	6.000	EY 6.3-4-651■
1	1760	2.500-10	3.750	6.031	EY 6.3-4-651-1■
1	1760	2.500-10	3.750	6.031	EY 6.3-4-781-1X■
1	1760	2.500-10	3.750	6.000	EY 6.3-4-781X■
1	1810	2.500-10	3.750	5.875	EY 6.5-4-3451■
1	1810	2.500-10	3.750	5.875	EY 6.5-4-3451-1■
1	1810	2.500-10	3.750	5.875	EY 6.5-4-3551-1X■
1	1810	2.500-10	3.750	5.875	EY 6.5-4-3551X■

MRT-11613, MRT-11615

1	1710	2.500-10	3.750	3.625	CF 6-1-5541
1	1710	2.500-10	3.750	3.625	CF 6-1-5651X
1	1810	2.500-10	3.750	3.625	CF 6.5-1-2271
1	1810	2.500-10	3.750	3.625	CF 6.5-1-2351X
1	SPL140	2.500-10	3.750	5.960	EY 140-4-41-1
1	SPL140	2.500-10	3.750	5.960	EY 140-4-51-1X
1	SPL170	2.500-10	3.750	5.750	EY 170-4-471-1■
1	SPL170	2.500-10	3.750	5.750	EY 170-4-481-1X■
1	SPL250	2.500-10	3.750	6.062	EY 250-4-191-1■
1	SPL250	2.500-10	3.750	6.062	EY 250-4-201-1X■
1	1710	2.500-10	3.750	5.625	EY 6-4-6611■
1	1710	2.500-10	3.750	5.625	EY 6-4-6611-1■
1	1710	2.500-10	3.750	5.625	EY 6-4-6921-1X■
1	1710	2.500-10	3.750	5.625	EY 6-4-6921X■
1	1760	2.500-10	3.750	6.000	EY 6.3-4-651■
1	1760	2.500-10	3.750	6.031	EY 6.3-4-651-1■
1	1760	2.500-10	3.750	6.031	EY 6.3-4-781-1X■
1	1760	2.500-10	3.750	6.000	EY 6.3-4-781X■
1	1810	2.500-10	3.750	5.875	EY 6.5-4-3451■
1	1810	2.500-10	3.750	5.875	EY 6.5-4-3451-1■
1	1810	2.500-10	3.750	5.875	EY 6.5-4-3551-1X■
1	1810	2.500-10	3.750	5.875	EY 6.5-4-3551X■

MT-905

1	1610	2.250-10	3.500	3.625	CF 5-1-6331
1	1710	2.250-10	3.500	3.688	CF 6-1-951
1	1810	2.250-10	3.500	3.688	CF 6.5-1-151
1	SPL170	2.250-10	3.500	5.750	EY 170-4-451-1
					<i>Change seal to service older trans.</i>
1	SPL170	2.250-10	3.500	5.750	EY 170-4-461-1X
					<i>Change seal to service older trans.</i>

Pos	Series	Spline Data	Hub Dia	* to End of Hub	End Fitting Part Number
-----	--------	-------------	---------	-----------------	-------------------------

MT-905 (Continued)

1	SPL90	2.250-10	3.500	5.219	EY 90-4-151-1X
1	SPL90	2.250-10	3.750	5.219	EY 90-4-171-1X
					<i>Change seal to service older trans.</i>
1	1610	2.250-10	3.500	5.750	EY 5-4-4961
1	1610	2.250-10	3.500	5.750	EY 5-4-4961-1
1	1610	2.250-10	3.750	5.750	EY 5-4-7391-1X
1	1710	2.250-10	3.500	5.250	EY 6-4-6861
1	1710	2.250-10	3.500	5.250	EY 6-4-6861-1
1	1710	2.250-10	3.500	5.250	EY 6-4-6901-1X
1	1710	2.250-10	3.750	5.250	EY 6-4-7381-1X
					<i>Change seal to service older trans.</i>
1	1760	2.250-10	3.500	5.656	EY 6.3-4-701-1
1	1810	2.250-10	3.500	5.844	EY 6.5-4-2021
2	1610	2.250-10	3.500	3.625	CF 5-1-6331
2	1810	2.250-10	3.500	3.688	CF 6.5-1-151
2	SPL90	2.250-10	3.500	5.219	EY 90-4-151-1X
2	1610	2.250-10	3.500	5.750	EY 5-4-4961
2	1610	2.250-10	3.500	5.750	EY 5-4-4961-1
2	1610	2.250-10	3.500	5.250	EY 6-4-6861-1
2	1710	2.250-10	3.500	5.250	EY 6-4-6861
2	1810	2.250-10	3.500	5.844	EY 6.5-4-2021

MT-11605

1	1610	2.250-10	3.500	3.625	CF 5-1-6331
1	1710	2.250-10	3.500	3.688	CF 6-1-951
1	1810	2.250-10	3.500	3.688	CF 6.5-1-151
1	SPL90	2.250-10	3.500	5.219	EY 90-4-151-1X
1	SPL90	2.250-10	3.750	5.219	EY 90-4-161-1
1	SPL90	2.250-10	3.750	5.219	EY 90-4-171-1X
					<i>Change seal to service older trans.</i>
1	1610	2.250-10	3.500	5.750	EY 5-4-4961
1	1610	2.250-10	3.500	5.750	EY 5-4-4961-1
1	1610	2.250-10	3.750	5.750	EY 5-4-7381-1
1	1610	2.250-10	3.750	5.750	EY 5-4-7391-1X
1	1710	2.250-10	3.500	5.250	EY 6-4-6861
1	1710	2.250-10	3.500	5.250	EY 6-4-6861-1
1	1710	2.250-10	3.500	5.250	EY 6-4-6901-1X
1	1710	2.250-10	3.750	5.250	EY 6-4-7371-1
1	1710	2.250-10	3.750	5.250	EY 6-4-7381-1X
					<i>Change seal to service older trans.</i>
1	1760	2.250-10	3.750	5.625	EY 6.3-4-1091-1
1	1760	2.250-10	3.750	5.625	EY 6.3-4-1101-1X
					<i>Change seal to service older trans.</i>
1	1760	2.250-10	3.500	5.656	EY 6.3-4-701-1
1	1810	2.250-10	3.500	5.844	EY 6.5-4-2021

*C/L to End of Hub for EY (End Yoke); Flange Face to End of Hub for CF (Companion Flange)

■ Hub machined for speedometer gear



Pos	Series	Spline Data	Hub Dia	* to End of Hub	End Fitting Part Number
MT-11605 (Continued)					
2	1610	2.250-10	3.500	3.625	CF 5-1-6331
2	1810	2.250-10	3.500	3.688	CF 6.5-1-151
2	SPL90	2.250-10	3.500	5.219	EY 90-4-151-1X
2	SPL90	2.250-10	3.500	5.219	EY 90-4-401-1
2	1610	2.250-10	3.500	5.750	EY 5-4-4961
2	1610	2.250-10	3.500	5.750	EY 5-4-4961-1
2	1710	2.250-10	3.500	5.250	EY 6-4-6861
2	1710	2.250-10	3.500	5.250	EY 6-4-6861-1
2	1810	2.250-10	3.500	5.844	EY 6.5-4-2021
MT-9509-A					
1	1710	2.500-10	3.750	3.625	CF 6-1-5651X
1	1810	2.500-10	3.750	3.625	CF 6.5-1-2351X
1	1610	2.500-10	3.750	6.125	EY 5-4-4971■
1	1710	2.500-10	3.750	5.625	EY 6-4-6921-1X■
1	1710	2.500-10	3.750	5.625	EY 6-4-6921X■
1	1760	2.500-10	3.750	6.031	EY 6.3-4-781-1X■
1	1760	2.500-10	3.750	6.000	EY 6.3-4-781X■
1	1810	2.500-10	3.750	5.875	EY 6.5-4-3551-1X■
1	1810	2.500-10	3.750	5.875	EY 6.5-4-3551X■
R-510, R-610					
1	SPL170	2.250-10	3.500	5.750	EY 170-4-461-1X
1	SPL90	2.250-10	3.500	5.219	EY 90-4-151-1X
R-910					
1	SPL140	2.500-10	3.750	5.960	EY 140-4-51-1X
R-96T					
1	1610	2.250-10	3.500	3.625	CF 5-1-6331
1	1810	2.250-10	3.500	3.688	CF 6.5-1-151
1	SPL170	2.250-10	3.500	5.750	EY 170-4-451-1
1	SPL170	2.250-10	3.500	5.750	EY 170-4-461-1X
1	SPL90	2.250-10	3.500	5.219	EY 90-4-151-1X
1	SPL90	2.250-10	3.500	5.219	EY 90-4-401-1
1	1610	2.250-10	3.500	5.750	EY 5-4-4961
1	1610	2.250-10	3.500	5.750	EY 5-4-4961-1
1	1710	2.250-10	3.500	5.250	EY 6-4-6861
1	1710	2.250-10	3.500	5.250	EY 6-4-6861-1
1	1710	2.250-10	3.500	5.250	EY 6-4-6901-1X
1	1810	2.250-10	3.500	5.844	EY 6.5-4-2021
R-960, R-1150, R-1160					
1	1610	2.250-10	3.500	3.625	CF 5-1-6331
1	1810	2.250-10	3.500	3.688	CF 6.5-1-151
1	SPL170	2.250-10	3.500	5.750	EY 170-4-451-1
1	SPL170	2.250-10	3.500	5.750	EY 170-4-461-1X
1	SPL90	2.250-10	3.500	5.219	EY 90-4-151-1X
1	SPL90	2.250-10	3.500	5.219	EY 90-4-401-1
1	1550	2.250-10	3.500	5.125	EY 4-4-3501-1
1	1610	2.250-10	3.500	5.750	EY 5-4-4961
1	1610	2.250-10	3.500	5.750	EY 5-4-4961-1
1	1710	2.250-10	3.500	5.250	EY 6-4-6861
1	1710	2.250-10	3.500	5.250	EY 6-4-6861-1
1	1710	2.250-10	3.500	5.250	EY 6-4-6901-1X
1	1710	2.250-10	3.500	5.250	EY 6-4-6901-1X
1	1810	2.250-10	3.500	5.844	EY 6.5-4-2021
R-1550					
1	1810	2.750-10	3.750	4.062	CF 6.5-1-2311
1	1810	2.750-10	3.750	4.062	CF 6.5-1-2361X
1	SPL140	2.750-10	3.750	6.570	EY 140-4-81-1
1	SPL140	2.750-10	3.750	6.570	EY 140-4-91-1X

Pos	Series	Spline Data	Hub Dia	* to End of Hub	End Fitting Part Number
R-1550 (Continued)					
1	SPL170	2.750-10	3.750	5.850	EY 170-4-511-1
1	SPL170	2.750-10	3.750	5.850	EY 170-4-521-1X
1	SPL250	2.750-10	3.750	6.297	EY 250-4-231-1
1	SPL250	2.750-10	3.750	6.297	EY 250-4-241-1X
1	1710	2.750-10	3.750	5.750	EY 6-4-6821
1	1710	2.750-10	3.750	5.750	EY 6-4-6821-1
1	1710	2.750-10	3.750	5.750	EY 6-4-6931-1X
1	1710	2.750-10	3.750	5.750	EY 6-4-6931X
1	1760	2.750-10	3.750	5.969	EY 6.3-4-711
1	1760	2.750-10	3.750	5.969	EY 6.3-4-711-1
1	1760	2.750-10	3.750	5.969	EY 6.3-4-791-1X
1	1760	2.750-10	3.750	5.969	EY 6.3-4-791X
1	1810	2.750-10	3.750	6.062	EY 6.5-4-3491
1	1810	2.750-10	3.750	6.062	EY 6.5-4-3491-1
1	1810	2.750-10	3.750	6.062	EY 6.5-4-3561-1X
1	1810	2.750-10	3.750	6.062	EY 6.5-4-3561X
RA-96T					
1	1610	2.250-10	3.500	3.625	CF 5-1-6331
1	1710	2.250-10	3.500	3.688	CF 6-1-951
1	1810	2.250-10	3.500	3.688	CF 6.5-1-151
1	SPL90	2.250-10	3.500	5.219	EY 90-4-151-1X
1	SPL90	2.250-10	3.750	5.219	EY 90-4-171-1X
<i>Change seal to service older trans.</i>					
1	1550	2.250-10	3.500	5.125	EY 4-4-3501-1
1	1610	2.250-10	3.500	5.750	EY 5-4-4961
1	1610	2.250-10	3.500	5.750	EY 5-4-4961-1
1	1610	2.250-10	3.750	5.750	EY 5-4-7391-1X
1	1710	2.250-10	3.500	5.250	EY 6-4-6861
1	1710	2.250-10	3.500	5.250	EY 6-4-6861-1
1	1710	2.250-10	3.500	5.250	EY 6-4-6901-1X
1	1710	2.250-10	3.750	5.250	EY 6-4-7381-1X
<i>Change seal to service older trans.</i>					
1	1760	2.250-10	3.750	5.625	EY 6.3-4-1101-1X
<i>Change seal to service older trans.</i>					
1	1760	2.250-10	3.500	5.656	EY 6.3-4-701-1
1	1810	2.250-10	3.500	5.844	EY 6.5-4-2021
RA-960					
1	1610	2.250-10	3.500	3.625	CF 5-1-6331
1	1710	2.250-10	3.500	3.688	CF 6-1-951
1	1810	2.250-10	3.500	3.688	CF 6.5-1-151
1	SPL90	2.250-10	3.500	5.219	EY 90-4-151-1X
1	SPL90	2.250-10	3.750	5.219	EY 90-4-171-1X
<i>Change seal to service older trans.</i>					
1	1550	2.250-10	3.500	5.125	EY 4-4-3501-1
1	1610	2.250-10	3.500	5.750	EY 5-4-4961
1	1610	2.250-10	3.500	5.750	EY 5-4-4961-1
1	1610	2.250-10	3.750	5.750	EY 5-4-7391-1X
1	1710	2.250-10	3.500	5.250	EY 6-4-6861
1	1710	2.250-10	3.500	5.250	EY 6-4-6861-1
1	1710	2.250-10	3.500	5.250	EY 6-4-6901-1X
1	1710	2.250-10	3.750	5.250	EY 6-4-7381-1X
<i>Change seal to service older trans.</i>					
1	1760	2.250-10	3.500	5.656	EY 6.3-4-701-1
1	1810	2.250-10	3.500	5.844	EY 6.5-4-2021
RAO-11710					
1	SPL140	2.500-10	3.750	5.960	EY 140-4-51-1X

*C/L to End of Hub for EY (End Yoke); Flange Face to End of Hub for CF (Companion Flange)

■ Hub machined for speedometer gear



Important: See Safety Information in General Information Section (J300P-GI)

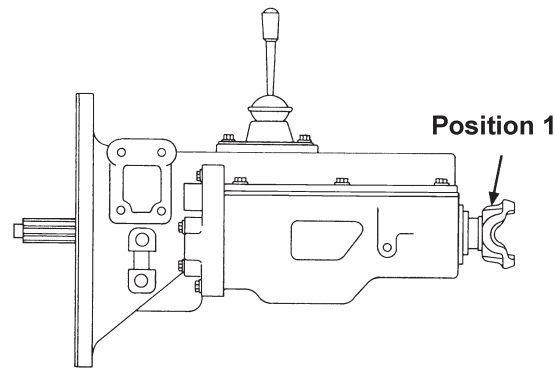

Pos	Series	Spline Data	Hub Dia	* to End of Hub	End Fitting Part Number
-----	--------	-------------	---------	-----------------	-------------------------

RT-510, RT-610

1	1610	2.250-10	3.500	3.625	CF 5-1-6331
1	1810	2.250-10	3.500	3.688	CF 6.5-1-151
1	SPL170	2.250-10	3.500	5.750	EY 170-4-451-1
1	SPL170	2.250-10	3.500	5.750	EY 170-4-461-1X
1	SPL90	2.250-10	3.500	5.219	EY 90-4-151-1X
1	SPL90	2.250-10	3.500	5.219	EY 90-4-401-1
1	1550	2.250-10	3.500	5.125	EY 4-4-3501-1
1	1610	2.250-10	3.500	5.750	EY 5-4-4961
1	1610	2.250-10	3.500	5.750	EY 5-4-4961-1
1	1710	2.250-10	3.500	5.250	EY 6-4-6861
1	1710	2.250-10	3.500	5.250	EY 6-4-6861-1
1	1710	2.250-10	3.500	5.250	EY 6-4-6901-1X
1	1810	2.250-10	3.500	5.844	EY 6.5-4-2021

RT-613, RT-906

1	1710	2.500-10	3.750	3.625	CF 6-1-5541
1	1710	2.500-10	3.750	3.625	CF 6-1-5651X
1	1810	2.500-10	3.750	3.625	CF 6.5-1-2271
1	1810	2.500-10	3.750	3.625	CF 6.5-1-2351X
1	SPL140	2.500-10	3.750	5.960	EY 140-4-41-1
1	SPL140	2.500-10	3.750	5.960	EY 140-4-51-1X
1	SPL170	2.500-10	3.750	5.750	EY 170-4-471-1■
1	SPL170	2.500-10	3.750	5.750	EY 170-4-481-1X■
1	SPL250	2.500-10	3.750	6.062	EY 250-4-191-1■
1	SPL250	2.500-10	3.750	6.062	EY 250-4-201-1X■
1	1710	2.500-10	3.750	5.625	EY 6-4-6611■
1	1710	2.500-10	3.750	5.625	EY 6-4-6611-1■
1	1710	2.500-10	3.750	5.625	EY 6-4-6921-1X■
1	1710	2.500-10	3.750	5.625	EY 6-4-6921X■
1	1760	2.500-10	3.750	6.000	EY 6.3-4-651■
1	1760	2.500-10	3.750	6.031	EY 6.3-4-651-1■
1	1760	2.500-10	3.750	6.031	EY 6.3-4-781-1X■
1	1760	2.500-10	3.750	6.000	EY 6.3-4-781X■
1	1810	2.500-10	3.750	5.875	EY 6.5-4-3451■
1	1810	2.500-10	3.750	5.875	EY 6.5-4-3451-1■
1	1810	2.500-10	3.750	5.875	EY 6.5-4-3551-1X■
1	1810	2.500-10	3.750	5.875	EY 6.5-4-3551X■

RT-909A

1	1710	2.500-10	3.750	3.625	CF 6-1-5541
1	1710	2.500-10	3.750	3.625	CF 6-1-5651X
1	1810	2.500-10	3.750	3.625	CF 6.5-1-2271
1	1810	2.500-10	3.750	3.625	CF 6.5-1-2351X
1	SPL140	2.500-10	3.750	5.960	EY 140-4-41-1
1	SPL140	2.500-10	3.750	5.960	EY 140-4-51-1X

Pos	Series	Spline Data	Hub Dia	* to End of Hub	End Fitting Part Number
-----	--------	-------------	---------	-----------------	-------------------------

RT-909A (Continued)

1	SPL170	2.500-10	3.750	5.750	EY 170-4-471-1■
1	SPL170	2.500-10	3.750	5.750	EY 170-4-481-1X■
1	SPL250	2.500-10	3.750	6.062	EY 250-4-191-1■
1	SPL250	2.500-10	3.750	6.062	EY 250-4-201-1X■
1	1710	2.500-10	3.750	5.625	EY 6-4-6611■
1	1710	2.500-10	3.750	5.625	EY 6-4-6611-1■
1	1710	2.500-10	3.750	5.625	EY 6-4-6921-1X■
1	1710	2.500-10	3.750	5.625	EY 6-4-6921X■
1	1760	2.500-10	3.750	6.000	EY 6.3-4-651■
1	1760	2.500-10	3.750	6.031	EY 6.3-4-651-1■
1	1760	2.500-10	3.750	6.031	EY 6.3-4-781-1X■
1	1760	2.500-10	3.750	6.000	EY 6.3-4-781X■
1	1810	2.225-6	3.000	6.000	EY 6.5-4-2271X
1	1810	2.500-10	3.750	5.875	EY 6.5-4-3551-1X■
1	1810	2.500-10	3.750	5.875	EY 6.5-4-3551X■
1	1860	2.500-10	3.750	5.875	EY 6.5-4-3451■
1	1860	2.500-10	3.750	5.875	EY 6.5-4-3451-1■

RT-910

1	1710	2.500-10	3.750	3.625	CF 6-1-5541
1	1710	2.500-10	3.750	3.625	CF 6-1-5651X
1	1810	2.500-10	3.750	3.625	CF 6.5-1-2271
1	1810	2.500-10	3.750	3.625	CF 6.5-1-2351X
1	SPL140	2.500-10	3.750	5.960	EY 140-4-41-1
1	SPL140	2.500-10	3.750	5.960	EY 140-4-51-1X
1	SPL170	2.500-10	3.750	5.750	EY 170-4-471-1■
1	SPL170	2.500-10	3.750	5.750	EY 170-4-481-1X■
1	SPL250	2.500-10	3.750	6.062	EY 250-4-191-1■
1	SPL250	2.500-10	3.750	6.062	EY 250-4-201-1X■
1	1710	2.500-10	3.750	5.625	EY 6-4-6611■
1	1710	2.500-10	3.750	5.625	EY 6-4-6611-1■
1	1710	2.500-10	3.750	5.625	EY 6-4-6921-1X■
1	1710	2.500-10	3.750	5.625	EY 6-4-6921X■
1	1760	2.500-10	3.750	6.000	EY 6.3-4-651■
1	1760	2.500-10	3.750	6.031	EY 6.3-4-651-1■
1	1760	2.500-10	3.750	6.031	EY 6.3-4-781-1X■
1	1760	2.500-10	3.750	6.000	EY 6.3-4-781X■
1	1810	2.500-10	3.750	5.875	EY 6.5-4-3451■
1	1810	2.500-10	3.750	5.875	EY 6.5-4-3451-1■
1	1810	2.500-10	3.750	5.875	EY 6.5-4-3551-1X■
1	1810	2.500-10	3.750	5.875	EY 6.5-4-3551X■

RT-912

1	1810	2.750-10	3.750	4.062	CF 6.5-1-2361X
1	1710	2.750-10	3.750	5.750	EY 6-4-6821

*C/L to End of Hub for EY (End Yoke); Flange Face to End of Hub for CF (Companion Flange)

■ Hub machined for speedometer gear



Pos	Series	Spline Data	Hub Dia	* to End of Hub	End Fitting Part Number
RT-912 (Continued)					
1	1710	2.750-10	3.750	5.750	EY 6-4-6821-1
1	1710	2.750-10	3.750	5.750	EY 6-4-6931-1X
1	1710	2.750-10	3.750	5.750	EY 6-4-6931X
1	1760	2.750-10	3.750	5.969	EY 6.3-4-711
1	1760	2.750-10	3.750	5.969	EY 6.3-4-711-1
1	1760	2.750-10	3.750	5.969	EY 6.3-4-791-1X
1	1760	2.750-10	3.750	5.969	EY 6.3-4-791X
1	1810	2.750-10	3.750	6.062	EY 6.5-4-3491
1	1810	2.750-10	3.750	6.062	EY 6.5-4-3491-1
1	1810	2.750-10	3.750	6.062	EY 6.5-4-3561-1X
1	1810	2.750-10	3.750	6.062	EY 6.5-4-3561X

RT-913, RT-915					
1	1710	2.500-10	3.750	3.625	CF 6-1-5541
1	1710	2.500-10	3.750	3.625	CF 6-1-5651X
1	1810	2.500-10	3.750	3.625	CF 6.5-1-2271
1	1810	2.500-10	3.750	3.625	CF 6.5-1-2351X
1	SPL140	2.500-10	3.750	5.960	EY 140-4-41-1
1	SPL140	2.500-10	3.750	5.960	EY 140-4-51-1X
1	SPL170	2.500-10	3.750	5.750	EY 170-4-471-1■
1	SPL170	2.500-10	3.750	5.750	EY 170-4-481-1X■
1	SPL250	2.500-10	3.750	6.062	EY 250-4-191-1■
1	SPL250	2.500-10	3.750	6.062	EY 250-4-201-1X■
1	1710	2.500-10	3.750	5.625	EY 6-4-6611■
1	1710	2.500-10	3.750	5.625	EY 6-4-6611-1■
1	1710	2.500-10	3.750	5.625	EY 6-4-6921-1X■
1	1710	2.500-10	3.750	5.625	EY 6-4-6921X■
1	1760	2.500-10	3.750	6.000	EY 6.3-4-651■
1	1760	2.500-10	3.750	6.031	EY 6.3-4-651-1■
1	1760	2.500-10	3.750	6.031	EY 6.3-4-781-1X■
1	1760	2.500-10	3.750	6.000	EY 6.3-4-781X■
1	1810	2.500-10	3.750	5.875	EY 6.5-4-3451■
1	1810	2.500-10	3.750	5.875	EY 6.5-4-3451-1■
1	1810	2.500-10	3.750	5.875	EY 6.5-4-3551-1X■
1	1810	2.500-10	3.750	5.875	EY 6.5-4-3551X■

RT-958LL					
1	1710	2.500-10	3.750	3.625	CF 6-1-5541
1	1710	2.500-10	3.750	3.625	CF 6-1-5651X
1	1810	2.500-10	3.750	3.625	CF 6.5-1-2271
1	1810	2.500-10	3.750	3.625	CF 6.5-1-2351X
1	SPL140	2.500-10	3.750	5.960	EY 140-4-41-1
1	SPL140	2.500-10	3.750	5.960	EY 140-4-51-1X
1	SPL170	2.500-10	3.750	5.750	EY 170-4-471-1■
1	SPL170	2.500-10	3.750	5.750	EY 170-4-481-1X■
1	SPL250	2.500-10	3.750	6.062	EY 250-4-191-1■
1	SPL250	2.500-10	3.750	6.062	EY 250-4-201-1X■
1	1610	2.500-10	3.750	6.125	EY 5-4-4971■
1	1710	2.500-10	3.750	5.625	EY 6-4-6611■
1	1710	2.500-10	3.750	5.625	EY 6-4-6611-1■
1	1710	2.500-10	3.750	5.625	EY 6-4-6921-1X■
1	1710	2.500-10	3.750	5.625	EY 6-4-6921X■
1	1760	2.500-10	3.750	6.000	EY 6.3-4-651■
1	1760	2.500-10	3.750	6.031	EY 6.3-4-651-1■
1	1760	2.500-10	3.750	6.031	EY 6.3-4-781-1X■
1	1760	2.500-10	3.750	6.000	EY 6.3-4-781X■
1	1810	2.500-10	3.750	5.875	EY 6.5-4-3451■
1	1810	2.500-10	3.750	5.875	EY 6.5-4-3451-1■
1	1810	2.500-10	3.750	5.875	EY 6.5-4-3551-1X■
1	1810	2.500-10	3.750	5.875	EY 6.5-4-3551X■

Pos	Series	Spline Data	Hub Dia	* to End of Hub	End Fitting Part Number
RT-1110					
1	1710	2.500-10	3.750	3.625	CF 6-1-5541
1	1710	2.500-10	3.750	3.625	CF 6-1-5651X
1	1810	2.500-10	3.750	3.625	CF 6.5-1-2271
1	1810	2.500-10	3.750	3.625	CF 6.5-1-2351X
1	SPL140	2.500-10	3.750	5.960	EY 140-4-41-1
1	SPL140	2.500-10	3.750	5.960	EY 140-4-51-1X
1	SPL170	2.500-10	3.750	5.750	EY 170-4-471-1■
1	SPL170	2.500-10	3.750	5.750	EY 170-4-481-1X■
1	SPL250	2.500-10	3.750	6.062	EY 250-4-191-1■
1	SPL250	2.500-10	3.750	6.062	EY 250-4-201-1X■
1	1710	2.500-10	3.750	5.625	EY 6-4-6611■
1	1710	2.500-10	3.750	5.625	EY 6-4-6611-1■
1	1710	2.500-10	3.750	5.625	EY 6-4-6921-1X■
1	1710	2.500-10	3.750	5.625	EY 6-4-6921X■
1	1760	2.500-10	3.750	6.000	EY 6.3-4-651■
1	1760	2.500-10	3.750	6.031	EY 6.3-4-651-1■
1	1760	2.500-10	3.750	6.031	EY 6.3-4-781-1X■
1	1760	2.500-10	3.750	6.000	EY 6.3-4-781X■
1	1810	2.500-10	3.750	5.875	EY 6.5-4-3451■
1	1810	2.500-10	3.750	5.875	EY 6.5-4-3451-1■
1	1810	2.500-10	3.750	5.875	EY 6.5-4-3551-1X■
1	1810	2.500-10	3.750	5.875	EY 6.5-4-3551X■

RT-1213, RT-2008					
1	1810	2.750-10	3.750	4.062	CF 6.5-1-2311
1	1810	2.750-10	3.750	4.062	CF 6.5-1-2361X
1	SPL140	2.750-10	3.750	6.570	EY 140-4-81-1
1	SPL140	2.750-10	3.750	6.570	EY 140-4-91-1X
1	SPL170	2.750-10	3.750	5.850	EY 170-4-511-1
1	SPL170	2.750-10	3.750	5.850	EY 170-4-521-1X
1	SPL250	2.750-10	3.750	6.297	EY 250-4-231-1
1	SPL250	2.750-10	3.750	6.297	EY 250-4-241-1X
1	1710	2.750-10	3.750	5.750	EY 6-4-6821
1	1710	2.750-10	3.750	5.750	EY 6-4-6821-1
1	1710	2.750-10	3.750	5.750	EY 6-4-6931-1X
1	1710	2.750-10	3.750	5.750	EY 6-4-6931X
1	1760	2.750-10	3.750	5.969	EY 6.3-4-711
1	1760	2.750-10	3.750	5.969	EY 6.3-4-711-1
1	1760	2.750-10	3.750	5.969	EY 6.3-4-791-1X
1	1760	2.750-10	3.750	5.969	EY 6.3-4-791X
1	1810	2.750-10	3.750	6.062	EY 6.5-4-3491
1	1810	2.750-10	3.750	6.062	EY 6.5-4-3491-1
1	1810	2.750-10	3.750	6.062	EY 6.5-4-3561-1X
1	1810	2.750-10	3.750	6.062	EY 6.5-4-3561X

RT-6609					
1	1610	2.250-10	3.500	3.625	CF 5-1-6331
1	1810	2.250-10	3.500	3.688	CF 6.5-1-151
1	SPL140	2.250-10	3.500	6.000	EY 140-4-1091-1
1	SPL140	2.250-10	3.500	6.000	EY 140-4-1101-1X
1	SPL170	2.250-10	3.500	5.750	EY 170-4-451-1
1	SPL170	2.250-10	3.500	5.750	EY 170-4-461-1X
1	SPL90	2.250-10	3.500	5.219	EY 90-4-151-1X
1	SPL90	2.250-10	3.750	5.219	EY 90-4-161-1
1	SPL90	2.250-10	3.750	5.219	EY 90-4-171-1X
1	SPL90	2.250-10	3.500	5.219	EY 90-4-401-1
1	1550	2.250-10	3.500	5.125	EY 4-4-3501-1
1	1610	2.250-10	3.500	5.750	EY 5-4-4961

Continued on next page

*C/L to End of Hub for EY (End Yoke); Flange Face to End of Hub for CF (Companion Flange)

■ Hub machined for speedometer gear



Important: See Safety Information in General Information Section (J300P-GI)

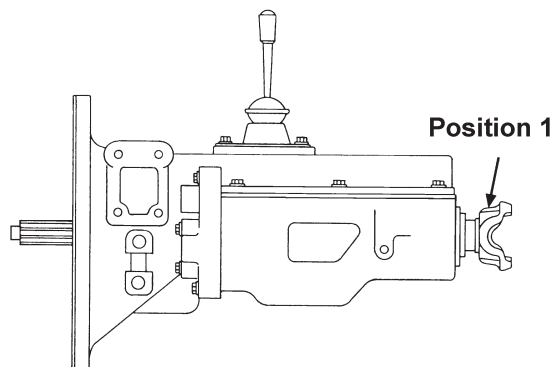

Pos	Series	Spline Data	Hub Dia	* to End of Hub	End Fitting Part Number
-----	--------	-------------	---------	-----------------	-------------------------

RT-6609 (Continued)

1	1610	2.250-10	3.500	5.750	EY 5-4-4961-1
1	1610	2.250-10	3.750	5.750	EY 5-4-7381-1
1	1610	2.250-10	3.750	5.750	EY 5-4-7391-1X
1	1710	2.250-10	3.500	5.250	EY 6-4-6861
1	1710	2.250-10	3.500	5.250	EY 6-4-6861-1
1	1710	2.250-10	3.500	5.250	EY 6-4-6901-1X
1	1710	2.250-10	3.750	5.250	EY 6-4-7371-1
1	1710	2.250-10	3.750	5.250	EY 6-4-7381-1X
1	1760	2.250-10	3.750	5.625	EY 6.3-4-1091-1
1	1760	2.250-10	3.750	5.625	EY 6.3-4-1101-1X
1	1810	2.250-10	3.500	5.844	EY 6.5-4-2021

RT-6610

1	1610	2.250-10	3.500	3.625	CF 5-1-6331
1	1810	2.250-10	3.500	3.688	CF 6.5-1-151
1	SPL140	2.250-10	3.500	6.000	EY 140-4-1091-1
1	SPL140	2.250-10	3.500	6.000	EY 140-4-1101-1X
1	SPL170	2.250-10	3.500	5.750	EY 170-4-451-1
1	SPL170	2.250-10	3.500	5.750	EY 170-4-461-1X
1	SPL90	2.250-10	3.500	5.219	EY 90-4-151-1X
1	SPL90	2.250-10	3.750	5.219	EY 90-4-161-1
1	SPL90	2.250-10	3.750	5.219	EY 90-4-171-1X
1	SPL90	2.250-10	3.500	5.219	EY 90-4-401-1
1	1550	2.250-10	3.500	5.125	EY 4-4-3501-1
1	1610	2.250-10	3.500	5.750	EY 5-4-4961
1	1610	2.250-10	3.500	5.750	EY 5-4-4961-1
1	1610	2.250-10	3.750	5.750	EY 5-4-7381-1
1	1610	2.250-10	3.750	5.750	EY 5-4-7391-1X
1	1710	2.250-10	3.500	5.250	EY 6-4-6861
1	1710	2.250-10	3.500	5.250	EY 6-4-6861-1
1	1710	2.250-10	3.500	5.250	EY 6-4-6901-1X
1	1710	2.250-10	3.750	5.250	EY 6-4-7371-1
1	1710	2.250-10	3.750	5.250	EY 6-4-7381-1X
1	1760	2.250-10	3.750	5.625	EY 6.3-4-1091-1
1	1760	2.250-10	3.750	5.625	EY 6.3-4-1101-1X
1	1760	2.250-10	3.500	5.656	EY 6.3-4-701-1
1	1810	2.250-10	3.500	5.844	EY 6.5-4-2021

RT-6613

1	1710	2.500-10	3.750	3.625	CF 6-1-5541
1	1710	2.500-10	3.750	3.625	CF 6-1-5651X
1	1810	2.500-10	3.750	3.625	CF 6.5-1-2271
1	1810	2.500-10	3.750	3.625	CF 6.5-1-2351X
1	SPL140	2.500-10	3.750	5.960	EY 140-4-1111-1
1	SPL140	2.500-10	3.750	5.960	EY 140-4-1121-1X

Pos	Series	Spline Data	Hub Dia	* to End of Hub	End Fitting Part Number
-----	--------	-------------	---------	-----------------	-------------------------

RT-6613 (Continued)

1	SPL140	2.500-10	3.750	5.960	EY 140-4-41-1
1	SPL140	2.500-10	3.750	5.960	EY 140-4-51-1X
1	SPL170	2.500-10	3.750	5.750	EY 170-4-471-1■
1	SPL170	2.500-10	3.750	5.750	EY 170-4-481-1X■
1	SPL250	2.500-10	3.750	6.062	EY 250-4-191-1■
1	SPL250	2.500-10	3.750	6.062	EY 250-4-201-1X■
1	1710	2.500-10	3.750	5.625	EY 6-4-6611■
1	1710	2.500-10	3.750	5.625	EY 6-4-6611-1■
1	1710	2.500-10	3.750	5.625	EY 6-4-6921-1X■
1	1710	2.500-10	3.750	5.625	EY 6-4-6921X■
1	1760	2.500-10	3.750	6.000	EY 6.3-4-651■
1	1760	2.500-10	3.750	6.031	EY 6.3-4-651-1■
1	1760	2.500-10	3.750	6.031	EY 6.3-4-781-1X■
1	1760	2.500-10	3.750	6.000	EY 6.3-4-781X■
1	1810	2.500-10	3.750	5.875	EY 6.5-4-3451■
1	1810	2.500-10	3.750	5.875	EY 6.5-4-3451-1■
1	1810	2.500-10	3.750	5.875	EY 6.5-4-3551-1X■
1	1810	2.500-10	3.750	5.875	EY 6.5-4-3551X■

RT-7608LL, RT-8608LL

1	1710	2.500-10	3.750	3.625	CF 6-1-5541
1	1710	2.500-10	3.750	3.625	CF 6-1-5651X
1	1810	2.500-10	3.750	3.625	CF 6.5-1-2271
1	1810	2.500-10	3.750	3.625	CF 6.5-1-2351X
1	SPL140	2.500-10	3.750	5.960	EY 140-4-41-1
1	SPL140	2.500-10	3.750	5.960	EY 140-4-51-1X
1	SPL170	2.500-10	3.750	5.750	EY 170-4-471-1■
1	SPL170	2.500-10	3.750	5.750	EY 170-4-481-1X■
1	SPL250	2.500-10	3.750	6.062	EY 250-4-191-1■
1	SPL250	2.500-10	3.750	6.062	EY 250-4-201-1X■
1	1710	2.500-10	3.750	5.625	EY 6-4-6611■
1	1710	2.500-10	3.750	5.625	EY 6-4-6611-1■
1	1710	2.500-10	3.750	5.625	EY 6-4-6921-1X■
1	1710	2.500-10	3.750	5.625	EY 6-4-6921X■
1	1760	2.500-10	3.750	6.000	EY 6.3-4-651■
1	1760	2.500-10	3.750	6.031	EY 6.3-4-651-1■
1	1760	2.500-10	3.750	6.031	EY 6.3-4-781-1X■
1	1760	2.500-10	3.750	6.000	EY 6.3-4-781X■
1	1810	2.500-10	3.750	5.875	EY 6.5-4-3451■
1	1810	2.500-10	3.750	5.875	EY 6.5-4-3451-1■
1	1810	2.500-10	3.750	5.875	EY 6.5-4-3551-1X■
1	1810	2.500-10	3.750	5.875	EY 6.5-4-3551X■

*C/L to End of Hub for EY (End Yoke); Flange Face to End of Hub for CF (Companion Flange)

■ Hub machined for speedometer gear



Pos	Series	Spline Data	Hub Dia	* to End of Hub	End Fitting Part Number
RT-8609					
1	1610	2.250-10	3.500	3.625	CF 5-1-6331
1	1810	2.250-10	3.500	3.688	CF 6.5-1-151
1	SPL170	2.250-10	3.500	5.750	EY 170-4-451-1
1	SPL170	2.250-10	3.500	5.750	EY 170-4-461-1X
1	SPL90	2.250-10	3.500	5.219	EY 90-4-151-1X
1	SPL90	2.250-10	3.750	5.219	EY 90-4-161-1
1	SPL90	2.250-10	3.750	5.219	EY 90-4-171-1X
1	SPL90	2.250-10	3.500	5.219	EY 90-4-401-1
1	1550	2.250-10	3.500	5.125	EY 4-4-3501-1
1	1610	2.250-10	3.500	5.750	EY 5-4-4961
1	1610	2.250-10	3.500	5.750	EY 5-4-4961-1
1	1610	2.250-10	3.750	5.750	EY 5-4-7381-1
1	1610	2.250-10	3.750	5.750	EY 5-4-7391-1X
1	1710	2.250-10	3.500	5.250	EY 6-4-6861
1	1710	2.250-10	3.500	5.250	EY 6-4-6861-1
1	1710	2.250-10	3.500	5.250	EY 6-4-6901-1X
1	1710	2.250-10	3.750	5.250	EY 6-4-7371-1
1	1710	2.250-10	3.750	5.250	EY 6-4-7381-1X
1	1760	2.250-10	3.750	5.625	EY 6.3-4-1091-1
1	1760	2.250-10	3.750	5.625	EY 6.3-4-1101-1X
1	1760	2.250-10	3.500	5.656	EY 6.3-4-701-1
1	1810	2.250-10	3.500	5.844	EY 6.5-4-2021

RT-8709					
1	1710	2.500-10	3.750	3.625	CF 6-1-5541
1	1710	2.500-10	3.750	3.625	CF 6-1-5651X
1	1810	2.500-10	3.750	3.625	CF 6.5-1-2271
1	1810	2.500-10	3.750	3.625	CF 6.5-1-2351X
1	SPL140	2.500-10	3.750	5.960	EY 140-4-41-1
1	SPL140	2.500-10	3.750	5.960	EY 140-4-51-1X
1	SPL170	2.500-10	3.750	5.750	EY 170-4-471-1■
1	SPL170	2.500-10	3.750	5.750	EY 170-4-481-1X■
1	SPL250	2.500-10	3.750	6.062	EY 250-4-191-1■
1	SPL250	2.500-10	3.750	6.062	EY 250-4-201-1X■
1	1710	2.500-10	3.750	5.625	EY 6-4-6611■
1	1710	2.500-10	3.750	5.625	EY 6-4-6611-1■
1	1710	2.500-10	3.750	5.625	EY 6-4-6921-1X■
1	1710	2.500-10	3.750	5.625	EY 6-4-6921X■
1	1760	2.500-10	3.750	6.000	EY 6.3-4-651■
1	1760	2.500-10	3.750	6.031	EY 6.3-4-651-1■
1	1760	2.500-10	3.750	6.031	EY 6.3-4-781-1X■
1	1760	2.500-10	3.750	6.000	EY 6.3-4-781X■
1	1810	2.500-10	3.750	5.875	EY 6.5-4-3451■
1	1810	2.500-10	3.750	5.875	EY 6.5-4-3451-1■
1	1810	2.500-10	3.750	5.875	EY 6.5-4-3551-1X■
1	1810	2.500-10	3.750	5.875	EY 6.5-4-3551X■

RT-8908					
1	1710	2.794-54	.000	5.625	EY 6-4-9231
1	1710	2.794-54	.000	5.625	EY 6-4-9231-1
1	1760	2.794-54	.000	5.625	EY 6.3-4-1681
					<i>Hub diameter not ground</i>
1	1760	2.794-54	.000	5.625	EY 6.3-4-1681-1
					<i>Hub diameter not ground</i>
1	1810	2.794-54	.000	5.625	EY 6.5-4-4631
					<i>Hub diameter not ground</i>
1	1810	2.794-54	.000	5.625	EY 6.5-4-4631-1
					<i>Hub diameter not ground</i>

Pos	Series	Spline Data	Hub Dia	* to End of Hub	End Fitting Part Number
RT-8908LL					
1	1810	2.794-54	.000	5.625	EY 6.5-4-4631
					<i>Hub diameter not ground</i>

RT-8909LL					
1	1710	2.794-54	.000	5.625	EY 6-4-9231
1	1710	2.794-54	.000	5.625	EY 6-4-9231-1
1	1760	2.794-54	.000	5.625	EY 6.3-4-1681
					<i>Hub diameter not ground</i>
1	1760	2.794-54	.000	5.625	EY 6.3-4-1681-1
					<i>Hub diameter not ground</i>
1	1810	2.794-54	.000	5.625	EY 6.5-4-4631
					<i>Hub diameter not ground</i>
1	1810	2.794-54	.000	5.625	EY 6.5-4-4631-1
					<i>Hub diameter not ground</i>

RT-9109					
1	1710	2.500-10	3.750	3.625	CF 6-1-5541
1	1710	2.500-10	3.750	3.625	CF 6-1-5651X
1	1810	2.500-10	3.750	3.625	CF 6.5-1-2271
1	1810	2.500-10	3.750	3.625	CF 6.5-1-2351X
1	SPL140	2.500-10	3.750	5.960	EY 140-4-41-1
1	SPL140	2.500-10	3.750	5.960	EY 140-4-51-1X
1	SPL170	2.500-10	3.750	5.750	EY 170-4-471-1■
1	SPL170	2.500-10	3.750	5.750	EY 170-4-481-1X■
1	SPL250	2.500-10	3.750	6.062	EY 250-4-191-1■
1	SPL250	2.500-10	3.750	6.062	EY 250-4-201-1X■
1	1710	2.500-10	3.750	5.625	EY 6-4-6611■
1	1710	2.500-10	3.750	5.625	EY 6-4-6611-1■
1	1710	2.500-10	3.750	5.625	EY 6-4-6921-1X■
1	1710	2.500-10	3.750	5.625	EY 6-4-6921X■
1	1760	2.500-10	3.750	6.000	EY 6.3-4-651■
1	1760	2.500-10	3.750	6.031	EY 6.3-4-651-1■
1	1760	2.500-10	3.750	6.031	EY 6.3-4-781-1X■
1	1760	2.500-10	3.750	6.000	EY 6.3-4-781X■
1	1810	2.500-10	3.750	5.875	EY 6.5-4-3451■
1	1810	2.500-10	3.750	5.875	EY 6.5-4-3451-1■
1	1810	2.500-10	3.750	5.875	EY 6.5-4-3551-1X■
1	1810	2.500-10	3.750	5.875	EY 6.5-4-3551X■

RT-9508					
1	1650/1710	2.500-10	3.750	3.625	CF 6-1-5541
1	1650/1710	2.500-10	3.750	3.625	CF 6-1-5651X
1	1810	2.500-10	3.750	3.625	CF 6.5-1-2351X
1	SPL140	2.500-10	3.750	5.960	EY 140-4-41-1
1	SPL140	2.500-10	3.750	5.960	EY 140-4-51-1X
1	SPL170	2.500-10	3.750	5.750	EY 170-4-471-1■
1	SPL170	2.500-10	3.750	5.750	EY 170-4-481-1X■
1	SPL250	2.500-10	3.750	6.062	EY 250-4-191-1■
1	SPL250	2.500-10	3.750	6.062	EY 250-4-201-1X■
1	1710	2.500-10	3.750	5.625	EY 6-4-6611■
1	1710	2.500-10	3.750	5.625	EY 6-4-6611-1■
1	1710	2.500-10	3.750	5.625	EY 6-4-6921-1X■
1	1710	2.500-10	3.750	5.625	EY 6-4-6921X■
1	1760	2.500-10	3.750	6.000	EY 6.3-4-651■
1	1760	2.500-10	3.750	6.031	EY 6.3-4-651-1■
1	1760	2.500-10	3.750	6.031	EY 6.3-4-781-1X■
1	1760	2.500-10	3.750	6.000	EY 6.3-4-781X■
1	1810	2.500-10	3.750	5.875	EY 6.5-4-3451■
1	1810	2.500-10	3.750	5.875	EY 6.5-4-3451-1■
1	1810	2.500-10	3.750	5.875	EY 6.5-4-3551-1X■
1	1810	2.500-10	3.750	5.875	EY 6.5-4-3551X■

*C/L to End of Hub for EY (End Yoke); Flange Face to End of Hub for CF (Companion Flange)

■ Hub machined for speedometer gear



Important: See Safety Information in General Information Section (J300P-GI)

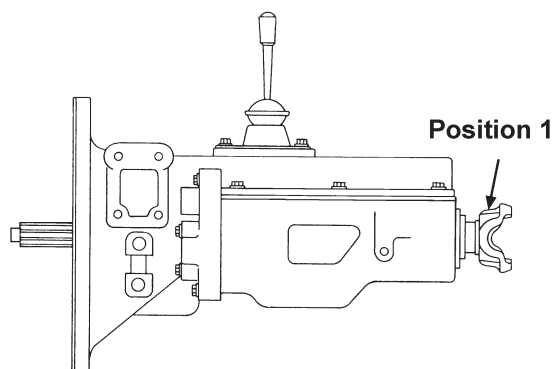

Pos	Series	Spline Data	Hub Dia	* to End of Hub	End Fitting Part Number
-----	--------	-------------	---------	-----------------	-------------------------

RT-9509A, RT-9509B, RT-9513

1	1710	2.500-10	3.750	3.625	CF 6-1-5541
1	1710	2.500-10	3.750	3.625	CF 6-1-5651X
1	1810	2.500-10	3.750	3.625	CF 6.5-1-2271
1	1810	2.500-10	3.750	3.625	CF 6.5-1-2351X
1	SPL140	2.500-10	3.750	5.960	EY 140-4-41-1
1	SPL140	2.500-10	3.750	5.960	EY 140-4-51-1X
1	SPL170	2.500-10	3.750	5.750	EY 170-4-471-1■
1	SPL170	2.500-10	3.750	5.750	EY 170-4-481-1X■
1	SPL250	2.500-10	3.750	6.062	EY 250-4-191-1■
1	SPL250	2.500-10	3.750	6.062	EY 250-4-201-1X■
1	1710	2.500-10	3.750	5.625	EY 6-4-6611■
1	1710	2.500-10	3.750	5.625	EY 6-4-6611-1■
1	1710	2.500-10	3.750	5.625	EY 6-4-6921-1X■
1	1710	2.500-10	3.750	5.625	EY 6-4-6921X■
1	1760	2.500-10	3.750	6.000	EY 6.3-4-651■
1	1760	2.500-10	3.750	6.031	EY 6.3-4-651-1■
1	1760	2.500-10	3.750	6.031	EY 6.3-4-781-1X■
1	1760	2.500-10	3.750	6.000	EY 6.3-4-781X■
1	1810	2.500-10	3.750	5.875	EY 6.5-4-3451■
1	1810	2.500-10	3.750	5.875	EY 6.5-4-3451-1■
1	1810	2.500-10	3.750	5.875	EY 6.5-4-3551-1X■
1	1810	2.500-10	3.750	5.875	EY 6.5-4-3551X■

RT-11109

1	1810	2.750-10	3.750	4.062	CF 6.5-1-2311
1	1810	2.750-10	3.750	4.062	CF 6.5-1-2361X
1	SPL140	2.750-10	3.750	6.570	EY 140-4-81-1
1	SPL140	2.750-10	3.750	6.570	EY 140-4-91-1X
1	SPL170	2.750-10	3.750	5.850	EY 170-4-521-1X
1	1710	2.750-10	3.750	5.750	EY 6-4-6821
1	1710	2.750-10	3.750	5.750	EY 6-4-6821-1
1	1710	2.750-10	3.750	5.750	EY 6-4-6931-1X
1	1710	2.750-10	3.750	5.750	EY 6-4-6931X
1	1760	2.750-10	3.750	5.969	EY 6.3-4-711
1	1760	2.750-10	3.750	5.969	EY 6.3-4-711-1
1	1760	2.750-10	3.750	5.969	EY 6.3-4-791-1X
1	1760	2.750-10	3.750	5.969	EY 6.3-4-791X
1	1810	2.750-10	3.750	6.062	EY 6.5-4-3491
1	1810	2.750-10	3.750	6.062	EY 6.5-4-3491-1X
1	1810	2.750-10	3.750	6.062	EY 6.5-4-3561-1X
1	1810	2.750-10	3.750	6.062	EY 6.5-4-3561X

RT-11509

1	1710	2.500-10	3.750	3.625	CF 6-1-5541
1	1710	2.500-10	3.750	3.625	CF 6-1-5651X

Pos	Series	Spline Data	Hub Dia	* to End of Hub	End Fitting Part Number
-----	--------	-------------	---------	-----------------	-------------------------

RT-11509 (Continued)

1	1810	2.500-10	3.750	3.625	CF 6.5-1-2271
1	1810	2.500-10	3.750	3.625	CF 6.5-1-2351X
1	SPL140	2.500-10	3.750	5.960	EY 140-4-41-1
1	SPL140	2.500-10	3.750	5.960	EY 140-4-51-1X
1	SPL170	2.500-10	3.750	5.750	EY 170-4-471-1■
1	SPL170	2.500-10	3.750	5.750	EY 170-4-481-1X■
1	SPL250	2.500-10	3.750	6.062	EY 250-4-191-1■
1	SPL250	2.500-10	3.750	6.062	EY 250-4-201-1X■
1	1710	2.500-10	3.750	5.625	EY 6-4-6611■
1	1710	2.500-10	3.750	5.625	EY 6-4-6611-1■
1	1710	2.500-10	3.750	5.625	EY 6-4-6921-1X■
1	1710	2.500-10	3.750	5.625	EY 6-4-6921X■
1	1760	2.500-10	3.750	6.000	EY 6.3-4-651■
1	1760	2.500-10	3.750	6.031	EY 6.3-4-651-1■
1	1760	2.500-10	3.750	6.031	EY 6.3-4-781-1X■
1	1760	2.500-10	3.750	6.000	EY 6.3-4-781X■
1	1810	2.500-10	3.750	5.875	EY 6.5-4-3451■
1	1810	2.500-10	3.750	5.875	EY 6.5-4-3451-1■
1	1810	2.500-10	3.750	5.875	EY 6.5-4-3551-1X■
1	1810	2.500-10	3.750	5.875	EY 6.5-4-3551X■

RT-11608

1	1710	2.500-10	3.750	3.625	CF 6-1-5541
1	1710	2.500-10	3.750	3.625	CF 6-1-5651X
1	1810	2.500-10	3.750	3.625	CF 6.5-1-2271
1	1810	2.500-10	3.750	3.625	CF 6.5-1-2351X
1	SPL140	2.500-10	3.750	5.960	EY 140-4-1111-1
1	SPL140	2.500-10	3.750	5.960	EY 140-4-1121-1X
1	SPL140	2.500-10	3.750	5.960	EY 140-4-41-1
1	SPL140	2.500-10	3.750	5.960	EY 140-4-51-1X
1	SPL170	2.500-10	3.750	5.750	EY 170-4-471-1■
1	SPL170	2.500-10	3.750	5.750	EY 170-4-481-1X■
1	SPL250	2.500-10	3.750	6.062	EY 250-4-191-1■
1	SPL250	2.500-10	3.750	6.062	EY 250-4-201-1X■
1	1710	2.500-10	3.750	5.625	EY 6-4-6611■
1	1710	2.500-10	3.750	5.625	EY 6-4-6611-1■
1	1710	2.500-10	3.750	5.625	EY 6-4-6921-1X■
1	1710	2.500-10	3.750	5.625	EY 6-4-6921X■
1	1760	2.500-10	3.750	6.000	EY 6.3-4-651■
1	1760	2.500-10	3.750	6.031	EY 6.3-4-651-1■
1	1760	2.500-10	3.750	6.031	EY 6.3-4-781-1X■
1	1760	2.500-10	3.750	6.000	EY 6.3-4-781X■
1	1810	2.500-10	3.750	5.875	EY 6.5-4-3451■
1	1810	2.500-10	3.750	5.875	EY 6.5-4-3451-1■
1	1810	2.500-10	3.750	5.875	EY 6.5-4-3551-1X■
1	1810	2.500-10	3.750	5.875	EY 6.5-4-3551X■

*C/L to End of Hub for EY (End Yoke); Flange Face to End of Hub for CF (Companion Flange)

■ Hub machined for speedometer gear



Pos	Series	Spline Data	Hub Dia	* to End of Hub	End Fitting Part Number
RT-11609, RT-11609A					
1	1710	2.500-10	3.750	3.625	CF 6-1-5541
1	1710	2.500-10	3.750	3.625	CF 6-1-5651X
1	1810	2.500-10	3.750	3.625	CF 6.5-1-2271
1	1810	2.500-10	3.750	3.625	CF 6.5-1-2351X
1	SPL140	2.500-10	3.750	5.960	EY 140-4-41-1
1	SPL140	2.500-10	3.750	5.960	EY 140-4-51-1X
1	SPL170	2.500-10	3.750	5.750	EY 170-4-471-1■
1	SPL170	2.500-10	3.750	5.750	EY 170-4-481-1X■
1	SPL250	2.500-10	3.750	6.062	EY 250-4-191-1■
1	SPL250	2.500-10	3.750	6.062	EY 250-4-201-1X■
1	1710	2.500-10	3.750	5.625	EY 6-4-6611■
1	1710	2.500-10	3.750	5.625	EY 6-4-6611-1■
1	1710	2.500-10	3.750	5.625	EY 6-4-6921-1X■
1	1710	2.500-10	3.750	5.625	EY 6-4-6921X■
1	1760	2.500-10	3.750	6.000	EY 6.3-4-651■
1	1760	2.500-10	3.750	6.031	EY 6.3-4-651-1■
1	1760	2.500-10	3.750	6.031	EY 6.3-4-781-1X■
1	1760	2.500-10	3.750	6.000	EY 6.3-4-781X■
1	1810	2.500-10	3.750	5.875	EY 6.5-4-3451■
1	1810	2.500-10	3.750	5.875	EY 6.5-4-3451-1■
1	1810	2.500-10	3.750	5.875	EY 6.5-4-3551-1X■
1	1810	2.500-10	3.750	5.875	EY 6.5-4-3551X■
RT-11610, RT-11613					
1	1710	2.500-10	3.750	3.625	CF 6-1-5541
1	1710	2.500-10	3.750	3.625	CF 6-1-5651X
1	1810	2.500-10	3.750	3.625	CF 6.5-1-2271
1	1810	2.500-10	3.750	3.625	CF 6.5-1-2351X
1	SPL140	2.500-10	3.750	5.960	EY 140-4-1111-1
1	SPL140	2.500-10	3.750	5.960	EY 140-4-1121-1X
1	SPL140	2.500-10	3.750	5.960	EY 140-4-41-1
1	SPL140	2.500-10	3.750	5.960	EY 140-4-51-1X
1	SPL170	2.500-10	3.750	5.750	EY 170-4-471-1■
1	SPL170	2.500-10	3.750	5.750	EY 170-4-481-1X■
1	SPL250	2.500-10	3.750	6.062	EY 250-4-191-1■
1	SPL250	2.500-10	3.750	6.062	EY 250-4-201-1X■
1	1710	2.500-10	3.750	5.625	EY 6-4-6611■
1	1710	2.500-10	3.750	5.625	EY 6-4-6611-1■
1	1710	2.500-10	3.750	5.625	EY 6-4-6921-1X■
1	1710	2.500-10	3.750	5.625	EY 6-4-6921X■
1	1760	2.500-10	3.750	6.000	EY 6.3-4-651■
1	1760	2.500-10	3.750	6.031	EY 6.3-4-651-1■
1	1760	2.500-10	3.750	6.031	EY 6.3-4-781-1X■
1	1760	2.500-10	3.750	6.000	EY 6.3-4-781X■
1	1810	2.500-10	3.750	5.875	EY 6.5-4-3451■
1	1810	2.500-10	3.750	5.875	EY 6.5-4-3451-1■
1	1810	2.500-10	3.750	5.875	EY 6.5-4-3551-1X■
1	1810	2.500-10	3.750	5.875	EY 6.5-4-3551X■
RT-11615					
1	1710	2.500-10	3.750	3.625	CF 6-1-5541
1	1710	2.500-10	3.750	3.625	CF 6-1-5651X
1	1810	2.500-10	3.750	3.625	CF 6.5-1-2271
1	1810	2.500-10	3.750	3.625	CF 6.5-1-2351X
1	SPL140	2.500-10	3.750	5.960	EY 140-4-41-1
1	SPL140	2.500-10	3.750	5.960	EY 140-4-51-1X
1	SPL170	2.500-10	3.750	5.750	EY 170-4-471-1■
1	SPL170	2.500-10	3.750	5.750	EY 170-4-481-1X■
1	SPL250	2.500-10	3.750	6.062	EY 250-4-191-1■
1	SPL250	2.500-10	3.750	6.062	EY 250-4-201-1X■

Pos	Series	Spline Data	Hub Dia	* to End of Hub	End Fitting Part Number
RT-11615 (Continued)					
1	1710	2.500-10	3.750	5.625	EY 6-4-6611■
1	1710	2.500-10	3.750	5.625	EY 6-4-6611-1■
1	1710	2.500-10	3.750	5.625	EY 6-4-6921-1X■
1	1710	2.500-10	3.750	5.625	EY 6-4-6921X■
1	1760	2.500-10	3.750	6.000	EY 6.3-4-651■
1	1760	2.500-10	3.750	6.031	EY 6.3-4-651-1■
1	1760	2.500-10	3.750	6.031	EY 6.3-4-781-1X■
1	1760	2.500-10	3.750	6.000	EY 6.3-4-781X■
1	1810	2.500-10	3.750	5.875	EY 6.5-4-3451■
1	1810	2.500-10	3.750	5.875	EY 6.5-4-3451-1■
1	1810	2.500-10	3.750	5.875	EY 6.5-4-3551-1X■
1	1810	2.500-10	3.750	5.875	EY 6.5-4-3551X■
RT-11618					
1	1710	2.500-10	3.750	3.625	CF 6-1-5541
1	1710	2.500-10	3.750	3.625	CF 6-1-5651X
1	1810	2.500-10	3.750	3.625	CF 6.5-1-2271
1	1810	2.500-10	3.750	3.625	CF 6.5-1-2351X
1	SPL140	2.500-10	3.750	5.960	EY 140-4-41-1
1	SPL140	2.500-10	3.750	5.960	EY 140-4-51-1X
1	SPL170	2.500-10	3.750	5.750	EY 170-4-471-1■
1	SPL170	2.500-10	3.750	5.750	EY 170-4-481-1X■
1	SPL250	2.500-10	3.750	6.062	EY 250-4-191-1■
1	SPL250	2.500-10	3.750	6.062	EY 250-4-201-1X■
1	1610	2.500-10	3.750	6.125	EY 5-4-4971■
1	1710	2.500-10	3.750	5.625	EY 6-4-6611■
1	1710	2.500-10	3.750	5.625	EY 6-4-6611-1■
1	1710	2.500-10	3.750	5.625	EY 6-4-6921-1X■
1	1710	2.500-10	3.750	5.625	EY 6-4-6921X■
1	1760	2.500-10	3.750	6.000	EY 6.3-4-651■
1	1760	2.500-10	3.750	6.031	EY 6.3-4-651-1■
1	1760	2.500-10	3.750	6.031	EY 6.3-4-781-1X■
1	1760	2.500-10	3.750	6.000	EY 6.3-4-781X■
1	1810	2.500-10	3.750	5.875	EY 6.5-4-3451■
1	1810	2.500-10	3.750	5.875	EY 6.5-4-3451-1■
1	1810	2.500-10	3.750	5.875	EY 6.5-4-3551-1X■
1	1810	2.500-10	3.750	5.875	EY 6.5-4-3551X■
RT-11709, RT-11710, RT-11715					
1	1710	2.500-10	3.750	3.625	CF 6-1-5541
1	1710	2.500-10	3.750	3.625	CF 6-1-5651X
1	1810	2.500-10	3.750	3.625	CF 6.5-1-2271
1	1810	2.500-10	3.750	3.625	CF 6.5-1-2351X
1	SPL140	2.500-10	3.750	5.960	EY 140-4-1111-1
1	SPL140	2.500-10	3.750	5.960	EY 140-4-1121-1X
1	SPL140	2.500-10	3.750	5.960	EY 140-4-41-1
1	SPL140	2.500-10	3.750	5.960	EY 140-4-51-1X
1	SPL170	2.500-10	3.750	5.750	EY 170-4-471-1■
1	SPL170	2.500-10	3.750	5.750	EY 170-4-481-1X■
1	SPL250	2.500-10	3.750	6.062	EY 250-4-191-1■
1	SPL250	2.500-10	3.750	6.062	EY 250-4-201-1X■
1	1710	2.500-10	3.750	5.625	EY 6-4-6611■
1	1710	2.500-10	3.750	5.625	EY 6-4-6611-1■
1	1710	2.500-10	3.750	5.625	EY 6-4-6921-1X■
1	1710	2.500-10	3.750	5.625	EY 6-4-6921X■
1	1760	2.500-10	3.750	6.000	EY 6.3-4-651■
1	1760	2.500-10	3.750	6.031	EY 6.3-4-651-1■
1	1760	2.500-10	3.750	6.031	EY 6.3-4-781-1X■
1	1760	2.500-10	3.750	6.000	EY 6.3-4-781X■
1	1810	2.500-10	3.750	5.875	EY 6.5-4-3451■
1	1810	2.500-10	3.750	5.875	EY 6.5-4-3451-1■
1	1810	2.500-10	3.750	5.875	EY 6.5-4-3551-1X■
1	1810	2.500-10	3.750	5.875	EY 6.5-4-3551X■

*C/L to End of Hub for EY (End Yoke); Flange Face to End of Hub for CF (Companion Flange)

■ Hub machined for speedometer gear



Important: See Safety Information in General Information Section (J300P-GI)

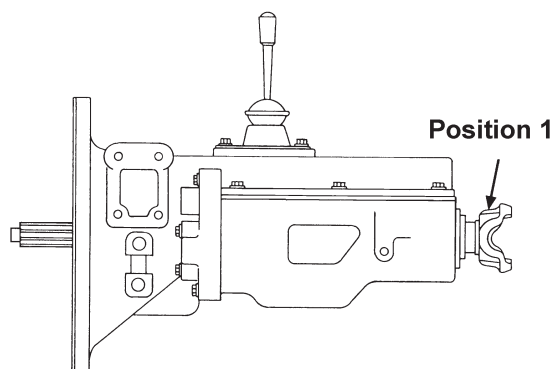

Pos	Series	Spline Data	Hub Dia	* to End of Hub	End Fitting Part Number
RT-11908LL					
1	1710	2.794-54	.000	5.625	EY 6-4-9231
1	1710	2.794-54	.000	5.625	EY 6-4-9231-1
1	1760	2.794-54	.000	5.625	EY 6.3-4-1681 <i>Hub diameter not ground</i>
1	1760	2.794-54	.000	5.625	EY 6.3-4-1681-1 <i>Hub diameter not ground</i>
1	1810	2.794-54	.000	5.625	EY 6.5-4-4631 <i>Hub diameter not ground</i>
1	1810	2.794-54	.000	5.625	EY 6.5-4-4631-1 <i>Hub diameter not ground</i>

RT-12109					
1	1710	2.500-10	3.750	3.625	CF 6-1-5541
1	1710	2.500-10	3.750	3.625	CF 6-1-5651X
1	1810	2.500-10	3.750	3.625	CF 6.5-1-2271
1	1810	2.500-10	3.750	3.625	CF 6.5-1-2351X
1	SPL140	2.500-10	3.750	5.960	EY 140-4-41-1
1	SPL140	2.500-10	3.750	5.960	EY 140-4-51-1X
1	SPL170	2.500-10	3.750	5.750	EY 170-4-471-1■
1	SPL170	2.500-10	3.750	5.750	EY 170-4-481-1X■
1	SPL250	2.500-10	3.750	6.062	EY 250-4-191-1■
1	SPL250	2.500-10	3.750	6.062	EY 250-4-201-1X■
1	1710	2.500-10	3.750	5.625	EY 6-4-6611■
1	1710	2.500-10	3.750	5.625	EY 6-4-6611-1■
1	1710	2.500-10	3.750	5.625	EY 6-4-6921-1X■
1	1710	2.500-10	3.750	5.625	EY 6-4-6921X■
1	1760	2.500-10	3.750	6.000	EY 6.3-4-651■
1	1760	2.500-10	3.750	6.031	EY 6.3-4-651-1■
1	1760	2.500-10	3.750	6.031	EY 6.3-4-781-1X■
1	1760	2.500-10	3.750	6.000	EY 6.3-4-781X■
1	1810	2.500-10	3.750	5.875	EY 6.5-4-3451■
1	1810	2.500-10	3.750	5.875	EY 6.5-4-3451-1■
1	1810	2.500-10	3.750	5.875	EY 6.5-4-3551-1X■
1	1810	2.500-10	3.750	5.875	EY 6.5-4-3551X■

RT-12509, R, RT-12513, RT-12515					
1	1810	2.750-10	3.750	4.062	CF 6.5-1-2311
1	1810	2.750-10	3.750	4.062	CF 6.5-1-2361X
1	SPL140	2.750-10	3.750	6.570	EY 140-4-81-1
1	SPL140	2.750-10	3.750	6.570	EY 140-4-91-1X
1	SPL170	2.750-10	3.750	5.850	EY 170-4-511-1
1	SPL170	2.750-10	3.750	5.850	EY 170-4-521-1X
1	SPL250	2.750-10	3.750	6.297	EY 250-4-231-1
1	SPL250	2.750-10	3.750	6.297	EY 250-4-241-1X
1	1710	2.750-10	3.750	5.750	EY 6-4-6821
1	1710	2.750-10	3.750	5.750	EY 6-4-6821-1

Pos	Series	Spline Data	Hub Dia	* to End of Hub	End Fitting Part Number
RT-12509, R, RT-12513, RT-12515 (Continued)					
1	1710	2.750-10	3.750	5.750	EY 6-4-6931-1X
1	1710	2.750-10	3.750	5.750	EY 6-4-6931X
1	1760	2.750-10	3.750	5.969	EY 6.3-4-711
1	1760	2.750-10	3.750	5.969	EY 6.3-4-711-1
1	1760	2.750-10	3.750	5.969	EY 6.3-4-791-1X
1	1760	2.750-10	3.750	5.969	EY 6.3-4-791X
1	1810	2.750-10	3.750	6.062	EY 6.5-4-3491
1	1810	2.750-10	3.750	6.062	EY 6.5-4-3491-1
1	1810	2.750-10	3.750	6.062	EY 6.5-4-3561-1X
1	1810	2.750-10	3.750	6.062	EY 6.5-4-3561X

RT-12609, RT-12610, RT-12709, RT-12710, RT-13609, RT-13709, RT-13710					
1	1710	2.500-10	3.750	3.625	CF 6-1-5541
1	1710	2.500-10	3.750	3.625	CF 6-1-5651X
1	1810	2.500-10	3.750	3.625	CF 6.5-1-2271
1	1810	2.500-10	3.750	3.625	CF 6.5-1-2351X
1	SPL140	2.500-10	3.750	5.960	EY 140-4-41-1
1	SPL140	2.500-10	3.750	5.960	EY 140-4-51-1X
1	SPL170	2.500-10	3.750	5.750	EY 170-4-471-1■
1	SPL170	2.500-10	3.750	5.750	EY 170-4-481-1X■
1	SPL250	2.500-10	3.750	6.062	EY 250-4-191-1■
1	SPL250	2.500-10	3.750	6.062	EY 250-4-201-1X■
1	1710	2.500-10	3.750	5.625	EY 6-4-6611■
1	1710	2.500-10	3.750	5.625	EY 6-4-6611-1■
1	1710	2.500-10	3.750	5.625	EY 6-4-6921-1X■
1	1710	2.500-10	3.750	5.625	EY 6-4-6921X■
1	1760	2.500-10	3.750	6.000	EY 6.3-4-651■
1	1760	2.500-10	3.750	6.031	EY 6.3-4-651-1■
1	1760	2.500-10	3.750	6.000	EY 6.3-4-781-1X■
1	1760	2.500-10	3.750	6.031	EY 6.3-4-781X■
1	1810	2.500-10	3.750	5.875	EY 6.5-4-3451■
1	1810	2.500-10	3.750	5.875	EY 6.5-4-3451-1■
1	1810	2.500-10	3.750	5.875	EY 6.5-4-3551-1X■
1	1810	2.500-10	3.750	5.875	EY 6.5-4-3551X■

RT-14109					
1	1810	2.750-10	3.750	4.062	CF 6.5-1-2311
1	1810	2.750-10	3.750	4.062	CF 6.5-1-2361X
1	SPL140	2.750-10	3.750	6.570	EY 140-4-81-1
1	SPL140	2.750-10	3.750	6.570	EY 140-4-91-1X
1	SPL170	2.750-10	3.750	5.850	EY 170-4-511-1
1	SPL170	2.750-10	3.750	5.850	EY 170-4-521-1X
1	SPL250	2.750-10	3.750	6.297	EY 250-4-231-1
1	SPL250	2.750-10	3.750	6.297	EY 250-4-241-1X

*C/L to End of Hub for EY (End Yoke); Flange Face to End of Hub for CF (Companion Flange)

■ Hub machined for speedometer gear



Pos	Series	Spline Data	Hub Dia	* to End of Hub	End Fitting Part Number
RT-14109 (Continued)					
1	1710	2.750-10	3.750	5.750	EY 6-4-6821
1	1710	2.750-10	3.750	5.750	EY 6-4-6821-1
1	1710	2.750-10	3.750	5.750	EY 6-4-6931-1X
1	1710	2.750-10	3.750	5.750	EY 6-4-6931X
1	1760	2.750-10	3.750	5.969	EY 6.3-4-711
1	1760	2.750-10	3.750	5.969	EY 6.3-4-711-1
1	1760	2.750-10	3.750	5.969	EY 6.3-4-791-1X
1	1760	2.750-10	3.750	5.969	EY 6.3-4-791X
1	1810	2.750-10	3.750	6.062	EY 6.5-4-3491
1	1810	2.750-10	3.750	6.062	EY 6.5-4-3491-1
1	1810	2.750-10	3.750	6.062	EY 6.5-4-3561-1X
1	1810	2.750-10	3.750	6.062	EY 6.5-4-3561X

RT-14209, RT-14210					
1	SPL140	2.794-54	.000	6.320	EY 140-4-201-1
1	SPL170	2.794-54	.000	5.600	EY 170-4-561-1
					<i>Hub diameter not ground</i>
1	SPL250	2.794-54	.000	5.703	EY 250-4-271-1
					<i>Hub diameter not ground</i>
1	1710	2.794-54	.000	5.625	EY 6-4-9231
1	1710	2.794-54	.000	5.625	EY 6-4-9231-1
1	1760	2.794-54	.000	5.625	EY 6.3-4-1681
					<i>Hub diameter not ground</i>
1	1760	2.794-54	.000	5.625	EY 6.3-4-1681-1
					<i>Hub diameter not ground</i>
1	1810	2.794-54	.000	5.625	EY 6.5-4-4631
					<i>Hub diameter not ground</i>
1	1810	2.794-54	.000	5.625	EY 6.5-4-4631-1
					<i>Hub diameter not ground</i>

RT-14607					
1	SPL170	2.544-49	3.750	6.000	EY 170-4-421-1X■

RT-14608, RT-14609, RT-14610, RT-14610B, RT-14613, RT-14615, RT-14709, RT-14710, RT-14715					
1	1810	2.750-10	3.750	4.062	CF 6.5-1-2311
1	1810	2.750-10	3.750	4.062	CF 6.5-1-2361X
1	SPL140	2.750-10	3.750	6.570	EY 140-4-81-1
1	SPL140	2.750-10	3.750	6.570	EY 140-4-91-1X
1	SPL170	2.750-10	3.750	5.850	EY 170-4-511-1
1	SPL170	2.750-10	3.750	5.850	EY 170-4-521-1X
1	SPL250	2.750-10	3.750	6.297	EY 250-4-231-1
1	SPL250	2.750-10	3.750	6.297	EY 250-4-241-1X
1	1710	2.750-10	3.750	5.750	EY 6-4-6821
1	1710	2.750-10	3.750	5.750	EY 6-4-6821-1
1	1710	2.750-10	3.750	5.750	EY 6-4-6931-1X
1	1710	2.750-10	3.750	5.750	EY 6-4-6931X
1	1760	2.750-10	3.750	5.969	EY 6.3-4-711
1	1760	2.750-10	3.750	5.969	EY 6.3-4-711-1
1	1760	2.750-10	3.750	5.969	EY 6.3-4-791-1X
1	1760	2.750-10	3.750	5.969	EY 6.3-4-791X
1	1810	2.750-10	3.750	6.062	EY 6.5-4-3491
1	1810	2.750-10	3.750	6.062	EY 6.5-4-3491-1
1	1810	2.750-10	3.750	6.062	EY 6.5-4-3561-1X
1	1810	2.750-10	3.750	6.062	EY 6.5-4-3561X

RT-15210					
1	SPL170	2.794-54	.000	5.600	EY 170-4-561-1
					<i>Hub diameter not ground</i>
1	SPL250	2.794-54	.000	5.703	EY 250-4-271-1
					<i>Hub diameter not ground</i>

Pos	Series	Spline Data	Hub Dia	* to End of Hub	End Fitting Part Number
RT-15610, RT-15610B, RT-15613, RT-15615, RT-15715					
1	1810	2.750-10	3.750	4.062	CF 6.5-1-2311
1	1810	2.750-10	3.750	4.062	CF 6.5-1-2361X
1	SPL140	2.750-10	3.750	6.570	EY 140-4-81-1
1	SPL140	2.750-10	3.750	6.570	EY 140-4-91-1X
1	SPL170	2.750-10	3.750	5.850	EY 170-4-511-1
1	SPL170	2.750-10	3.750	5.850	EY 170-4-521-1X
1	SPL250	2.750-10	3.750	6.297	EY 250-4-231-1
1	SPL250	2.750-10	3.750	6.297	EY 250-4-241-1X
1	1710	2.750-10	3.750	5.750	EY 6-4-6821
1	1710	2.750-10	3.750	5.750	EY 6-4-6821-1
1	1710	2.750-10	3.750	5.750	EY 6-4-6931-1X
1	1710	2.750-10	3.750	5.750	EY 6-4-6931X
1	1760	2.750-10	3.750	5.969	EY 6.3-4-711
1	1760	2.750-10	3.750	5.969	EY 6.3-4-711-1
1	1760	2.750-10	3.750	5.969	EY 6.3-4-791-1X
1	1760	2.750-10	3.750	5.969	EY 6.3-4-791X
1	1810	2.750-10	3.750	6.062	EY 6.5-4-3491
1	1810	2.750-10	3.750	6.062	EY 6.5-4-3491-1
1	1810	2.750-10	3.750	6.062	EY 6.5-4-3561-1X
1	1810	2.750-10	3.750	6.062	EY 6.5-4-3561X

RT-16210					
1	SPL170	2.794-54	.000	5.600	EY 170-4-561-1
					<i>Hub diameter not ground</i>
1	SPL250	2.794-54	.000	5.703	EY 250-4-271-1
					<i>Hub diameter not ground</i>

RT-16610, RT-16610B					
1	1810	2.750-10	3.750	4.062	CF 6.5-1-2311
1	1810	2.750-10	3.750	4.062	CF 6.5-1-2361X
1	SPL140	2.750-10	3.750	6.570	EY 140-4-81-1
1	SPL140	2.750-10	3.750	6.570	EY 140-4-91-1X
1	SPL170	2.750-10	3.750	5.850	EY 170-4-511-1
1	SPL170	2.750-10	3.750	5.850	EY 170-4-521-1X
1	SPL250	2.750-10	3.750	6.297	EY 250-4-231-1
1	SPL250	2.750-10	3.750	6.297	EY 250-4-241-1X
1	1710	2.750-10	3.750	5.750	EY 6-4-6821
1	1710	2.750-10	3.750	5.750	EY 6-4-6821-1
1	1710	2.750-10	3.750	5.750	EY 6-4-6931-1X
1	1710	2.750-10	3.750	5.750	EY 6-4-6931X
1	1760	2.750-10	3.750	5.969	EY 6.3-4-711
1	1760	2.750-10	3.750	5.969	EY 6.3-4-711-1
1	1760	2.750-10	3.750	5.969	EY 6.3-4-791-1X
1	1760	2.750-10	3.750	5.969	EY 6.3-4-791X
1	1810	2.750-10	3.750	6.062	EY 6.5-4-3491
1	1810	2.750-10	3.750	6.062	EY 6.5-4-3491-1
1	1810	2.750-10	3.750	6.062	EY 6.5-4-3561-1X
1	1810	2.750-10	3.750	6.062	EY 6.5-4-3561X

RT-16915					
1	SPL170	2.794-54	.000	5.600	EY 170-4-561-1
					<i>Hub diameter not ground</i>
1	SPL250	2.794-54	.000	5.703	EY 250-4-271-1
					<i>Hub diameter not ground</i>
1	1710	2.794-54	.000	5.625	EY 6-4-9231
1	1710	2.794-54	.000	5.625	EY 6-4-9231-1
1	1760	2.794-54	.000	5.625	EY 6.3-4-1681
					<i>Hub diameter not ground</i>
1	1760	2.794-54	.000	5.625	EY 6.3-4-1681-1
					<i>Hub diameter not ground</i>

Continued on next page

*C/L to End of Hub for EY (End Yoke); Flange Face to End of Hub for CF (Companion Flange)

■ Hub machined for speedometer gear



Important: See Safety Information in General Information Section (J300P-GI)

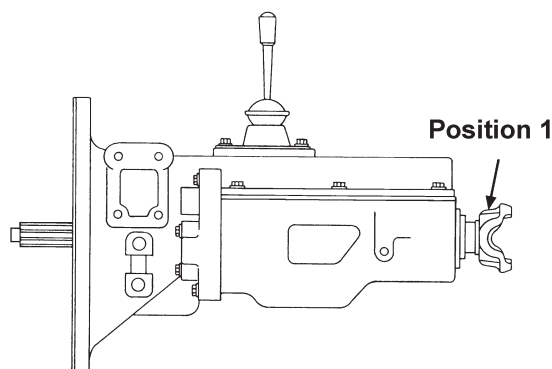

Pos	Series	Spline Data	Hub Dia	* to End of Hub	End Fitting Part Number
-----	--------	-------------	---------	-----------------	-------------------------

RT-16915 (Continued)

1	1810	2.794-54	.000	5.625	EY 6.5-4-4631 <i>Hub diameter not ground</i>
1	1810	2.794-54	.000	5.625	EY 6.5-4-4631-1 <i>Hub diameter not ground</i>

RTAO-11710, RTAO-12710, RTAO-13710

1	1710	2.500-10	3.750	3.625	CF 6-1-5541
1	1710	2.500-10	3.750	3.625	CF 6-1-5651X
1	1810	2.500-10	3.750	3.625	CF 6.5-1-2271
1	1810	2.500-10	3.750	3.625	CF 6.5-1-2351X
1	SPL140	2.500-10	3.750	5.960	EY 140-4-41-1
1	SPL140	2.500-10	3.750	5.960	EY 140-4-51-1X
1	SPL170	2.500-10	3.750	5.750	EY 170-4-471-1■
1	SPL170	2.500-10	3.750	5.750	EY 170-4-481-1X■
1	SPL250	2.500-10	3.750	6.062	EY 250-4-191-1■
1	SPL250	2.500-10	3.750	6.062	EY 250-4-201-1X■
1	1710	2.500-10	3.750	5.625	EY 6-4-6611■
1	1710	2.500-10	3.750	5.625	EY 6-4-6611-1■
1	1710	2.500-10	3.750	5.625	EY 6-4-6921-1X■
1	1710	2.500-10	3.750	5.625	EY 6-4-6921X■
1	1760	2.500-10	3.750	6.000	EY 6.3-4-651■
1	1760	2.500-10	3.750	6.031	EY 6.3-4-651-1■
1	1760	2.500-10	3.750	6.031	EY 6.3-4-781-1X■
1	1760	2.500-10	3.750	6.000	EY 6.3-4-781X■
1	1810	2.500-10	3.750	5.875	EY 6.5-4-3451■
1	1810	2.500-10	3.750	5.875	EY 6.5-4-3451-1■
1	1810	2.500-10	3.750	5.875	EY 6.5-4-3551-1X■
1	1810	2.500-10	3.750	5.875	EY 6.5-4-3551X■

RTAO-14710, RTAO-15710, RTAO-16710

1	1810	2.750-10	3.750	4.062	CF 6.5-1-2311
1	1810	2.750-10	3.750	4.062	CF 6.5-1-2361X
1	SPL140	2.750-10	3.750	6.570	EY 140-4-81-1
1	SPL140	2.750-10	3.750	6.570	EY 140-4-91-1X
1	SPL170	2.750-10	3.750	5.850	EY 170-4-511-1
1	SPL170	2.750-10	3.750	5.850	EY 170-4-521-1X
1	SPL250	2.750-10	3.750	6.297	EY 250-4-231-1
1	SPL250	2.750-10	3.750	6.297	EY 250-4-241-1X
1	1710	2.750-10	3.750	5.750	EY 6-4-6821
1	1710	2.750-10	3.750	5.750	EY 6-4-6821-1
1	1710	2.750-10	3.750	5.750	EY 6-4-6931-1X
1	1710	2.750-10	3.750	5.750	EY 6-4-6931X
1	1760	2.750-10	3.750	5.969	EY 6.3-4-711
1	1760	2.750-10	3.750	5.969	EY 6.3-4-711-1
1	1760	2.750-10	3.750	5.969	EY 6.3-4-791-1X

Pos	Series	Spline Data	Hub Dia	* to End of Hub	End Fitting Part Number
-----	--------	-------------	---------	-----------------	-------------------------

RTAO-14710, RTAO-15710, RTAO-16710 (Continued)

1	1760	2.750-10	3.750	5.969	EY 6.3-4-791X
1	1810	2.750-10	3.750	6.062	EY 6.5-4-3491
1	1810	2.750-10	3.750	6.062	EY 6.5-4-3491-1
1	1810	2.750-10	3.750	6.062	EY 6.5-4-3561-1X
1	1810	2.750-10	3.750	6.062	EY 6.5-4-3561X

RTE-12609

1	1710	2.500-10	3.750	3.625	CF 6-1-5541
1	1710	2.500-10	3.750	3.625	CF 6-1-5651X
1	1810	2.500-10	3.750	3.625	CF 6.5-1-2271
1	1810	2.500-10	3.750	3.625	CF 6.5-1-2351X
1	SPL140	2.500-10	3.750	5.960	EY 140-4-41-1
1	SPL140	2.500-10	3.750	5.960	EY 140-4-51-1X
1	SPL170	2.500-10	3.750	5.750	EY 170-4-471-1■
1	SPL170	2.500-10	3.750	5.750	EY 170-4-481-1X■
1	SPL250	2.500-10	3.750	6.062	EY 250-4-191-1■
1	SPL250	2.500-10	3.750	6.062	EY 250-4-201-1X■
1	1710	2.500-10	3.750	5.625	EY 6-4-6611■
1	1710	2.500-10	3.750	5.625	EY 6-4-6611-1■
1	1710	2.500-10	3.750	5.625	EY 6-4-6921-1X■
1	1710	2.500-10	3.750	5.625	EY 6-4-6921X■
1	1760	2.500-10	3.750	6.000	EY 6.3-4-651■
1	1760	2.500-10	3.750	6.031	EY 6.3-4-651-1■
1	1760	2.500-10	3.750	6.031	EY 6.3-4-781-1X■
1	1760	2.500-10	3.750	6.000	EY 6.3-4-781X■
1	1810	2.500-10	3.750	5.875	EY 6.5-4-3451■
1	1810	2.500-10	3.750	5.875	EY 6.5-4-3451-1■
1	1810	2.500-10	3.750	5.875	EY 6.5-4-3551-1X■
1	1810	2.500-10	3.750	5.875	EY 6.5-4-3551X■

RTF-909A

1	1710	2.500-10	3.750	3.625	CF 6-1-5541
1	1710	2.500-10	3.750	3.625	CF 6-1-5651X
1	1810	2.500-10	3.750	3.625	CF 6.5-1-2271
1	1810	2.500-10	3.750	3.625	CF 6.5-1-2351X
1	1610	2.500-10	3.750	6.125	EY 5-4-4971■
1	1710	2.500-10	3.750	5.625	EY 6-4-6611■
1	1710	2.500-10	3.750	5.625	EY 6-4-6611-1■
1	1710	2.500-10	3.750	5.625	EY 6-4-6921-1X■
1	1710	2.500-10	3.750	5.625	EY 6-4-6921X■
1	1760	2.500-10	3.750	6.000	EY 6.3-4-651■
1	1760	2.500-10	3.750	6.031	EY 6.3-4-651-1■
1	1760	2.500-10	3.750	6.031	EY 6.3-4-781-1X■
1	1760	2.500-10	3.750	6.000	EY 6.3-4-781X■

*C/L to End of Hub for EY (End Yoke); Flange Face to End of Hub for CF (Companion Flange)

■ Hub machined for speedometer gear



Pos	Series	Spline Data	Hub Dia	* to End of Hub	End Fitting Part Number
RTF-909A (Continued)					
1	1810	2.500-10	3.750	5.875	EY 6.5-4-3451■
1	1810	2.500-10	3.750	5.875	EY 6.5-4-3451-1■
1	1810	2.500-10	3.750	5.875	EY 6.5-4-3551-1X■
1	1810	2.500-10	3.750	5.875	EY 6.5-4-3551X■
RTLC-16609B					
1	1810	2.750-10	3.750	4.062	CF 6.5-1-2311
1	1810	2.750-10	3.750	4.062	CF 6.5-1-2361X
1	SPL140	2.750-10	3.750	6.570	EY 140-4-81-1
1	SPL140	2.750-10	3.750	6.570	EY 140-4-91-1X
1	SPL170	2.750-10	3.750	5.850	EY 170-4-511-1
1	SPL170	2.750-10	3.750	5.850	EY 170-4-521-1X
1	SPL250	2.750-10	3.750	6.297	EY 250-4-231-1
1	SPL250	2.750-10	3.750	6.297	EY 250-4-241-1X
1	1710	2.750-10	3.750	5.750	EY 6-4-6821
1	1710	2.750-10	3.750	5.750	EY 6-4-6821-1
1	1710	2.750-10	3.750	5.750	EY 6-4-6931-1X
1	1710	2.750-10	3.750	5.750	EY 6-4-6931X
1	1760	2.750-10	3.750	5.969	EY 6.3-4-711
1	1760	2.750-10	3.750	5.969	EY 6.3-4-711-1
1	1760	2.750-10	3.750	5.969	EY 6.3-4-791-1X
1	1760	2.750-10	3.750	5.969	EY 6.3-4-791X
1	1810	2.750-10	3.750	6.062	EY 6.5-4-3491
1	1810	2.750-10	3.750	6.062	EY 6.5-4-3491-1
1	1810	2.750-10	3.750	6.062	EY 6.5-4-3561-1X
1	1810	2.750-10	3.750	6.062	EY 6.5-4-3561X
RTLO-1210A, RTLO-11610, RTLO-12610					
1	1710	2.500-10	3.750	3.625	CF 6-1-5541
1	1710	2.500-10	3.750	3.625	CF 6-1-5651X
1	1810	2.500-10	3.750	3.625	CF 6.5-1-2271
1	1810	2.500-10	3.750	3.625	CF 6.5-1-2351X
1	SPL140	2.500-10	3.750	5.960	EY 140-4-41-1
1	SPL140	2.500-10	3.750	5.960	EY 140-4-51-1X
1	SPL170	2.500-10	3.750	5.750	EY 170-4-471-1■
1	SPL170	2.500-10	3.750	5.750	EY 170-4-481-1X■
1	SPL250	2.500-10	3.750	6.062	EY 250-4-191-1■
1	SPL250	2.500-10	3.750	6.062	EY 250-4-201-1X■
1	1710	2.500-10	3.750	5.625	EY 6-4-6611■
1	1710	2.500-10	3.750	5.625	EY 6-4-6611-1■
1	1710	2.500-10	3.750	5.625	EY 6-4-6921-1X■
1	1710	2.500-10	3.750	5.625	EY 6-4-6921X■
1	1760	2.500-10	3.750	6.000	EY 6.3-4-651■
1	1760	2.500-10	3.750	6.031	EY 6.3-4-651-1■
1	1760	2.500-10	3.750	6.031	EY 6.3-4-781-1X■
1	1760	2.500-10	3.750	6.000	EY 6.3-4-781X■
1	1810	2.500-10	3.750	5.875	EY 6.5-4-3451■
1	1810	2.500-10	3.750	5.875	EY 6.5-4-3451-1■
1	1810	2.500-10	3.750	5.875	EY 6.5-4-3551-1X■
1	1810	2.500-10	3.750	5.875	EY 6.5-4-3551X■
RTLO-12610A					
1	1810	2.500-10	3.750	3.625	CF 6.5-1-2351X
1	SPL140	2.500-10	3.750	5.960	EY 140-4-41-1
1	SPL140	2.500-10	3.750	5.960	EY 140-4-51-1X
1	SPL170	2.500-10	3.750	5.750	EY 170-4-471-1■
1	SPL170	2.500-10	3.750	5.750	EY 170-4-481-1X■
1	SPL250	2.500-10	3.750	6.062	EY 250-4-191-1■
1	SPL250	2.500-10	3.750	6.062	EY 250-4-201-1X■
1	1710	2.500-10	3.750	5.625	EY 6-4-6611■

Pos	Series	Spline Data	Hub Dia	* to End of Hub	End Fitting Part Number
RTLO-12610A (Continued)					
1	1710	2.500-10	3.750	5.625	EY 6-4-6611-1■
1	1710	2.500-10	3.750	5.625	EY 6-4-6921-1X■
1	1710	2.500-10	3.750	5.625	EY 6-4-6921X■
1	1760	2.500-10	3.750	6.000	EY 6.3-4-651■
1	1760	2.500-10	3.750	6.031	EY 6.3-4-651-1■
1	1760	2.500-10	3.750	6.031	EY 6.3-4-781-1X■
1	1810	2.500-10	3.750	5.875	EY 6.5-4-3451■
1	1810	2.500-10	3.750	5.875	EY 6.5-4-3451-1■
1	1810	2.500-10	3.750	5.875	EY 6.5-4-3551-1X■
1	1810	2.500-10	3.750	5.875	EY 6.5-4-3551X■
RTLO-12610B, RTLO-12613					
1	1710	2.500-10	3.750	3.625	CF 6-1-5541
1	1710	2.500-10	3.750	3.625	CF 6-1-5651X
1	1810	2.500-10	3.750	3.625	CF 6.5-1-2271
1	1810	2.500-10	3.750	3.625	CF 6.5-1-2351X
1	SPL140	2.500-10	3.750	5.960	EY 140-4-41-1
1	SPL140	2.500-10	3.750	5.960	EY 140-4-51-1X
1	SPL170	2.500-10	3.750	5.750	EY 170-4-471-1■
1	SPL170	2.500-10	3.750	5.750	EY 170-4-481-1X■
1	SPL250	2.500-10	3.750	6.062	EY 250-4-191-1■
1	SPL250	2.500-10	3.750	6.062	EY 250-4-201-1X■
1	1710	2.500-10	3.750	5.625	EY 6-4-6611■
1	1710	2.500-10	3.750	5.625	EY 6-4-6611-1■
1	1710	2.500-10	3.750	5.625	EY 6-4-6921-1X■
1	1710	2.500-10	3.750	5.625	EY 6-4-6921X■
1	1760	2.500-10	3.750	6.000	EY 6.3-4-651■
1	1760	2.500-10	3.750	6.031	EY 6.3-4-651-1■
1	1760	2.500-10	3.750	6.031	EY 6.3-4-781-1X■
1	1810	2.500-10	3.750	5.875	EY 6.5-4-3451■
1	1810	2.500-10	3.750	5.875	EY 6.5-4-3451-1■
1	1810	2.500-10	3.750	5.875	EY 6.5-4-3551-1X■
1	1810	2.500-10	3.750	5.875	EY 6.5-4-3551X■
RTLO-12613B, RTLO-12713, RTLO-12713A					
1	1710	2.500-10	3.750	3.625	CF 6-1-5541
1	1710	2.500-10	3.750	3.625	CF 6-1-5651X
1	1810	2.500-10	3.750	3.625	CF 6.5-1-2271
1	1810	2.500-10	3.750	3.625	CF 6.5-1-2351X
1	SPL140	2.500-10	3.750	5.960	EY 140-4-41-1
1	SPL140	2.500-10	3.750	5.960	EY 140-4-51-1X
1	SPL170	2.500-10	3.750	5.750	EY 170-4-471-1■
1	SPL170	2.500-10	3.750	5.750	EY 170-4-481-1X■
1	SPL250	2.500-10	3.750	6.062	EY 250-4-191-1■
1	SPL250	2.500-10	3.750	6.062	EY 250-4-201-1X■
1	1710	2.500-10	3.750	5.625	EY 6-4-6611■
1	1710	2.500-10	3.750	5.625	EY 6-4-6611-1■
1	1710	2.500-10	3.750	5.625	EY 6-4-6921-1X■
1	1710	2.500-10	3.750	5.625	EY 6-4-6921X■
1	1760	2.500-10	3.750	6.000	EY 6.3-4-651■
1	1760	2.500-10	3.750	6.031	EY 6.3-4-651-1■
1	1760	2.500-10	3.750	6.031	EY 6.3-4-781-1X■
1	1810	2.500-10	3.750	5.875	EY 6.5-4-3451■
1	1810	2.500-10	3.750	5.875	EY 6.5-4-3451-1■
1	1810	2.500-10	3.750	5.875	EY 6.5-4-3551-1X■
1	1810	2.500-10	3.750	5.875	EY 6.5-4-3551X■

*C/L to End of Hub for EY (End Yoke); Flange Face to End of Hub for CF (Companion Flange)

■ Hub machined for speedometer gear



Important: See Safety Information in General Information Section (J300P-GI)

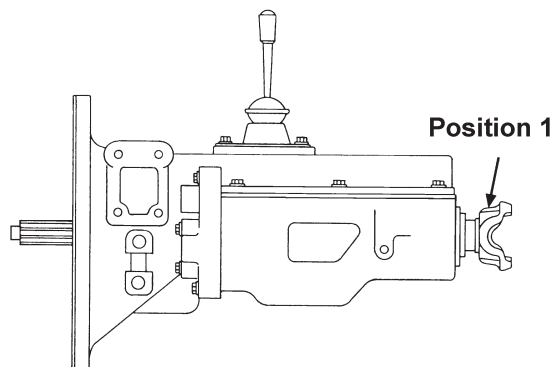

Pos	Series	Spline Data	Hub Dia	* to End of Hub	End Fitting Part Number
-----	--------	-------------	---------	-----------------	-------------------------

RTLO-12713B

1	SPL170	2.500-10	3.750	5.750	EY 170-4-471-1 ■
---	--------	----------	-------	-------	------------------

RTLO-13610

1	1710	2.500-10	3.750	3.625	CF 6-1-5541
1	1710	2.500-10	3.750	3.625	CF 6-1-5651X
1	1810	2.500-10	3.750	3.625	CF 6.5-1-2271
1	1810	2.500-10	3.750	3.625	CF 6.5-1-2351X
1	SPL140	2.500-10	3.750	5.960	EY 140-4-41-1
1	SPL140	2.500-10	3.750	5.960	EY 140-4-51-1X
1	SPL170	2.500-10	3.750	5.750	EY 170-4-471-1 ■
1	SPL170	2.500-10	3.750	5.750	EY 170-4-481-1X ■
1	SPL250	2.500-10	3.750	6.062	EY 250-4-191-1 ■
1	SPL250	2.500-10	3.750	6.062	EY 250-4-201-1X ■
1	1710	2.500-10	3.750	5.625	EY 6-4-6611 ■
1	1710	2.500-10	3.750	5.625	EY 6-4-6611-1 ■
1	1710	2.500-10	3.750	5.625	EY 6-4-6921-1X ■
1	1710	2.500-10	3.750	5.625	EY 6-4-6921X ■
1	1760	2.500-10	3.750	6.000	EY 6.3-4-651 ■
1	1760	2.500-10	3.750	6.031	EY 6.3-4-651-1 ■
1	1760	2.500-10	3.750	6.031	EY 6.3-4-781-1X ■
1	1760	2.500-10	3.750	6.000	EY 6.3-4-781X ■
1	1810	2.500-10	3.750	5.875	EY 6.5-4-3451 ■
1	1810	2.500-10	3.750	5.875	EY 6.5-4-3451-1 ■
1	1810	2.500-10	3.750	5.875	EY 6.5-4-3551-1X ■
1	1810	2.500-10	3.750	5.875	EY 6.5-4-3551X ■

RTLO-13610B

1	1710	2.500-10	3.750	3.625	CF 6-1-5651X
1	1810	2.500-10	3.750	3.625	CF 6.5-1-2351X
1	SPL140	2.500-10	3.750	5.960	EY 140-4-41-1
1	SPL140	2.500-10	3.750	5.960	EY 140-4-51-1X
1	SPL170	2.500-10	3.750	5.750	EY 170-4-471-1 ■
1	SPL170	2.500-10	3.750	5.750	EY 170-4-481-1X ■
1	SPL250	2.500-10	3.750	6.062	EY 250-4-191-1 ■
1	SPL250	2.500-10	3.750	6.062	EY 250-4-201-1X ■
1	1710	2.500-10	3.750	5.625	EY 6-4-6921-1X ■
1	1710	2.500-10	3.750	5.625	EY 6-4-6921X ■
1	1760	2.500-10	3.750	6.031	EY 6.3-4-781-1X ■
1	1760	2.500-10	3.750	6.000	EY 6.3-4-781X ■
1	1810	2.500-10	3.750	5.875	EY 6.5-4-3551-1X ■
1	1810	2.500-10	3.750	5.875	EY 6.5-4-3551X ■

Pos	Series	Spline Data	Hub Dia	* to End of Hub	End Fitting Part Number
-----	--------	-------------	---------	-----------------	-------------------------

RTLO-14610A, RTLO-14613, RTLO-14613B, RTLO-14618

1	1810	2.750-10	3.750	4.062	CF 6.5-1-2311
1	1810	2.750-10	3.750	4.062	CF 6.5-1-2361X
1	SPL140	2.750-10	3.750	6.570	EY 140-4-81-1
1	SPL140	2.750-10	3.750	6.570	EY 140-4-91-1X
1	SPL170	2.750-10	3.750	5.850	EY 170-4-511-1
1	SPL170	2.750-10	3.750	5.850	EY 170-4-521-1X
1	SPL250	2.750-10	3.750	6.297	EY 250-4-231-1
1	SPL250	2.750-10	3.750	6.297	EY 250-4-241-1X
1	1710	2.750-10	3.750	5.750	EY 6-4-6821
1	1710	2.750-10	3.750	5.750	EY 6-4-6821-1
1	1710	2.750-10	3.750	5.750	EY 6-4-6931-1X
1	1710	2.750-10	3.750	5.750	EY 6-4-6931X
1	1760	2.750-10	3.750	5.969	EY 6.3-4-711
1	1760	2.750-10	3.750	5.969	EY 6.3-4-711-1
1	1760	2.750-10	3.750	5.969	EY 6.3-4-791-1X
1	1760	2.750-10	3.750	5.969	EY 6.3-4-791X
1	1810	2.750-10	3.750	6.062	EY 6.5-4-3491
1	1810	2.750-10	3.750	6.062	EY 6.5-4-3491-1
1	1810	2.750-10	3.750	6.062	EY 6.5-4-3561-1X
1	1810	2.750-10	3.750	6.062	EY 6.5-4-3561X

RTLO-14618A

1	1810	2.750-10	3.750	4.062	CF 6.5-1-2311
1	1810	2.750-10	3.750	4.062	CF 6.5-1-2361X
1	SPL170	2.750-10	3.750	5.850	EY 170-4-511-1
1	SPL170	2.750-10	3.750	5.850	EY 170-4-521-1X
1	SPL250	2.750-10	3.750	6.297	EY 250-4-231-1
1	SPL250	2.750-10	3.750	6.297	EY 250-4-241-1X
1	1710	2.750-10	3.750	5.750	EY 6-4-6821
1	1710	2.750-10	3.750	5.750	EY 6-4-6821-1
1	1710	2.750-10	3.750	5.750	EY 6-4-6931-1X
1	1710	2.750-10	3.750	5.750	EY 6-4-6931X
1	1760	2.750-10	3.750	5.969	EY 6.3-4-711
1	1760	2.750-10	3.750	5.969	EY 6.3-4-711-1
1	1760	2.750-10	3.750	5.969	EY 6.3-4-791-1X
1	1760	2.750-10	3.750	5.969	EY 6.3-4-791X
1	1810	2.750-10	3.750	6.062	EY 6.5-4-3491
1	1810	2.750-10	3.750	6.062	EY 6.5-4-3491-1
1	1810	2.750-10	3.750	6.062	EY 6.5-4-3561-1X
1	1810	2.750-10	3.750	6.062	EY 6.5-4-3561X

*C/L to End of Hub for EY (End Yoke); Flange Face to End of Hub for CF (Companion Flange)

■ Hub machined for speedometer gear



Pos	Series	Spline Data	Hub Dia	* to End of Hub	End Fitting Part Number
RTLO-14713, RTLO-14713A, RTLO-14718, RTLO-14718B					
1	1810	2.750-10	3.750	4.062	CF 6.5-1-2311
1	1810	2.750-10	3.750	4.062	CF 6.5-1-2361X
1	SPL140	2.750-10	3.750	6.570	EY 140-4-81-1
1	SPL140	2.750-10	3.750	6.570	EY 140-4-91-1X
1	SPL170	2.750-10	3.750	5.850	EY 170-4-511-1
1	SPL170	2.750-10	3.750	5.850	EY 170-4-521-1X
1	SPL250	2.750-10	3.750	6.297	EY 250-4-231-1
1	SPL250	2.750-10	3.750	6.297	EY 250-4-241-1X
1	1710	2.750-10	3.750	5.750	EY 6-4-6821
1	1710	2.750-10	3.750	5.750	EY 6-4-6821-1
1	1710	2.750-10	3.750	5.750	EY 6-4-6931-1X
1	1710	2.750-10	3.750	5.750	EY 6-4-6931X
1	1760	2.750-10	3.750	5.969	EY 6.3-4-711
1	1760	2.750-10	3.750	5.969	EY 6.3-4-711-1
1	1760	2.750-10	3.750	5.969	EY 6.3-4-791-1X
1	1760	2.750-10	3.750	5.969	EY 6.3-4-791X
1	1810	2.750-10	3.750	6.062	EY 6.5-4-3491
1	1810	2.750-10	3.750	6.062	EY 6.5-4-3491-1
1	1810	2.750-10	3.750	6.062	EY 6.5-4-3561-1X
1	1810	2.750-10	3.750	6.062	EY 6.5-4-3561X
RTLO-14918A					
1	SPL140	2.794-54	.000	6.320	EY 140-4-201-1
1	SPL170	2.794-54	.000	5.600	EY 170-4-561-1
					<i>Hub diameter not ground</i>
1	SPL250	2.794-54	.000	5.703	EY 250-4-271-1
					<i>Hub diameter not ground</i>
1	1710	2.794-54	.000	5.625	EY 6-4-9231
1	1710	2.794-54	.000	5.625	EY 6-4-9231-1
1	1760	2.794-54	.000	5.625	EY 6.3-4-1681
					<i>Hub diameter not ground</i>
1	1760	2.794-54	.000	5.625	EY 6.3-4-1681-1
					<i>Hub diameter not ground</i>
1	1810	2.794-54	.000	5.625	EY 6.5-4-4631
					<i>Hub diameter not ground</i>
1	1810	2.794-54	.000	5.625	EY 6.5-4-4631-1
					<i>Hub diameter not ground</i>
RTLO-15610B, RTLO-16609B, RTLO-16610B, RTLO-16613B, RTLO-16618, RTLO-16618A					
1	1810	2.750-10	3.750	4.062	CF 6.5-1-2311
1	1810	2.750-10	3.750	4.062	CF 6.5-1-2361X
1	SPL140	2.750-10	3.750	6.570	EY 140-4-81-1
1	SPL140	2.750-10	3.750	6.570	EY 140-4-91-1X
1	SPL170	2.750-10	3.750	5.850	EY 170-4-511-1
1	SPL170	2.750-10	3.750	5.850	EY 170-4-521-1X
1	SPL250	2.750-10	3.750	6.297	EY 250-4-231-1
1	SPL250	2.750-10	3.750	6.297	EY 250-4-241-1X
1	1710	2.750-10	3.750	5.750	EY 6-4-6821
1	1710	2.750-10	3.750	5.750	EY 6-4-6821-1
1	1710	2.750-10	3.750	5.750	EY 6-4-6931-1X
1	1710	2.750-10	3.750	5.750	EY 6-4-6931X
1	1760	2.750-10	3.750	5.969	EY 6.3-4-711
1	1760	2.750-10	3.750	5.969	EY 6.3-4-711-1
1	1760	2.750-10	3.750	5.969	EY 6.3-4-791-1X
1	1760	2.750-10	3.750	5.969	EY 6.3-4-791X
1	1810	2.750-10	3.750	6.062	EY 6.5-4-3491
1	1810	2.750-10	3.750	6.062	EY 6.5-4-3491-1
1	1810	2.750-10	3.750	6.062	EY 6.5-4-3561-1X
1	1810	2.750-10	3.750	6.062	EY 6.5-4-3561X

Pos	Series	Spline Data	Hub Dia	* to End of Hub	End Fitting Part Number
RTLO-16713					
1	1810	2.750-10	3.750	4.062	CF 6.5-1-2311
1	1810	2.750-10	3.750	4.062	CF 6.5-1-2361X
1	SPL140	2.750-10	3.750	6.570	EY 140-4-81-1
1	SPL140	2.750-10	3.750	6.570	EY 140-4-91-1X
1	SPL170	2.750-10	3.750	5.850	EY 170-4-521-1X
1	1710	2.750-10	3.750	5.750	EY 6-4-6821
1	1710	2.750-10	3.750	5.750	EY 6-4-6821-1
1	1710	2.750-10	3.750	5.750	EY 6-4-6931-1X
1	1710	2.750-10	3.750	5.750	EY 6-4-6931X
1	1760	2.750-10	3.750	5.969	EY 6.3-4-711
1	1760	2.750-10	3.750	5.969	EY 6.3-4-711-1
1	1760	2.750-10	3.750	5.969	EY 6.3-4-791-1X
1	1760	2.750-10	3.750	5.969	EY 6.3-4-791X
1	1810	2.750-10	3.750	6.062	EY 6.5-4-3491
1	1810	2.750-10	3.750	6.062	EY 6.5-4-3491-1
1	1810	2.750-10	3.750	6.062	EY 6.5-4-3561-1X
1	1810	2.750-10	3.750	6.062	EY 6.5-4-3561X
RTLO-16713A, RTLO-16718, RTLO-16718B					
1	1810	2.750-10	3.750	4.062	CF 6.5-1-2311
1	1810	2.750-10	3.750	4.062	CF 6.5-1-2361X
1	SPL140	2.750-10	3.750	6.570	EY 140-4-81-1
1	SPL140	2.750-10	3.750	6.570	EY 140-4-91-1X
1	SPL170	2.750-10	3.750	5.850	EY 170-4-511-1
1	SPL170	2.750-10	3.750	5.850	EY 170-4-521-1X
1	SPL250	2.750-10	3.750	6.297	EY 250-4-231-1
1	SPL250	2.750-10	3.750	6.297	EY 250-4-241-1X
1	1710	2.750-10	3.750	5.750	EY 6-4-6821
1	1710	2.750-10	3.750	5.750	EY 6-4-6821-1
1	1710	2.750-10	3.750	5.750	EY 6-4-6931-1X
1	1710	2.750-10	3.750	5.750	EY 6-4-6931X
1	1760	2.750-10	3.750	5.969	EY 6.3-4-711
1	1760	2.750-10	3.750	5.969	EY 6.3-4-711-1
1	1760	2.750-10	3.750	5.969	EY 6.3-4-791-1X
1	1760	2.750-10	3.750	5.969	EY 6.3-4-791X
1	1810	2.750-10	3.750	6.062	EY 6.5-4-3491
1	1810	2.750-10	3.750	6.062	EY 6.5-4-3491-1
1	1810	2.750-10	3.750	6.062	EY 6.5-4-3561-1X
1	1810	2.750-10	3.750	6.062	EY 6.5-4-3561X
RTLO-167188					
1	SPL170	2.750-10	3.750	5.850	EY 170-4-521-1X
RTLO-16913					
1	SPL140	2.794-54	.000	6.320	EY 140-4-201-1
1	SPL170	2.794-54	.000	5.600	EY 170-4-561-1
					<i>Hub diameter not ground</i>
1	SPL250	2.794-54	.000	5.703	EY 250-4-271-1
					<i>Hub diameter not ground</i>
1	1710	2.794-54	.000	5.625	EY 6-4-9231
1	1760	2.794-54	.000	5.625	EY 6.3-4-1681
					<i>Hub diameter not ground</i>
1	1760	2.794-54	.000	5.625	EY 6.3-4-1681-1
					<i>Hub diameter not ground</i>
1	1810	2.794-54	.000	5.625	EY 6.5-4-4631
					<i>Hub diameter not ground</i>
1	1810	2.794-54	.000	5.625	EY 6.5-4-4631-1
					<i>Hub diameter not ground</i>

*C/L to End of Hub for EY (End Yoke); Flange Face to End of Hub for CF (Companion Flange)

■ Hub machined for speedometer gear



Important: See Safety Information in General Information Section (J300P-GI)

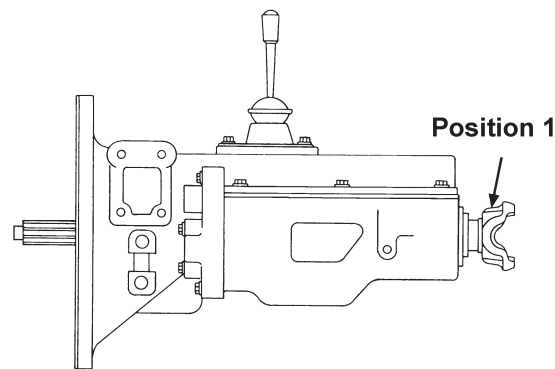

Pos	Series	Spline Data	Hub Dia	* to End of Hub	End Fitting Part Number
-----	--------	-------------	---------	-----------------	-------------------------

RTLO-16918					
1	SPL140	2.794-54	.000	6.320	EY 140-4-201-1
1	SPL170	2.794-54	.000	5.600	EY 170-4-561-1 <i>Hub diameter not ground</i>
1	1710	2.794-54	.000	5.625	EY 6-4-9231
1	1710	2.794-54	.000	5.625	EY 6-4-9231-1
1	1760	2.794-54	.000	5.625	EY 6.3-4-1681 <i>Hub diameter not ground</i>
1	1760	2.794-54	.000	5.625	EY 6.3-4-1681-1 <i>Hub diameter not ground</i>
1	1810	2.794-54	.000	5.625	EY 6.5-4-4631 <i>Hub diameter not ground</i>
1	1810	2.794-54	.000	5.625	EY 6.5-4-4631-1 <i>Hub diameter not ground</i>

RTLO-18718, RTLO-18718B					
1	1810	2.750-10	3.750	4.062	CF 6.5-1-2311
1	1810	2.750-10	3.750	4.062	CF 6.5-1-2361X
1	SPL140	2.750-10	3.750	6.570	EY 140-4-81-1
1	SPL140	2.750-10	3.750	6.570	EY 140-4-91-1X
1	SPL170	2.750-10	3.750	5.850	EY 170-4-511-1
1	SPL170	2.750-10	3.750	5.850	EY 170-4-521-1X
1	SPL250	2.750-10	3.750	6.297	EY 250-4-231-1
1	SPL250	2.750-10	3.750	6.297	EY 250-4-241-1X
1	1710	2.750-10	3.750	5.750	EY 6-4-6821
1	1710	2.750-10	3.750	5.750	EY 6-4-6821-1
1	1710	2.750-10	3.750	5.750	EY 6-4-6931-1X
1	1710	2.750-10	3.750	5.750	EY 6-4-6931X
1	1760	2.750-10	3.750	5.969	EY 6.3-4-711
1	1760	2.750-10	3.750	5.969	EY 6.3-4-711-1
1	1760	2.750-10	3.750	5.969	EY 6.3-4-791-1X
1	1760	2.750-10	3.750	5.969	EY 6.3-4-791X
1	1810	2.750-10	3.750	6.062	EY 6.5-4-3491
1	1810	2.750-10	3.750	6.062	EY 6.5-4-3491-1
1	1810	2.750-10	3.750	6.062	EY 6.5-4-3561-1X
1	1810	2.750-10	3.750	6.062	EY 6.5-4-3561X

RTLO-18913, RTLO-18918, RTLO-20918					
1	SPL140	2.794-54	.000	6.320	EY 140-4-201-1
1	SPL170	2.794-54	.000	5.600	EY 170-4-561-1 <i>Hub diameter not ground</i>
1	1710	2.794-54	.000	5.625	EY 6-4-9231
1	1710	2.794-54	.000	5.625	EY 6-4-9231-1
1	1760	2.794-54	.000	5.625	EY 6.3-4-1681 <i>Hub diameter not ground</i>
1	1760	2.794-54	.000	5.625	EY 6.3-4-1681-1 <i>Hub diameter not ground</i>

Pos	Series	Spline Data	Hub Dia	* to End of Hub	End Fitting Part Number
-----	--------	-------------	---------	-----------------	-------------------------

RTLO-18913, RTLO-18918, RTLO-20918 (Continued)					
1	1810	2.794-54	.000	5.625	EY 6.5-4-4631 <i>Hub diameter not ground</i>
1	1810	2.794-54	.000	5.625	EY 6.5-4-4631-1 <i>Hub diameter not ground</i>

RTO-910, RTO-913, RTO-915					
1	1710	2.500-10	3.750	3.625	CF 6-1-5541
1	1710	2.500-10	3.750	3.625	CF 6-1-5651X
1	1810	2.500-10	3.750	3.625	CF 6.5-1-2271
1	1810	2.500-10	3.750	3.625	CF 6.5-1-2351X
1	SPL140	2.500-10	3.750	5.960	EY 140-4-41-1
1	SPL140	2.500-10	3.750	5.960	EY 140-4-51-1X
1	SPL170	2.500-10	3.750	5.750	EY 170-4-471-1■
1	SPL170	2.500-10	3.750	5.750	EY 170-4-481-1X■
1	SPL250	2.500-10	3.750	6.062	EY 250-4-191-1■
1	SPL250	2.500-10	3.750	6.062	EY 250-4-201-1X■
1	1610	2.500-10	3.750	6.125	EY 5-4-4971■
1	1710	2.500-10	3.750	5.625	EY 6-4-6611■
1	1710	2.500-10	3.750	5.625	EY 6-4-6611-1■
1	1710	2.500-10	3.750	5.625	EY 6-4-6921-1X■
1	1710	2.500-10	3.750	5.625	EY 6-4-6921X■
1	1760	2.500-10	3.750	6.000	EY 6.3-4-651■
1	1760	2.500-10	3.750	6.031	EY 6.3-4-651-1■
1	1760	2.500-10	3.750	6.031	EY 6.3-4-781-1X■
1	1760	2.500-10	3.750	6.000	EY 6.3-4-781X■
1	1810	2.500-10	3.750	5.875	EY 6.5-4-3451■
1	1810	2.500-10	3.750	5.875	EY 6.5-4-3451-1■
1	1810	2.500-10	3.750	5.875	EY 6.5-4-3551-1X■
1	1810	2.500-10	3.750	5.875	EY 6.5-4-3551X■

RTO-958LL					
1	1710	2.500-10	3.750	3.625	CF 6-1-5541
1	1710	2.500-10	3.750	3.625	CF 6-1-5651X
1	SPL140	2.500-10	3.750	5.960	EY 140-4-41-1
1	SPL140	2.500-10	3.750	5.960	EY 140-4-51-1X
1	SPL170	2.500-10	3.750	5.750	EY 170-4-471-1■
1	SPL170	2.500-10	3.750	5.750	EY 170-4-481-1X■
1	SPL250	2.500-10	3.750	6.062	EY 250-4-191-1■
1	SPL250	2.500-10	3.750	6.062	EY 250-4-201-1X■
1	1710	2.500-10	3.750	5.625	EY 6-4-6921-1X■
1	1710	2.500-10	3.750	5.625	EY 6-4-6921X■
1	1760	2.500-10	3.750	6.000	EY 6.3-4-651■
1	1760	2.500-10	3.750	6.031	EY 6.3-4-651-1■
1	1760	2.500-10	3.750	6.031	EY 6.3-4-781-1X■
1	1760	2.500-10	3.750	6.000	EY 6.3-4-781X■

*C/L to End of Hub for EY (End Yoke); Flange Face to End of Hub for CF (Companion Flange)

■ Hub machined for speedometer gear



Pos	Series	Spline Data	Hub Dia	* to End of Hub	End Fitting Part Number
RTO-958LL (Continued)					
1	1810	2.500-10	3.750	5.875	EY 6.5-4-3451■
1	1810	2.500-10	3.750	5.875	EY 6.5-4-3451-1■
1	1810	2.500-10	3.750	5.875	EY 6.5-4-3551-1X■
1	1810	2.500-10	3.750	5.875	EY 6.5-4-3551X■
RTO-1110					
1	1710	2.500-10	3.750	3.625	CF 6-1-5651X
1	1810	2.500-10	3.750	3.625	CF 6.5-1-2271
1	1810	2.500-10	3.750	3.625	CF 6.5-1-2351X
1	1610	2.500-10	3.750	6.125	EY 5-4-4971■
1	1710	2.500-10	3.750	5.625	EY 6-4-6611■
1	1710	2.500-10	3.750	5.625	EY 6-4-6611-1■
1	1710	2.500-10	3.750	5.625	EY 6-4-6921-1X■
1	1710	2.500-10	3.750	5.625	EY 6-4-6921X■
1	1760	2.500-10	3.750	6.000	EY 6.3-4-651■
1	1760	2.500-10	3.750	6.031	EY 6.3-4-651-1■
1	1760	2.500-10	3.750	6.031	EY 6.3-4-781-1X■
1	1760	2.500-10	3.750	6.000	EY 6.3-4-781X■
1	1810	2.500-10	3.750	5.875	EY 6.5-4-3451■
1	1810	2.500-10	3.750	5.875	EY 6.5-4-3451-1■
1	1810	2.500-10	3.750	5.875	EY 6.5-4-3551-1X■
1	1810	2.500-10	3.750	5.875	EY 6.5-4-3551X■
RTO-1157					
1	1810	2.750-10	3.750	4.062	CF 6.5-1-2361X <i>Can be used w/brake</i>
1	SPL140	2.750-10	3.750	6.570	EY 140-4-81-1
1	SPL140	2.750-10	3.750	6.570	EY 140-4-91-1X <i>Can be used w/brake</i>
1	SPL170	2.750-10	3.750	5.850	EY 170-4-511-1 <i>Can be used w/brake</i>
1	SPL170	2.750-10	3.750	5.850	EY 170-4-521-1X <i>Can be used w/brake</i>
1	SPL250	2.750-10	3.750	6.297	EY 250-4-231-1 <i>Can be used w/brake</i>
1	SPL250	2.750-10	3.750	6.297	EY 250-4-241-1X <i>Can be used w/brake</i>
1	1710	2.750-10	3.750	5.750	EY 6-4-6931-1X <i>Can be used w/brake</i>
1	1710	2.750-10	3.750	5.750	EY 6-4-6931X <i>Can be used w/brake</i>
1	1760	2.750-10	3.750	5.969	EY 6.3-4-711 <i>Can be used w/brake</i>
1	1760	2.750-10	3.750	5.969	EY 6.3-4-711-1 <i>Can be used w/brake</i>
1	1760	2.750-10	3.750	5.969	EY 6.3-4-791-1X <i>Can be used w/brake</i>
1	1760	2.750-10	3.750	5.969	EY 6.3-4-791X <i>Can be used w/brake</i>
1	1810	2.750-10	3.750	6.062	EY 6.5-4-3561-1X <i>Can be used w/brake</i>
1	1810	2.750-10	3.750	6.062	EY 6.5-4-3561X <i>Can be used w/brake</i>
RTO-1157-DL, RTO-1157-DLL					
1	1810	2.750-10	3.750	4.062	CF 6.5-1-2311
1	1810	2.750-10	3.750	4.062	CF 6.5-1-2361X
1	SPL170	2.750-10	3.750	5.850	EY 170-4-511-1
1	SPL170	2.750-10	3.750	5.850	EY 170-4-521-1X
1	SPL250	2.750-10	3.750	6.297	EY 250-4-231-1
1	SPL250	2.750-10	3.750	6.297	EY 250-4-241-1X
1	1710	2.750-10	3.750	5.750	EY 6-4-6821
1	1710	2.750-10	3.750	5.750	EY 6-4-6821-1

Pos	Series	Spline Data	Hub Dia	* to End of Hub	End Fitting Part Number
RTO-1157-DL, RTO-1157-DLL (Continued)					
1	1710	2.750-10	3.750	5.750	EY 6-4-6931-1X
1	1710	2.750-10	3.750	5.750	EY 6-4-6931X
1	1760	2.750-10	3.750	5.969	EY 6.3-4-711
1	1760	2.750-10	3.750	5.969	EY 6.3-4-711-1
1	1760	2.750-10	3.750	5.969	EY 6.3-4-791-1X
1	1760	2.750-10	3.750	5.969	EY 6.3-4-791X
1	1810	2.750-10	3.750	6.062	EY 6.5-4-3491
1	1810	2.750-10	3.750	6.062	EY 6.5-4-3491-1
1	1810	2.750-10	3.750	6.062	EY 6.5-4-3561-1X
1	1810	2.750-10	3.750	6.062	EY 6.5-4-3561X
RTO-1213, RTO-1258LL, RTO-2008					
1	1810	2.750-10	3.750	4.062	CF 6.5-1-2311
1	1810	2.750-10	3.750	4.062	CF 6.5-1-2361X
1	SPL140	2.750-10	3.750	6.570	EY 140-4-81-1
1	SPL140	2.750-10	3.750	6.570	EY 140-4-91-1X
1	SPL170	2.750-10	3.750	5.850	EY 170-4-511-1
1	SPL170	2.750-10	3.750	5.850	EY 170-4-521-1X
1	SPL250	2.750-10	3.750	6.297	EY 250-4-231-1
1	SPL250	2.750-10	3.750	6.297	EY 250-4-241-1X
1	1710	2.750-10	3.750	5.750	EY 6-4-6821
1	1710	2.750-10	3.750	5.750	EY 6-4-6821-1
1	1710	2.750-10	3.750	5.750	EY 6-4-6931-1X
1	1710	2.750-10	3.750	5.750	EY 6-4-6931X
1	1760	2.750-10	3.750	5.969	EY 6.3-4-711
1	1760	2.750-10	3.750	5.969	EY 6.3-4-711-1
1	1760	2.750-10	3.750	5.969	EY 6.3-4-791-1X
1	1760	2.750-10	3.750	5.969	EY 6.3-4-791X
1	1810	2.750-10	3.750	6.062	EY 6.5-4-3491-1
1	1810	2.750-10	3.750	6.062	EY 6.5-4-3561-1X
1	1810	2.750-10	3.750	6.062	EY 6.5-4-3561X
RTO-6610					
1	1610	2.250-10	3.500	3.625	CF 5-1-6331
1	1710	2.250-10	3.500	3.688	CF 6-1-951
1	1810	2.250-10	3.500	3.688	CF 6.5-1-151
1	SPL90	2.250-10	3.500	5.219	EY 90-4-151-1X
1	SPL90	2.250-10	3.500	5.219	EY 90-4-401-1
1	1550	2.250-10	3.500	5.125	EY 4-4-3501-1
1	1610	2.250-10	3.500	5.750	EY 5-4-4961
1	1610	2.250-10	3.500	5.750	EY 5-4-4961-1
1	1610	2.250-10	3.750	5.750	EY 5-4-7381-1
1	1610	2.250-10	3.750	5.750	EY 5-4-7391-1X
1	1710	2.250-10	3.500	5.250	EY 6-4-6861
1	1710	2.250-10	3.500	5.250	EY 6-4-6861-1
1	1710	2.250-10	3.500	5.250	EY 6-4-6901-1X
1	1710	2.250-10	3.750	5.250	EY 6-4-7371-1
1	1710	2.250-10	3.750	5.250	EY 6-4-7381-1X
1	1760	2.250-10	3.750	5.625	EY 6.3-4-1091-1
1	1760	2.250-10	3.750	5.625	EY 6.3-4-1101-1X
1	1760	2.250-10	3.500	5.656	EY 6.3-4-701-1
1	1760	2.250-10	3.500	5.656	EY 6.3-4-761-1X
1	1810	2.250-10	3.500	5.844	EY 6.5-4-2021
RTO-6613, RTO-9509A, RTO-9509B, RTO-9513					
1	1710	2.500-10	3.750	3.625	CF 6-1-5541
1	1710	2.500-10	3.750	3.625	CF 6-1-5651X
1	1810	2.500-10	3.750	3.625	CF 6.5-1-2271

Continued on next page

*C/L to End of Hub for EY (End Yoke); Flange Face to End of Hub for CF (Companion Flange)

■ Hub machined for speedometer gear



Important: See Safety Information in General Information Section (J300P-GI)

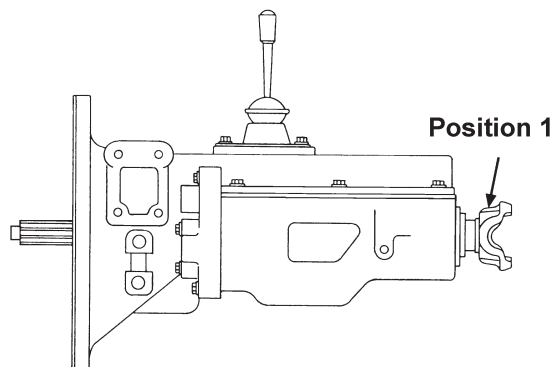

Pos	Series	Spline Data	Hub Dia	* to End of Hub	End Fitting Part Number
-----	--------	-------------	---------	-----------------	-------------------------

RTO-6613, RTO-9509A, RTO-9509B, RTO-9513 (Continued)

1	1810	2.500-10	3.750	3.625	CF 6.5-1-2351X
1	SPL140	2.500-10	3.750	5.960	EY 140-4-41-1
1	SPL140	2.500-10	3.750	5.960	EY 140-4-51-1X
1	SPL170	2.500-10	3.750	5.750	EY 170-4-471-1■
1	SPL170	2.500-10	3.750	5.750	EY 170-4-481-1X■
1	SPL250	2.500-10	3.750	6.062	EY 250-4-191-1■
1	SPL250	2.500-10	3.750	6.062	EY 250-4-201-1X■
1	1610	2.500-10	3.750	6.125	EY 5-4-4971■
1	1710	2.500-10	3.750	5.625	EY 6-4-6611■
1	1710	2.500-10	3.750	5.625	EY 6-4-6611-1■
1	1710	2.500-10	3.750	5.625	EY 6-4-6921-1X■
1	1710	2.500-10	3.750	5.625	EY 6-4-6921X■
1	1760	2.500-10	3.750	6.000	EY 6.3-4-651■
1	1760	2.500-10	3.750	6.031	EY 6.3-4-651-1■
1	1760	2.500-10	3.750	6.031	EY 6.3-4-781-1X■
1	1760	2.500-10	3.750	6.031	EY 6.3-4-781X■
1	1760	2.500-10	3.750	6.000	EY 6.3-4-781X■
1	1810	2.500-10	3.750	5.875	EY 6.5-4-3451■
1	1810	2.500-10	3.750	5.875	EY 6.5-4-3451-1■
1	1810	2.500-10	3.750	5.875	EY 6.5-4-3551-1X■
1	1810	2.500-10	3.750	5.875	EY 6.5-4-3551X■

RTO-11109

1	1810	2.750-10	3.750	4.062	CF 6.5-1-2311
1	1810	2.750-10	3.750	4.062	CF 6.5-1-2361X
1	SPL140	2.750-10	3.750	6.570	EY 140-4-81-1
1	SPL140	2.750-10	3.750	6.570	EY 140-4-91-1X
1	SPL170	2.750-10	3.750	5.850	EY 170-4-511-1
1	SPL170	2.750-10	3.750	5.850	EY 170-4-521-1X
1	SPL250	2.750-10	3.750	6.297	EY 250-4-231-1
1	SPL250	2.750-10	3.750	6.297	EY 250-4-241-1X
1	1710	2.750-10	3.750	5.750	EY 6-4-6821
1	1710	2.750-10	3.750	5.750	EY 6-4-6821-1
1	1710	2.750-10	3.750	5.750	EY 6-4-6931-1X
1	1710	2.750-10	3.750	5.750	EY 6-4-6931X
1	1760	2.750-10	3.750	5.969	EY 6.3-4-711
1	1760	2.750-10	3.750	5.969	EY 6.3-4-711-1
1	1760	2.750-10	3.750	5.969	EY 6.3-4-791-1X
1	1760	2.750-10	3.750	5.969	EY 6.3-4-791X
1	1810	2.750-10	3.750	6.062	EY 6.5-4-3491
1	1810	2.750-10	3.750	6.062	EY 6.5-4-3491-1
1	1810	2.750-10	3.750	6.062	EY 6.5-4-3561-1X
1	1810	2.750-10	3.750	6.062	EY 6.5-4-3561X

Pos	Series	Spline Data	Hub Dia	* to End of Hub	End Fitting Part Number
-----	--------	-------------	---------	-----------------	-------------------------

RTO-11509

1	1710	2.500-10	3.750	3.625	CF 6-1-5541
1	1710	2.500-10	3.750	3.625	CF 6-1-5651X
1	1810	2.500-10	3.750	3.625	CF 6.5-1-2271
1	1810	2.500-10	3.750	3.625	CF 6.5-1-2351X
1	SPL140	2.750-10	3.750	6.570	EY 140-4-81-1
1	SPL140	2.750-10	3.750	6.570	EY 140-4-91-1X
1	1610	2.500-10	3.750	6.125	EY 5-4-4971■
1	1710	2.500-10	3.750	5.625	EY 6-4-6611■
1	1710	2.500-10	3.750	5.625	EY 6-4-6611-1■
1	1710	2.500-10	3.750	5.625	EY 6-4-6921-1X■
1	1710	2.500-10	3.750	5.625	EY 6-4-6921X■
1	1760	2.500-10	3.750	6.000	EY 6.3-4-651■
1	1760	2.500-10	3.750	6.031	EY 6.3-4-651-1■
1	1760	2.500-10	3.750	6.031	EY 6.3-4-781-1X■
1	1760	2.500-10	3.750	6.000	EY 6.3-4-781X■
1	1810	2.500-10	3.750	5.875	EY 6.5-4-3451■
1	1810	2.500-10	3.750	5.875	EY 6.5-4-3451-1■
1	1810	2.500-10	3.750	5.875	EY 6.5-4-3551-1X■
1	1810	2.500-10	3.750	5.875	EY 6.5-4-3551X■

RTO-11607-L, RTO-11607-LL, RTO-11607L, RTO-11607LL

1	1810	2.750-10	3.750	4.062	CF 6.5-1-2311
1	1810	2.750-10	3.750	4.062	CF 6.5-1-2361X
1	SPL140	2.750-10	3.750	6.570	EY 140-4-81-1
1	SPL140	2.750-10	3.750	6.570	EY 140-4-91-1X
1	SPL170	2.750-10	3.750	5.850	EY 170-4-511-1
1	SPL170	2.750-10	3.750	5.850	EY 170-4-521-1X
1	SPL250	2.750-10	3.750	6.297	EY 250-4-231-1
1	SPL250	2.750-10	3.750	6.297	EY 250-4-241-1X
1	1710	2.750-10	3.750	5.750	EY 6-4-6821
1	1710	2.750-10	3.750	5.750	EY 6-4-6821-1
1	1710	2.750-10	3.750	5.750	EY 6-4-6931-1X
1	1710	2.750-10	3.750	5.750	EY 6-4-6931X
1	1760	2.750-10	3.750	5.969	EY 6.3-4-711
1	1760	2.750-10	3.750	5.969	EY 6.3-4-711-1
1	1760	2.750-10	3.750	5.969	EY 6.3-4-791-1X
1	1760	2.750-10	3.750	5.969	EY 6.3-4-791X
1	1810	2.750-10	3.750	6.062	EY 6.5-4-3491
1	1810	2.750-10	3.750	6.062	EY 6.5-4-3491-1
1	1810	2.750-10	3.750	6.062	EY 6.5-4-3561-1X
1	1810	2.750-10	3.750	6.062	EY 6.5-4-3561X

*C/L to End of Hub for EY (End Yoke); Flange Face to End of Hub for CF (Companion Flange)

■ Hub machined for speedometer gear



Pos	Series	Spline Data	Hub Dia	* to End of Hub	End Fitting Part Number
RTO-11608LL					
1	1710	2.500-10	3.750	3.625	CF 6-1-5541
1	1710	2.500-10	3.750	3.625	CF 6-1-5651X
1	1810	2.500-10	3.750	3.625	CF 6.5-1-2271
1	1810	2.500-10	3.750	3.625	CF 6.5-1-2351X
1	SPL140	2.500-10	3.750	5.960	EY 140-4-41-1
1	SPL140	2.500-10	3.750	5.960	EY 140-4-51-1X
1	SPL170	2.500-10	3.750	5.750	EY 170-4-481-1X■
1	SPL250	2.500-10	3.750	6.062	EY 250-4-201-1X■
1	1610	2.500-10	3.750	6.125	EY 5-4-4971■
1	1710	2.500-10	3.750	5.625	EY 6-4-6611■
1	1710	2.500-10	3.750	5.625	EY 6-4-6611-1■
1	1710	2.500-10	3.750	5.625	EY 6-4-6921-1X■
1	1710	2.500-10	3.750	5.625	EY 6-4-6921X■
1	1760	2.500-10	3.750	6.000	EY 6.3-4-651■
1	1760	2.500-10	3.750	6.031	EY 6.3-4-651-1■
1	1760	2.500-10	3.750	6.031	EY 6.3-4-781-1X■
1	1760	2.500-10	3.750	6.000	EY 6.3-4-781X■
1	1810	2.500-10	3.750	5.875	EY 6.5-4-3451■
1	1810	2.500-10	3.750	5.875	EY 6.5-4-3451-1■
1	1810	2.500-10	3.750	5.875	EY 6.5-4-3551-1X■
1	1810	2.500-10	3.750	5.875	EY 6.5-4-3551X■

Pos	Series	Spline Data	Hub Dia	* to End of Hub	End Fitting Part Number
RTO-11609, RTO-11610, RTO-11613					
1	1710	2.500-10	3.750	3.625	CF 6-1-5541
1	1710	2.500-10	3.750	3.625	CF 6-1-5651X
1	1810	2.500-10	3.750	3.625	CF 6.5-1-2271
1	1810	2.500-10	3.750	3.625	CF 6.5-1-2351X
1	1610	2.500-10	3.750	6.125	EY 5-4-4971■
1	1710	2.500-10	3.750	5.625	EY 6-4-6611■
1	1710	2.500-10	3.750	5.625	EY 6-4-6611-1■
1	1710	2.500-10	3.750	5.625	EY 6-4-6921-1X■
1	1710	2.500-10	3.750	5.625	EY 6-4-6921X■
1	1760	2.500-10	3.750	6.000	EY 6.3-4-651■
1	1760	2.500-10	3.750	6.031	EY 6.3-4-651-1■
1	1760	2.500-10	3.750	6.031	EY 6.3-4-781-1X■
1	1760	2.500-10	3.750	6.000	EY 6.3-4-781X■
1	1810	2.500-10	3.750	5.875	EY 6.5-4-3451■
1	1810	2.500-10	3.750	5.875	EY 6.5-4-3451-1■
1	1810	2.500-10	3.750	5.875	EY 6.5-4-3551-1X■
1	1810	2.500-10	3.750	5.875	EY 6.5-4-3551X■

Pos	Series	Spline Data	Hub Dia	* to End of Hub	End Fitting Part Number
RTO-11615					
1	1710	2.500-10	3.750	3.625	CF 6-1-5541
1	1710	2.500-10	3.750	3.625	CF 6-1-5651X
1	1610	2.500-10	3.750	6.125	EY 5-4-4971■
1	1710	2.500-10	3.750	5.625	EY 6-4-6611■
1	1710	2.500-10	3.750	5.625	EY 6-4-6611-1■
1	1710	2.500-10	3.750	5.625	EY 6-4-6921-1X■
1	1710	2.500-10	3.750	5.625	EY 6-4-6921X■
1	1760	2.500-10	3.750	6.000	EY 6.3-4-651■
1	1760	2.500-10	3.750	6.031	EY 6.3-4-651-1■
1	1760	2.500-10	3.750	6.031	EY 6.3-4-781-1X■
1	1760	2.500-10	3.750	6.000	EY 6.3-4-781X■
1	1810	2.500-10	3.750	5.875	EY 6.5-4-3451■
1	1810	2.500-10	3.750	5.875	EY 6.5-4-3451-1■
1	1810	2.500-10	3.750	5.875	EY 6.5-4-3551-1X■
1	1810	2.500-10	3.750	5.875	EY 6.5-4-3551X■

Pos	Series	Spline Data	Hub Dia	* to End of Hub	End Fitting Part Number
RTO-11618					
1	1710	2.500-10	3.750	3.625	CF 6-1-5651X
1	SPL140	2.500-10	3.750	5.960	EY 140-4-41-1
1	SPL140	2.500-10	3.750	5.960	EY 140-4-51-1X
1	SPL170	2.500-10	3.750	5.750	EY 170-4-471-1■
1	SPL170	2.500-10	3.750	5.750	EY 170-4-481-1X■
1	SPL250	2.500-10	3.750	6.062	EY 250-4-191-1■
1	SPL250	2.500-10	3.750	6.062	EY 250-4-201-1X■
1	1710	2.500-10	3.750	5.625	EY 6-4-6611■
1	1710	2.500-10	3.750	5.625	EY 6-4-6611-1■
1	1710	2.500-10	3.750	5.625	EY 6-4-6921-1X■
1	1710	2.500-10	3.750	5.625	EY 6-4-6921X■
1	1760	2.500-10	3.750	6.000	EY 6.3-4-651■
1	1760	2.500-10	3.750	6.031	EY 6.3-4-651-1■
1	1760	2.500-10	3.750	6.031	EY 6.3-4-781-1X■
1	1760	2.500-10	3.750	6.000	EY 6.3-4-781X■
1	1810	2.500-10	3.750	5.875	EY 6.5-4-3451■
1	1810	2.500-10	3.750	5.875	EY 6.5-4-3451-1■
1	1810	2.500-10	3.750	5.875	EY 6.5-4-3551-1X■
1	1810	2.500-10	3.750	5.875	EY 6.5-4-3551X■

Pos	Series	Spline Data	Hub Dia	* to End of Hub	End Fitting Part Number
RTO-11707L					
1	SPL140	2.750-10	3.750	6.570	EY 140-4-81-1
1	SPL140	2.750-10	3.750	6.570	EY 140-4-91-1X
1	SPL170	2.750-10	3.750	5.850	EY 170-4-511-1
1	SPL170	2.750-10	3.750	5.850	EY 170-4-521-1X
1	SPL250	2.750-10	3.750	6.297	EY 250-4-231-1
1	SPL250	2.750-10	3.750	6.297	EY 250-4-241-1X
1	1710	2.750-10	3.750	5.750	EY 6-4-6821
1	1710	2.750-10	3.750	5.750	EY 6-4-6821-1
1	1710	2.750-10	3.750	5.750	EY 6-4-6931-1X
1	1710	2.750-10	3.750	5.750	EY 6-4-6931X
1	1760	2.750-10	3.750	5.969	EY 6.3-4-711
1	1760	2.750-10	3.750	5.969	EY 6.3-4-711-1
1	1760	2.750-10	3.750	5.969	EY 6.3-4-791-1X
1	1760	2.750-10	3.750	5.969	EY 6.3-4-791X
1	1810	2.750-10	3.750	6.062	EY 6.5-4-3491
1	1810	2.750-10	3.750	6.062	EY 6.5-4-3491-1
1	1810	2.750-10	3.750	6.062	EY 6.5-4-3561-1X
1	1810	2.750-10	3.750	6.062	EY 6.5-4-3561X

Pos	Series	Spline Data	Hub Dia	* to End of Hub	End Fitting Part Number
RTO-11708L, RTO-11708LL					
1	1710	2.500-10	3.750	3.625	CF 6-1-5541
1	1710	2.500-10	3.750	3.625	CF 6-1-5651X
1	1810	2.500-10	3.750	3.625	CF 6.5-1-2271
1	1810	2.500-10	3.750	3.625	CF 6.5-1-2351X
1	SPL140	2.500-10	3.750	5.960	EY 140-4-41-1
1	SPL140	2.500-10	3.750	5.960	EY 140-4-51-1X
1	SPL170	2.500-10	3.750	5.750	EY 170-4-471-1■
1	SPL170	2.500-10	3.750	5.750	EY 170-4-481-1X■
1	SPL250	2.500-10	3.750	6.062	EY 250-4-191-1■
1	SPL250	2.500-10	3.750	6.062	EY 250-4-201-1X■
1	1710	2.500-10	3.750	5.625	EY 6-4-6611■
1	1710	2.500-10	3.750	5.625	EY 6-4-6611-1■
1	1710	2.500-10	3.750	5.625	EY 6-4-6921-1X■
1	1710	2.500-10	3.750	5.625	EY 6-4-6921X■
1	1760	2.500-10	3.750	6.000	EY 6.3-4-651■
1	1760	2.500-10	3.750	6.031	EY 6.3-4-651-1■
1	1760	2.500-10	3.750	6.031	EY 6.3-4-781-1X■
1	1760	2.500-10	3.750	6.000	EY 6.3-4-781X■
1	1810	2.500-10	3.750	5.875	EY 6.5-4-3451■
1	1810	2.500-10	3.750	5.875	EY 6.5-4-3451-1■
1	1810	2.500-10	3.750	5.875	EY 6.5-4-3551-1X■
1	1810	2.500-10	3.750	5.875	EY 6.5-4-3551X■

*C/L to End of Hub for EY (End Yoke); Flange Face to End of Hub for CF (Companion Flange)

■ Hub machined for speedometer gear



Important: See Safety Information in General Information Section (J300P-GI)

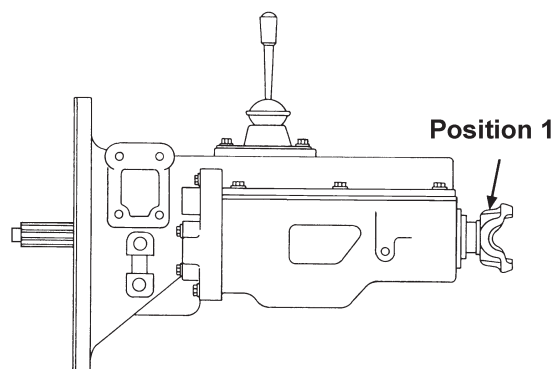

Pos	Series	Spline Data	Hub Dia	* to End of Hub	End Fitting Part Number
RTO-11709M, RTO-11709MLL					
1	SPL170	2.750-10	.000	5.850	EY 170-4-531-1 <i>Hub diameter not ground</i>
1	SPL250	2.750-10	.000	6.310	EY 250-4-251-1
1	1710	2.750-10	3.812	5.750	EY 6-4-7661-1 <i>Hub diameter not ground</i>
1	1760	2.750-10	.000	5.969	EY 6.3-4-1201-1 <i>Hub diameter not ground</i>
1	1810	2.750-10	3.875	6.062	EY 6.5-4-3801-1 <i>Hub diameter not ground</i>

RTO-11909M, RTO-11909MLL					
1	SPL140	2.794-54	.000	6.320	EY 140-4-201-1
1	SPL170	2.794-54	.000	5.600	EY 170-4-561-1 <i>Hub diameter not ground</i>
1	SPL250	2.794-54	.000	5.703	EY 250-4-271-1 <i>Hub diameter not ground</i>
1	1710	2.794-54	.000	5.625	EY 6-4-9231
1	1710	2.794-54	.000	5.625	EY 6-4-9231-1
1	1760	2.794-54	.000	5.625	EY 6.3-4-1681 <i>Hub diameter not ground</i>
1	1760	2.794-54	.000	5.625	EY 6.3-4-1681-1 <i>Hub diameter not ground</i>
1	1810	2.794-54	.000	5.625	EY 6.5-4-4631 <i>Hub diameter not ground</i>
1	1810	2.794-54	.000	5.625	EY 6.5-4-4631-1 <i>Hub diameter not ground</i>

RTO-12509, RTO-12510, RTO-12513, RTO-12515					
1	1810	2.750-10	3.750	4.062	CF 6.5-1-2311
1	1810	2.750-10	3.750	4.062	CF 6.5-1-2361X
1	1810	2.750-10	3.500	4.062	CF 6.5-1-741
1	SPL140	2.750-10	3.750	6.570	EY 140-4-81-1
1	SPL140	2.750-10	3.750	6.570	EY 140-4-91-1X
1	SPL170	2.750-10	3.750	5.850	EY 170-4-511-1
1	SPL170	2.750-10	3.750	5.850	EY 170-4-521-1X
1	SPL250	2.750-10	3.750	6.297	EY 250-4-231-1
1	SPL250	2.750-10	3.750	6.297	EY 250-4-241-1X
1	1710	2.750-10	3.750	5.750	EY 6-4-6821
1	1710	2.750-10	3.750	5.750	EY 6-4-6821-1
1	1710	2.750-10	3.750	5.750	EY 6-4-6931-1X
1	1710	2.750-10	3.750	5.750	EY 6-4-6931X
1	1760	2.750-10	3.750	5.969	EY 6.3-4-711
1	1760	2.750-10	3.750	5.969	EY 6.3-4-711-1
1	1760	2.750-10	3.750	5.969	EY 6.3-4-791-1X
1	1760	2.750-10	3.750	5.969	EY 6.3-4-791X
1	1810	2.750-10	3.750	6.062	EY 6.5-4-3491
1	1810	2.750-10	3.750	6.062	EY 6.5-4-3491-1
1	1810	2.750-10	3.750	6.062	EY 6.5-4-3561-1X
1	1810	2.750-10	3.750	6.062	EY 6.5-4-3561X

Pos	Series	Spline Data	Hub Dia	* to End of Hub	End Fitting Part Number
RTO-12609, RTO-12610					
1	1710	2.500-10	3.750	3.625	CF 6-1-5541
1	1710	2.500-10	3.750	3.625	CF 6-1-5651X
1	1810	2.500-10	3.750	3.625	CF 6.5-1-2271
1	1810	2.500-10	3.750	3.625	CF 6.5-1-2351X
1	SPL140	2.500-10	3.750	5.960	EY 140-4-41-1
1	SPL140	2.500-10	3.750	5.960	EY 140-4-51-1X
1	SPL170	2.500-10	3.750	5.750	EY 170-4-471-1■
1	SPL170	2.500-10	3.750	5.750	EY 170-4-481-1X■
1	SPL250	2.500-10	3.750	6.062	EY 250-4-191-1■
1	SPL250	2.500-10	3.750	6.062	EY 250-4-201-1X■
1	1710	2.500-10	3.750	5.625	EY 6-4-6611■
1	1710	2.500-10	3.750	5.625	EY 6-4-6611-1■
1	1710	2.500-10	3.750	5.625	EY 6-4-6921-1X■
1	1710	2.500-10	3.750	5.625	EY 6-4-6921X■
1	1760	2.500-10	3.750	6.000	EY 6.3-4-651■
1	1760	2.500-10	3.750	6.031	EY 6.3-4-651-1■
1	1760	2.500-10	3.750	6.031	EY 6.3-4-781-1X■
1	1760	2.500-10	3.750	6.000	EY 6.3-4-781X■
1	1810	2.500-10	3.750	5.875	EY 6.5-4-3451■
1	1810	2.500-10	3.750	5.875	EY 6.5-4-3451-1■
1	1810	2.500-10	3.750	5.875	EY 6.5-4-3551-1X■
1	1810	2.500-10	3.750	5.875	EY 6.5-4-3551X■

RTO-13109, RTO-14109					
1	1810	2.750-10	3.750	4.062	CF 6.5-1-2311
1	1810	2.750-10	3.750	4.062	CF 6.5-1-2361X
1	SPL140	2.750-10	3.750	6.570	EY 140-4-81-1
1	SPL140	2.750-10	3.750	6.570	EY 140-4-91-1X
1	SPL170	2.750-10	3.750	5.850	EY 170-4-511-1
1	SPL170	2.750-10	3.750	5.850	EY 170-4-521-1X
1	SPL250	2.750-10	3.750	6.297	EY 250-4-231-1
1	SPL250	2.750-10	3.750	6.297	EY 250-4-241-1X
1	1710	2.750-10	3.750	5.750	EY 6-4-6821
1	1710	2.750-10	3.750	5.750	EY 6-4-6821-1
1	1710	2.750-10	3.750	5.750	EY 6-4-6931-1X
1	1710	2.750-10	3.750	5.750	EY 6-4-6931X
1	1760	2.750-10	3.750	5.969	EY 6.3-4-711
1	1760	2.750-10	3.750	5.969	EY 6.3-4-711-1
1	1760	2.750-10	3.750	5.969	EY 6.3-4-791-1X
1	1760	2.750-10	3.750	5.969	EY 6.3-4-791X
1	1810	2.750-10	3.750	6.062	EY 6.5-4-3491
1	1810	2.750-10	3.750	6.062	EY 6.5-4-3491-1
1	1810	2.750-10	3.750	6.062	EY 6.5-4-3561-1X
1	1810	2.750-10	3.750	6.062	EY 6.5-4-3561X

*C/L to End of Hub for EY (End Yoke); Flange Face to End of Hub for CF (Companion Flange)

■ Hub machined for speedometer gear



Pos	Series	Spline Data	Hub Dia	* to End of Hub	End Fitting Part Number
RTO-14209, RTO-14209MLL, RTO-14210					
1	SPL140	2.794-54	.000	6.320	EY 140-4-201-1
1	SPL170	2.794-54	.000	5.600	EY 170-4-561-1 <i>Hub diameter not ground</i>
1	SPL250	2.794-54	.000	5.703	EY 250-4-271-1 <i>Hub diameter not ground</i>
1	1710	2.794-54	.000	5.625	EY 6-4-9231
1	1710	2.794-54	.000	5.625	EY 6-4-9231-1
1	1760	2.794-54	.000	5.625	EY 6.3-4-1681 <i>Hub diameter not ground</i>
1	1760	2.794-54	.000	5.625	EY 6.3-4-1681-1 <i>Hub diameter not ground</i>
1	1810	2.794-54	.000	5.625	EY 6.5-4-4631 <i>Hub diameter not ground</i>
1	1810	2.794-54	.000	5.625	EY 6.5-4-4631-1 <i>Hub diameter not ground</i>
RTO-14608L, RTO-14608LL, RTO-14609, RTO-14610, RTO-14613, RTO-14708L, RTO-14708LL					
1	1810	2.750-10	3.750	4.062	CF 6.5-1-2311
1	1810	2.750-10	3.750	4.062	CF 6.5-1-2361X
1	SPL140	2.750-10	3.750	6.570	EY 140-4-81-1
1	SPL140	2.750-10	3.750	6.570	EY 140-4-91-1X
1	SPL170	2.750-10	3.750	5.850	EY 170-4-511-1
1	SPL170	2.750-10	3.750	5.850	EY 170-4-521-1X
1	SPL250	2.750-10	3.750	6.297	EY 250-4-231-1
1	SPL250	2.750-10	3.750	6.297	EY 250-4-241-1X
1	1710	2.750-10	3.750	5.750	EY 6-4-6821
1	1710	2.750-10	3.750	5.750	EY 6-4-6821-1
1	1710	2.750-10	3.750	5.750	EY 6-4-6931-1X
1	1710	2.750-10	3.750	5.750	EY 6-4-6931X
1	1760	2.750-10	3.750	5.969	EY 6.3-4-711
1	1760	2.750-10	3.750	5.969	EY 6.3-4-711-1
1	1760	2.750-10	3.750	5.969	EY 6.3-4-791-1X
1	1760	2.750-10	3.750	5.969	EY 6.3-4-791X
1	1810	2.750-10	3.750	6.062	EY 6.5-4-3491
1	1810	2.750-10	3.750	6.062	EY 6.5-4-3491-1
1	1810	2.750-10	3.750	6.062	EY 6.5-4-3561-1X
1	1810	2.750-10	3.750	6.062	EY 6.5-4-3561X
RTO-14709M, RTO-14709MLL					
1	SPL170	2.750-10	.000	5.850	EY 170-4-531-1 <i>Hub diameter not ground</i>
1	SPL250	2.750-10	.000	6.310	EY 250-4-251-1
1	1710	2.750-10	3.812	5.750	EY 6-4-7661-1 <i>Hub diameter not ground</i>
1	1760	2.750-10	.000	5.969	EY 6.3-4-1201-1 <i>Hub diameter not ground</i>
1	1810	2.750-10	3.875	6.062	EY 6.5-4-3801-1 <i>Hub diameter not ground</i>
RTO-14908L, RTO-14908LL, RTO-14909M, RTO-14909MLL, RTO-15210					
1	SPL140	2.794-54	.000	6.320	EY 140-4-201-1
1	SPL170	2.794-54	.000	5.600	EY 170-4-561-1 <i>Hub diameter not ground</i>
1	SPL250	2.794-54	.000	5.703	EY 250-4-271-1 <i>Hub diameter not ground</i>
1	1710	2.794-54	.000	5.625	EY 6-4-9231
1	1710	2.794-54	.000	5.625	EY 6-4-9231-1
1	1760	2.794-54	.000	5.625	EY 6.3-4-1681 <i>Hub diameter not ground</i>
1	1760	2.794-54	.000	5.625	EY 6.3-4-1681-1 <i>Hub diameter not ground</i>
1	1810	2.794-54	.000	5.625	EY 6.5-4-4631 <i>Hub diameter not ground</i>
1	1810	2.794-54	.000	5.625	EY 6.5-4-4631-1 <i>Hub diameter not ground</i>

Pos	Series	Spline Data	Hub Dia	* to End of Hub	End Fitting Part Number
RTO-15613, RTO-15618, RTO-15813, RTO-16109					
1	1810	2.750-10	3.750	4.062	CF 6.5-1-2311
1	1810	2.750-10	3.750	4.062	CF 6.5-1-2361X
1	SPL140	2.750-10	3.750	6.570	EY 140-4-81-1
1	SPL140	2.750-10	3.750	6.570	EY 140-4-91-1X
1	SPL170	2.750-10	3.750	5.850	EY 170-4-511-1
1	SPL170	2.750-10	3.750	5.850	EY 170-4-521-1X
1	SPL250	2.750-10	3.750	6.297	EY 250-4-231-1
1	SPL250	2.750-10	3.750	6.297	EY 250-4-241-1X
1	1710	2.750-10	3.750	5.750	EY 6-4-6821
1	1710	2.750-10	3.750	5.750	EY 6-4-6821-1
1	1710	2.750-10	3.750	5.750	EY 6-4-6931-1X
1	1710	2.750-10	3.750	5.750	EY 6-4-6931X
1	1760	2.750-10	3.750	5.969	EY 6.3-4-711
1	1760	2.750-10	3.750	5.969	EY 6.3-4-711-1
1	1760	2.750-10	3.750	5.969	EY 6.3-4-791-1X
1	1760	2.750-10	3.750	5.969	EY 6.3-4-791X
1	1810	2.750-10	3.750	6.062	EY 6.5-4-3491
1	1810	2.750-10	3.750	6.062	EY 6.5-4-3491-1
1	1810	2.750-10	3.750	6.062	EY 6.5-4-3561-1X
1	1810	2.750-10	3.750	6.062	EY 6.5-4-3561X
RTO-16210, RTO-16908L, RTO-16908LL, RTO-16910C					
1	SPL140	2.794-54	.000	6.320	EY 140-4-201-1
1	SPL170	2.794-54	.000	5.600	EY 170-4-561-1 <i>Hub diameter not ground</i>
1	SPL250	2.794-54	.000	5.703	EY 250-4-271-1 <i>Hub diameter not ground</i>
1	1710	2.794-54	.000	5.625	EY 6-4-9231
1	1710	2.794-54	.000	5.625	EY 6-4-9231-1
1	1760	2.794-54	.000	5.625	EY 6.3-4-1681 <i>Hub diameter not ground</i>
1	1760	2.794-54	.000	5.625	EY 6.3-4-1681-1 <i>Hub diameter not ground</i>
1	1810	2.794-54	.000	5.625	EY 6.5-4-4631 <i>Hub diameter not ground</i>
1	1810	2.794-54	.000	5.625	EY 6.5-4-4631-1 <i>Hub diameter not ground</i>
RTOF-11607					
1	1810	2.750-10	3.750	4.062	CF 6.5-1-2311
1	1810	2.750-10	3.750	4.062	CF 6.5-1-2361X
1	SPL140	2.750-10	3.750	6.570	EY 140-4-81-1
1	SPL140	2.750-10	3.750	6.570	EY 140-4-91-1X
1	SPL170	2.750-10	3.750	5.850	EY 170-4-511-1
1	SPL170	2.750-10	3.750	5.850	EY 170-4-521-1X
1	SPL250	2.750-10	3.750	6.297	EY 250-4-231-1
1	SPL250	2.750-10	3.750	6.297	EY 250-4-241-1X
1	1710	2.750-10	3.750	5.750	EY 6-4-6821
1	1710	2.750-10	3.750	5.750	EY 6-4-6821-1
1	1710	2.750-10	3.750	5.750	EY 6-4-6931-1X
1	1710	2.750-10	3.750	5.750	EY 6-4-6931X
1	1760	2.750-10	3.750	5.969	EY 6.3-4-711
1	1760	2.750-10	3.750	5.969	EY 6.3-4-711-1
1	1760	2.750-10	3.750	5.969	EY 6.3-4-791-1X
1	1760	2.750-10	3.750	5.969	EY 6.3-4-791X
1	1810	2.750-10	3.750	6.062	EY 6.5-4-3491
1	1810	2.750-10	3.750	6.062	EY 6.5-4-3491-1
1	1810	2.750-10	3.750	6.062	EY 6.5-4-3561-1X
1	1810	2.750-10	3.750	6.062	EY 6.5-4-3561X

*C/L to End of Hub for EY (End Yoke); Flange Face to End of Hub for CF (Companion Flange)

■ Hub machined for speedometer gear



Important: See Safety Information in General Information Section (J300P-GI)

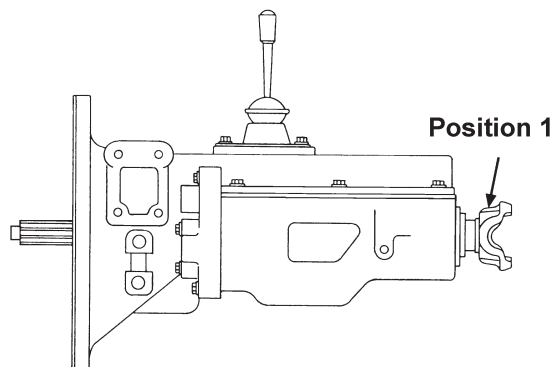

Pos	Series	Spline Data	Hub Dia	* to End of Hub	End Fitting Part Number
-----	--------	-------------	---------	-----------------	-------------------------

RTOF-11707

1	SPL140	2.750-10	3.750	6.570	EY 140-4-81-1
1	SPL140	2.750-10	3.750	6.570	EY 140-4-91-1X
1	SPL170	2.750-10	3.750	5.850	EY 170-4-511-1
1	SPL170	2.750-10	3.750	5.850	EY 170-4-521-1X
1	SPL250	2.750-10	3.750	6.297	EY 250-4-231-1
1	SPL250	2.750-10	3.750	6.297	EY 250-4-241-1X
1	1710	2.750-10	3.750	5.750	EY 6-4-6821
1	1710	2.750-10	3.750	5.750	EY 6-4-6821-1
1	1710	2.750-10	3.750	5.750	EY 6-4-6931-1X
1	1710	2.750-10	3.750	5.750	EY 6-4-6931X
1	1760	2.750-10	3.750	5.969	EY 6.3-4-711
1	1760	2.750-10	3.750	5.969	EY 6.3-4-711-1
1	1760	2.750-10	3.750	5.969	EY 6.3-4-791-1X
1	1760	2.750-10	3.750	5.969	EY 6.3-4-791X
1	1810	2.750-10	3.750	6.062	EY 6.5-4-3491
1	1810	2.750-10	3.750	6.062	EY 6.5-4-3491-1
1	1810	2.750-10	3.750	6.062	EY 6.5-4-3561-1X
1	1810	2.750-10	3.750	6.062	EY 6.5-4-3561X

RTOO-913

1	SPL140	2.500-10	3.750	5.960	EY 140-4-41-1
1	SPL140	2.500-10	3.750	5.960	EY 140-4-51-1X
1	SPL170	2.500-10	3.750	5.750	EY 170-4-471-1■
1	SPL170	2.500-10	3.750	5.750	EY 170-4-481-1X■
1	SPL250	2.500-10	3.750	6.062	EY 250-4-191-1■
1	SPL250	2.500-10	3.750	6.062	EY 250-4-201-1X■

RTOO-958LL, RTOO-9513

1	1710	2.500-10	3.750	3.625	CF 6-1-5541
1	1710	2.500-10	3.750	3.625	CF 6-1-5651X
1	1810	2.500-10	3.750	3.625	CF 6.5-1-2351X
1	SPL140	2.500-10	3.750	5.960	EY 140-4-41-1
1	SPL140	2.500-10	3.750	5.960	EY 140-4-51-1X
1	SPL170	2.500-10	3.750	5.750	EY 170-4-471-1■
1	SPL170	2.500-10	3.750	5.750	EY 170-4-481-1X■
1	SPL250	2.500-10	3.750	6.062	EY 250-4-191-1■
1	SPL250	2.500-10	3.750	6.062	EY 250-4-201-1X■
1	1710	2.500-10	3.750	5.625	EY 6-4-6611■
1	1710	2.500-10	3.750	5.625	EY 6-4-6611-1■
1	1710	2.500-10	3.750	5.625	EY 6-4-6921-1X■
1	1710	2.500-10	3.750	5.625	EY 6-4-6921X■
1	1760	2.500-10	3.750	6.000	EY 6.3-4-651■
1	1760	2.500-10	3.750	6.031	EY 6.3-4-651-1■
1	1760	2.500-10	3.750	6.031	EY 6.3-4-781-1X■

Pos	Series	Spline Data	Hub Dia	* to End of Hub	End Fitting Part Number
-----	--------	-------------	---------	-----------------	-------------------------

RTOO-958LL, RTOO-9513 (Continued)

1	1760	2.500-10	3.750	6.000	EY 6.3-4-781X■
1	1810	2.500-10	3.750	5.875	EY 6.5-4-3451■
1	1810	2.500-10	3.750	5.875	EY 6.5-4-3451-1■
1	1810	2.500-10	3.750	5.875	EY 6.5-4-3551-1X■
1	1810	2.500-10	3.750	5.875	EY 6.5-4-3551X■

RTOO-11613

1	1710	2.500-10	3.750	3.625	CF 6-1-5541
1	1710	2.500-10	3.750	3.625	CF 6-1-5651X
1	1810	2.500-10	3.750	3.625	CF 6.5-1-2271
1	1810	2.500-10	3.750	3.625	CF 6.5-1-2351X
1	SPL170	2.500-10	3.750	5.750	EY 170-4-471-1■
1	SPL170	2.500-10	3.750	5.750	EY 170-4-481-1X■
1	SPL250	2.500-10	3.750	6.062	EY 250-4-191-1■
1	SPL250	2.500-10	3.750	6.062	EY 250-4-201-1X■
1	1710	2.500-10	3.750	5.625	EY 6-4-6611■
1	1710	2.500-10	3.750	5.625	EY 6-4-6611-1■
1	1710	2.500-10	3.750	5.625	EY 6-4-6921-1X■
1	1710	2.500-10	3.750	5.625	EY 6-4-6921X■
1	1760	2.500-10	3.750	6.000	EY 6.3-4-651■
1	1760	2.500-10	3.750	6.031	EY 6.3-4-651-1■
1	1760	2.500-10	3.750	6.031	EY 6.3-4-781-1X■
1	1810	2.500-10	3.750	5.875	EY 6.5-4-3451■
1	1810	2.500-10	3.750	5.875	EY 6.5-4-3451-1■
1	1810	2.500-10	3.750	5.875	EY 6.5-4-3551-1X■
1	1810	2.500-10	3.750	5.875	EY 6.5-4-3551X■

RTOO-14613

1	1810	2.750-10	3.750	4.062	CF 6.5-1-2311
1	1810	2.750-10	3.750	4.062	CF 6.5-1-2361X
1	SPL140	2.750-10	3.750	6.570	EY 140-4-81-1
1	SPL140	2.750-10	3.750	6.570	EY 140-4-91-1X
1	SPL170	2.750-10	3.750	5.850	EY 170-4-511-1
1	SPL170	2.750-10	3.750	5.850	EY 170-4-521-1X
1	SPL250	2.750-10	3.750	6.297	EY 250-4-231-1
1	SPL250	2.750-10	3.750	6.297	EY 250-4-241-1X
1	1710	2.750-10	3.750	5.750	EY 6-4-6821
1	1710	2.750-10	3.750	5.750	EY 6-4-6821-1
1	1710	2.750-10	3.750	5.750	EY 6-4-6931-1X
1	1710	2.750-10	3.750	5.750	EY 6-4-6931X
1	1760	2.750-10	3.750	5.969	EY 6.3-4-711
1	1760	2.750-10	3.750	5.969	EY 6.3-4-711-1
1	1760	2.750-10	3.750	5.969	EY 6.3-4-791-1X

*C/L to End of Hub for EY (End Yoke); Flange Face to End of Hub for CF (Companion Flange)

■ Hub machined for speedometer gear



Pos	Series	Spline Data	Hub Dia	* to End of Hub	End Fitting Part Number
-----	--------	-------------	---------	-----------------	-------------------------

RT00-14613 (Continued)

1	1760	2.750-10	3.750	5.969	EY 6.3-4-791X
1	1810	2.750-10	3.750	6.062	EY 6.5-4-3491
1	1810	2.750-10	3.750	6.062	EY 6.5-4-3491-1
1	1810	2.750-10	3.750	6.062	EY 6.5-4-3561-1X
1	1810	2.750-10	3.750	6.062	EY 6.5-4-3561X

RTT-12609

1	1710	2.500-10	3.750	3.625	CF 6-1-5541
1	1710	2.500-10	3.750	3.625	CF 6-1-5651X
1	1810	2.500-10	3.750	3.625	CF 6.5-1-2351X
1	SPL140	2.500-10	3.750	5.960	EY 140-4-41-1
1	SPL140	2.500-10	3.750	5.960	EY 140-4-51-1X
1	SPL170	2.500-10	3.750	5.750	EY 170-4-471-1■
1	SPL170	2.500-10	3.750	5.750	EY 170-4-481-1X■
1	SPL250	2.500-10	3.750	6.062	EY 250-4-191-1■
1	SPL250	2.500-10	3.750	6.062	EY 250-4-201-1X■
1	1710	2.500-10	3.750	5.625	EY 6-4-6611■
1	1710	2.500-10	3.750	5.625	EY 6-4-6611-1■
1	1710	2.500-10	3.750	5.625	EY 6-4-6921-1X■
1	1710	2.500-10	3.750	5.625	EY 6-4-6921X■
1	1760	2.500-10	3.750	6.000	EY 6.3-4-651■
1	1760	2.500-10	3.750	6.031	EY 6.3-4-651-1■
1	1760	2.500-10	3.750	6.031	EY 6.3-4-781-1X■
1	1760	2.500-10	3.750	6.000	EY 6.3-4-781X■
1	1810	2.500-10	3.750	5.875	EY 6.5-4-3451■
1	1810	2.500-10	3.750	5.875	EY 6.5-4-3451-1■
1	1810	2.500-10	3.750	5.875	EY 6.5-4-3551-1X■
1	1810	2.500-10	3.750	5.875	EY 6.5-4-3551X■

RTX-7609

1	1710	2.544-49	3.755	5.625	EY 6-4-7041-1X■
1	1710	2.544-49	3.755	5.625	EY 6-4-7041X■
1	1710	2.544-49	3.755	5.625	EY 6-4-7051■
1	1760	2.544-49	3.750	6.031	EY 6.3-4-771-1X■
1	1760	2.544-49	3.750	6.031	EY 6.3-4-771X■
1	1760	2.544-49	3.750	6.031	EY 6.3-4-811■
1	1760	2.544-49	3.750	6.031	EY 6.3-4-811-1■
1	1810	2.544-49	3.750	5.875	EY 6.5-4-3611■
1	1810	2.544-49	3.750	5.875	EY 6.5-4-3611-1■
1	1810	2.544-49	3.750	5.875	EY 6.5-4-3621-1X■
1	1810	2.544-49	3.750	5.875	EY 6.5-4-3621X■

RTX-11609, RTX-12609, RTX-13710

1	1710	2.500-10	3.750	3.625	CF 6-1-5541
1	1710	2.500-10	3.750	3.625	CF 6-1-5651X
1	1810	2.500-10	3.750	3.625	CF 6.5-1-2271
1	1810	2.500-10	3.750	3.625	CF 6.5-1-2351X
1	SPL140	2.500-10	3.750	5.960	EY 140-4-41-1
1	SPL140	2.500-10	3.750	5.960	EY 140-4-51-1X
1	SPL170	2.500-10	3.750	5.750	EY 170-4-471-1■
1	SPL170	2.500-10	3.750	5.750	EY 170-4-481-1X■
1	SPL250	2.500-10	3.750	6.062	EY 250-4-191-1■
1	SPL250	2.500-10	3.750	6.062	EY 250-4-201-1X■
1	1710	2.500-10	3.750	5.625	EY 6-4-6611■
1	1710	2.500-10	3.750	5.625	EY 6-4-6611-1■
1	1710	2.500-10	3.750	5.625	EY 6-4-6921-1X■
1	1710	2.500-10	3.750	5.625	EY 6-4-6921X■
1	1760	2.500-10	3.750	6.000	EY 6.3-4-651■
1	1760	2.500-10	3.750	6.031	EY 6.3-4-651-1■
1	1760	2.500-10	3.750	6.031	EY 6.3-4-781-1X■

Pos	Series	Spline Data	Hub Dia	* to End of Hub	End Fitting Part Number
-----	--------	-------------	---------	-----------------	-------------------------

RTX-11609, RTX-12609, RTX-13710 (Continued)

1	1760	2.500-10	3.750	6.000	EY 6.3-4-781X■
1	1810	2.500-10	3.750	5.875	EY 6.5-4-3451■
1	1810	2.500-10	3.750	5.875	EY 6.5-4-3451-1■
1	1810	2.500-10	3.750	5.875	EY 6.5-4-3551-1X■
1	1810	2.500-10	3.750	5.875	EY 6.5-4-3551X■

RTX-14609B, RTX-14710B, RTX-15710, RTX-16709, RTX-16709H, RTX-16710

1	1810	2.750-10	3.750	4.062	CF 6.5-1-2311
1	1810	2.750-10	3.750	4.062	CF 6.5-1-2361X
1	SPL140	2.750-10	3.750	6.570	EY 140-4-81-1
1	SPL140	2.750-10	3.750	6.570	EY 140-4-91-1X
1	SPL170	2.750-10	3.750	5.850	EY 170-4-511-1
1	SPL170	2.750-10	3.750	5.850	EY 170-4-521-1X
1	SPL250	2.750-10	3.750	6.297	EY 250-4-231-1
1	SPL250	2.750-10	3.750	6.297	EY 250-4-241-1X
1	1710	2.750-10	3.750	5.750	EY 6-4-6821
1	1710	2.750-10	3.750	5.750	EY 6-4-6821-1
1	1710	2.750-10	3.750	5.750	EY 6-4-6931-1X
1	1710	2.750-10	3.750	5.750	EY 6-4-6931X
1	1760	2.750-10	3.750	5.969	EY 6.3-4-711
1	1760	2.750-10	3.750	5.969	EY 6.3-4-711-1
1	1760	2.750-10	3.750	5.969	EY 6.3-4-791-1X
1	1760	2.750-10	3.750	5.969	EY 6.3-4-791X
1	1810	2.750-10	3.750	6.062	EY 6.5-4-3491
1	1810	2.750-10	3.750	6.062	EY 6.5-4-3491-1
1	1810	2.750-10	3.750	6.062	EY 6.5-4-3561-1X
1	1810	2.750-10	3.750	6.062	EY 6.5-4-3561X

T-904

1	1610	2.250-10	3.500	3.625	CF 5-1-6331
1	1710	2.250-10	3.500	3.688	CF 6-1-951
1	1810	2.250-10	3.500	3.688	CF 6.5-1-151
1	SPL90	2.250-10	3.500	5.219	EY 90-4-151-1X
1	SPL90	2.250-10	3.750	5.219	EY 90-4-171-1X
<i>Change seal to service older trans.</i>					
1	1550	2.250-10	3.500	5.125	EY 4-4-3501-1
1	1610	2.250-10	3.500	5.750	EY 5-4-4961
1	1610	2.250-10	3.500	5.750	EY 5-4-4961-1
1	1610	2.250-10	3.750	5.750	EY 5-4-7391-1X
1	1710	2.250-10	3.500	5.250	EY 6-4-6861
1	1710	2.250-10	3.500	5.250	EY 6-4-6861-1
1	1710	2.250-10	3.500	5.250	EY 6-4-6901-1X
1	1710	2.250-10	3.750	5.250	EY 6-4-7381-1X
<i>Change seal to service older trans.</i>					
1	1760	2.250-10	3.750	5.625	EY 6.3-4-1101-1X
<i>Change seal to service older trans.</i>					
1	1760	2.250-10	3.500	5.656	EY 6.3-4-701-1
1	1810	2.250-10	3.500	5.844	EY 6.5-4-2021

T-905

1	1610	2.250-10	3.500	3.625	CF 5-1-6331
1	1810	2.250-10	3.500	3.688	CF 6.5-1-151
1	SPL170	2.250-10	3.500	5.750	EY 170-4-451-1
1	SPL170	2.250-10	3.500	5.750	EY 170-4-461-1X
1	SPL90	2.250-10	3.500	5.219	EY 90-4-151-1X
1	SPL90	2.250-10	3.500	5.219	EY 90-4-401-1
1	1550	2.250-10	3.500	5.125	EY 4-4-3501-1
1	1610	2.250-10	3.500	5.750	EY 5-4-4961
1	1610	2.250-10	3.500	5.750	EY 5-4-4961-1

Continued on next page

*C/L to End of Hub for EY (End Yoke); Flange Face to End of Hub for CF (Companion Flange)

■ Hub machined for speedometer gear



Important: See Safety Information in General Information Section (J300P-GI)

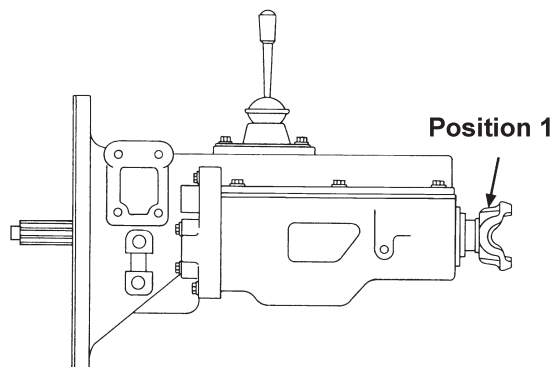

Pos	Series	Spline Data	Hub Dia	* to End of Hub	End Fitting Part Number
-----	--------	-------------	---------	-----------------	-------------------------

T-905 (Continued)

1	1710	2.250-10	3.500	5.250	EY 6-4-6861
1	1710	2.250-10	3.500	5.250	EY 6-4-6861-1
1	1710	2.250-10	3.500	5.250	EY 6-4-6901-1X
1	1810	2.250-10	3.500	5.844	EY 6.5-4-2021

T-955-AL, T-955-ALL

1	1710	2.500-10	3.750	3.625	CF 6-1-5541
1	1710	2.500-10	3.750	3.625	CF 6-1-5651X
1	1810	2.500-10	3.750	3.625	CF 6.5-1-2271
1	1810	2.500-10	3.750	3.625	CF 6.5-1-2351X
1	SPL140	2.500-10	3.750	5.960	EY 140-4-41-1
1	SPL140	2.500-10	3.750	5.960	EY 140-4-51-1X
1	SPL170	2.500-10	3.750	5.750	EY 170-4-471-1■
1	SPL170	2.500-10	3.750	5.750	EY 170-4-481-1X■
1	SPL250	2.500-10	3.750	6.062	EY 250-4-191-1■
1	SPL250	2.500-10	3.750	6.062	EY 250-4-201-1X■
1	1710	2.500-10	3.750	5.625	EY 6-4-6611■
1	1710	2.500-10	3.750	5.625	EY 6-4-6611-1■
1	1710	2.500-10	3.750	5.625	EY 6-4-6921-1X■
1	1710	2.500-10	3.750	5.625	EY 6-4-6921X■
1	1760	2.500-10	3.750	6.000	EY 6.3-4-651■
1	1760	2.500-10	3.750	6.031	EY 6.3-4-651-1■
1	1760	2.500-10	3.750	6.031	EY 6.3-4-781-1X■
1	1760	2.500-10	3.750	6.000	EY 6.3-4-781X■
1	1810	2.500-10	3.750	5.875	EY 6.5-4-3451■
1	1810	2.500-10	3.750	5.875	EY 6.5-4-3451-1■
1	1810	2.500-10	3.750	5.875	EY 6.5-4-3551-1X■
1	1810	2.500-10	3.750	5.875	EY 6.5-4-3551X■

T-955-GL

1	1710	2.500-10	3.750	3.625	CF 6-1-5541
1	1710	2.500-10	3.750	3.625	CF 6-1-5651X
1	1810	2.500-10	3.750	3.625	CF 6.5-1-2271
1	1810	2.500-10	3.750	3.625	CF 6.5-1-2351X
1	SPL170	2.500-10	3.750	5.750	EY 170-4-471-1■
1	SPL170	2.500-10	3.750	5.750	EY 170-4-481-1X■
1	SPL250	2.500-10	3.750	6.062	EY 250-4-191-1■
1	SPL250	2.500-10	3.750	6.062	EY 250-4-201-1X■
1	1710	2.500-10	3.750	5.625	EY 6-4-6611■
1	1710	2.500-10	3.750	5.625	EY 6-4-6611-1■
1	1710	2.500-10	3.750	5.625	EY 6-4-6921-1X■
1	1710	2.500-10	3.750	5.625	EY 6-4-6921X■
1	1760	2.500-10	3.750	6.000	EY 6.3-4-651■
1	1760	2.500-10	3.750	6.031	EY 6.3-4-651-1■

Pos	Series	Spline Data	Hub Dia	* to End of Hub	End Fitting Part Number
-----	--------	-------------	---------	-----------------	-------------------------

T-955-GL (Continued)

1	1760	2.500-10	3.750	6.031	EY 6.3-4-781-1X■
1	1760	2.500-10	3.750	6.000	EY 6.3-4-781X■
1	1810	2.500-10	3.750	5.875	EY 6.5-4-3451■
1	1810	2.500-10	3.750	5.875	EY 6.5-4-3451-1■
1	1810	2.500-10	3.750	5.875	EY 6.5-4-3551-1X■
1	1810	2.500-10	3.750	5.875	EY 6.5-4-3551X■

T-1056A, T-1056AA

1	1710	2.500-10	3.750	3.625	CF 6-1-5541
1	1710	2.500-10	3.750	3.625	CF 6-1-5651X
1	1810	2.500-10	3.750	3.625	CF 6.5-1-2271
1	1810	2.500-10	3.750	3.625	CF 6.5-1-2351X
1	SPL140	2.500-10	3.750	5.960	EY 140-4-41-1
1	SPL140	2.500-10	3.750	5.960	EY 140-4-51-1X
1	SPL170	2.500-10	3.750	5.750	EY 170-4-471-1■
1	SPL170	2.500-10	3.750	5.750	EY 170-4-481-1X■
1	SPL250	2.500-10	3.750	6.062	EY 250-4-191-1■
1	SPL250	2.500-10	3.750	6.062	EY 250-4-201-1X■
1	1710	2.500-10	3.750	5.625	EY 6-4-6611■
1	1710	2.500-10	3.750	5.625	EY 6-4-6611-1■
1	1710	2.500-10	3.750	5.625	EY 6-4-6921-1X■
1	1710	2.500-10	3.750	5.625	EY 6-4-6921X■
1	1760	2.500-10	3.750	6.000	EY 6.3-4-651■
1	1760	2.500-10	3.750	6.031	EY 6.3-4-651-1■
1	1760	2.500-10	3.750	6.031	EY 6.3-4-781-1X■
1	1760	2.500-10	3.750	6.000	EY 6.3-4-781X■
1	1810	2.500-10	3.750	5.875	EY 6.5-4-3451■
1	1810	2.500-10	3.750	5.875	EY 6.5-4-3451-1■
1	1810	2.500-10	3.750	5.875	EY 6.5-4-3551-1X■
1	1810	2.500-10	3.750	5.875	EY 6.5-4-3551X■

T-8607

1	1610	2.343-45	3.750	5.750	EY 5-4-7641-1
1	1610	2.343-45	3.750	5.750	EY 5-4-7651-1X
1	1710	2.343-45	3.750	5.250	EY 6-4-7251
1	1710	2.343-45	3.750	5.250	EY 6-4-7251-1
1	1710	2.343-45	3.750	5.250	EY 6-4-7271-1X
1	1710	2.343-45	3.750	5.250	EY 6-4-7271X
1	1760	2.343-45	3.750	5.656	EY 6.3-4-841-1
1	1760	2.343-45	3.750	5.656	EY 6.3-4-901-1X

T-11605

1	1610	2.250-10	3.500	3.625	CF 5-1-6331
1	1810	2.250-10	3.500	3.688	CF 6.5-1-151
1	SPL140	2.250-10	3.500	6.000	EY 140-4-1091-1

*C/L to End of Hub for EY (End Yoke); Flange Face to End of Hub for CF (Companion Flange)

■ Hub machined for speedometer gear



Pos	Series	Spline Data	Hub Dia	* to End of Hub	End Fitting Part Number
T-11605 (Continued)					
1	SPL140	2.250-10	3.500	6.000	EY 140-4-1101-1X
1	SPL170	2.250-10	3.500	5.750	EY 170-4-451-1
1	SPL170	2.250-10	3.500	5.750	EY 170-4-461-1X
1	SPL90	2.250-10	3.500	5.219	EY 90-4-151-1X
1	SPL90	2.250-10	3.750	5.219	EY 90-4-161-1
1	SPL90	2.250-10	3.750	5.219	EY 90-4-171-1X
1	SPL90	2.250-10	3.500	5.219	EY 90-4-401-1
1	1550	2.250-10	3.500	5.125	EY 4-4-3501-1
1	1610	2.250-10	3.500	5.750	EY 5-4-4961
1	1610	2.250-10	3.500	5.750	EY 5-4-4961-1
1	1610	2.250-10	3.750	5.750	EY 5-4-7381-1
1	1610	2.250-10	3.750	5.750	EY 5-4-7391-1X
1	1710	2.250-10	3.500	5.250	EY 6-4-6861
1	1710	2.250-10	3.500	5.250	EY 6-4-6861-1
1	1710	2.250-10	3.500	5.250	EY 6-4-6901-1X
1	1710	2.250-10	3.750	5.250	EY 6-4-7371-1
1	1710	2.250-10	3.750	5.250	EY 6-4-7381-1X
1	1760	2.250-10	3.750	5.625	EY 6.3-4-1091-1
1	1760	2.250-10	3.750	5.625	EY 6.3-4-1101-1X
1	1760	2.250-10	3.500	5.656	EY 6.3-4-701-1
1	1810	2.250-10	3.500	5.844	EY 6.5-4-2021

T-11606					
1	1710	2.500-10	3.750	3.625	CF 6-1-5541
1	1710	2.500-10	3.750	3.625	CF 6-1-5651X
1	SPL140	2.500-10	3.750	5.960	EY 140-4-41-1
1	SPL140	2.500-10	3.750	5.960	EY 140-4-51-1X
1	SPL170	2.500-10	3.750	5.750	EY 170-4-471-1■
1	SPL170	2.500-10	3.750	5.750	EY 170-4-481-1X■
1	SPL250	2.500-10	3.750	6.062	EY 250-4-191-1■
1	SPL250	2.500-10	3.750	6.062	EY 250-4-201-1X■
1	1710	2.500-10	3.750	5.625	EY 6-4-6611■
1	1710	2.500-10	3.750	5.625	EY 6-4-6611-1■
1	1710	2.500-10	3.750	5.625	EY 6-4-6921-1X■
1	1710	2.500-10	3.750	5.625	EY 6-4-6921X■
1	1760	2.500-10	3.750	6.000	EY 6.3-4-651■
1	1760	2.500-10	3.750	6.031	EY 6.3-4-651-1■
1	1760	2.500-10	3.750	6.031	EY 6.3-4-781-1X■
1	1760	2.500-10	3.750	6.000	EY 6.3-4-781X■
1	1810	2.500-10	3.750	5.875	EY 6.5-4-3451■
1	1810	2.500-10	3.750	5.875	EY 6.5-4-3451-1■
1	1810	2.500-10	3.750	5.875	EY 6.5-4-3551-1X■
1	1810	2.500-10	3.750	5.875	EY 6.5-4-3551X■

T-11607					
1	1710	2.500-10	3.750	3.625	CF 6-1-5541
1	1710	2.500-10	3.750	3.625	CF 6-1-5651X
1	1810	2.500-10	3.750	3.625	CF 6.5-1-2271
1	1810	2.500-10	3.750	3.625	CF 6.5-1-2351X
1	SPL140	2.500-10	3.750	5.960	EY 140-4-41-1
1	SPL140	2.500-10	3.750	5.960	EY 140-4-51-1X
1	SPL170	2.500-10	3.750	5.750	EY 170-4-471-1■
1	SPL170	2.500-10	3.750	5.750	EY 170-4-481-1X■
1	SPL250	2.500-10	3.750	6.062	EY 250-4-191-1■
1	SPL250	2.500-10	3.750	6.062	EY 250-4-201-1X■
1	1710	2.500-10	3.750	5.625	EY 6-4-6611■
1	1710	2.500-10	3.750	5.625	EY 6-4-6611-1■
1	1710	2.500-10	3.750	5.625	EY 6-4-6921-1X■
1	1710	2.500-10	3.750	5.625	EY 6-4-6921X■

Pos	Series	Spline Data	Hub Dia	* to End of Hub	End Fitting Part Number
T-11607 (Continued)					
1	1760	2.500-10	3.750	6.000	EY 6.3-4-651■
1	1760	2.500-10	3.750	6.031	EY 6.3-4-651-1■
1	1760	2.500-10	3.750	6.031	EY 6.3-4-781-1X■
1	1760	2.500-10	3.750	6.000	EY 6.3-4-781X■
1	1810	2.500-10	3.750	5.875	EY 6.5-4-3451■
1	1810	2.500-10	3.750	5.875	EY 6.5-4-3451-1■
1	1810	2.500-10	3.750	5.875	EY 6.5-4-3551-1X■
1	1810	2.500-10	3.750	5.875	EY 6.5-4-3551X■

T-11609					
1	1610	2.250-10	3.750	5.750	EY 5-4-7391-1X

T-11610					
1	1710	2.500-10	3.750	3.625	CF 6-1-5541
1	1710	2.500-10	3.750	3.625	CF 6-1-5651X
1	1810	2.500-10	3.750	3.625	CF 6.5-1-2271
1	1810	2.500-10	3.750	3.625	CF 6.5-1-2351X
1	SPL140	2.500-10	3.750	5.960	EY 140-4-41-1
1	SPL140	2.500-10	3.750	5.960	EY 140-4-51-1X
1	SPL170	2.500-10	3.750	5.750	EY 170-4-471-1■
1	SPL170	2.500-10	3.750	5.750	EY 170-4-481-1X■
1	SPL250	2.500-10	3.750	6.062	EY 250-4-191-1■
1	SPL250	2.500-10	3.750	6.062	EY 250-4-201-1X■
1	1610	2.500-10	3.750	6.125	EY 5-4-4971■
1	1710	2.500-10	3.750	5.625	EY 6-4-6611■
1	1710	2.500-10	3.750	5.625	EY 6-4-6611-1■
1	1710	2.500-10	3.750	5.625	EY 6-4-6921-1X■
1	1710	2.500-10	3.750	5.625	EY 6-4-6921X■
1	1760	2.500-10	3.750	6.000	EY 6.3-4-651■
1	1760	2.500-10	3.750	6.031	EY 6.3-4-651-1■
1	1760	2.500-10	3.750	6.031	EY 6.3-4-781-1X■
1	1760	2.500-10	3.750	6.031	EY 6.3-4-781X■
1	1810	2.500-10	3.750	5.875	EY 6.5-4-3451■
1	1810	2.500-10	3.750	5.875	EY 6.5-4-3451-1■
1	1810	2.500-10	3.750	5.875	EY 6.5-4-3551-1X■
1	1810	2.500-10	3.750	5.875	EY 6.5-4-3551X■

T-14607					
1	SPL140	2.544-49	3.750	5.570	EY 140-4-141-1
1	SPL140	2.544-49	3.750	5.570	EY 140-4-151-1X
1	SPL170	2.544-49	3.750	6.000	EY 170-4-411-1■
1	SPL170	2.544-49	3.750	6.000	EY 170-4-421-1X■
1	SPL250	2.544-49	3.750	6.250	EY 250-4-151-1■
1	SPL250	2.544-49	3.750	6.250	EY 250-4-161-1X■
1	1710	2.544-49	3.755	5.625	EY 6-4-7041-1X■
1	1710	2.544-49	3.755	5.625	EY 6-4-7041X■
1	1710	2.544-49	3.755	5.625	EY 6-4-7051■
1	1710	2.544-49	3.755	5.625	EY 6-4-7051-1■
1	1760	2.544-49	3.750	6.031	EY 6.3-4-771-1X■
1	1760	2.544-49	3.750	6.031	EY 6.3-4-771X■
1	1760	2.544-49	3.750	6.031	EY 6.3-4-811■
1	1760	2.544-49	3.750	6.031	EY 6.3-4-811-1■
1	1810	2.024-39	3.000	5.188	EY 6.5-4-2471
1	1810	2.544-49	3.750	5.875	EY 6.5-4-3611■
1	1810	2.544-49	3.750	5.875	EY 6.5-4-3611-1■
1	1810	2.544-49	3.750	5.875	EY 6.5-4-3621-1X■
1	1810	2.544-49	3.750	5.875	EY 6.5-4-3621X■

*C/L to End of Hub for EY (End Yoke); Flange Face to End of Hub for CF (Companion Flange)

■ Hub machined for speedometer gear



Important: See Safety Information in General Information Section (J300P-GI)

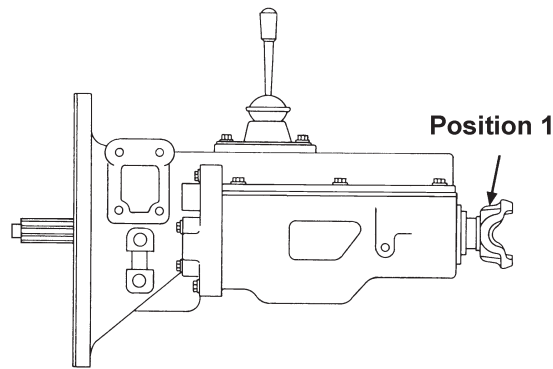

Pos	Series	Spline Data	Hub Dia	* to End of Hub	End Fitting Part Number
-----	--------	-------------	---------	-----------------	-------------------------

TA-4510

1	1710	2.500-10	3.750	3.625	CF 6-1-5541
1	1710	2.500-10	3.750	3.625	CF 6-1-5651X
1	1810	2.500-10	3.750	3.625	CF 6.5-1-2271
1	1810	2.500-10	3.750	3.625	CF 6.5-1-2351X
1	SPL140	2.500-10	3.750	5.960	EY 140-4-41-1
1	SPL140	2.500-10	3.750	5.960	EY 140-4-51-1X
1	SPL170	2.500-10	3.750	5.750	EY 170-4-471-1■
1	SPL170	2.500-10	3.750	5.750	EY 170-4-481-1X■
1	SPL250	2.500-10	3.750	6.062	EY 250-4-191-1■
1	SPL250	2.500-10	3.750	6.062	EY 250-4-201-1X■
1	1710	2.500-10	3.750	5.625	EY 6-4-6611■
1	1710	2.500-10	3.750	5.625	EY 6-4-6611-1■
1	1710	2.500-10	3.750	5.625	EY 6-4-6921-1X■
1	1710	2.500-10	3.750	5.625	EY 6-4-6921X■
1	1760	2.500-10	3.750	6.000	EY 6.3-4-651■
1	1760	2.500-10	3.750	6.031	EY 6.3-4-651-1■
1	1760	2.500-10	3.750	6.031	EY 6.3-4-781-1X■
1	1760	2.500-10	3.750	6.000	EY 6.3-4-781X■
1	1810	2.500-10	3.750	5.875	EY 6.5-4-3551-1X■
1	1810	2.500-10	3.750	5.875	EY 6.5-4-3551X■
1	1860	2.500-10	3.750	5.875	EY 6.5-4-3451■
1	1860	2.500-10	3.750	5.875	EY 6.5-4-3451-1■

TO-905

1	1610	2.250-10	3.500	3.625	CF 5-1-6331
1	1710	2.250-10	3.500	3.688	CF 6-1-951
1	1810	2.250-10	3.500	3.688	CF 6.5-1-151
1	SPL90	2.250-10	3.500	5.219	EY 90-4-151-1X
1	SPL90	2.250-10	3.750	5.219	EY 90-4-171-1X
					<i>Change seal to service older trans.</i>
1	1610	2.250-10	3.500	5.750	EY 5-4-4961
1	1610	2.250-10	3.500	5.750	EY 5-4-4961-1
1	1610	2.250-10	3.750	5.750	EY 5-4-7391-1X
1	1710	2.250-10	3.500	5.250	EY 6-4-6861
1	1710	2.250-10	3.500	5.250	EY 6-4-6861-1
1	1710	2.250-10	3.500	5.250	EY 6-4-6901-1X
1	1710	2.250-10	3.750	5.250	EY 6-4-7381-1X
					<i>Change seal to service older trans.</i>
1	1760	2.250-10	3.750	5.625	EY 6.3-4-1101-1X
					<i>Change seal to service older trans.</i>
1	1760	2.250-10	3.500	5.656	EY 6.3-4-701-1
1	1810	2.250-10	3.500	5.844	EY 6.5-4-2021

Pos	Series	Spline Data	Hub Dia	* to End of Hub	End Fitting Part Number
-----	--------	-------------	---------	-----------------	-------------------------

TO-955-AL, TO-955-ALL

1	1710	2.500-10	3.750	3.625	CF 6-1-5541
1	1710	2.500-10	3.750	3.625	CF 6-1-5651X
1	1810	2.500-10	3.750	3.625	CF 6.5-1-2271
1	1810	2.500-10	3.750	3.625	CF 6.5-1-2351X
1	SPL140	2.500-10	3.750	5.960	EY 140-4-41-1
1	SPL140	2.500-10	3.750	5.960	EY 140-4-51-1X
1	SPL170	2.500-10	3.750	5.750	EY 170-4-471-1■
1	SPL170	2.500-10	3.750	5.750	EY 170-4-481-1X■
1	SPL250	2.500-10	3.750	6.062	EY 250-4-191-1■
1	SPL250	2.500-10	3.750	6.062	EY 250-4-201-1X■
1	1610	2.500-10	3.750	6.125	EY 5-4-4971■
1	1710	2.500-10	3.750	5.625	EY 6-4-6611■
1	1710	2.500-10	3.750	5.625	EY 6-4-6611-1■
1	1710	2.500-10	3.750	5.625	EY 6-4-6921-1X■
1	1710	2.500-10	3.750	5.625	EY 6-4-6921X■
1	1760	2.500-10	3.750	6.000	EY 6.3-4-651■
1	1760	2.500-10	3.750	6.031	EY 6.3-4-651-1■
1	1760	2.500-10	3.750	6.031	EY 6.3-4-781-1X■
1	1760	2.500-10	3.750	6.000	EY 6.3-4-781X■
1	1760	2.500-10	3.750	6.000	EY 6.3-4-781X■
1	1810	2.500-10	3.750	5.875	EY 6.5-4-3551-1X■
1	1810	2.500-10	3.750	5.875	EY 6.5-4-3551X■
1	1810	2.500-10	3.750	5.875	EY 6.5-4-3451-1■
1	1810	2.500-10	3.750	5.875	EY 6.5-4-3551-1X■
1	1810	2.500-10	3.750	5.875	EY 6.5-4-3551X■

TS-1308-A

1	1810	2.750-10	3.750	4.062	CF 6.5-1-2361X
1	SPL140	2.750-10	3.750	6.570	EY 140-4-81-1
1	SPL140	2.750-10	3.750	6.570	EY 140-4-91-1X
1	SPL170	2.750-10	3.750	5.850	EY 170-4-511-1
1	SPL170	2.750-10	3.750	5.850	EY 170-4-521-1X
1	SPL250	2.750-10	3.750	6.297	EY 250-4-231-1
1	SPL250	2.750-10	3.750	6.297	EY 250-4-241-1X
1	1710	2.750-10	3.750	5.750	EY 6-4-6931-1X
1	1710	2.750-10	3.750	5.750	EY 6-4-6931X
1	1760	2.750-10	3.750	5.969	EY 6.3-4-791-1X
1	1760	2.750-10	3.750	5.969	EY 6.3-4-791X
1	1810	2.750-10	3.750	6.062	EY 6.5-4-3561-1X
1	1810	2.750-10	3.750	6.062	EY 6.5-4-3561X

TS-1312-A

1	1810	2.750-10	3.750	4.062	CF 6.5-1-2311
1	1810	2.750-10	3.750	4.062	CF 6.5-1-2361X
1	SPL140	2.750-10	3.750	6.570	EY 140-4-81-1
1	SPL140	2.750-10	3.750	6.570	EY 140-4-91-1X

*C/L to End of Hub for EY (End Yoke); Flange Face to End of Hub for CF (Companion Flange)

■ Hub machined for speedometer gear



Pos	Series	Spline Data	Hub Dia	* to End of Hub	End Fitting Part Number
TS-1312-A (Continued)					
1	SPL170	2.750-10	3.750	5.850	EY 170-4-511-1
1	SPL170	2.750-10	3.750	5.850	EY 170-4-521-1X
1	SPL250	2.750-10	3.750	6.297	EY 250-4-231-1
1	SPL250	2.750-10	3.750	6.297	EY 250-4-241-1X
1	1710	2.750-10	3.750	5.750	EY 6-4-6821
1	1710	2.750-10	3.750	5.750	EY 6-4-6821-1
1	1710	2.750-10	3.750	5.750	EY 6-4-6931-1X
1	1710	2.750-10	3.750	5.750	EY 6-4-6931X
1	1760	2.750-10	3.750	5.969	EY 6.3-4-711
1	1760	2.750-10	3.750	5.969	EY 6.3-4-711-1
1	1760	2.750-10	3.750	5.969	EY 6.3-4-791-1X
1	1760	2.750-10	3.750	5.969	EY 6.3-4-791X
1	1810	2.750-10	3.750	6.062	EY 6.5-4-3491
1	1810	2.750-10	3.750	6.062	EY 6.5-4-3491-1
1	1810	2.750-10	3.750	6.062	EY 6.5-4-3561-1X
1	1810	2.750-10	3.750	6.062	EY 6.5-4-3561X

TS-11612					
1	1760	2.794-54	3.750	5.970	EY 6.3-4-1051-1

2 SPEED 92					
1	1610	2.250-10	3.500	3.625	CF 5-1-6331
1	1810	2.250-10	3.500	3.688	CF 6.5-1-151
1	SPL170	2.250-10	3.500	5.750	EY 170-4-451-1
1	SPL170	2.250-10	3.500	5.750	EY 170-4-461-1X
1	SPL90	2.250-10	3.500	5.219	EY 90-4-151-1X
1	SPL90	2.250-10	3.500	5.219	EY 90-4-401-1
1	1610	2.250-10	3.500	5.750	EY 5-4-4961
1	1610	2.250-10	3.500	5.750	EY 5-4-4961-1
1	1710	2.250-10	3.500	5.250	EY 6-4-6861
1	1710	2.250-10	3.500	5.250	EY 6-4-6861-1
1	1710	2.250-10	3.500	5.250	EY 6-4-6901-1X
1	1810	2.250-10	3.500	5.844	EY 6.5-4-2021

3 SPEED 65					
1	1610	2.250-10	3.500	3.625	CF 5-1-6331
1	1810	2.250-10	3.500	3.688	CF 6.5-1-151
1	SPL170	2.250-10	3.500	5.750	EY 170-4-451-1
1	SPL170	2.250-10	3.500	5.750	EY 170-4-461-1X
1	SPL90	2.250-10	3.500	5.219	EY 90-4-401-1
1	1610	2.250-10	3.500	5.750	EY 5-4-4961
1	1610	2.250-10	3.500	5.750	EY 5-4-4961-1
1	1710	2.250-10	3.500	5.250	EY 6-4-6861
1	1710	2.250-10	3.500	5.250	EY 6-4-6861-1
1	1710	2.250-10	3.500	5.250	EY 6-4-6901-1X
1	1810	2.250-10	3.500	5.844	EY 6.5-4-2021

3 SPEED 92					
1	1610	2.250-10	3.500	3.625	CF 5-1-6331
1	1810	2.250-10	3.500	3.688	CF 6.5-1-151
1	SPL170	2.250-10	3.500	5.750	EY 170-4-451-1
1	SPL170	2.250-10	3.500	5.750	EY 170-4-461-1X
1	SPL90	2.250-10	3.500	5.219	EY 90-4-151-1X
1	SPL90	2.250-10	3.500	5.219	EY 90-4-401-1
1	1610	2.250-10	3.500	5.750	EY 5-4-4961
1	1610	2.250-10	3.500	5.750	EY 5-4-4961-1
1	1710	2.250-10	3.500	5.250	EY 6-4-6861
1	1710	2.250-10	3.500	5.250	EY 6-4-6861-1
1	1710	2.250-10	3.500	5.250	EY 6-4-6901-1X
1	1810	2.250-10	3.500	5.844	EY 6.5-4-2021

Pos	Series	Spline Data	Hub Dia	* to End of Hub	End Fitting Part Number
4 SPEED 75					
1	1610	2.250-10	3.500	3.625	CF 5-1-6331
1	1810	2.250-10	3.500	3.688	CF 6.5-1-151
1	SPL170	2.250-10	3.500	5.750	EY 170-4-451-1
1	SPL170	2.250-10	3.500	5.750	EY 170-4-461-1X
1	SPL90	2.250-10	3.500	5.219	EY 90-4-151-1X
1	SPL90	2.250-10	3.500	5.219	EY 90-4-401-1
1	1610	2.250-10	3.500	5.750	EY 5-4-4961
1	1610	2.250-10	3.500	5.750	EY 5-4-4961-1
1	1710	2.250-10	3.500	5.250	EY 6-4-6861
1	1710	2.250-10	3.500	5.250	EY 6-4-6861-1
1	1710	2.250-10	3.500	5.250	EY 6-4-6901-1X

4-A-86, 4-A-112, 4-A-860					
1	1610	2.250-10	3.500	3.625	CF 5-1-6331
1	1810	2.250-10	3.500	3.688	CF 6.5-1-151
1	SPL170	2.250-10	3.500	5.750	EY 170-4-451-1
1	SPL170	2.250-10	3.500	5.750	EY 170-4-461-1X
1	SPL90	2.250-10	3.500	5.219	EY 90-4-151-1X
1	SPL90	2.250-10	3.500	5.219	EY 90-4-401-1
1	1550	2.250-10	3.500	5.125	EY 4-4-3501-1
1	1610	2.250-10	3.500	5.750	EY 5-4-4961
1	1610	2.250-10	3.500	5.750	EY 5-4-4961-1
1	1710	2.250-10	3.500	5.250	EY 6-4-6861
1	1710	2.250-10	3.500	5.250	EY 6-4-6861-1
1	1710	2.250-10	3.500	5.250	EY 6-4-6901-1X
1	1810	2.250-10	3.500	5.844	EY 6.5-4-2021

4-F-1440					
1	1810	2.750-10	3.750	4.062	CF 6.5-1-2311
1	1810	2.750-10	3.750	4.062	CF 6.5-1-2361X
1	SPL140	2.750-10	3.750	6.570	EY 140-4-91-1X
1	SPL170	2.750-10	3.750	5.850	EY 170-4-511-1
1	SPL170	2.750-10	3.750	5.850	EY 170-4-521-1X
1	SPL250	2.750-10	3.750	6.297	EY 250-4-231-1
1	SPL250	2.750-10	3.750	6.297	EY 250-4-241-1X
1	1710	2.750-10	3.750	5.750	EY 6-4-6821
1	1710	2.750-10	3.750	5.750	EY 6-4-6821-1
1	1710	2.750-10	3.750	5.750	EY 6-4-6931-1X
1	1710	2.750-10	3.750	5.750	EY 6-4-6931X
1	1760	2.750-10	3.750	5.969	EY 6.3-4-711
1	1760	2.750-10	3.750	5.969	EY 6.3-4-711-1
1	1760	2.750-10	3.750	5.969	EY 6.3-4-791-1X
1	1760	2.750-10	3.750	5.969	EY 6.3-4-791X
1	1810	2.750-10	3.750	6.062	EY 6.5-4-3491
1	1810	2.750-10	3.750	6.062	EY 6.5-4-3491-1
1	1810	2.750-10	3.750	6.062	EY 6.5-4-3561-1X
1	1810	2.750-10	3.750	6.062	EY 6.5-4-3561X

4-FS-1440					
1	SPL140	2.750-10	3.750	6.570	EY 140-4-81-1
1	SPL140	2.750-10	3.750	6.570	EY 140-4-91-1X
1	SPL170	2.750-10	3.750	5.850	EY 170-4-511-1
1	SPL170	2.750-10	3.750	5.850	EY 170-4-521-1X
1	SPL250	2.750-10	3.750	6.297	EY 250-4-231-1
1	SPL250	2.750-10	3.750	6.297	EY 250-4-241-1X
1	1710	2.750-10	3.750	5.750	EY 6-4-6821
1	1710	2.750-10	3.750	5.750	EY 6-4-6821-1
1	1710	2.750-10	3.750	5.750	EY 6-4-6931-1X
1	1710	2.750-10	3.750	5.750	EY 6-4-6931X
1	1760	2.750-10	3.750	5.969	EY 6.3-4-711

*C/L to End of Hub for EY (End Yoke); Flange Face to End of Hub for CF (Companion Flange)

■ Hub machined for speedometer gear



Important: See Safety Information in General Information Section (J300P-GI)

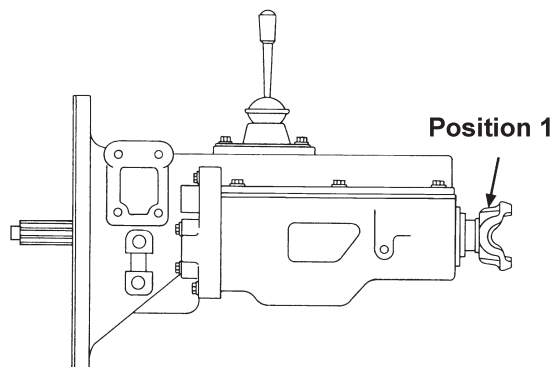

Pos	Series	Spline Data	Hub Dia	* to End of Hub	End Fitting Part Number
-----	--------	-------------	---------	-----------------	-------------------------

4-FS-1440 (Continued)

1	1760	2.750-10	3.750	5.969	EY 6.3-4-711-1
1	1760	2.750-10	3.750	5.969	EY 6.3-4-791-1X
1	1760	2.750-10	3.750	5.969	EY 6.3-4-791X
1	1810	2.750-10	3.750	6.062	EY 6.5-4-3491
1	1810	2.750-10	3.750	6.062	EY 6.5-4-3491-1
1	1810	2.750-10	3.750	6.062	EY 6.5-4-3561-1X
1	1810	2.750-10	3.750	6.062	EY 6.5-4-3561X

4-MS-1440

1	1810	2.750-10	3.750	4.062	CF 6.5-1-2361X <i>Can be used w/brake</i>
1	SPL140	2.750-10	3.750	6.570	EY 140-4-81-1 <i>Can be used w/brake</i>
1	SPL140	2.750-10	3.750	6.570	EY 140-4-91-1X <i>Can be used w/brake</i>
1	SPL170	2.750-10	3.750	5.850	EY 170-4-511-1 <i>Can be used w/brake</i>
1	SPL170	2.750-10	3.750	5.850	EY 170-4-521-1X <i>Can be used w/brake</i>
1	SPL250	2.750-10	3.750	6.297	EY 250-4-231-1 <i>Can be used w/brake</i>
1	SPL250	2.750-10	3.750	6.297	EY 250-4-241-1X <i>Can be used w/brake</i>
1	1710	2.750-10	3.750	5.750	EY 6-4-6931-1X <i>Can be used w/brake</i>
1	1710	2.750-10	3.750	5.750	EY 6-4-6931X <i>Can be used w/brake</i>
1	1760	2.750-10	3.750	5.969	EY 6.3-4-791-1X <i>Can be used w/brake</i>
1	1760	2.750-10	3.750	5.969	EY 6.3-4-791X <i>Can be used w/brake</i>
1	1810	2.750-10	3.750	6.062	EY 6.5-4-3561-1X <i>Can be used w/brake</i>
1	1810	2.750-10	3.750	6.062	EY 6.5-4-3561X <i>Can be used w/brake</i>

5-A-1120

1	1610	2.250-10	3.500	3.625	CF 5-1-6331
1	1710	2.250-10	3.500	3.688	CF 6-1-951
1	1810	2.250-10	3.500	3.688	CF 6.5-1-151
1	SPL90	2.250-10	3.500	5.219	EY 90-4-151-1X
1	SPL90	2.250-10	3.500	5.219	EY 90-4-401-1
1	1550	2.250-10	3.500	5.125	EY 4-4-3501-1
1	1610	2.250-10	3.500	5.750	EY 5-4-4961
1	1610	2.250-10	3.500	5.750	EY 5-4-4961-1
1	1710	2.250-10	3.500	5.250	EY 6-4-6861
1	1710	2.250-10	3.500	5.250	EY 6-4-6861-1

Pos	Series	Spline Data	Hub Dia	* to End of Hub	End Fitting Part Number
-----	--------	-------------	---------	-----------------	-------------------------

5-A-1120 (Continued)

1	1710	2.250-10	3.500	5.250	EY 6-4-6901-1X
1	1760	2.250-10	3.500	5.656	EY 6.3-4-701-1
1	1760	2.250-10	3.500	5.656	EY 6.3-4-761-1X
1	1810	2.250-10	3.500	5.844	EY 6.5-4-2021

5-A-65, 5-A-650, 5-AW-65, 5-AW-650, 5-C-65, 5-C-650, 5-C-72, 5-C-720, 5-CW-65, 5-CW-650

1	1610	2.000-10	3.250	3.625	CF 5-1-931
1	1710	2.000-10	3.250	5.625	EY 6-4-2001

5-F-1220, 5-G-1220

1	1610	2.250-10	3.500	3.625	CF 5-1-6331
1	1710	2.250-10	3.500	3.688	CF 6-1-951
1	1810	2.250-10	3.500	3.688	CF 6.5-1-151
1	SPL90	2.250-10	3.500	5.219	EY 90-4-151-1X
1	SPL90	2.250-10	3.500	5.219	EY 90-4-401-1
1	1550	2.250-10	3.500	5.125	EY 4-4-3501-1
1	1610	2.250-10	3.500	5.750	EY 5-4-4961
1	1610	2.250-10	3.500	5.750	EY 5-4-4961-1
1	1710	2.250-10	3.500	5.250	EY 6-4-6861
1	1710	2.250-10	3.500	5.250	EY 6-4-6861-1
1	1760	2.250-10	3.500	5.656	EY 6.3-4-701-1
1	1760	2.250-10	3.500	5.656	EY 6.3-4-761-1X
1	1810	2.250-10	3.500	5.844	EY 6.5-4-2021

5-H-74T, 5-H-75T, 5-H-740T, 5-HA-75T, 5-SPEED-65, 5-SPEED-74, 5-SPEED-75, 5-SPEED-650, 5-SPEED-740, 5-W-74

1	1610	2.000-10	3.250	3.625	CF 5-1-931
1	1710	2.000-10	3.250	5.625	EY 6-4-2001

10-A-1120, 10-B-1120, 10-C-1120, 10-F-1120, 10-FA-65, 10-FA-650, 10-FB-65, 10-FB-650

1	1610	2.250-10	3.500	3.625	CF 5-1-6331
1	1710	2.250-10	3.500	3.688	CF 6-1-951
1	1810	2.250-10	3.500	3.688	CF 6.5-1-151
1	SPL90	2.250-10	3.500	5.219	EY 90-4-151-1X
1	SPL90	2.250-10	3.500	5.219	EY 90-4-401-1
1	1550	2.250-10	3.500	5.125	EY 4-4-3501-1
1	1610	2.250-10	3.500	5.750	EY 5-4-4961
1	1610	2.250-10	3.500	5.750	EY 5-4-4961-1
1	1710	2.250-10	3.500	5.250	EY 6-4-6861
1	1710	2.250-10	3.500	5.250	EY 6-4-6861-1
1	1710	2.250-10	3.500	5.250	EY 6-4-6901-1X
1	1760	2.250-10	3.500	5.656	EY 6.3-4-701-1
1	1760	2.250-10	3.500	5.656	EY 6.3-4-761-1X
1	1810	2.250-10	3.500	5.844	EY 6.5-4-2021

*C/L to End of Hub for EY (End Yoke); Flange Face to End of Hub for CF (Companion Flange)

■ Hub machined for speedometer gear



Pos	Series	Spline Data	Hub Dia	* to End of Hub	End Fitting Part Number
10-SPEED-65, 10-SPEED-650, 10-SPEED-1120					
1	1610	2.250-10	3.500	3.625	CF 5-1-6331
1	1810	2.250-10	3.500	3.688	CF 6.5-1-151
1	SPL170	2.250-10	3.500	5.750	EY 170-4-451-1
1	SPL170	2.250-10	3.500	5.750	EY 170-4-461-1X
1	SPL90	2.250-10	3.500	5.219	EY 90-4-151-1X
1	SPL90	2.250-10	3.500	5.219	EY 90-4-401-1
1	1610	2.250-10	3.500	5.750	EY 5-4-4961
1	1610	2.250-10	3.500	5.750	EY 5-4-4961-1
1	1710	2.250-10	3.500	5.250	EY 6-4-6861
1	1710	2.250-10	3.500	5.250	EY 6-4-6861-1
1	1710	2.250-10	3.500	5.250	EY 6-4-6901-1X
1	1810	2.250-10	3.500	5.844	EY 6.5-4-2021

15-G-1120, 15-H-1120					
1	1610	2.250-10	3.500	3.625	CF 5-1-6331
1	1710	2.250-10	3.500	3.688	CF 6-1-951
1	1810	2.250-10	3.500	3.688	CF 6.5-1-151
1	SPL90	2.250-10	3.500	5.219	EY 90-4-151-1X
1	SPL90	2.250-10	3.500	5.219	EY 90-4-401-1
1	1550	2.250-10	3.500	5.125	EY 4-4-3501-1
1	1610	2.250-10	3.500	5.750	EY 5-4-4961
1	1610	2.250-10	3.500	5.750	EY 5-4-4961-1
1	1710	2.250-10	3.500	5.250	EY 6-4-6861
1	1710	2.250-10	3.500	5.250	EY 6-4-6861-1
1	1710	2.250-10	3.500	5.250	EY 6-4-6901-1X
1	1760	2.250-10	3.500	5.656	EY 6.3-4-701-1
1	1760	2.250-10	3.500	5.656	EY 6.3-4-761-1X
1	1810	2.250-10	3.500	5.844	EY 6.5-4-2021

15-SPEED-1120					
1	1610	2.250-10	3.500	3.625	CF 5-1-6331
1	1810	2.250-10	3.500	3.688	CF 6.5-1-151
1	SPL170	2.250-10	3.500	5.750	EY 170-4-451-1
1	SPL170	2.250-10	3.500	5.750	EY 170-4-461-1X
1	SPL90	2.250-10	3.500	5.219	EY 90-4-151-1X
1	SPL90	2.250-10	3.500	5.219	EY 90-4-401-1
1	1610	2.250-10	3.500	5.750	EY 5-4-4961
1	1610	2.250-10	3.500	5.750	EY 5-4-4961-1
1	1710	2.250-10	3.500	5.250	EY 6-4-6861
1	1710	2.250-10	3.500	5.250	EY 6-4-6861-1
1	1710	2.250-10	3.500	5.250	EY 6-4-6901-1X
1	1810	2.250-10	3.500	5.844	EY 6.5-4-2021

62, 65/650, 72/720, 74/740, 75					
1	1610	2.000-10	3.250	3.625	CF 5-1-931
1	1710	2.000-10	3.250	5.625	EY 6-4-2001

140-4-41-1					
1	SPL140	2.750-10	3.750	6.570	EY 140-4-81-1

5106					
1	1610	1.998-38	2.750	4.688	CF 5-1-6471X <i>Can be used w/brake; Assy includes eight 6-73-725 bolts</i>

Pos	Series	Spline Data	Hub Dia	* to End of Hub	End Fitting Part Number
-----	--------	-------------	---------	-----------------	-------------------------

*C/L to End of Hub for EY (End Yoke); Flange Face to End of Hub for CF (Companion Flange)

■ Hub machined for speedometer gear



Important: See Safety Information in General Information Section (J300P-GI)

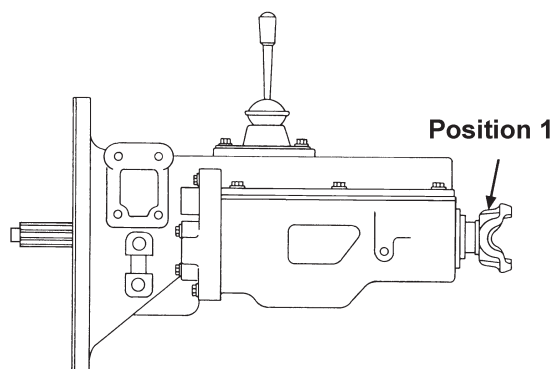

Pos	Series	Spline Data	Hub Dia	* to End of Hub	End Fitting Part Number
T-200					
1	1810	2.374-46	3.750	3.109	CF 6.5-1-2441■
1	SPL170	2.374-46	3.750	5.190	EY 170-4-1171-1
1	SPL170	2.374-46	3.750	5.190	EY 170-4-1191-1X
<i>Assy includes electronic speedometer gear #231528</i>					
1	SPL250	2.374-46	3.750	5.410	EY 250-4-601-1
1	SPL250	2.374-46	3.750	5.410	EY 250-4-621-1X
<i>Assy includes electronic speedometer gear #231528</i>					
1	SPL250	2.374-46	3.750	6.650	EY 250-4-791-1
1	SPL250	2.374-46	3.750	6.650	EY 250-4-801-1X
1	1710	2.374-46	3.752	4.938	EY 6-4-6601
<i>Hub mach. for speedometer gear</i>					
1	1710	2.374-46	3.752	4.938	EY 6-4-6601-1
<i>Hub mach. for speedometer gear</i>					
1	1710	2.374-46	3.752	4.938	EY 6-4-7881-1X
<i>W/mechanical speedo pickup</i>					
<i>Hub mach. for speedometer gear; Assy inc. mech. speedo gear</i>					
1	1710	2.374-46	3.752	4.938	EY 6-4-7881X
<i>W/mechanical speedo pickup</i>					
<i>Hub mach. for speedometer gear; Assy inc. mech. speedo gear</i>					
1	1710	2.374-46	3.752	4.938	EY 6-4-7891-1X
<i>W/Electronic speedo pickup</i>					
<i>Hub mach. for speedometer gear; Assy inc. elec. speedo gear</i>					
1	1760	2.374-46	3.750	5.406	EY 6.3-4-1271-1X
<i>W/mechanical speedo pickup</i>					
<i>Assy includes mechanical speedometer drive gear #231527</i>					
1	1760	2.374-46	3.750	5.406	EY 6.3-4-1281-1X
<i>W/Electronic speedo pickup</i>					
<i>Assy includes electronic speedometer gear #231528</i>					
1	1760	2.374-46	3.750	5.406	EY 6.3-4-1281X
<i>W/Electronic speedo pickup</i>					
<i>Assy includes electronic speedometer gear #231528</i>					
1	1760	2.374-46	3.750	5.406	EY 6.3-4-641
1	1760	2.374-46	3.750	5.406	EY 6.3-4-641-1
1	1810	2.374-46	3.750	5.219	EY 6.5-4-3441
1	1810	2.374-46	3.750	5.219	EY 6.5-4-3441-1
1	1810	2.374-46	3.750	5.219	EY 6.5-4-4001-1X
<i>W/mechanical speedo pickup</i>					
<i>Assy includes mechanical speedometer drive gear #231527</i>					
1	1810	2.374-46	3.750	5.219	EY 6.5-4-4001X
<i>W/mechanical speedo pickup</i>					
<i>Assy includes mechanical speedometer drive gear #231527</i>					
1	1810	2.374-46	3.750	5.219	EY 6.5-4-4011-1X
<i>W/Electronic speedo pickup</i>					
<i>Assy includes electronic speedometer gear #231528</i>					
1	1810	2.374-46	3.750	5.219	EY 6.5-4-4011X
<i>W/Electronic speedo pickup</i>					
<i>Assy includes electronic speedometer gear #231528</i>					
1	1820	2.375-46	3.750	3.938	EY 8-4-1141

Pos	Series	Spline Data	Hub Dia	* to End of Hub	End Fitting Part Number
T-200 (Continued)					
1	1810	2.374-46	3.750	3.109	CF 6.5-1-2441■
1	1820	2.375-46	3.750	3.938	EY 8-4-1151X
<i>W/mechanical speedo pickup</i>					
<i>Assy includes mechanical speedometer drive gear #231527</i>					
1	1820	2.375-46	3.750	3.938	EY 8-4-1161X
<i>W/Electronic speedo pickup</i>					
<i>Assy includes electronic speedometer gear #231528</i>					
T-2050, T-2060					
1	1810	2.374-46	3.750	3.109	CF 6.5-1-2441■
1	SPL170	2.374-46	3.750	5.190	EY 170-4-1171-1
1	SPL170	2.374-46	3.750	5.190	EY 170-4-1191-1X
<i>Assy includes electronic speedometer gear #231528</i>					
1	SPL250	2.374-46	3.750	5.410	EY 250-4-601-1
1	SPL250	2.374-46	3.750	5.410	EY 250-4-621-1X
<i>Assy includes electronic speedometer gear #231528</i>					
1	SPL250	2.374-46	3.750	6.650	EY 250-4-791-1
1	SPL250	2.374-46	3.750	6.650	EY 250-4-801-1X
1	1710	2.374-46	3.752	4.938	EY 6-4-6601
<i>Hub mach. for speedometer gear</i>					
1	1710	2.374-46	3.752	4.938	EY 6-4-6601-1
<i>Hub mach. for speedometer gear</i>					
1	1710	2.374-46	3.752	4.938	EY 6-4-7881-1X
<i>W/mechanical speedo pickup</i>					
<i>Hub mach. for speedometer gear; Assy inc. mech. speedo gear</i>					
1	1710	2.374-46	3.752	4.938	EY 6-4-7881X
<i>W/mechanical speedo pickup</i>					
<i>Hub mach. for speedometer gear; Assy inc. mech. speedo gear</i>					
1	1710	2.374-46	3.752	4.938	EY 6-4-7891-1X
<i>W/Electronic speedo pickup</i>					
<i>Hub mach. for speedometer gear; Assy inc. elec. speedo gear</i>					
1	1760	2.374-46	3.750	5.406	EY 6.3-4-1271-1X
<i>W/mechanical speedo pickup</i>					
<i>Assy includes mechanical speedometer drive gear #231527</i>					
1	1760	2.374-46	3.750	5.406	EY 6.3-4-1281-1X
<i>W/Electronic speedo pickup</i>					
<i>Assy includes electronic speedometer gear #231528</i>					
1	1760	2.374-46	3.750	5.406	EY 6.3-4-1281X
<i>W/Electronic speedo pickup</i>					
<i>Assy includes electronic speedometer gear #231528</i>					
1	1760	2.374-46	3.750	5.406	EY 6.3-4-641
1	1760	2.374-46	3.750	5.406	EY 6.3-4-641-1
1	1810	2.374-46	3.750	5.219	EY 6.5-4-3441
1	1810	2.374-46	3.750	5.219	EY 6.5-4-3441-1
1	1810	2.374-46	3.750	5.219	EY 6.5-4-4001-1X
<i>W/mechanical speedo pickup</i>					
<i>Assy includes mechanical speedometer drive gear #231527</i>					
1	1760	2.374-46	3.750	5.406	EY 6.3-4-1281-1X
<i>W/Electronic speedo pickup</i>					
<i>Assy includes electronic speedometer gear #231528</i>					
1	1760	2.374-46	3.750	5.406	EY 6.3-4-1281X
<i>W/Electronic speedo pickup</i>					
<i>Assy includes electronic speedometer gear #231528</i>					
1	1810	2.374-46	3.750	5.219	EY 6.5-4-3441
1	1810	2.374-46	3.750	5.219	EY 6.5-4-3441-1
1	1810	2.374-46	3.750	5.219	EY 6.5-4-4001-1X
<i>W/mechanical speedo pickup</i>					
<i>Assy includes mechanical speedometer drive gear #231527</i>					
1	1810	2.374-46	3.750	5.219	EY 6.5-4-4001X
<i>W/mechanical speedo pickup</i>					
<i>Assy includes mechanical speedometer drive gear #231527</i>					

*C/L to End of Hub for EY (End Yoke); Flange Face to End of Hub for CF (Companion Flange)

■ Hub machined for speedometer gear



Pos	Series	Spline Data	Hub Dia	* to End of Hub	End Fitting Part Number
T-2050, T-2060 (Continued)					
1	1810	2.374-46	3.750	5.219	EY 6.5-4-4011-1X <i>W/Electronic speedo pickup</i>
					<i>Assy includes electronic speedometer gear #231528</i>
1	1810	2.374-46	3.750	5.219	EY 6.5-4-4011X <i>W/Electronic speedo pickup</i>
					<i>Assy includes electronic speedometer gear #231528</i>
1	1820	2.375-46	3.750	3.938	EY 8-4-1141 <i>W/mechanical speedo pickup</i>
					<i>Assy includes mechanical speedometer drive gear #231527</i>
1	1820	2.375-46	3.750	3.938	EY 8-4-1151X <i>W/mechanical speedo pickup</i>
					<i>Assy includes mechanical speedometer drive gear #231527</i>
1	1820	2.375-46	3.750	3.938	EY 8-4-1161X <i>W/Electronic speedo pickup</i>
					<i>Assy includes electronic speedometer gear #231528</i>
T-2090, T-2100					
1	1760	2.374-46	3.750	5.406	EY 6.3-4-641
1	1810	2.374-46	3.750	5.219	EY 6.5-4-4001X <i>W/mechanical speedo pickup</i>
					<i>Assy includes mechanical speedometer drive gear #231527</i>
1	1810	2.374-46	3.750	5.219	EY 6.5-4-4011X <i>W/Electronic speedo pickup</i>
					<i>Assy includes electronic speedometer gear #231528</i>
T-300					
1	SPL350	2.374-46	3.751	5.642	EY 350-4-91-1X <i>Assy includes electronic speedometer gear #231528</i>
TR-671, TR-6710					
1	1610	2.260-6	3.250	4.938	EY 5-4-1891
1	1610	2.260-6	3.250	4.938	EY 5-4-1891-1
1	1610	2.260-6	3.250	4.938	EY 5-4-8211-1X
TR-772, TR-7220					
1	1710	2.250-10	3.250	5.250	EY 6-4-1971
TRD-67, TRD-670, TRD-675					
1	1610	2.260-6	3.250	4.938	EY 5-4-1891
1	1610	2.260-6	3.250	4.938	EY 5-4-1891-1
1	1610	2.260-6	3.250	4.938	EY 5-4-8211-1X
TRD-722, TRD-7220, TRD-7225, TRD-72250					
1	1710	2.250-10	3.250	5.250	EY 6-4-1971
TRDL-1070					
1	SPL170	2.374-46	3.500	5.880	EY 170-4-1211-1
1	SPL170	2.374-46	3.500	5.880	EY 170-4-1221-1X
1	SPL250	2.374-46	3.500	6.140	EY 250-4-641-1
1	SPL250	2.374-46	3.500	6.140	EY 250-4-651-1X
1	1710	2.374-46	3.500	5.156	EY 6-4-5841
1	1710	2.374-46	3.500	5.156	EY 6-4-8341-1X
1	1710	2.374-46	3.500	5.840	EY 6-4-8951-1
1	1760	2.374-46	3.500	5.375	EY 6.3-4-1391-1X
1	1760	2.374-46	3.500	5.375	EY 6.3-4-391
1	1760	2.374-46	3.500	5.375	EY 6.3-4-391-1
1	1810	2.374-46	3.500	5.406	EY 6.5-4-3251
1	1810	2.374-46	3.500	5.406	EY 6.5-4-3251-1
1	1810	2.374-46	3.500	5.406	EY 6.5-4-4271-1X
TRDL-722, TRDL-7220, TRDL-7225, TRDL-72250					
1	1710	2.250-10	3.250	5.250	EY 6-4-1971
TRDLG-1070					
1	SPL170	2.374-46	3.500	5.880	EY 170-4-1211-1
1	SPL170	2.374-46	3.500	5.880	EY 170-4-1221-1X
1	SPL250	2.374-46	3.500	6.140	EY 250-4-641-1

Pos	Series	Spline Data	Hub Dia	* to End of Hub	End Fitting Part Number
TRDLG-1070 (Continued)					
1	SPL250	2.374-46	3.500	6.140	EY 250-4-651-1X
1	1710	2.374-46	3.500	5.156	EY 6-4-5841
1	1710	2.374-46	3.500	5.156	EY 6-4-8341-1X
1	1760	2.374-46	3.500	5.375	EY 6.3-4-1391-1X
1	1760	2.374-46	3.500	5.375	EY 6.3-4-391
1	1760	2.374-46	3.500	5.375	EY 6.3-4-391-1
1	1810	2.374-46	3.500	5.406	EY 6.5-4-3251
1	1810	2.374-46	3.500	5.406	EY 6.5-4-3251-1
1	1810	2.374-46	3.500	5.406	EY 6.5-4-4271-1X
TRDXL-1070					
1	SPL170	2.374-46	3.500	5.880	EY 170-4-1211-1
1	SPL170	2.374-46	3.500	5.880	EY 170-4-1221-1X
1	SPL250	2.374-46	3.500	6.140	EY 250-4-641-1
1	SPL250	2.374-46	3.500	6.140	EY 250-4-651-1X
1	1710	2.500-10	3.500	5.156	EY 6-4-4421
1	1710	2.500-10	3.500	5.156	EY 6-4-4421-1
1	1710	2.374-46	3.500	5.156	EY 6-4-5841
1	1710	2.374-46	3.500	5.156	EY 6-4-5841-1
1	1710	2.374-46	3.500	5.156	EY 6-4-8341-1X
1	1710	2.500-10	3.500	5.156	EY 6-4-8351-1X
1	1710	2.374-46	3.500	5.840	EY 6-4-8951-1
1	1710	2.374-46	3.500	5.840	EY 6-4-8961-1X
1	1760	2.374-46	3.500	5.375	EY 6.3-4-1391-1X
1	1760	2.374-46	3.500	5.375	EY 6.3-4-391
1	1760	2.374-46	3.500	5.375	EY 6.3-4-391-1
1	1810	2.374-46	3.500	5.406	EY 6.5-4-3251
1	1810	2.374-46	3.500	5.406	EY 6.5-4-3251-1
1	1810	2.374-46	3.500	5.406	EY 6.5-4-4271-1X
TRL-***					
1	SPL170	2.374-46	3.500	5.880	EY 170-4-1211-1
1	SPL170	2.374-46	3.500	5.880	EY 170-4-1221-1X
1	SPL250	2.374-46	3.500	6.140	EY 250-4-641-1
1	SPL250	2.374-46	3.500	6.140	EY 250-4-651-1X
1	1710	2.500-10	3.500	5.156	EY 6-4-4421
1	1710	2.500-10	3.500	5.156	EY 6-4-4421-1
1	1710	2.374-46	3.500	5.156	EY 6-4-5841
1	1710	2.374-46	3.500	5.156	EY 6-4-5841-1
1	1710	2.374-46	3.500	5.840	EY 6-4-8951-1
1	1710	2.374-46	3.500	5.840	EY 6-4-8961-1X
1	1760	2.374-46	3.500	5.375	EY 6.3-4-1391-1X
1	1760	2.374-46	3.500	5.375	EY 6.3-4-1391X
1	1760	2.500-10	3.500	5.406	EY 6.3-4-151
1	1760	2.374-46	3.500	5.375	EY 6.3-4-391
1	1760	2.374-46	3.500	5.375	EY 6.3-4-391-1
1	1810	2.374-46	3.500	5.406	EY 6.5-4-3251
1	1810	2.374-46	3.500	5.406	EY 6.5-4-3251-1
TRQL-7220, TRT-722, TRT-7220, TRTL-722, TRTL-7220,					
1	1710	2.250-10	3.250	5.250	EY 6-4-1971
TRTX-670					
1	1610	2.260-6	3.250	4.938	EY 5-4-1891
1	1610	2.260-6	3.250	4.938	EY 5-4-1891-1
1	1610	2.260-6	3.250	4.938	EY 5-4-8211-1X

*C/L to End of Hub for EY (End Yoke); Flange Face to End of Hub for CF (Companion Flange)

■ Hub machined for speedometer gear



Important: See Safety Information in General Information Section (J300P-GI)

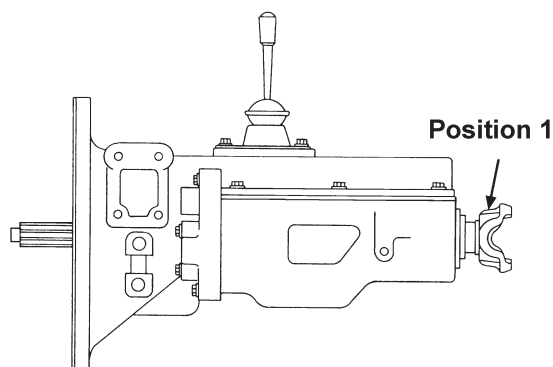

Pos	Series	Spline Data	Hub Dia	* to End of Hub	End Fitting Part Number
-----	--------	-------------	---------	-----------------	-------------------------

Pos	Series	Spline Data	Hub Dia	* to End of Hub	End Fitting Part Number
-----	--------	-------------	---------	-----------------	-------------------------

MACK

TRTXL-***

1	SPL170	2.374-46	3.500	5.880	EY 170-4-1211-1
1	SPL250	2.374-46	3.500	6.140	EY 250-4-641-1
1	1710	2.374-46	3.500	5.156	EY 6-4-5841
1	1710	2.374-46	3.500	5.156	EY 6-4-5841-1
1	1710	2.374-46	3.500	5.840	EY 6-4-8951-1
1	1710	2.374-46	3.500	5.840	EY 6-4-8961-1X
1	1760	2.374-46	3.500	5.375	EY 6.3-4-391
1	1760	2.374-46	3.500	5.375	EY 6.3-4-391-1
1	1810	2.374-46	3.500	5.406	EY 6.5-4-3251
1	1810	2.374-46	3.500	5.406	EY 6.5-4-3251-1

TRXL-***

1	SPL170	2.374-46	3.500	5.880	EY 170-4-1211-1
1	SPL250	2.374-46	3.500	6.140	EY 250-4-641-1
1	1710	2.374-46	3.500	5.156	EY 6-4-5841
1	1710	2.374-46	3.500	5.156	EY 6-4-5841-1
1	1710	2.374-46	3.500	5.840	EY 6-4-8951-1
1	1710	2.374-46	3.500	5.840	EY 6-4-8961-1X
1	1760	2.374-46	3.500	5.375	EY 6.3-4-1391-1X
1	1760	2.374-46	3.500	5.375	EY 6.3-4-1391X
1	1760	2.374-46	3.500	5.375	EY 6.3-4-391
1	1760	2.374-46	3.500	5.375	EY 6.3-4-391-1
1	1810	2.374-46	3.500	5.406	EY 6.5-4-3251
1	1810	2.374-46	3.500	5.406	EY 6.5-4-3251-1

NEW PROCESS

420

1	1350/1410	1.500-10	2.125	2.562	CF 3-1-1151
---	-----------	----------	-------	-------	-------------

420-435

1	1310	1.375-10	2.125	3.438	EY 2-4-1731 <i>Hub diameter not ground</i>
1	1350	1.375-10	2.125	3.688	EY 3-4-3291-1
1	1350	1.401-32	2.125	4.750	EY 3-4-7241
1	1350	1.401-32	2.125	4.750	EY 3-4-7241-1
1	1410	1.375-10	2.125	3.685	EY 3-4-2271-1
1	1410	1.500-10	2.125	3.688	EY 3-4-3961-1
1	1410	1.525-35	2.125	3.688	EY 3-4-5191-1
1	1410	1.525-35	2.500	5.750	EY 3-4-7151

*Can be used w/brake
 Flanged end yoke, strap kit not furnished by Dana*

1	1480	1.525-35	2.125	4.031	EY 3-4-6691-1
1	1480	1.375-10	2.125	4.031	EY 3-4-6701
1	1480	1.525-35	2.500	5.750	EY 3-4-7161

*Can be used w/brake
 Flanged end yoke.*

540-542

1	1310	1.375-10	2.125	3.438	EY 2-4-1731 <i>Hub diameter not ground</i>
1	1350	1.375-10	2.125	3.688	EY 3-4-3291-1
1	1350	1.401-32	2.125	4.750	EY 3-4-7241
1	1350	1.401-32	2.125	4.750	EY 3-4-7241-1
1	1410	1.375-10	2.125	3.685	EY 3-4-2271-1
1	1410	1.500-10	2.125	3.688	EY 3-4-3961-1
1	1410	1.525-35	2.125	3.688	EY 3-4-5191-1
1	1410	1.525-35	2.500	5.750	EY 3-4-7151

*Can be used w/brake
 Flanged end yoke, strap kit not furnished by Dana*

1	1480	1.525-35	2.125	4.031	EY 3-4-6691-1
1	1480	1.375-10	2.125	4.031	EY 3-4-6701
1	1480	1.750-10	2.500	5.750	EY 3-4-7131

Flanged end yoke, strap kit not furnished by Dana

1	1480	1.525-35	2.500	5.750	EY 3-4-7161
---	------	----------	-------	-------	-------------

*Can be used w/brake
 Flanged end yoke.*

*C/L to End of Hub for EY (End Yoke); Flange Face to End of Hub for CF (Companion Flange)

■ Hub machined for speedometer gear



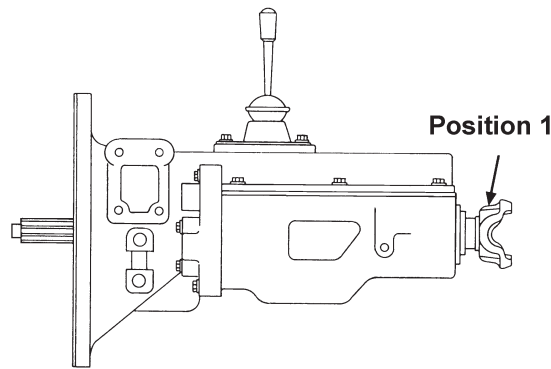

Pos	Series	Spline Data	Hub Dia	* to End of Hub	End Fitting Part Number
-----	--------	-------------	---------	-----------------	-------------------------

M-11G9A-M11, M-11G10A-M11, M-12G9A-M12, M-12G10A-M12,

1	SPL140	2.500-10	3.750	5.960	EY 140-4-41-1
1	SPL140	2.500-10	3.750	5.960	EY 140-4-51-1X
1	SPL170	2.500-10	3.750	5.750	EY 170-4-471-1■
1	SPL170	2.500-10	3.750	5.750	EY 170-4-481-1X■
1	SPL250	2.500-10	3.750	6.062	EY 250-4-191-1■
1	SPL250	2.500-10	3.750	6.062	EY 250-4-201-1X■
1	1710	2.500-10	3.750	5.625	EY 6-4-6611■
1	1710	2.500-10	3.750	5.625	EY 6-4-6611-1■
1	1710	2.500-10	3.750	5.625	EY 6-4-6921-1X■
1	1710	2.500-10	3.750	5.625	EY 6-4-6921X■
1	1760	2.500-10	3.750	6.000	EY 6.3-4-651■
1	1760	2.500-10	3.750	6.031	EY 6.3-4-651-1■
1	1760	2.500-10	3.750	6.031	EY 6.3-4-781-1X■
1	1760	2.500-10	3.750	6.000	EY 6.3-4-781X■
1	1810	2.500-10	3.750	5.875	EY 6.5-4-3451■
1	1810	2.500-10	3.750	5.875	EY 6.5-4-3451-1■
1	1810	2.500-10	3.750	5.875	EY 6.5-4-3551-1X■
1	1810	2.500-10	3.750	5.875	EY 6.5-4-3551X■

M-13G9A-M13, M-13G10A-M13

1	SPL140	2.750-10	3.750	6.570	EY 140-4-81-1
1	SPL140	2.750-10	3.750	6.570	EY 140-4-91-1X
1	SPL170	2.750-10	3.750	5.850	EY 170-4-511-1
1	SPL170	2.750-10	3.750	5.850	EY 170-4-521-1X
1	SPL250	2.750-10	3.750	6.297	EY 250-4-231-1
1	SPL250	2.750-10	3.750	6.297	EY 250-4-241-1X
1	1710	2.750-10	3.750	5.750	EY 6-4-6821
1	1710	2.750-10	3.750	5.750	EY 6-4-6821-1
1	1710	2.750-10	3.750	5.750	EY 6-4-6931-1X
1	1710	2.750-10	3.750	5.750	EY 6-4-6931X
1	1760	2.750-10	3.750	5.969	EY 6.3-4-711
1	1760	2.750-10	3.750	5.969	EY 6.3-4-711-1■
1	1760	2.750-10	3.750	5.969	EY 6.3-4-791-1X
1	1760	2.750-10	3.750	5.969	EY 6.3-4-791X
1	1810	2.750-10	3.750	6.062	EY 6.5-4-3491
1	1810	2.750-10	3.750	6.062	EY 6.5-4-3491-1
1	1810	2.750-10	3.750	6.062	EY 6.5-4-3561-1X
1	1810	2.750-10	3.750	6.062	EY 6.5-4-3561X

M-13Z12A-A13, M-13Z16A-A13

1	SPL250	3.543-44	4.125	6.140	EY 250-4-921-1 <i>OEM only</i>
---	--------	----------	-------	-------	-----------------------------------

Pos	Series	Spline Data	Hub Dia	* to End of Hub	End Fitting Part Number
-----	--------	-------------	---------	-----------------	-------------------------

M-14G9A-M14, M-14G10A-M14

1	SPL140	2.750-10	3.750	6.570	EY 140-4-81-1
1	SPL140	2.750-10	3.750	6.570	EY 140-4-91-1X
1	SPL170	2.750-10	3.750	5.850	EY 170-4-511-1
1	SPL170	2.750-10	3.750	5.850	EY 170-4-521-1X
1	SPL250	2.750-10	3.750	6.297	EY 250-4-231-1
1	SPL250	2.750-10	3.750	6.297	EY 250-4-241-1X
1	1710	2.750-10	3.750	5.750	EY 6-4-6821
1	1710	2.750-10	3.750	5.750	EY 6-4-6821-1
1	1710	2.750-10	3.750	5.750	EY 6-4-6931-1X
1	1710	2.750-10	3.750	5.750	EY 6-4-6931X
1	1760	2.750-10	3.750	5.969	EY 6.3-4-711
1	1760	2.750-10	3.750	5.969	EY 6.3-4-711-1
1	1760	2.750-10	3.750	5.969	EY 6.3-4-791-1X
1	1760	2.750-10	3.750	5.969	EY 6.3-4-791X
1	1810	2.750-10	3.750	6.062	EY 6.5-4-3491
1	1810	2.750-10	3.750	6.062	EY 6.5-4-3491-1
1	1810	2.750-10	3.750	6.062	EY 6.5-4-3561-1X
1	1810	2.750-10	3.750	6.062	EY 6.5-4-3561X

M-14Z12A-A14, M-14Z16A-A14

1	SPL250	3.543-44	4.125	6.140	EY 250-4-921-1 <i>OEM only</i>
---	--------	----------	-------	-------	-----------------------------------

MO-11G10A-M11, MO-12G9A-M12, MO-12G10A-M12

1	SPL140	2.500-10	3.750	5.960	EY 140-4-41-1
1	SPL140	2.500-10	3.750	5.960	EY 140-4-51-1X
1	SPL170	2.500-10	3.750	5.750	EY 170-4-471-1■
1	SPL170	2.500-10	3.750	5.750	EY 170-4-481-1X■
1	SPL250	2.500-10	3.750	6.062	EY 250-4-191-1■
1	SPL250	2.500-10	3.750	6.062	EY 250-4-201-1X■
1	1710	2.500-10	3.750	5.625	EY 6-4-6611■
1	1710	2.500-10	3.750	5.625	EY 6-4-6611-1■
1	1710	2.500-10	3.750	5.625	EY 6-4-6921-1X■
1	1710	2.500-10	3.750	5.625	EY 6-4-6921X■
1	1760	2.500-10	3.750	6.000	EY 6.3-4-651
1	1760	2.500-10	3.750	6.031	EY 6.3-4-651-1■
1	1760	2.500-10	3.750	6.031	EY 6.3-4-781-1X■
1	1760	2.500-10	3.750	6.000	EY 6.3-4-781X■
1	1810	2.500-10	3.750	5.875	EY 6.5-4-3451■
1	1810	2.500-10	3.750	5.875	EY 6.5-4-3451-1■
1	1810	2.500-10	3.750	5.875	EY 6.5-4-3551-1X■
1	1810	2.500-10	3.750	5.875	EY 6.5-4-3551X■

*C/L to End of Hub for EY (End Yoke); Flange Face to End of Hub for CF (Companion Flange)

■ Hub machined for speedometer gear



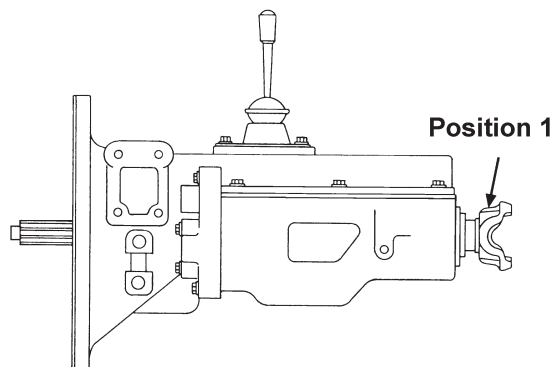

Pos	Series	Spline Data	Hub Dia	* to End of Hub	End Fitting Part Number
-----	--------	-------------	---------	-----------------	-------------------------

MO-13G9A-M13, MO-13G10A-M13

1	SPL140	2.750-10	3.750	6.570	EY 140-4-81-1
1	SPL140	2.750-10	3.750	6.570	EY 140-4-91-1X
1	SPL170	2.750-10	3.750	5.850	EY 170-4-511-1
1	SPL170	2.750-10	3.750	5.850	EY 170-4-521-1X
1	SPL250	2.750-10	3.750	6.297	EY 250-4-231-1
1	SPL250	2.750-10	3.750	6.297	EY 250-4-241-1X
1	1710	2.750-10	3.750	5.750	EY 6-4-6821
1	1710	2.750-10	3.750	5.750	EY 6-4-6821-1
1	1710	2.750-10	3.750	5.750	EY 6-4-6931-1X
1	1710	2.750-10	3.750	5.750	EY 6-4-6931X
1	1760	2.750-10	3.750	5.969	EY 6.3-4-711
1	1760	2.750-10	3.750	5.969	EY 6.3-4-711-1
1	1760	2.750-10	3.750	5.969	EY 6.3-4-791-1X
1	1760	2.750-10	3.750	5.969	EY 6.3-4-791X
1	1810	2.750-10	3.750	6.062	EY 6.5-4-3491
1	1810	2.750-10	3.750	6.062	EY 6.5-4-3491-1
1	1810	2.750-10	3.750	6.062	EY 6.5-4-3561-1X
1	1810	2.750-10	3.750	6.062	EY 6.5-4-3561X

MO-13Z12A-A13, MO-13Z16A-A13

1	SPL250	3.543-44	4.125	6.140	EY 250-4-921-1 <i>OEM only</i>
---	--------	----------	-------	-------	-----------------------------------

MO-14G9A-M14, MO-14G10A-M14

1	SPL140	2.750-10	3.750	6.570	EY 140-4-81-1
1	SPL140	2.750-10	3.750	6.570	EY 140-4-91-1X
1	SPL170	2.750-10	3.750	5.850	EY 170-4-511-1
1	SPL170	2.750-10	3.750	5.850	EY 170-4-521-1X
1	SPL250	2.750-10	3.750	6.297	EY 250-4-231-1
1	SPL250	2.750-10	3.750	6.297	EY 250-4-241-1X
1	1710	2.750-10	3.750	5.750	EY 6-4-6821
1	1710	2.750-10	3.750	5.750	EY 6-4-6821-1
1	1710	2.750-10	3.750	5.750	EY 6-4-6931-1X
1	1710	2.750-10	3.750	5.750	EY 6-4-6931X
1	1760	2.750-10	3.750	5.969	EY 6.3-4-711
1	1760	2.750-10	3.750	5.969	EY 6.3-4-711-1
1	1760	2.750-10	3.750	5.969	EY 6.3-4-791-1X
1	1760	2.750-10	3.750	5.969	EY 6.3-4-791X
1	1810	2.750-10	3.750	6.062	EY 6.5-4-3491
1	1810	2.750-10	3.750	6.062	EY 6.5-4-3491-1
1	1810	2.750-10	3.750	6.062	EY 6.5-4-3561-1X
1	1810	2.750-10	3.750	6.062	EY 6.5-4-3561X

MO-14Z12A-A14, MO-14Z16A-A14

1	SPL250	3.543-44	4.125	6.140	EY 250-4-921-1 <i>OEM only</i>
---	--------	----------	-------	-------	-----------------------------------

Pos	Series	Spline Data	Hub Dia	* to End of Hub	End Fitting Part Number
-----	--------	-------------	---------	-----------------	-------------------------

RM-9-115A, RM-9-125A

1	SPL140	2.500-10	3.750	5.960	EY 140-4-41-1
1	SPL140	2.500-10	3.750	5.960	EY 140-4-51-1X
1	SPL170	2.500-10	3.750	5.750	EY 170-4-471-1■
1	SPL170	2.500-10	3.750	5.750	EY 170-4-481-1X■
1	SPL250	2.500-10	3.750	6.062	EY 250-4-191-1■
1	SPL250	2.500-10	3.750	6.062	EY 250-4-201-1X■
1	1710	2.500-10	3.750	5.625	EY 6-4-6611■
1	1710	2.500-10	3.750	5.625	EY 6-4-6611-1■
1	1710	2.500-10	3.750	5.625	EY 6-4-6921-1X■
1	1710	2.500-10	3.750	5.625	EY 6-4-6921X■
1	1760	2.500-10	3.750	6.000	EY 6.3-4-651■
1	1760	2.500-10	3.750	6.031	EY 6.3-4-651-1■
1	1760	2.500-10	3.750	6.031	EY 6.3-4-781-1X■
1	1760	2.500-10	3.750	6.000	EY 6.3-4-781X■
1	1810	2.500-10	3.750	5.875	EY 6.5-4-3451■
1	1810	2.500-10	3.750	5.875	EY 6.5-4-3451-1■
1	1810	2.500-10	3.750	5.875	EY 6.5-4-3551-1X■
1	1810	2.500-10	3.750	5.875	EY 6.5-4-3551X■

RM-9-135A, RM-9-145A, RM-9-155A

1	SPL140	2.750-10	3.750	6.570	EY 140-4-81-1
1	SPL140	2.750-10	3.750	6.570	EY 140-4-91-1X
1	SPL170	2.750-10	3.750	5.850	EY 170-4-511-1
1	SPL170	2.750-10	3.750	5.850	EY 170-4-521-1X
1	SPL250	2.750-10	3.750	6.297	EY 250-4-231-1
1	SPL250	2.750-10	3.750	6.297	EY 250-4-241-1X
1	1710	2.750-10	3.750	5.750	EY 6-4-6821
1	1710	2.750-10	3.750	5.750	EY 6-4-6821-1
1	1710	2.750-10	3.750	5.750	EY 6-4-6931-1X
1	1710	2.750-10	3.750	5.750	EY 6-4-6931X
1	1760	2.750-10	3.750	5.969	EY 6.3-4-711
1	1760	2.750-10	3.750	5.969	EY 6.3-4-711-1
1	1760	2.750-10	3.750	5.969	EY 6.3-4-791-1X
1	1760	2.750-10	3.750	5.969	EY 6.3-4-791X
1	1810	2.750-10	3.750	6.062	EY 6.5-4-3491
1	1810	2.750-10	3.750	6.062	EY 6.5-4-3491-1
1	1810	2.750-10	3.750	6.062	EY 6.5-4-3561-1X
1	1810	2.750-10	3.750	6.062	EY 6.5-4-3561X

RM-9-1250

1	SPL170	2.500-10	3.750	5.750	EY 170-4-471-1■
1	SPL170	2.500-10	3.750	5.750	EY 170-4-481-1X■
1	SPL250	2.500-10	3.750	6.062	EY 250-4-191-1■
1	SPL250	2.500-10	3.750	6.062	EY 250-4-201-1X■
1	1710	2.500-10	3.750	5.625	EY 6-4-6611■

*C/L to End of Hub for EY (End Yoke); Flange Face to End of Hub for CF (Companion Flange)

■ Hub machined for speedometer gear



Pos	Series	Spline Data	Hub Dia	* to End of Hub	End Fitting Part Number
RM-9-1250 (Continued)					
1	1710	2.500-10	3.750	5.625	EY 6-4-6611-1■
1	1710	2.500-10	3.750	5.625	EY 6-4-6921-1X■
1	1710	2.500-10	3.750	5.625	EY 6-4-6921X■
1	1760	2.500-10	3.750	6.000	EY 6.3-4-651■
1	1760	2.500-10	3.750	6.031	EY 6.3-4-651-1■
1	1760	2.500-10	3.750	6.031	EY 6.3-4-781-1X■
1	1760	2.500-10	3.750	6.000	EY 6.3-4-781X■
1	1810	2.500-10	3.750	5.875	EY 6.5-4-3451■
1	1810	2.500-10	3.750	5.875	EY 6.5-4-3451-1■
1	1810	2.500-10	3.750	5.875	EY 6.5-4-3551-1X■
1	1810	2.500-10	3.750	5.875	EY 6.5-4-3551X■

RM-9-1450					
1	SPL140	2.750-10	3.750	6.570	EY 140-4-81-1
1	SPL140	2.750-10	3.750	6.570	EY 140-4-91-1X
1	SPL170	2.750-10	3.750	5.850	EY 170-4-511-1
1	SPL170	2.750-10	3.750	5.850	EY 170-4-521-1X
1	SPL250	2.750-10	3.750	6.297	EY 250-4-231-1
1	SPL250	2.750-10	3.750	6.297	EY 250-4-241-1X
1	1710	2.750-10	3.750	5.750	EY 6-4-6821
1	1710	2.750-10	3.750	5.750	EY 6-4-6821-1
1	1710	2.750-10	3.750	5.750	EY 6-4-6931-1X
1	1710	2.750-10	3.750	5.750	EY 6-4-6931X
1	1760	2.750-10	3.750	5.969	EY 6.3-4-711
1	1760	2.750-10	3.750	5.969	EY 6.3-4-711-1
1	1760	2.750-10	3.750	5.969	EY 6.3-4-791-1X
1	1760	2.750-10	3.750	5.969	EY 6.3-4-791X
1	1810	2.750-10	3.750	6.062	EY 6.5-4-3491
1	1810	2.750-10	3.750	6.062	EY 6.5-4-3491-1
1	1810	2.750-10	3.750	6.062	EY 6.5-4-3561-1X
1	1810	2.750-10	3.750	6.062	EY 6.5-4-3561X

RM-10-115A, RM-10-125A					
1	SPL140	2.500-10	3.750	5.960	EY 140-4-41-1
1	SPL140	2.500-10	3.750	5.960	EY 140-4-51-1X
1	SPL170	2.500-10	3.750	5.750	EY 170-4-471-1■
1	SPL170	2.500-10	3.750	5.750	EY 170-4-481-1X■
1	SPL250	2.500-10	3.750	6.062	EY 250-4-191-1■
1	SPL250	2.500-10	3.750	6.062	EY 250-4-201-1X■
1	1710	2.500-10	3.750	5.625	EY 6-4-6611■
1	1710	2.500-10	3.750	5.625	EY 6-4-6611-1■
1	1710	2.500-10	3.750	5.625	EY 6-4-6921-1X■
1	1710	2.500-10	3.750	5.625	EY 6-4-6921X■
1	1760	2.500-10	3.750	6.000	EY 6.3-4-651■
1	1760	2.500-10	3.750	6.031	EY 6.3-4-651-1■
1	1760	2.500-10	3.750	6.031	EY 6.3-4-781-1X■
1	1760	2.500-10	3.750	6.000	EY 6.3-4-781X■
1	1810	2.500-10	3.750	5.875	EY 6.5-4-3451■
1	1810	2.500-10	3.750	5.875	EY 6.5-4-3451-1■
1	1810	2.500-10	3.750	5.875	EY 6.5-4-3551-1X■
1	1810	2.500-10	3.750	5.875	EY 6.5-4-3551X■

RM-10-135A, RM-10-145A, RM-10-155A, RM-10-165					
1	SPL140	2.750-10	3.750	6.570	EY 140-4-81-1
1	SPL140	2.750-10	3.750	6.570	EY 140-4-91-1X
1	SPL170	2.750-10	3.750	5.850	EY 170-4-511-1
1	SPL170	2.750-10	3.750	5.850	EY 170-4-521-1X
1	SPL250	2.750-10	3.750	6.297	EY 250-4-231-1
1	SPL250	2.750-10	3.750	6.297	EY 250-4-241-1X
1	1710	2.750-10	3.750	5.750	EY 6-4-6821

Pos	Series	Spline Data	Hub Dia	* to End of Hub	End Fitting Part Number
RM-10-135A, RM-10-145A, RM-10-155A, RM-10-165 (Continued)					
1	1710	2.750-10	3.750	5.750	EY 6-4-6821-1
1	1710	2.750-10	3.750	5.750	EY 6-4-6931-1X
1	1710	2.750-10	3.750	5.750	EY 6-4-6931X
1	1760	2.750-10	3.750	5.969	EY 6.3-4-711
1	1760	2.750-10	3.750	5.969	EY 6.3-4-711-1
1	1760	2.750-10	3.750	5.969	EY 6.3-4-791-1X
1	1760	2.750-10	3.750	5.969	EY 6.3-4-791X
1	1810	2.750-10	3.750	6.062	EY 6.5-4-3491
1	1810	2.750-10	3.750	6.062	EY 6.5-4-3491-1
1	1810	2.750-10	3.750	6.062	EY 6.5-4-3561-1X
1	1810	2.750-10	3.750	6.062	EY 6.5-4-3561X

RM-10-1150, RM-10-1250					
1	SPL170	2.500-10	3.750	5.750	EY 170-4-471-1■
1	SPL170	2.500-10	3.750	5.750	EY 170-4-481-1X■
1	SPL250	2.500-10	3.750	6.062	EY 250-4-191-1■
1	SPL250	2.500-10	3.750	6.062	EY 250-4-201-1X■
1	1710	2.500-10	3.750	5.625	EY 6-4-6611■
1	1710	2.500-10	3.750	5.625	EY 6-4-6611-1■
1	1710	2.500-10	3.750	5.625	EY 6-4-6921-1X■
1	1710	2.500-10	3.750	5.625	EY 6-4-6921X■
1	1760	2.500-10	3.750	6.000	EY 6.3-4-651■
1	1760	2.500-10	3.750	6.031	EY 6.3-4-651-1■
1	1760	2.500-10	3.750	6.031	EY 6.3-4-781-1X■
1	1760	2.500-10	3.750	6.000	EY 6.3-4-781X■
1	1810	2.500-10	3.750	5.875	EY 6.5-4-3451■
1	1810	2.500-10	3.750	5.875	EY 6.5-4-3451-1■
1	1810	2.500-10	3.750	5.875	EY 6.5-4-3551-1X■
1	1810	2.500-10	3.750	5.875	EY 6.5-4-3551X■

RM-10-1350, RM-10-1450, RM-10-1550, RM-13-145A					
1	SPL140	2.750-10	3.750	6.570	EY 140-4-81-1
1	SPL140	2.750-10	3.750	6.570	EY 140-4-91-1X
1	SPL170	2.750-10	3.750	5.850	EY 170-4-511-1
1	SPL170	2.750-10	3.750	5.850	EY 170-4-521-1X
1	SPL250	2.750-10	3.750	6.297	EY 250-4-231-1
1	SPL250	2.750-10	3.750	6.297	EY 250-4-241-1X
1	1710	2.750-10	3.750	5.750	EY 6-4-6821
1	1710	2.750-10	3.750	5.750	EY 6-4-6821-1
1	1710	2.750-10	3.750	5.750	EY 6-4-6931-1X
1	1710	2.750-10	3.750	5.750	EY 6-4-6931X
1	1760	2.750-10	3.750	5.969	EY 6.3-4-711
1	1760	2.750-10	3.750	5.969	EY 6.3-4-711-1
1	1760	2.750-10	3.750	5.969	EY 6.3-4-791-1X
1	1760	2.750-10	3.750	5.969	EY 6.3-4-791X
1	1810	2.750-10	3.750	6.062	EY 6.5-4-3491
1	1810	2.750-10	3.750	6.062	EY 6.5-4-3491-1
1	1810	2.750-10	3.750	6.062	EY 6.5-4-3561-1X
1	1810	2.750-10	3.750	6.062	EY 6.5-4-3561X

RM-13-1450, RM-13-1550					
1	SPL140	2.750-10	3.750	6.570	EY 140-4-81-1
1	SPL140	2.750-10	3.750	6.570	EY 140-4-91-1X
1	SPL170	2.750-10	3.750	5.850	EY 170-4-511-1
1	SPL170	2.750-10	3.750	5.850	EY 170-4-521-1X
1	SPL250	2.750-10	3.750	6.297	EY 250-4-231-1
1	SPL250	2.750-10	3.750	6.297	EY 250-4-241-1X
1	1710	2.750-10	3.750	5.750	EY 6-4-6931-1X

Continued on next page

*C/L to End of Hub for EY (End Yoke); Flange Face to End of Hub for CF (Companion Flange)

■ Hub machined for speedometer gear



Important: See Safety Information in General Information Section (J300P-GI)

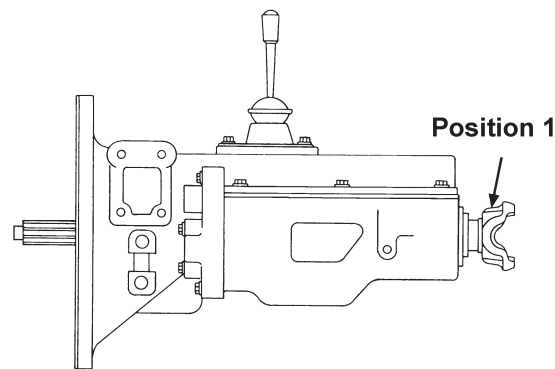

Pos	Series	Spline Data	Hub Dia	* to End of Hub	End Fitting Part Number
-----	--------	-------------	---------	-----------------	-------------------------

RM-13-1450, RM-13-1550 (Continued)

1	1710	2.750-10	3.750	5.750	EY 6-4-6931X
1	1760	2.750-10	3.750	5.969	EY 6.3-4-711
1	1760	2.750-10	3.750	5.969	EY 6.3-4-711-1
1	1760	2.750-10	3.750	5.969	EY 6.3-4-791-1X
1	1760	2.750-10	3.750	5.969	EY 6.3-4-791X
1	1810	2.750-10	3.750	6.062	EY 6.5-4-3491
1	1810	2.750-10	3.750	6.062	EY 6.5-4-3491-1
1	1810	2.750-10	3.750	6.062	EY 6.5-4-3561-1X
1	1810	2.750-10	3.750	6.062	EY 6.5-4-3561X

RMO-9-115A, RMO-9-125A, RMO-10-115A, RMO-10-125A

1	SPL140	2.500-10	3.750	5.960	EY 140-4-41-1
1	SPL140	2.500-10	3.750	5.960	EY 140-4-51-1X
1	SPL170	2.500-10	3.750	5.750	EY 170-4-471-1■
1	SPL170	2.500-10	3.750	5.750	EY 170-4-481-1X■
1	SPL250	2.500-10	3.750	6.062	EY 250-4-191-1■
1	SPL250	2.500-10	3.750	6.062	EY 250-4-201-1X■
1	1710	2.500-10	3.750	5.625	EY 6-4-6611■
1	1710	2.500-10	3.750	5.625	EY 6-4-6611-1■
1	1710	2.500-10	3.750	5.625	EY 6-4-6921-1X■
1	1710	2.500-10	3.750	5.625	EY 6-4-6921X■
1	1760	2.500-10	3.750	6.000	EY 6.3-4-651■
1	1760	2.500-10	3.750	6.031	EY 6.3-4-651-1■
1	1760	2.500-10	3.750	6.031	EY 6.3-4-781-1X■
1	1760	2.500-10	3.750	6.000	EY 6.3-4-781X■
1	1810	2.500-10	3.750	5.875	EY 6.5-4-3451■
1	1810	2.500-10	3.750	5.875	EY 6.5-4-3451-1■
1	1810	2.500-10	3.750	5.875	EY 6.5-4-3551-1X■
1	1810	2.500-10	3.750	5.875	EY 6.5-4-3551X■

RMO-12-145A

1	SPL140	2.750-10	3.750	6.570	EY 140-4-81-1
---	--------	----------	-------	-------	---------------

RM-13-145A, RMX-10-165A

1	SPL140	2.750-10	3.750	6.570	EY 140-4-91-1X
1	SPL170	2.750-10	3.750	5.850	EY 170-4-511-1
1	SPL170	2.750-10	3.750	5.850	EY 170-4-521-1X
1	SPL250	2.750-10	3.750	6.297	EY 250-4-231-1
1	SPL250	2.750-10	3.750	6.297	EY 250-4-241-1X
1	1710	2.750-10	3.750	5.750	EY 6-4-6821
1	1710	2.750-10	3.750	5.750	EY 6-4-6821-1
1	1710	2.750-10	3.750	5.750	EY 6-4-6931-1X
1	1710	2.750-10	3.750	5.750	EY 6-4-6931X
1	1760	2.750-10	3.750	5.969	EY 6.3-4-711
1	1760	2.750-10	3.750	5.969	EY 6.3-4-711-1

Pos	Series	Spline Data	Hub Dia	* to End of Hub	End Fitting Part Number
-----	--------	-------------	---------	-----------------	-------------------------

RMO-13-145A, RMX-10-165A (Continued)

1	1760	2.750-10	3.750	5.969	EY 6.3-4-791-1X
1	1760	2.750-10	3.750	5.969	EY 6.3-4-791X
1	1810	2.750-10	3.750	6.062	EY 6.5-4-3491
1	1810	2.750-10	3.750	6.062	EY 6.5-4-3491-1
1	1810	2.750-10	3.750	6.062	EY 6.5-4-3561-1X
1	1810	2.750-10	3.750	6.062	EY 6.5-4-3561X

RMX-13-145A

1	1760	2.750-10	3.750	5.969	EY 6.3-4-791X
---	------	----------	-------	-------	---------------

SPICER®

AMO1000-4, APO1000-4

1	SPL250	2.750-10	4.000	6.370	EY 250-4-551-1■
---	--------	----------	-------	-------	-----------------

ASO125-10, ASO140-10

1	1810	2.500-10	3.750	3.625	CF 6.5-1-2271
1	1810	2.500-10	3.750	3.625	CF 6.5-1-2351X
1	1710	2.500-10	3.750	5.625	EY 6-4-6611■
1	1710	2.500-10	3.750	5.625	EY 6-4-6611-1■
1	1760	2.500-10	3.750	6.000	EY 6.3-4-651■
1	1760	2.500-10	3.750	6.031	EY 6.3-4-651-1■
1	1810	2.500-10	3.750	5.875	EY 6.5-4-3451■
1	1810	2.500-10	3.750	5.875	EY 6.5-4-3451-1■

ASO150-10

1	1810	2.500-10	3.750	3.625	CF 6.5-1-2271
1	1810	2.500-10	3.750	3.625	CF 6.5-1-2351X
1	SPL250	2.500-10	3.750	6.250	EY 250-4-561-1■
1	1710	2.500-10	3.750	5.625	EY 6-4-6611■
1	1710	2.500-10	3.750	5.625	EY 6-4-6611-1■
1	1760	2.500-10	3.750	6.000	EY 6.3-4-651■
1	1760	2.500-10	3.750	6.031	EY 6.3-4-651-1■
1	1810	2.500-10	3.750	5.875	EY 6.5-4-3451■
1	1810	2.500-10	3.750	5.875	EY 6.5-4-3451-1■

ASO165-10

1	1810	2.500-10	3.750	3.625	CF 6.5-1-2271
1	1810	2.500-10	3.750	3.625	CF 6.5-1-2351X
1	1710	2.500-10	3.750	5.625	EY 6-4-6611■
1	1710	2.500-10	3.750	5.625	EY 6-4-6611-1■
1	1760	2.500-10	3.750	6.000	EY 6.3-4-651■
1	1760	2.500-10	3.750	6.031	EY 6.3-4-651-1■
1	1810	2.500-10	3.750	5.875	EY 6.5-4-3451■
1	1810	2.500-10	3.750	5.875	EY 6.5-4-3451-1■

*C/L to End of Hub for EY (End Yoke); Flange Face to End of Hub for CF (Companion Flange)

■ Hub machined for speedometer gear



Pos	Series	Spline Data	Hub Dia	* to End of Hub	End Fitting Part Number
ATO1000-4					
1	SPL250	2.750-10	4.000	6.370	EY 250-4-551-1■
CM40, CM49					
1	1610	1.998-38	2.750	4.688	CF 5-1-6271 <i>Can be used w/brake</i>
1	SPL140	1.998-38	2.750	7.728	EY 140-4-1021-1 <i>Flanged end yoke.</i>
1	SPL140	1.998-38	2.750	4.830	EY 140-4-111-1 <i>Can be used w/brake</i>
1	SPL140	1.998-38	2.750	4.730	EY 140-4-891-1
1	SPL170	1.998-38	2.750	4.844	EY 170-4-541-1
1	SPL90	1.998-38	2.750	7.562	EY 90-4-111-1 <i>Can be used w/brake; Flanged end yoke.</i>
1	SPL90	1.998-38	2.750	4.250	EY 90-4-391-1 <i>Can be used w/brake</i>
1	SPL90	1.998-38	2.750	4.000	EY 90-4-71-1 <i>Can be used w/brake</i>
1	1550	1.998-38	2.750	4.035	EY 4-4-4491-1 <i>S/A 4-4-7341-1 But Hub does not Include Slinger Diameter</i>
1	1550	1.998-38	2.750	4.156	EY 4-4-4611
1	1550	1.998-38	2.750	4.156	EY 4-4-4611-1
1	1550	1.998-38	2.750	4.156	EY 4-4-4611-2 <i>Attaching hardware by OEM</i>
1	1550	1.998-38	2.750	7.031	EY 4-4-6101-1 <i>Can be used w/brake; Flanged end yoke.</i>
1	1610	1.998-38	2.750	4.125	EY 5-4-6321
1	1610	1.998-38	2.750	4.000	EY 5-4-6321-1
1	1610	1.998-38	2.750	4.156	EY 5-4-6481
1	1610	1.998-38	2.750	4.156	EY 5-4-6481-1
1	1610	1.998-38	2.750	7.562	EY 5-4-7601-1 <i>Flanged end yoke.</i>
1	1710	1.998-38	2.750	5.250	EY 6-4-7301
1	1710	1.998-38	2.750	5.250	EY 6-4-7301-1
CM50					
1	1480/1550	1.750-10	2.500	3.000	CF 4-1-3891
1	1610	1.750-10	2.500	4.250	EY 5-4-1051
CM55					
1	1610	1.998-38	2.750	4.688	CF 5-1-6271 <i>Can be used w/brake</i>
1	SPL140	1.998-38	2.750	7.728	EY 140-4-1021-1 <i>Flanged end yoke.</i>
1	SPL140	1.998-38	2.750	4.830	EY 140-4-111-1
1	SPL140	1.998-38	2.750	4.730	EY 140-4-891-1
1	SPL170	1.998-38	2.750	4.844	EY 170-4-541-1
1	SPL90	1.998-38	2.750	7.562	EY 90-4-111-1 <i>Can be used w/brake; Flanged end yoke.</i>
1	SPL90	1.998-38	2.750	4.250	EY 90-4-391-1
1	SPL90	1.998-38	2.750	4.000	EY 90-4-71-1
1	1550	1.998-38	2.750	4.035	EY 4-4-4491-1 <i>S/A 4-4-7341-1 But Hub does not Include Slinger Diameter</i>
1	1550	1.998-38	2.750	4.156	EY 4-4-4611
1	1550	1.998-38	2.750	4.156	EY 4-4-4611-1
1	1550	1.998-38	2.750	4.156	EY 4-4-4611-2 <i>Attaching hardware by OEM</i>
1	1550	1.998-38	2.750	7.031	EY 4-4-6101-1 <i>Can be used w/brake; Flanged end yoke.</i>
1	1610	1.998-38	2.750	4.125	EY 5-4-6321
1	1610	1.998-38	2.750	4.000	EY 5-4-6321-1
1	1610	1.998-38	2.750	4.156	EY 5-4-6481
1	1610	1.998-38	2.750	4.156	EY 5-4-6481-1
1	1610	1.998-38	2.750	7.562	EY 5-4-7601-1 <i>Flanged end yoke.</i>
1	1710	1.998-38	2.750	5.250	EY 6-4-7301
1	1710	1.998-38	2.750	5.250	EY 6-4-7301-1

Pos	Series	Spline Data	Hub Dia	* to End of Hub	End Fitting Part Number
CM59					
1	1610	1.998-38	2.750	4.688	CF 5-1-6271 <i>Can be used w/brake</i>
1	SPL140	1.998-38	2.750	4.830	EY 140-4-111-1
1	SPL140	1.998-38	2.750	4.730	EY 140-4-891-1
1	SPL170	1.998-38	2.750	4.844	EY 170-4-541-1
1	SPL90	1.998-38	2.750	7.562	EY 90-4-111-1 <i>Can be used w/brake; Flanged end yoke.</i>
1	SPL90	1.998-38	2.750	4.250	EY 90-4-391-1
1	SPL90	1.998-38	2.750	4.000	EY 90-4-71-1
1	1550	1.998-38	2.750	4.035	EY 4-4-4491-1 <i>S/A 4-4-7341-1 But Hub does not Include Slinger Diameter</i>
1	1550	1.998-38	2.750	4.156	EY 4-4-4611
1	1550	1.998-38	2.750	4.156	EY 4-4-4611-1
1	1550	1.998-38	2.750	4.156	EY 4-4-4611-2 <i>Attaching hardware by OEM</i>
1	1550	1.998-38	2.750	7.031	EY 4-4-6101-1 <i>Can be used w/brake; Flanged end yoke.</i>
1	1610	1.998-38	2.750	4.125	EY 5-4-6321
1	1610	1.998-38	2.750	4.000	EY 5-4-6321-1
1	1610	1.998-38	2.750	4.156	EY 5-4-6481
1	1610	1.998-38	2.750	4.156	EY 5-4-6481-1
1	1610	1.998-38	2.750	7.562	EY 5-4-7601-1 <i>Can be used w/brake; Flanged end yoke.</i>
1	1710	1.998-38	2.750	5.250	EY 6-4-7301
1	1710	1.998-38	2.750	5.250	EY 6-4-7301-1
CM60					
1	SPL90	2.000-10	2.750	4.969	EY 90-4-21-1
1	1550	2.000-10	2.750	3.625	CF 4-1-3781
1	1610	2.000-10	2.750	3.625	CF 5-1-3141
1	1710	2.000-10	2.750	3.688	CF 6-1-2221
1	1610	2.000-10	2.750	5.188	EY 5-4-1661
1	1610	2.000-10	2.750	5.469	EY 5-4-1661-1
1	1610	1.962-10	2.750	5.281	EY 5-4-7041-1
1	1710	1.962-10	2.750	5.156	EY 6-4-3831
1	1710	1.962-10	2.750	5.156	EY 6-4-3831-1
ESO65-7					
1	1610	1.998-38	2.750	4.688	CF 5-1-6271 <i>Assy includes eight 6-73-725 bolts</i>
1	SPL140	1.998-38	2.750	4.830	EY 140-4-111-1
1	SPL170	1.998-38	2.750	4.844	EY 170-4-541-1
1	SPL90	1.998-38	2.750	7.562	EY 90-4-111-1 <i>Can be used w/brake; Flanged end yoke.</i>
1	SPL90	1.998-38	2.750	4.250	EY 90-4-391-1
1	SPL90	1.998-38	2.750	4.000	EY 90-4-71-1
1	1550	1.998-38	2.750	4.035	EY 4-4-4491-1 <i>S/A 4-4-7341-1 But Hub does not Include Slinger Diameter</i>
1	1550	1.998-38	2.750	4.156	EY 4-4-4611
1	1550	1.998-38	2.750	4.156	EY 4-4-4611-1
1	1550	1.998-38	2.750	4.156	EY 4-4-4611-2 <i>Attaching hardware by OEM</i>
1	1550	1.998-38	2.750	7.031	EY 4-4-6101-1 <i>Flanged end yoke.</i>
1	1610	1.998-38	2.750	4.125	EY 5-4-6321
1	1610	1.998-38	2.750	4.000	EY 5-4-6321-1
1	1610	1.998-38	2.750	4.156	EY 5-4-6481
1	1610	1.998-38	2.750	4.156	EY 5-4-6481-1
1	1610	1.998-38	2.750	7.562	EY 5-4-7601-1 <i>Flanged end yoke.</i>
1	1710	1.998-38	2.750	5.250	EY 6-4-7301
1	1710	1.998-38	2.750	5.250	EY 6-4-7301-1

*C/L to End of Hub for EY (End Yoke); Flange Face to End of Hub for CF (Companion Flange)

■ Hub machined for speedometer gear



Important: See Safety Information in General Information Section (J300P-GI)

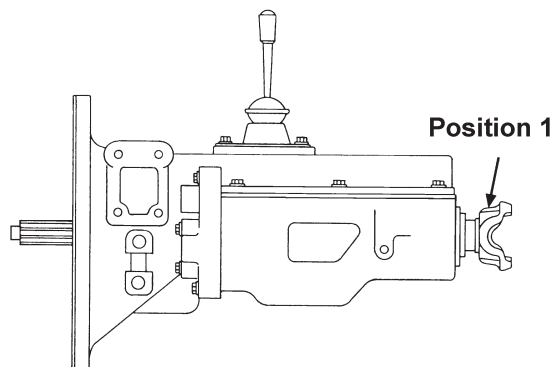

Pos	Series	Spline Data	Hub Dia	* to End of Hub	End Fitting Part Number
-----	--------	-------------	---------	-----------------	-------------------------

ESO66-7

1	1550	1.998-38	2.750	4.035	EY 4-4-4491-1 <i>S/A 4-4-7341-1 But Hub does not Include Slinger Diameter</i>
1	1550	1.998-38	2.750	4.156	EY 4-4-4611
1	1550	1.998-38	2.750	4.156	EY 4-4-4611-1
1	1550	1.998-38	2.750	4.156	EY 4-4-4611-2 <i>Attaching hardware by OEM</i>
1	1610	1.998-38	2.750	4.125	EY 5-4-6321
1	1610	1.998-38	2.750	4.000	EY 5-4-6321-1
1	1610	1.998-38	2.750	4.156	EY 5-4-6481
1	1610	1.998-38	2.750	4.156	EY 5-4-6481-1
1	1610	1.998-38	2.750	5.250	EY 6-4-7301
1	1610	1.998-38	2.750	5.250	EY 6-4-7301-1

ES42-5

1	1610	1.998-38	2.750	4.688	CF 5-1-6271
1	SPL140	1.998-38	2.750	4.730	EY 140-4-891-1
1	SPL170	1.998-38	2.750	4.844	EY 170-4-541-1
1	SPL90	1.998-38	2.750	7.562	EY 90-4-111-1 <i>Can be used w/brake; Flanged end yoke.</i>
1	SPL90	1.998-38	2.750	4.250	EY 90-4-391-1
1	SPL90	1.998-38	2.750	4.000	EY 90-4-71-1
1	1550	1.998-38	2.750	4.035	EY 4-4-4491-1 <i>S/A 4-4-7341-1 But Hub does not Include Slinger Diameter</i>
1	1550	1.998-38	2.750	4.156	EY 4-4-4611
1	1550	1.998-38	2.750	4.156	EY 4-4-4611-1
1	1550	1.998-38	2.750	4.156	EY 4-4-4611-2 <i>Attaching hardware by OEM</i>
1	1550	1.998-38	2.750	7.031	EY 4-4-6101-1 <i>Flanged end yoke.</i>
1	1610	1.998-38	2.750	4.125	EY 5-4-6321
1	1610	1.998-38	2.750	4.000	EY 5-4-6321-1
1	1610	1.998-38	2.750	4.156	EY 5-4-6481
1	1610	1.998-38	2.750	4.156	EY 5-4-6481-1
1	1610	1.998-38	2.750	7.562	EY 5-4-7601-1 <i>Flanged end yoke.</i>
1	1710	1.998-38	2.750	5.250	EY 6-4-7301
1	1710	1.998-38	2.750	5.250	EY 6-4-7301-1

ES43-5

1	1610	1.998-38	2.750	4.688	CF 5-1-6271
1	SPL140	1.998-38	2.750	4.830	EY 140-4-111-1
1	SPL140	1.998-38	2.750	4.730	EY 140-4-891-1
1	SPL170	1.998-38	2.750	4.844	EY 170-4-541-1
1	SPL90	1.998-38	2.750	7.562	EY 90-4-111-1 <i>Can be used w/brake; Flanged end yoke.</i>
1	SPL90	1.998-38	2.750	4.250	EY 90-4-391-1
1	SPL90	1.998-38	2.750	4.000	EY 90-4-71-1

Pos	Series	Spline Data	Hub Dia	* to End of Hub	End Fitting Part Number
-----	--------	-------------	---------	-----------------	-------------------------

ES43-5 (Continued)

1	1550	1.998-38	2.750	4.035	EY 4-4-4491-1 <i>S/A 4-4-7341-1 But Hub does not Include Slinger Diameter</i>
1	1550	1.998-38	2.750	7.031	EY 4-4-6101-1 <i>Flanged end yoke.</i>
1	1610	1.998-38	2.750	4.125	EY 5-4-6321
1	1610	1.998-38	2.750	4.000	EY 5-4-6321-1
1	1610	1.998-38	2.750	4.156	EY 5-4-6481
1	1610	1.998-38	2.750	4.156	EY 5-4-6481-1
1	1610	1.998-38	2.750	7.562	EY 5-4-7601-1 <i>Flanged end yoke.</i>
1	1710	1.998-38	2.750	5.250	EY 6-4-7301
1	1710	1.998-38	2.750	5.250	EY 6-4-7301-1

ES49-5

1	1480/1550	1.998-38	2.750	2.875	CF 4-1-5021
1	1480/1550	1.998-38	2.750	3.875	CF 4-1-6051X <i>Can be used w/brake</i>
1	1550	1.998-38	2.750	4.035	EY 4-4-4491-1 <i>S/A 4-4-7341-1 But Hub does not Include Slinger Diameter</i>
1	1550	1.998-38	2.750	4.156	EY 4-4-4611
1	1550	1.998-38	2.750	4.156	EY 4-4-4611-1
1	1550	1.998-38	2.750	4.156	EY 4-4-4611-2 <i>Attaching hardware by OEM</i>
1	1610	1.998-38	2.750	4.125	EY 5-4-6321
1	1610	1.998-38	2.750	4.000	EY 5-4-6321-1
1	1610	1.998-38	2.750	4.156	EY 5-4-6481
1	1610	1.998-38	2.750	4.156	EY 5-4-6481-1
1	1710	1.998-38	2.750	5.250	EY 6-4-7301
1	1710	1.998-38	2.750	5.250	EY 6-4-7301-1

ES52-5

1	1480/1550	1.998-38	2.750	2.875	CF 4-1-5021
1	1480/1550	1.998-38	2.750	3.875	CF 4-1-6051X <i>Can be used w/brake; Assy includes four 8-73-226 studs</i>
1	1610	1.998-38	2.750	4.688	CF 5-1-6271
1	SPL140	1.998-38	2.750	4.830	EY 140-4-111-1
1	SPL140	1.998-38	2.750	4.730	EY 140-4-891-1
1	SPL170	1.998-38	2.750	4.844	EY 170-4-541-1
1	SPL90	1.998-38	2.750	7.562	EY 90-4-111-1 <i>Can be used w/brake; Flanged end yoke.</i>
1	SPL90	1.998-38	2.750	4.250	EY 90-4-391-1
1	SPL90	1.998-38	2.750	4.000	EY 90-4-71-1
1	1550	1.998-38	2.750	4.035	EY 4-4-4491-1 <i>S/A 4-4-7341-1 But Hub does not Include Slinger Diameter</i>
1	1550	1.998-38	2.750	4.156	EY 4-4-4611
1	1550	1.998-38	2.750	4.156	EY 4-4-4611-1
1	1550	1.998-38	2.750	4.156	EY 4-4-4611-2 <i>Attaching hardware by OEM</i>

*C/L to End of Hub for EY (End Yoke); Flange Face to End of Hub for CF (Companion Flange)

■ Hub machined for speedometer gear



Pos	Series	Spline Data	Hub Dia	* to End of Hub	End Fitting Part Number
ES52-5 (Continued)					
1	1550	1.998-38	2.750	7.031	EY 4-4-6101-1 <i>Flanged end yoke.</i>
1	1610	1.998-38	2.750	4.125	EY 5-4-6321
1	1610	1.998-38	2.750	4.000	EY 5-4-6321-1
1	1610	1.998-38	2.750	4.156	EY 5-4-6481
1	1610	1.998-38	2.750	4.156	EY 5-4-6481-1
1	1610	1.998-38	2.750	7.562	EY 5-4-7601-1 <i>Flanged end yoke.</i>
1	1710	1.998-38	2.750	5.250	EY 6-4-7301
1	1710	1.998-38	2.750	5.250	EY 6-4-7301-1

Pos	Series	Spline Data	Hub Dia	* to End of Hub	End Fitting Part Number
ES52-7					
1	1610	1.998-38	2.750	4.688	CF 5-1-6271
1	SPL140	1.998-38	2.750	4.830	EY 140-4-111-1
1	SPL140	1.998-38	2.750	4.730	EY 140-4-891-1
1	SPL170	1.998-38	2.750	4.844	EY 170-4-541-1
1	SPL90	1.998-38	2.750	7.562	EY 90-4-111-1 <i>Can be used w/brake; Flanged end yoke.</i>
1	SPL90	1.998-38	2.750	4.250	EY 90-4-391-1
1	SPL90	1.998-38	2.750	4.000	EY 90-4-71-1
1	1550	1.998-38	2.750	4.035	EY 4-4-4491-1 <i>S/A 4-4-7341-1 But Hub does not Include Slinger Diameter</i>
1	1550	1.998-38	2.750	4.156	EY 4-4-4611
1	1550	1.998-38	2.750	4.156	EY 4-4-4611-1
1	1550	1.998-38	2.750	4.156	EY 4-4-4611-2 <i>Attaching hardware by OEM</i>
1	1550	1.998-38	2.750	7.031	EY 4-4-6101-1 <i>Flanged end yoke.</i>
1	1610	1.998-38	2.750	4.125	EY 5-4-6321
1	1610	1.998-38	2.750	4.000	EY 5-4-6321-1
1	1610	1.998-38	2.750	4.156	EY 5-4-6481
1	1610	1.998-38	2.750	4.156	EY 5-4-6481-1
1	1610	1.998-38	2.750	7.562	EY 5-4-7601-1 <i>Flanged end yoke.</i>
1	1710	1.998-38	2.750	5.250	EY 6-4-7301
1	1710	1.998-38	2.750	5.250	EY 6-4-7301-1

Pos	Series	Spline Data	Hub Dia	* to End of Hub	End Fitting Part Number
ES53-5					
1	1610	1.998-38	2.750	4.688	CF 5-1-6271
1	SPL140	1.998-38	2.750	4.830	EY 140-4-111-1
1	SPL140	1.998-38	2.750	4.730	EY 140-4-891-1
1	SPL170	1.998-38	2.750	4.844	EY 170-4-541-1
1	SPL90	1.998-38	2.750	7.562	EY 90-4-111-1 <i>Can be used w/brake; Flanged end yoke.</i>
1	SPL90	1.998-38	2.750	4.250	EY 90-4-391-1
1	SPL90	1.998-38	2.750	4.000	EY 90-4-71-1
1	1550	1.998-38	2.750	4.035	EY 4-4-4491-1 <i>S/A 4-4-7341-1 But Hub does not Include Slinger Diameter</i>
1	1550	1.998-38	2.750	7.031	EY 4-4-6101-1 <i>Flanged end yoke.</i>
1	1610	1.998-38	2.750	4.125	EY 5-4-6321
1	1610	1.998-38	2.750	4.000	EY 5-4-6321-1
1	1610	1.998-38	2.750	4.156	EY 5-4-6481
1	1610	1.998-38	2.750	4.156	EY 5-4-6481-1
1	1610	1.998-38	2.750	7.562	EY 5-4-7601-1 <i>Flanged end yoke.</i>
1	1710	1.998-38	2.750	5.250	EY 6-4-7301
1	1710	1.998-38	2.750	5.250	EY 6-4-7301-1

Pos	Series	Spline Data	Hub Dia	* to End of Hub	End Fitting Part Number
ES60-5					
1	1610	1.998-38	2.750	4.688	CF 5-1-6271
1	SPL140	1.998-38	2.750	4.830	EY 140-4-111-1

Pos	Series	Spline Data	Hub Dia	* to End of Hub	End Fitting Part Number
ES60-5 (Continued)					
1	SPL140	1.998-38	2.750	4.730	EY 140-4-891-1
1	SPL170	1.998-38	2.750	4.844	EY 170-4-541-1
1	SPL90	1.998-38	2.750	7.562	EY 90-4-111-1 <i>Can be used w/brake; Flanged end yoke.</i>
1	SPL90	1.998-38	2.750	4.250	EY 90-4-391-1
1	SPL90	1.998-38	2.750	4.000	EY 90-4-71-1
1	1550	1.998-38	2.750	4.035	EY 4-4-4491-1 <i>S/A 4-4-7341-1 But Hub does not Include Slinger Diameter</i>
1	1550	1.998-38	2.750	4.156	EY 4-4-4611
1	1550	1.998-38	2.750	4.156	EY 4-4-4611-1
1	1550	1.998-38	2.750	4.156	EY 4-4-4611-2 <i>Attaching hardware by OEM</i>
1	1550	1.998-38	2.750	7.031	EY 4-4-6101-1 <i>Flanged end yoke.</i>
1	1610	1.998-38	2.750	4.125	EY 5-4-6321
1	1610	1.998-38	2.750	4.000	EY 5-4-6321-1
1	1610	1.998-38	2.750	4.156	EY 5-4-6481
1	1610	1.998-38	2.750	4.156	EY 5-4-6481-1
1	1610	1.998-38	2.750	7.562	EY 5-4-7601-1 <i>Flanged end yoke.</i>
1	1710	1.998-38	2.750	5.250	EY 6-4-7301
1	1710	1.998-38	2.750	5.250	EY 6-4-7301-1

Pos	Series	Spline Data	Hub Dia	* to End of Hub	End Fitting Part Number
ES62-5					
1	1480/1550	1.998-38	2.750	3.875	CF 4-1-6051X <i>Can be used w/brake; Assy includes four 8-73-226 studs</i>
1	1610	1.998-38	2.750	4.688	CF 5-1-6271
1	SPL140	1.998-38	2.750	4.830	EY 140-4-111-1
1	SPL140	1.998-38	2.750	4.730	EY 140-4-891-1
1	SPL170	1.998-38	2.750	4.844	EY 170-4-541-1
1	SPL90	1.998-38	2.750	7.562	EY 90-4-111-1 <i>Can be used w/brake; Flanged end yoke.</i>
1	SPL90	1.998-38	2.750	4.250	EY 90-4-391-1
1	SPL90	1.998-38	2.750	4.000	EY 90-4-71-1
1	1550	1.998-38	2.750	4.035	EY 4-4-4491-1 <i>S/A 4-4-7341-1 But Hub does not Include Slinger Diameter</i>
1	1550	1.998-38	2.750	7.031	EY 4-4-6101-1 <i>Flanged end yoke.</i>
1	1610	1.998-38	2.750	4.125	EY 5-4-6321
1	1610	1.998-38	2.750	4.000	EY 5-4-6321-1
1	1610	1.998-38	2.750	4.156	EY 5-4-6481
1	1610	1.998-38	2.750	4.156	EY 5-4-6481-1
1	1610	1.998-38	2.750	7.562	EY 5-4-7601-1 <i>Flanged end yoke.</i>
1	1710	1.998-38	2.750	5.250	EY 6-4-7301
1	1710	1.998-38	2.750	5.250	EY 6-4-7301-1

Pos	Series	Spline Data	Hub Dia	* to End of Hub	End Fitting Part Number
ES65-5					
1	1480/1550	2.000-10	2.750	3.625	CF 4-1-3781
1	1610	2.000-10	2.750	3.625	CF 5-1-3141
1	1710	2.000-10	2.750	3.688	CF 6-1-2221
1	1610	2.000-10	2.750	5.188	EY 5-4-1661 <i>Can be used w/brake</i>
1	1610	2.000-10	2.750	5.469	EY 5-4-1661-1 <i>Can be used w/brake</i>
1	1610	1.962-10	2.750	5.281	EY 5-4-7041-1 <i>Can be used w/brake</i>
1	1710	1.962-10	2.750	5.156	EY 6-4-3831 <i>Can be used w/brake</i>
1	1710	1.962-10	2.750	5.156	EY 6-4-3831-1 <i>Can be used w/brake</i>

*C/L to End of Hub for EY (End Yoke); Flange Face to End of Hub for CF (Companion Flange)

■ Hub machined for speedometer gear



Important: See Safety Information in General Information Section (J300P-GI)

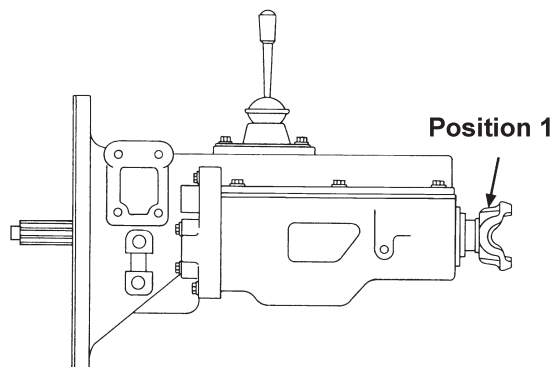

Pos	Series	Spline Data	Hub Dia	* to End of Hub	End Fitting Part Number
-----	--------	-------------	---------	-----------------	-------------------------

ES65-7

1	SPL140	1.998-38	2.750	4.730	EY 140-4-891-1
1	1610	1.998-38	2.750	4.156	EY 5-4-6481
1	1610	1.998-38	2.750	4.156	EY 5-4-6481-1
1	1610	1.998-38	2.750	7.562	EY 5-4-7601-1 <i>Flanged end yoke.</i>

ES66-7

1	1610	1.998-38	2.750	4.688	CF 5-1-6271
1	SPL140	1.998-38	2.750	4.830	EY 140-4-111-1
1	SPL170	1.998-38	2.750	4.844	EY 170-4-541-1
1	SPL90	1.998-38	2.750	7.562	EY 90-4-111-1 <i>Can be used w/brake; Flanged end yoke.</i>
1	SPL90	1.998-38	2.750	4.250	EY 90-4-391-1
1	SPL90	1.998-38	2.750	4.000	EY 90-4-71-1
1	1550	1.998-38	2.750	4.035	EY 4-4-4491-1
1	1550	1.998-38	2.750	7.031	EY 4-4-6101-1 <i>S/A 4-4-7341-1 But Hub does not Include Slinger Diameter Flanged end yoke.</i>
1	1610	1.998-38	2.750	4.125	EY 5-4-6321
1	1610	1.998-38	2.750	4.000	EY 5-4-6321-1
1	1610	1.998-38	2.750	4.156	EY 5-4-6481
1	1610	1.998-38	2.750	4.156	EY 5-4-6481-1
1	1610	1.998-38	2.750	7.562	EY 5-4-7601-1 <i>Flanged end yoke.</i>
1	1710	1.998-38	2.750	5.250	EY 6-4-7301
1	1710	1.998-38	2.750	5.250	EY 6-4-7301-1

ES67-5

1	1480/1550	1.998-38	2.750	3.875	CF 4-1-6051X <i>Can be used w/brake; Assy includes four 8-73-226 studs</i>
1	1610	1.998-38	2.750	4.688	CF 5-1-6271
1	SPL140	1.998-38	2.750	4.830	EY 140-4-111-1
1	SPL170	1.998-38	2.750	4.844	EY 170-4-541-1
1	SPL90	1.998-38	2.750	7.562	EY 90-4-111-1 <i>Can be used w/brake; Flanged end yoke.</i>
1	SPL90	1.998-38	2.750	4.250	EY 90-4-391-1
1	SPL90	1.998-38	2.750	4.000	EY 90-4-71-1
1	1550	1.998-38	2.750	4.035	EY 4-4-4491-1
1	1550	1.998-38	2.750	7.031	EY 4-4-6101-1 <i>Can be used w/brake; S/A 4-4-7341-1 But Hub does not Include Slinger Diameter Flanged end yoke.</i>
1	1610	1.998-38	2.750	4.125	EY 5-4-6321 <i>Can be used w/brake</i>
1	1610	1.998-38	2.750	4.000	EY 5-4-6321-1 <i>Can be used w/brake</i>
1	1610	1.998-38	2.750	4.156	EY 5-4-6481 <i>Can be used w/brake</i>

Pos	Series	Spline Data	Hub Dia	* to End of Hub	End Fitting Part Number
-----	--------	-------------	---------	-----------------	-------------------------

ES67-5 (Continued)

1	1610	1.998-38	2.750	4.156	EY 5-4-6481-1 <i>Can be used w/brake</i>
1	1610	1.998-38	2.750	7.562	EY 5-4-7601-1 <i>Flanged end yoke.</i>
1	1710	1.998-38	2.750	5.250	EY 6-4-7301 <i>Can be used w/brake</i>
1	1710	1.998-38	2.750	5.250	EY 6-4-7301-1 <i>Can be used w/brake</i>

ES70-5

1	1550	2.000-10	2.750	3.625	CF 4-1-3781 <i>Can be used w/brake</i>
1	1610	2.000-10	2.750	3.625	CF 5-1-3141 <i>Can be used w/brake</i>
1	1710	2.000-10	2.750	3.688	CF 6-1-2221 <i>Can be used w/brake</i>
1	1610	2.000-10	2.750	5.188	EY 5-4-1661 <i>Can be used w/brake</i>
1	1610	2.000-10	2.750	5.469	EY 5-4-1661-1 <i>Can be used w/brake</i>
1	1610	1.962-10	2.750	5.281	EY 5-4-7041-1 <i>Can be used w/brake</i>
1	1710	1.962-10	2.750	5.156	EY 6-4-3831 <i>Can be used w/brake</i>
1	1710	1.962-10	2.750	5.156	EY 6-4-3831-1 <i>Can be used w/brake</i>

LPSO125-10

1	1810	2.500-10	3.750	3.625	CF 6.5-1-2271
1	1810	2.500-10	3.750	3.625	CF 6.5-1-2351X
1	SPL250	2.500-10	3.750	6.250	EY 250-4-561-1■
1	1710	2.500-10	3.750	5.625	EY 6-4-6611■
1	1710	2.500-10	3.750	5.625	EY 6-4-6611-1■
1	1710	2.500-10	3.750	5.625	EY 6-4-6921-1X■
1	1710	2.500-10	3.750	5.625	EY 6-4-6921X■
1	1760	2.500-10	3.750	6.000	EY 6.3-4-651■
1	1760	2.500-10	3.750	6.031	EY 6.3-4-651-1■
1	1760	2.500-10	3.750	6.031	EY 6.3-4-781-1X■
1	1760	2.500-10	3.750	6.000	EY 6.3-4-781X■
1	1810	2.500-10	3.750	5.875	EY 6.5-4-3451■
1	1810	2.500-10	3.750	5.875	EY 6.5-4-3451-1■
1	1810	2.500-10	3.750	5.875	EY 6.5-4-3551-1X■
1	1810	2.500-10	3.750	5.875	EY 6.5-4-3551X■

LPSO140-10

1	1710	2.500-10	3.750	3.625	CF 6-1-5541
1	1810	2.500-10	3.750	3.625	CF 6.5-1-2271
1	1810	2.500-10	3.750	3.625	CF 6.5-1-2351X

*C/L to End of Hub for EY (End Yoke); Flange Face to End of Hub for CF (Companion Flange)

■ Hub machined for speedometer gear



Pos	Series	Spline Data	Hub Dia	* to End of Hub	End Fitting Part Number
LPSO140-10 (Continued)					
1	SPL250	2.500-10	3.750	6.250	EY 250-4-561-1■
1	1710	2.500-10	3.750	5.625	EY 6-4-6611■
1	1710	2.500-10	3.750	5.625	EY 6-4-6611-1■
1	1710	2.500-10	3.750	5.625	EY 6-4-6921-1X■
1	1710	2.500-10	3.750	5.625	EY 6-4-6921X■
1	1760	2.500-10	3.750	6.000	EY 6.3-4-651■
1	1760	2.500-10	3.750	6.031	EY 6.3-4-651-1■
1	1760	2.500-10	3.750	6.031	EY 6.3-4-781-1X■
1	1760	2.500-10	3.750	6.000	EY 6.3-4-781X■
1	1810	2.500-10	3.750	5.875	EY 6.5-4-3451■
1	1810	2.500-10	3.750	5.875	EY 6.5-4-3451-1■
1	1810	2.500-10	3.750	5.875	EY 6.5-4-3551-1X■
1	1810	2.500-10	3.750	5.875	EY 6.5-4-3551X■
LPSO140-10S					
1	SPL170	2.500-10	3.750	5.750	EY 170-4-481-1X■
LPSO150-10					
1	1810	2.500-10	3.750	3.625	CF 6.5-1-2271
1	1810	2.500-10	3.750	3.625	CF 6.5-1-2351X
1	SPL250	2.500-10	3.750	6.250	EY 250-4-561-1■
1	1710	2.500-10	3.750	5.625	EY 6-4-6611■
1	1710	2.500-10	3.750	5.625	EY 6-4-6611-1■
1	1710	2.500-10	3.750	5.625	EY 6-4-6921-1X■
1	1710	2.500-10	3.750	5.625	EY 6-4-6921X■
1	1760	2.500-10	3.750	6.000	EY 6.3-4-651■
1	1760	2.500-10	3.750	6.031	EY 6.3-4-651-1■
1	1760	2.500-10	3.750	6.031	EY 6.3-4-781-1X■
1	1760	2.500-10	3.750	6.000	EY 6.3-4-781X■
1	1810	2.500-10	3.750	5.875	EY 6.5-4-3451■
1	1810	2.500-10	3.750	5.875	EY 6.5-4-3451-1■
1	1810	2.500-10	3.750	5.875	EY 6.5-4-3551-1X■
1	1810	2.500-10	3.750	5.875	EY 6.5-4-3551X■
LPSO150-10S					
1	SPL170	2.500-10	3.750	5.750	EY 170-4-481-1X■
LPS025-10					
1	SPL170	2.500-10	3.750	5.750	EY 170-4-471-1■
LPS025-10S					
1	SPL170	2.500-10	3.750	5.750	EY 170-4-481-1X■
LPS140-10, LPS150-10					
1	SPL170	2.500-10	3.750	5.750	EY 170-4-471-1■
PSDO-18A					
1	SPL250	2.794-54	3.750	6.330	EY 250-4-901-1
PSO100-10, PSO115-10					
1	1810	2.500-10	3.750	3.625	CF 6.5-1-2271
1	1810	2.500-10	3.750	3.625	CF 6.5-1-2351X
1	1710	2.500-10	3.750	5.625	EY 6-4-6611■
1	1710	2.500-10	3.750	5.625	EY 6-4-6611-1■
1	1760	2.500-10	3.750	6.000	EY 6.3-4-651■
1	1760	2.500-10	3.750	6.031	EY 6.3-4-651-1■
1	1810	2.500-10	3.750	5.875	EY 6.5-4-3451■
1	1810	2.500-10	3.750	5.875	EY 6.5-4-3451-1■
PSO120-8					
1	SPL170	2.635-20	3.750	6.020	EY 170-4-1111-1X■
		<i>Grnd.hub Dia. 3.000, if used on Spicer 1241 Aux. Trans.</i>			
1	SPL250	2.635-20	3.750	6.270	EY 250-4-511-1■
		<i>Grnd.hub Dia. 3.000, if used on Spicer 1241 Aux. Trans.</i>			
1	SPL250	2.635-20	3.750	6.270	EY 250-4-521-1X■
		<i>Grnd.hub Dia. 3.000, if used on Spicer 1241 Aux. Trans.</i>			

Pos	Series	Spline Data	Hub Dia	* to End of Hub	End Fitting Part Number
PSO120-8 (Continued)					
1	SPL90	2.635-20	3.750	6.020	EY 170-4-1101-1■
		<i>Grnd.hub Dia. 3.000, if used on Spicer 1241 Aux. Trans.</i>			
1	1610	2.635-20	3.750	5.062	EY 5-4-6531-1■
1	1710	2.635-20	3.750	5.188	EY 6-4-5351■
1	1710	2.635-20	3.750	5.188	EY 6-4-5351-1■
1	1710	2.635-20	3.750	5.188	EY 6-4-7071-1X
		<i>Grnd.hub Dia. 3.000, if used on Spicer 1241 Aux. Trans.■</i>			
1	1710	2.635-20	3.750	5.188	EY 6-4-7071X
		<i>Grnd.hub Dia. 3.000, if used on Spicer 1241 Aux. Trans.■</i>			
1	1760	2.635-20	3.750	5.562	EY 6.3-4-41■
		<i>Grnd.hub Dia. 3.000, if used on Spicer 1241 Aux. Trans.</i>			
1	1760	2.635-20	3.750	5.562	EY 6.3-4-41-1■
		<i>Grnd.hub Dia. 3.000, if used on Spicer 1241 Aux. Trans.</i>			
1	1760	2.635-20	3.750	5.562	EY 6.3-4-871-1X■
		<i>Grnd.hub Dia. 3.000, if used on Spicer 1241 Aux. Trans.</i>			
1	1760	2.635-20	3.750	5.562	EY 6.3-4-871-1X■
		<i>Grnd.hub Dia. 3.000, if used on Spicer 1241 Aux. Trans.</i>			
1	1760	2.635-20	3.750	5.562	EY 6.3-4-871X■
		<i>Grnd.hub Dia. 3.000, if used on Spicer 1241 Aux. Trans.</i>			
1	1810	2.635-20	3.750	5.562	EY 6.5-4-3021■
		<i>Grnd.hub Dia. 3.000, if used on Spicer 1241 Aux. Trans.</i>			
1	1810	2.635-20	3.750	5.562	EY 6.5-4-3021-1■
		<i>Grnd.hub Dia. 3.000, if used on Spicer 1241 Aux. Trans.</i>			
1	1810	2.635-20	3.750	5.562	EY 6.5-4-3541-1X■
		<i>Grnd.hub Dia. 3.000, if used on Spicer 1241 Aux. Trans.</i>			
1	1810	2.635-20	3.750	5.562	EY 6.5-4-3541X■
		<i>Grnd.hub Dia. 3.000, if used on Spicer 1241 Aux. Trans.</i>			
PSO120-8LL					
1	SPL250	2.635-20	3.750	6.270	EY 250-4-511-1■
		<i>Grnd.hub Dia. 3.000, if used on Spicer 1241 Aux. Trans.</i>			
1	SPL250	2.635-20	3.750	6.270	EY 250-4-521-1X■
		<i>Grnd.hub Dia. 3.000, if used on Spicer 1241 Aux. Trans.</i>			
1	SPL90	2.635-20	3.750	6.020	EY 170-4-1101-1■
		<i>Grnd.hub Dia. 3.000, if used on Spicer 1241 Aux. Trans.</i>			
1	1610	2.635-20	3.750	5.062	EY 5-4-6531-1■
1	1710	2.635-20	3.750	5.188	EY 6-4-5351■
1	1710	2.635-20	3.750	5.188	EY 6-4-5351-1■
1	1710	2.635-20	3.750	5.188	EY 6-4-7071-1X
		<i>Grnd.hub Dia. 3.000, if used on Spicer 1241 Aux. Trans.■</i>			
1	1710	2.635-20	3.750	5.188	EY 6-4-7071X
		<i>Grnd.hub Dia. 3.000, if used on Spicer 1241 Aux. Trans.■</i>			
1	1760	2.635-20	3.750	5.562	EY 6.3-4-41■
		<i>Grnd.hub Dia. 3.000, if used on Spicer 1241 Aux. Trans.</i>			
1	1760	2.635-20	3.750	5.562	EY 6.3-4-41-1■
		<i>Grnd.hub Dia. 3.000, if used on Spicer 1241 Aux. Trans.</i>			
1	1760	2.635-20	3.750	5.562	EY 6.3-4-871-1X■
		<i>Grnd.hub Dia. 3.000, if used on Spicer 1241 Aux. Trans.</i>			
1	1760	2.635-20	3.750	5.562	EY 6.3-4-871X■
		<i>Grnd.hub Dia. 3.000, if used on Spicer 1241 Aux. Trans.</i>			
1	1810	2.635-20	3.750	5.562	EY 6.5-4-3021■
		<i>Grnd.hub Dia. 3.000, if used on Spicer 1241 Aux. Trans.</i>			
1	1810	2.635-20	3.750	5.562	EY 6.5-4-3021-1■
		<i>Grnd.hub Dia. 3.000, if used on Spicer 1241 Aux. Trans.</i>			
1	1810	2.635-20	3.750	5.562	EY 6.5-4-3541-1X■
		<i>Grnd.hub Dia. 3.000, if used on Spicer 1241 Aux. Trans.</i>			
1	1810	2.635-20	3.750	5.562	EY 6.5-4-3541X■
		<i>Grnd.hub Dia. 3.000, if used on Spicer 1241 Aux. Trans.</i>			
PSO125-10					
1	1810	2.500-10	3.750	3.625	CF 6.5-1-2271
1	1810	2.500-10	3.750	3.625	CF 6.5-1-2351X
1	1710	2.500-10	3.750	5.625	EY 6-4-6611■
1	1710	2.500-10	3.750	5.625	EY 6-4-6611-1■
1	1760	2.500-10	3.750	6.000	EY 6.3-4-651■
1	1760	2.500-10	3.750	6.031	EY 6.3-4-651-1■
1	1810	2.500-10	3.750	5.875	EY 6.5-4-3451■
1	1810	2.500-10	3.750	5.875	EY 6.5-4-3451-1■

*C/L to End of Hub for EY (End Yoke); Flange Face to End of Hub for CF (Companion Flange)

■ Hub machined for speedometer gear



Important: See Safety Information in General Information Section (J300P-GI)

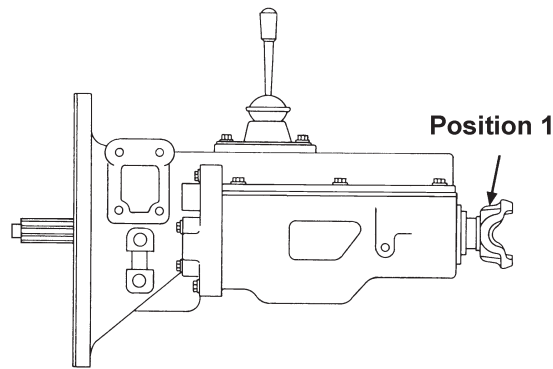

Pos	Series	Spline Data	Hub Dia	* to End of Hub	End Fitting Part Number
-----	--------	-------------	---------	-----------------	-------------------------

PSO130-5, PSO130-6

1	SPL170	2.635-20	3.750	6.020	EY 170-4-1101-1■ <i>Grnd.hub Dia. 3.000, if used on Spicer 1241 Aux. Trans.</i>
1	SPL170	2.635-20	3.750	6.020	EY 170-4-1111-1X■ <i>Grnd.hub Dia. 3.000, if used on Spicer 1241 Aux. Trans.</i>
1	SPL250	2.635-20	3.750	6.270	EY 250-4-511-1■ <i>Grnd.hub Dia. 3.000, if used on Spicer 1241 Aux. Trans.</i>
1	SPL250	2.635-20	3.750	6.270	EY 250-4-521-1X■ <i>Grnd.hub Dia. 3.000, if used on Spicer 1241 Aux. Trans.</i>
1	1610	2.635-20	3.750	5.062	EY 5-4-6531-1■
1	1710	2.635-20	3.750	5.188	EY 6-4-5351■
1	1710	2.635-20	3.750	5.188	EY 6-4-5351-1■
1	1710	2.635-20	3.750	5.188	EY 6-4-7071-1X
					<i>Grnd.hub Dia. 3.000, if used on Spicer 1241 Aux. Trans.■</i>
1	1710	2.635-20	3.750	5.188	EY 6-4-7071X
					<i>Grnd.hub Dia. 3.000, if used on Spicer 1241 Aux. Trans.■</i>
1	1760	2.635-20	3.750	5.562	EY 6.3-4-41■ <i>Grnd.hub Dia. 3.000, if used on Spicer 1241 Aux. Trans.</i>
1	1760	2.635-20	3.750	5.562	EY 6.3-4-41-1■ <i>Grnd.hub Dia. 3.000, if used on Spicer 1241 Aux. Trans.</i>
1	1760	2.635-20	3.750	5.562	EY 6.3-4-871-1X■ <i>Grnd.hub Dia. 3.000, if used on Spicer 1241 Aux. Trans.</i>
1	1760	2.635-20	3.750	5.562	EY 6.3-4-871X■ <i>Grnd.hub Dia. 3.000, if used on Spicer 1241 Aux. Trans.</i>
1	1810	2.635-20	3.750	5.562	EY 6.5-4-3021■ <i>Grnd.hub Dia. 3.000, if used on Spicer 1241 Aux. Trans.</i>
1	1810	2.635-20	3.750	5.562	EY 6.5-4-3021-1■ <i>Grnd.hub Dia. 3.000, if used on Spicer 1241 Aux. Trans.</i>
1	1810	2.635-20	3.750	5.562	EY 6.5-4-3541-1X■ <i>Grnd.hub Dia. 3.000, if used on Spicer 1241 Aux. Trans.</i>
1	1810	2.635-20	3.750	5.562	EY 6.5-4-3541X■ <i>Grnd.hub Dia. 3.000, if used on Spicer 1241 Aux. Trans.</i>

PSO140-10

1	1810	2.500-10	3.750	3.625	CF 6.5-1-2271
1	1810	2.500-10	3.750	3.625	CF 6.5-1-2351X
1	1710	2.500-10	3.750	5.625	EY 6-4-6611-1■
1	1760	2.500-10	3.750	6.000	EY 6.3-4-651■
1	1760	2.500-10	3.750	6.031	EY 6.3-4-651-1■
1	1810	2.500-10	3.750	5.875	EY 6.5-4-3451■
1	1810	2.500-10	3.750	5.875	EY 6.5-4-3451-1■

PSO140-6

1	SPL170	2.635-20	3.750	6.020	EY 170-4-1101-1■ <i>Grnd.hub Dia. 3.000, if used on Spicer 1241 Aux. Trans.</i>
1	SPL170	2.635-20	3.750	6.020	EY 170-4-1111-1X■ <i>Grnd.hub Dia. 3.000, if used on Spicer 1241 Aux. Trans.</i>
1	SPL250	2.635-20	3.750	6.270	EY 250-4-511-1■ <i>Grnd.hub Dia. 3.000, if used on Spicer 1241 Aux. Trans.</i>

Pos	Series	Spline Data	Hub Dia	* to End of Hub	End Fitting Part Number
-----	--------	-------------	---------	-----------------	-------------------------

PSO140-6 (Continued)

1	SPL250	2.635-20	3.750	6.270	EY 250-4-521-1X■ <i>Grnd.hub Dia. 3.000, if used on Spicer 1241 Aux. Trans.</i>
1	1610	2.635-20	3.750	5.062	EY 5-4-6531-1■
1	1710	2.635-20	3.750	5.188	EY 6-4-5351■
1	1710	2.635-20	3.750	5.188	EY 6-4-5351-1■
1	1710	2.635-20	3.750	5.188	EY 6-4-7071-1X
					<i>Grnd.hub Dia. 3.000, if used on Spicer 1241 Aux. Trans.■</i>
1	1710	2.635-20	3.750	5.188	EY 6-4-7071X
					<i>Grnd.hub Dia. 3.000, if used on Spicer 1241 Aux. Trans.■</i>
1	1760	2.635-20	3.750	5.562	EY 6.3-4-41■ <i>Grnd.hub Dia. 3.000, if used on Spicer 1241 Aux. Trans.</i>
1	1760	2.635-20	3.750	5.562	EY 6.3-4-41-1■ <i>Grnd.hub Dia. 3.000, if used on Spicer 1241 Aux. Trans.</i>
1	1760	2.635-20	3.750	5.562	EY 6.3-4-871-1X■ <i>Grnd.hub Dia. 3.000, if used on Spicer 1241 Aux. Trans.</i>
1	1760	2.635-20	3.750	5.562	EY 6.3-4-871X■ <i>Grnd.hub Dia. 3.000, if used on Spicer 1241 Aux. Trans.</i>
1	1810	2.635-20	3.750	5.562	EY 6.5-4-3021■ <i>Grnd.hub Dia. 3.000, if used on Spicer 1241 Aux. Trans.</i>
1	1810	2.635-20	3.750	5.562	EY 6.5-4-3021-1■ <i>Grnd.hub Dia. 3.000, if used on Spicer 1241 Aux. Trans.</i>
1	1810	2.635-20	3.750	5.562	EY 6.5-4-3541-1X■ <i>Grnd.hub Dia. 3.000, if used on Spicer 1241 Aux. Trans.</i>
1	1810	2.635-20	3.750	5.562	EY 6.5-4-3541X■ <i>Grnd.hub Dia. 3.000, if used on Spicer 1241 Aux. Trans.</i>

PSO140-9

1	1810	2.500-10	3.750	3.625	CF 6.5-1-2271
1	1810	2.500-10	3.750	3.625	CF 6.5-1-2351X
1	1710	2.500-10	3.750	5.625	EY 6-4-6921-1X■
1	1710	2.500-10	3.750	5.625	EY 6-4-6921X■
1	1760	2.500-10	3.750	6.031	EY 6.3-4-781-1X■
1	1760	2.500-10	3.750	6.000	EY 6.3-4-781X■
1	1810	2.500-10	3.750	5.875	EY 6.5-4-3551-1X■
1	1810	2.500-10	3.750	5.875	EY 6.5-4-3551X■

PSO140-12

1	SPL170	2.635-20	3.750	6.020	EY 170-4-1101-1■ <i>Grnd.hub Dia. 3.000, if used on Spicer 1241 Aux. Trans.</i>
1	SPL170	2.635-20	3.750	6.020	EY 170-4-1111-1X■ <i>Grnd.hub Dia. 3.000, if used on Spicer 1241 Aux. Trans.</i>
1	SPL250	2.635-20	3.750	6.270	EY 250-4-511-1■ <i>Grnd.hub Dia. 3.000, if used on Spicer 1241 Aux. Trans.</i>
1	SPL250	2.635-20	3.750	6.270	EY 250-4-521-1X■ <i>Grnd.hub Dia. 3.000, if used on Spicer 1241 Aux. Trans.</i>
1	1610	2.635-20	3.750	5.062	EY 5-4-6531-1■
1	1710	2.635-20	3.750	5.188	EY 6-4-5351■
1	1710	2.635-20	3.750	5.188	EY 6-4-5351-1■

*C/L to End of Hub for EY (End Yoke); Flange Face to End of Hub for CF (Companion Flange)

■ Hub machined for speedometer gear



Pos	Series	Spline Data	Hub Dia	* to End of Hub	End Fitting Part Number
PSO140-12 (Continued)					
1	1710	2.635-20	3.750	5.188	EY 6-4-7071-1X <i>Gmd.hub Dia. 3.000, if used on Spicer 1241 Aux. Trans. ■</i>
1	1710	2.635-20	3.750	5.188	EY 6-4-7071X <i>Gmd.hub Dia. 3.000, if used on Spicer 1241 Aux. Trans. ■</i>
1	1760	2.635-20	3.750	5.562	EY 6.3-4-41■ <i>Gmd.hub Dia. 3.000, if used on Spicer 1241 Aux. Trans.</i>
1	1760	2.635-20	3.750	5.562	EY 6.3-4-41-1■ <i>Gmd.hub Dia. 3.000, if used on Spicer 1241 Aux. Trans.</i>
1	1760	2.635-20	3.750	5.562	EY 6.3-4-871-1X■ <i>Gmd.hub Dia. 3.000, if used on Spicer 1241 Aux. Trans.</i>
1	1760	2.635-20	3.750	5.562	EY 6.3-4-871X■ <i>Gmd.hub Dia. 3.000, if used on Spicer 1241 Aux. Trans.</i>
1	1810	2.635-20	3.750	5.562	EY 6.5-4-3021■ <i>Gmd.hub Dia. 3.000, if used on Spicer 1241 Aux. Trans.</i>
1	1810	2.635-20	3.750	5.562	EY 6.5-4-3021-1■ <i>Gmd.hub Dia. 3.000, if used on Spicer 1241 Aux. Trans.</i>
1	1810	2.635-20	3.750	5.562	EY 6.5-4-3541-1X■ <i>Gmd.hub Dia. 3.000, if used on Spicer 1241 Aux. Trans.</i>
1	1810	2.635-20	3.750	5.562	EY 6.5-4-3541X■ <i>Gmd.hub Dia. 3.000, if used on Spicer 1241 Aux. Trans.</i>

PSO150-10					
1	1810	2.500-10	3.750	3.625	CF 6.5-1-2271
1	1810	2.500-10	3.750	3.625	CF 6.5-1-2351X
1	1710	2.500-10	3.750	5.625	EY 6-4-6611■
1	1710	2.500-10	3.750	5.625	EY 6-4-6611-1■
1	1760	2.500-10	3.750	6.000	EY 6.3-4-651■
1	1760	2.500-10	3.750	6.031	EY 6.3-4-651-1■
1	1810	2.500-10	3.750	5.875	EY 6.5-4-3451■
1	1810	2.500-10	3.750	5.875	EY 6.5-4-3451-1■

PSO150-16					
1	SPL170	2.635-20	3.750	6.020	EY 170-4-1101-1■ <i>Gmd.hub Dia. 3.000, if used on Spicer 1241 Aux. Trans.</i>
1	SPL170	2.635-20	3.750	6.020	EY 170-4-1111-1X■ <i>Gmd.hub Dia. 3.000, if used on Spicer 1241 Aux. Trans.</i>
1	SPL250	2.635-20	3.750	6.270	EY 250-4-511-1■ <i>Gmd.hub Dia. 3.000, if used on Spicer 1241 Aux. Trans.</i>
1	SPL250	2.635-20	3.750	6.270	EY 250-4-521-1X■ <i>Gmd.hub Dia. 3.000, if used on Spicer 1241 Aux. Trans.</i>
1	1610	2.635-20	3.750	5.062	EY 5-4-6531-1■
1	1710	2.635-20	3.750	5.188	EY 6-4-5351■
1	1710	2.635-20	3.750	5.188	EY 6-4-5351-1■
1	1710	2.635-20	3.750	5.188	EY 6-4-7071-1X
<i>Gmd.hub Dia. 3.000, if used on Spicer 1241 Aux. Trans. ■</i>					
1	1760	2.635-20	3.750	5.562	EY 6.3-4-41■ <i>Gmd.hub Dia. 3.000, if used on Spicer 1241 Aux. Trans.</i>
1	1760	2.635-20	3.750	5.562	EY 6.3-4-41-1■ <i>Gmd.hub Dia. 3.000, if used on Spicer 1241 Aux. Trans.</i>
1	1760	2.635-20	3.750	5.562	EY 6.3-4-871-1X■ <i>Gmd.hub Dia. 3.000, if used on Spicer 1241 Aux. Trans.</i>
1	1760	2.635-20	3.750	5.562	EY 6.3-4-871X■ <i>Gmd.hub Dia. 3.000, if used on Spicer 1241 Aux. Trans.</i>
1	1810	2.635-20	3.750	5.562	EY 6.5-4-3021■ <i>Gmd.hub Dia. 3.000, if used on Spicer 1241 Aux. Trans.</i>
1	1810	2.635-20	3.750	5.562	EY 6.5-4-3021-1■ <i>Gmd.hub Dia. 3.000, if used on Spicer 1241 Aux. Trans.</i>
1	1810	2.635-20	3.750	5.562	EY 6.5-4-3541-1X■ <i>Gmd.hub Dia. 3.000, if used on Spicer 1241 Aux. Trans.</i>
1	1810	2.635-20	3.750	5.562	EY 6.5-4-3541X■ <i>Gmd.hub Dia. 3.000, if used on Spicer 1241 Aux. Trans.</i>

Pos	Series	Spline Data	Hub Dia	* to End of Hub	End Fitting Part Number
PSO170-18					
1	SPL170	2.635-20	3.750	6.020	EY 170-4-1111-1X■ <i>Gmd.hub Dia. 3.000, if used on Spicer 1241 Aux. Trans.</i>
1	SPL250	2.635-20	3.750	6.270	EY 250-4-521-1X■ <i>Gmd.hub Dia. 3.000, if used on Spicer 1241 Aux. Trans.</i>
1	1710	2.635-20	3.750	5.188	EY 6-4-7071-1X <i>Gmd.hub Dia. 3.000, if used on Spicer 1241 Aux. Trans. ■</i>
1	1710	2.635-20	3.750	5.188	EY 6-4-7071X <i>Gmd.hub Dia. 3.000, if used on Spicer 1241 Aux. Trans. ■</i>
1	1760	2.635-20	3.750	5.562	EY 6.3-4-871-1X■ <i>Gmd.hub Dia. 3.000, if used on Spicer 1241 Aux. Trans.</i>
1	1760	2.635-20	3.750	5.562	EY 6.3-4-871X■ <i>Gmd.hub Dia. 3.000, if used on Spicer 1241 Aux. Trans.</i>
1	1810	2.635-20	3.750	5.562	EY 6.5-4-3541-1X■ <i>Gmd.hub Dia. 3.000, if used on Spicer 1241 Aux. Trans.</i>
1	1810	2.635-20	3.750	5.562	EY 6.5-4-3541X■ <i>Gmd.hub Dia. 3.000, if used on Spicer 1241 Aux. Trans.</i>

PSO175-18					
1	1810	2.422-18	3.375	5.812	CF 6.5-4-1991
1	SPL250	2.635-20	3.750	6.270	EY 250-4-511-1■ <i>Gmd.hub Dia. 3.000, if used on Spicer 1241 Aux. Trans.</i>
1	SPL90	2.635-20	3.750	6.020	EY 170-4-1101-1■ <i>Gmd.hub Dia. 3.000, if used on Spicer 1241 Aux. Trans.</i>
1	1610	2.635-20	3.750	5.062	EY 5-4-6531-1■
1	1710	2.635-20	3.750	5.188	EY 6-4-5351■
1	1710	2.635-20	3.750	5.188	EY 6-4-5351-1■
1	1760	2.635-20	3.750	5.562	EY 6.3-4-41■ <i>Gmd.hub Dia. 3.000, if used on Spicer 1241 Aux. Trans.</i>
1	1760	2.635-20	3.750	5.562	EY 6.3-4-41-1■ <i>Gmd.hub Dia. 3.000, if used on Spicer 1241 Aux. Trans.</i>
1	1810	2.635-20	3.750	5.562	EY 6.5-4-3021■ <i>Gmd.hub Dia. 3.000, if used on Spicer 1241 Aux. Trans.</i>
1	1810	2.635-20	3.750	5.562	EY 6.5-4-3021-1■ <i>Gmd.hub Dia. 3.000, if used on Spicer 1241 Aux. Trans.</i>

PS86-10					
1	1810	2.500-10	3.750	3.625	CF 6.5-1-2271
1	1810	2.500-10	3.750	3.625	CF 6.5-1-2351X
1	1710	2.500-10	3.750	5.625	EY 6-4-6611■
1	1710	2.500-10	3.750	5.625	EY 6-4-6611-1■
1	1760	2.500-10	3.750	6.000	EY 6.3-4-651■
1	1760	2.500-10	3.750	6.031	EY 6.3-4-651-1■
1	1810	2.500-10	3.750	5.875	EY 6.5-4-3451■
1	1810	2.500-10	3.750	5.875	EY 6.5-4-3451-1■

PS97-7					
1	SPL140	2.544-49	4.000	6.060	EY 140-4-881-1
1	SPL170	2.544-49	4.000	6.050	EY 170-4-1161-1
1	SPL90	2.250-10	3.500	5.219	EY 90-4-151-1X
1	1610	2.547-49	4.000	5.500	EY 5-4-7951-1
1	1710	2.544-49	4.000	5.188	EY 6-4-7691■
1	1710	2.544-49	4.000	5.188	EY 6-4-7691-1■
1	1760	2.544-49	4.000	5.562	EY 6.3-4-1251
1	1760	2.544-49	4.000	5.562	EY 6.3-4-1251-1
1	1810	2.544-49	4.000	5.562	EY 6.5-4-3821-1

PS97-7A					
1	1760	2.544-49	4.000	5.562	EY 6.3-4-1251
1	1760	2.544-49	4.000	5.562	EY 6.3-4-1251-1

*C/L to End of Hub for EY (End Yoke); Flange Face to End of Hub for CF (Companion Flange)

■ Hub machined for speedometer gear



Important: See Safety Information in General Information Section (J300P-GI)

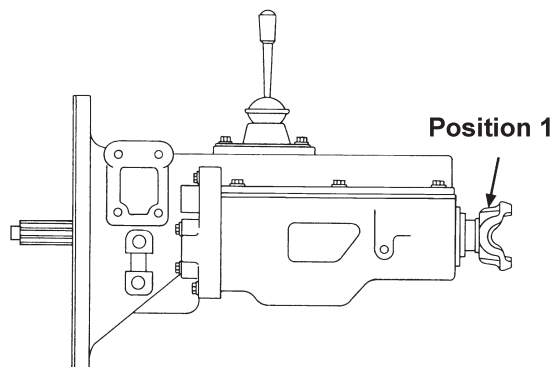

Pos	Series	Spline Data	Hub Dia	* to End of Hub	End Fitting Part Number
PS100-10					
1	1810	2.500-10	3.750	3.625	CF 6.5-1-2271
1	1810	2.500-10	3.750	3.625	CF 6.5-1-2351X
1	1710	2.500-10	3.750	5.625	EY 6-4-6611■
1	1710	2.500-10	3.750	5.625	EY 6-4-6611-1■
1	1760	2.500-10	3.750	6.000	EY 6.3-4-651■
1	1760	2.500-10	3.750	6.031	EY 6.3-4-651-1■
1	1810	2.500-10	3.750	5.875	EY 6.5-4-3451■
1	1810	2.500-10	3.750	5.875	EY 6.5-4-3451-1■
PS105-7					
1	SPL90	2.250-10	3.500	5.219	EY 90-4-151-1X
1	1610	2.547-49	4.000	5.500	EY 5-4-7951-1
1	1710	2.544-49	4.000	5.188	EY 6-4-7691■
1	1710	2.544-49	4.000	5.188	EY 6-4-7691-1■
1	1760	2.544-49	4.000	5.562	EY 6.3-4-1251
1	1760	2.544-49	4.000	5.562	EY 6.3-4-1251-1
1	1810	2.544-49	4.000	5.562	EY 6.5-4-3821-1
PS110-7					
1	SPL140	2.544-49	4.000	6.060	EY 140-4-881-1
1	SPL170	2.544-49	4.000	6.050	EY 170-4-1161-1
1	1610	2.547-49	4.000	5.500	EY 5-4-7951-1
1	1710	2.544-49	4.000	5.188	EY 6-4-7691■
1	1710	2.544-49	4.000	5.188	EY 6-4-7691-1■
1	1760	2.544-49	4.000	5.562	EY 6.3-4-1251
1	1760	2.544-49	4.000	5.562	EY 6.3-4-1251-1
1	1810	2.544-49	4.000	5.562	EY 6.5-4-3821-1
PS125-10					
1	1710	2.500-10	3.750	3.625	CF 6-1-5541
1	1810	2.500-10	3.750	3.625	CF 6.5-1-2271
1	1810	2.500-10	3.750	3.625	CF 6.5-1-2351X
1	SPL170	2.500-10	3.750	5.750	EY 170-4-471-1■
1	SPL250	2.500-10	3.750	6.250	EY 250-4-561-1■
1	1710	2.500-10	3.750	5.625	EY 6-4-6611■
1	1710	2.500-10	3.750	5.625	EY 6-4-6611-1■
1	1710	2.500-10	3.750	5.625	EY 6-4-6921-1X■
1	1710	2.500-10	3.750	5.625	EY 6-4-6921X■
1	1760	2.500-10	3.750	6.000	EY 6.3-4-651■
1	1760	2.500-10	3.750	6.031	EY 6.3-4-651-1■
1	1760	2.500-10	3.750	6.031	EY 6.3-4-781-1X■
1	1760	2.500-10	3.750	6.000	EY 6.3-4-781X■
1	1810	2.500-10	3.750	5.875	EY 6.5-4-3451■
1	1810	2.500-10	3.750	5.875	EY 6.5-4-3451-1■
1	1810	2.500-10	3.750	5.875	EY 6.5-4-3551-1X■
1	1810	2.500-10	3.750	5.875	EY 6.5-4-3551X■

Pos	Series	Spline Data	Hub Dia	* to End of Hub	End Fitting Part Number
PS125-10A					
1	SPL170	2.500-10	3.750	5.750	EY 170-4-481-1X■
PS125-7					
1	SPL140	2.544-49	4.000	6.060	EY 140-4-881-1
1	SPL170	2.544-49	4.000	6.050	EY 170-4-1161-1
1	SPL90	2.250-10	3.500	5.219	EY 90-4-151-1X
1	1610	2.547-49	4.000	5.500	EY 5-4-7951-1
1	1710	2.544-49	4.000	5.188	EY 6-4-7691-1■
1	1760	2.544-49	4.000	5.562	EY 6.3-4-1251
1	1760	2.544-49	4.000	5.562	EY 6.3-4-1251-1
1	1810	2.544-49	4.000	5.562	EY 6.5-4-3821-1
PS125-7B					
1	1760	2.544-49	4.000	5.562	EY 6.3-4-1251
1	1760	2.544-49	4.000	5.562	EY 6.3-4-1251-1
PS125-9					
1	1710	2.500-10	3.750	3.625	CF 6-1-5541
1	1810	2.500-10	3.750	3.625	CF 6.5-1-2271
1	1810	2.500-10	3.750	3.625	CF 6.5-1-2351X
1	SPL170	2.500-10	3.750	5.750	EY 170-4-471-1■
1	SPL250	2.500-10	3.750	6.250	EY 250-4-561-1■
1	1710	2.500-10	3.750	5.625	EY 6-4-6611■
1	1710	2.500-10	3.750	5.625	EY 6-4-6611-1■
1	1710	2.500-10	3.750	5.625	EY 6-4-6921-1X■
1	1710	2.500-10	3.750	5.625	EY 6-4-6921X■
1	1760	2.500-10	3.750	6.000	EY 6.3-4-651■
1	1760	2.500-10	3.750	6.031	EY 6.3-4-651-1■
1	1760	2.500-10	3.750	6.031	EY 6.3-4-781-1X■
1	1760	2.500-10	3.750	6.000	EY 6.3-4-781X■
1	1810	2.500-10	3.750	5.875	EY 6.5-4-3451■
1	1810	2.500-10	3.750	5.875	EY 6.5-4-3451-1■
1	1810	2.500-10	3.750	5.875	EY 6.5-4-3551-1X■
1	1810	2.500-10	3.750	5.875	EY 6.5-4-3551X■
PS125-9A					
1	SPL170	2.500-10	3.750	5.750	EY 170-4-481-1X■
PS130-5, PS130-6					
1	1610	2.635-20	3.750	5.062	EY 5-4-6531-1■
1	1710	2.635-20	3.750	5.188	EY 6-4-5351■
1	1710	2.635-20	3.750	5.188	EY 6-4-5351-1■
1	1710	2.635-20	3.750	5.188	EY 6-4-7071-1X
1	1710	2.635-20	3.750	5.188	EY 6-4-7071X
1	1760	2.635-20	3.750	5.562	EY 6.3-4-41■

*C/L to End of Hub for EY (End Yoke); Flange Face to End of Hub for CF (Companion Flange)

■ Hub machined for speedometer gear



Pos	Series	Spline Data	Hub Dia	* to End of Hub	End Fitting Part Number
PS130-5, PS130-6 (Continued)					
1	1760	2.635-20	3.750	5.562	EY 6.3-4-41-1■ <i>Grnd.hub Dia. 3.000, if used on Spicer 1241 Aux. Trans.</i>
1	1760	2.635-20	3.750	5.562	EY 6.3-4-871-1X■ <i>Grnd.hub Dia. 3.000, if used on Spicer 1241 Aux. Trans.</i>
1	1760	2.635-20	3.750	5.562	EY 6.3-4-871X■ <i>Grnd.hub Dia. 3.000, if used on Spicer 1241 Aux. Trans.</i>
1	1810	2.635-20	3.750	5.562	EY 6.5-4-3541-1X■ <i>Grnd.hub Dia. 3.000, if used on Spicer 1241 Aux. Trans.</i>
1	1810	2.635-20	3.750	5.562	EY 6.5-4-3541X <i>Hub machined for speedometer gear Grnd.hub Dia. 3.000, if used on Spicer 1241 Aux. Trans.</i>

Pos	Series	Spline Data	Hub Dia	* to End of Hub	End Fitting Part Number
PS140-7					
1	SPL140	2.544-49	4.000	6.060	EY 140-4-881-1
1	SPL170	2.544-49	4.000	6.050	EY 170-4-1161-1
1	1610	2.547-49	4.000	5.500	EY 5-4-7951-1
1	1710	2.544-49	4.000	5.188	EY 6-4-7691■
1	1710	2.544-49	4.000	5.188	EY 6-4-7691-1■
1	1760	2.544-49	4.000	5.562	EY 6.3-4-1251
1	1760	2.544-49	4.000	5.562	EY 6.3-4-1251-1
1	1810	2.544-49	4.000	5.562	EY 6.5-4-3821-1

Pos	Series	Spline Data	Hub Dia	* to End of Hub	End Fitting Part Number
PS140-7A					
1	1760	2.544-49	4.000	5.562	EY 6.3-4-1251
1	1760	2.544-49	4.000	5.562	EY 6.3-4-1251-1

Pos	Series	Spline Data	Hub Dia	* to End of Hub	End Fitting Part Number
PS140-9					
1	1810	2.500-10	3.750	3.625	CF 6.5-1-2271
1	1810	2.500-10	3.750	3.625	CF 6.5-1-2351X
1	SPL170	2.500-10	3.750	5.750	EY 170-4-471-1■
1	SPL250	2.500-10	3.750	6.250	EY 250-4-561-1■
1	1710	2.500-10	3.750	5.625	EY 6-4-6611■
1	1710	2.500-10	3.750	5.625	EY 6-4-6611-1■
1	1710	2.500-10	3.750	5.625	EY 6-4-6921-1X■
1	1710	2.500-10	3.750	5.625	EY 6-4-6921X■
1	1760	2.500-10	3.750	6.000	EY 6.3-4-651■
1	1760	2.500-10	3.750	6.031	EY 6.3-4-651-1■
1	1760	2.500-10	3.750	6.031	EY 6.3-4-781-1X■
1	1760	2.500-10	3.750	6.000	EY 6.3-4-781X■
1	1810	2.500-10	3.750	5.875	EY 6.5-4-3451■
1	1810	2.500-10	3.750	5.875	EY 6.5-4-3451-1■
1	1810	2.500-10	3.750	5.875	EY 6.5-4-3551-1X■
1	1810	2.500-10	3.750	5.875	EY 6.5-4-3551X■

Pos	Series	Spline Data	Hub Dia	* to End of Hub	End Fitting Part Number
PS140-9A					
1	SPL170	2.500-10	3.750	5.750	EY 170-4-481-1X■

Pos	Series	Spline Data	Hub Dia	* to End of Hub	End Fitting Part Number
PS140-10					
1	1810	2.500-10	3.750	3.625	CF 6.5-1-2271
1	1810	2.500-10	3.750	3.625	CF 6.5-1-2351X
1	SPL170	2.500-10	3.750	5.750	EY 170-4-471-1■
1	SPL250	2.500-10	3.750	6.250	EY 250-4-561-1■
1	1710	2.500-10	3.750	5.625	EY 6-4-6611■
1	1710	2.500-10	3.750	5.625	EY 6-4-6611-1■
1	1710	2.500-10	3.750	5.625	EY 6-4-6921-1X■
1	1710	2.500-10	3.750	5.625	EY 6-4-6921X■
1	1760	2.500-10	3.750	6.000	EY 6.3-4-651■
1	1760	2.500-10	3.750	6.031	EY 6.3-4-781-1X■
1	1760	2.500-10	3.750	6.000	EY 6.3-4-781X■
1	1810	2.500-10	3.750	5.875	EY 6.5-4-3451■
1	1810	2.500-10	3.750	5.875	EY 6.5-4-3551-1X■
1	1810	2.500-10	3.750	5.875	EY 6.5-4-3551X■

Pos	Series	Spline Data	Hub Dia	* to End of Hub	End Fitting Part Number
PS145-7					
1	SPL140	2.544-49	4.000	6.060	EY 140-4-881-1
1	SPL170	2.544-49	4.000	6.050	EY 170-4-1161-1
1	1610	2.547-49	4.000	5.500	EY 5-4-7951-1
1	1710	2.544-49	4.000	5.188	EY 6-4-7691■
1	1710	2.544-49	4.000	5.188	EY 6-4-7691-1■
1	1760	2.544-49	4.000	5.562	EY 6.3-4-1251
1	1760	2.544-49	4.000	5.562	EY 6.3-4-1251-1
1	1810	2.544-49	4.000	5.562	EY 6.5-4-3821-1

Pos	Series	Spline Data	Hub Dia	* to End of Hub	End Fitting Part Number
P8516, P8716, R8516, R8716					
1	1610	2.225-6	3.000	3.875	CF 5-1-2541
1	1650/1710	2.225-6	3.000	4.469	CF 6-1-1481
1	1650/1710	2.225-6	3.000	3.750	CF 6-1-1731
1	1810	2.225-6	3.000	3.750	CF 6.5-1-481
1	1710	2.225-6	3.000	5.438	EY 6-4-3041-1X
1	1710	2.225-6	3.000	5.312	EY 6-4-3041X

Pos	Series	Spline Data	Hub Dia	* to End of Hub	End Fitting Part Number
S110					
1	SPL55	2.024-39	3.000	3.875	EY 5003328

Pos	Series	Spline Data	Hub Dia	* to End of Hub	End Fitting Part Number
1006, 1006-A					
1	1610	2.635-20	3.750	5.062	EY 5-4-6531-1■
1	1710	2.635-20	3.750	5.188	EY 6-4-7071-1X
1	1710	2.635-20	3.750	5.188	EY 6-4-7071X
1	1760	2.635-20	3.750	5.562	EY 6.3-4-41■ <i>Grnd.hub Dia. 3.000, if used on Spicer 1241 Aux. Trans.</i>
1	1760	2.635-20	3.750	5.562	EY 6.3-4-41-1■ <i>Grnd.hub Dia. 3.000, if used on Spicer 1241 Aux. Trans.</i>
1	1760	2.635-20	3.750	5.562	EY 6.3-4-871-1X■ <i>Grnd.hub Dia. 3.000, if used on Spicer 1241 Aux. Trans.</i>
1	1760	2.635-20	3.750	5.562	EY 6.3-4-871X■ <i>Hub machined for speedometer gear Grnd.hub Dia. 3.000, if used on Spicer 1241 Aux. Trans.</i>
1	1810	2.635-20	3.750	5.562	EY 6.5-4-2011■
1	1810	2.635-20	3.750	5.562	EY 6.5-4-3021■ <i>Grnd.hub Dia. 3.000, if used on Spicer 1241 Aux. Trans.</i>
1	1810	2.635-20	3.750	5.562	EY 6.5-4-3021-1■ <i>Grnd.hub Dia. 3.000, if used on Spicer 1241 Aux. Trans.</i>
1	1810	2.635-20	3.750	5.562	EY 6.5-4-3541-1X■ <i>Grnd.hub Dia. 3.000, if used on Spicer 1241 Aux. Trans.</i>
1	1810	2.635-20	3.750	5.562	EY 6.5-4-3541X■ <i>Grnd.hub Dia. 3.000, if used on Spicer 1241 Aux. Trans.</i>

Pos	Series	Spline Data	Hub Dia	* to End of Hub	End Fitting Part Number
1007, 1007-2A, 1007-2B, 1007-2C, 1007-2D, 1007-3A					
1	1610	2.635-20	3.750	5.062	EY 5-4-6531-1■
1	1710	2.635-20	3.750	5.188	EY 6-4-5351■
1	1710	2.635-20	3.750	5.188	EY 6-4-7071-1X
1	1710	2.635-20	3.750	5.188	EY 6-4-7071X
1	1760	2.635-20	3.750	5.562	EY 6.3-4-41■ <i>Grnd.hub Dia. 3.000, if used on Spicer 1241 Aux. Trans.</i>
1	1760	2.635-20	3.750	5.562	EY 6.3-4-41-1■ <i>Grnd.hub Dia. 3.000, if used on Spicer 1241 Aux. Trans.</i>
1	1760	2.635-20	3.750	5.562	EY 6.3-4-871-1X■ <i>Grnd.hub Dia. 3.000, if used on Spicer 1241 Aux. Trans.</i>
1	1760	2.635-20	3.750	5.562	EY 6.3-4-871X■ <i>Grnd.hub Dia. 3.000, if used on Spicer 1241 Aux. Trans.</i>
1	1810	2.635-20	3.750	5.562	EY 6.5-4-2011■
1	1810	2.635-20	3.750	5.562	EY 6.5-4-3021■
1	1810	2.635-20	3.750	5.562	EY 6.5-4-3021-1■ <i>Grnd.hub Dia. 3.000, if used on Spicer 1241 Aux. Trans.</i>

Continued on next page

*C/L to End of Hub for EY (End Yoke); Flange Face to End of Hub for CF (Companion Flange)
■ Hub machined for speedometer gear



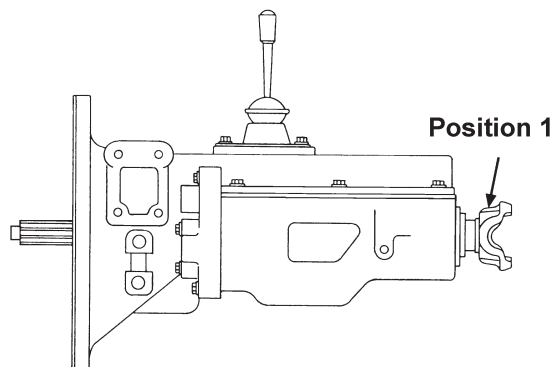

Pos	Series	Spline Data	Hub Dia	* to End of Hub	End Fitting Part Number
-----	--------	-------------	---------	-----------------	-------------------------

1007, 1007-2A, 1007-2B, 1007-2C, 1007-2D, 1007-3A (Continued)

1	1810	2.635-20	3.750	5.562	EY 6.5-4-3021-1■ <i>Grnd.hub Dia. 3.000, if used on Spicer 1241 Aux. Trans.</i>
1	1810	2.635-20	3.750	5.562	EY 6.5-4-3541-1X■ <i>Grnd.hub Dia. 3.000, if used on Spicer 1241 Aux. Trans.</i>
1	1810	2.635-20	3.750	5.562	EY 6.5-4-3541X■ <i>Grnd.hub Dia. 3.000, if used on Spicer 1241 Aux. Trans.</i>

1010-2A, 1010-3A, 1010-3B, 1010-4A, 1010-5A

1	1650/1710	2.351-16	3.750	3.000	CF 6-1-4571 <i>Hub machined for speedometer gear and no.3 woodruff keyway</i>
1	1710	2.351-16	3.750	5.188	EY 6-4-4531■
1	1710	2.350-16	3.750	5.188	EY 6-4-5341■
1	1810	2.350-16	3.750	5.562	EY 6.5-4-3011■

1020, 1020-2A, 1020-3A, 1020-4A, 1020-5A

1	1610	2.635-20	3.750	5.062	EY 5-4-6531-1■
1	1710	2.635-20	3.750	5.188	EY 6-4-7071-1X■ <i>Grnd.hub Dia. 3.000, if used on Spicer 1241 Aux. Trans.■</i>
1	1710	2.635-20	3.750	5.188	EY 6-4-7071X■ <i>Grnd.hub Dia. 3.000, if used on Spicer 1241 Aux. Trans.■</i>
1	1760	2.635-20	3.750	5.562	EY 6.3-4-41■ <i>Grnd.hub Dia. 3.000, if used on Spicer 1241 Aux. Trans.</i>
1	1760	2.635-20	3.750	5.562	EY 6.3-4-41-1■ <i>Grnd.hub Dia. 3.000, if used on Spicer 1241 Aux. Trans.</i>
1	1760	2.635-20	3.750	5.562	EY 6.3-4-871-1X■ <i>Grnd.hub Dia. 3.000, if used on Spicer 1241 Aux. Trans.</i>
1	1760	2.635-20	3.750	5.562	EY 6.3-4-871X■ <i>Grnd.hub Dia. 3.000, if used on Spicer 1241 Aux. Trans.</i>
1	1810	2.635-20	3.750	5.562	EY 6.5-4-2011■
1	1810	2.635-20	3.750	5.562	EY 6.5-4-3021■ <i>Grnd.hub Dia. 3.000, if used on Spicer 1241 Aux. Trans.</i>
1	1810	2.635-20	3.750	5.562	EY 6.5-4-3021-1■ <i>Grnd.hub Dia. 3.000, if used on Spicer 1241 Aux. Trans.</i>
1	1810	2.635-20	3.750	5.562	EY 6.5-4-3541-1X■ <i>Grnd.hub Dia. 3.000, if used on Spicer 1241 Aux. Trans.</i>
1	1810	2.635-20	3.750	5.562	EY 6.5-4-3541X■ <i>Grnd.hub Dia. 3.000, if used on Spicer 1241 Aux. Trans.</i>

1052, 1052A, 1054, 1054A, 1062, 1062A, 1062B, 1064, 1064A, 1064B

1	1650/1710	2.351-16	3.750	3.000	CF 6-1-4571 <i>Hub machined for speedometer gear and no.3 woodruff keyway</i>
1	1710	2.351-16	3.750	5.188	EY 6-4-4531■
1	1710	2.350-16	3.750	5.188	EY 6-4-5341■
1	1810	2.350-16	3.750	5.562	EY 6.5-4-3011■

1107-2A, 1107-3A, 1207

1	1610	2.635-20	3.750	5.062	EY 5-4-6531-1■
1	1710	2.635-20	3.750	5.188	EY 6-4-5351■

Pos	Series	Spline Data	Hub Dia	* to End of Hub	End Fitting Part Number
-----	--------	-------------	---------	-----------------	-------------------------

1107-2A, 1107-3A, 1207 (Continued)

1	1710	2.635-20	3.750	5.188	EY 6-4-7071-1X■ <i>Grnd.hub Dia. 3.000, if used on Spicer 1241 Aux. Trans.■</i>
1	1710	2.635-20	3.750	5.188	EY 6-4-7071X■ <i>Grnd.hub Dia. 3.000, if used on Spicer 1241 Aux. Trans.■</i>
1	1760	2.635-20	3.750	5.562	EY 6.3-4-41■ <i>Grnd.hub Dia. 3.000, if used on Spicer 1241 Aux. Trans.</i>
1	1760	2.635-20	3.750	5.562	EY 6.3-4-41-1■ <i>Grnd.hub Dia. 3.000, if used on Spicer 1241 Aux. Trans.</i>
1	1760	2.635-20	3.750	5.562	EY 6.3-4-871-1X■ <i>Grnd.hub Dia. 3.000, if used on Spicer 1241 Aux. Trans.</i>
1	1760	2.635-20	3.750	5.562	EY 6.3-4-871X■ <i>Grnd.hub Dia. 3.000, if used on Spicer 1241 Aux. Trans.</i>
1	1810	2.635-20	3.750	5.562	EY 6.5-4-2011■
1	1810	2.635-20	3.750	5.562	EY 6.5-4-3021■ <i>Grnd.hub Dia. 3.000, if used on Spicer 1241 Aux. Trans.</i>
1	1810	2.635-20	3.750	5.562	EY 6.5-4-3021-1■ <i>Grnd.hub Dia. 3.000, if used on Spicer 1241 Aux. Trans.</i>
1	1810	2.635-20	3.750	5.562	EY 6.5-4-3541-1X■ <i>Grnd.hub Dia. 3.000, if used on Spicer 1241 Aux. Trans.</i>
1	1810	2.635-20	3.750	5.562	EY 6.5-4-3541X■ <i>Grnd.hub Dia. 3.000, if used on Spicer 1241 Aux. Trans.</i>

1211, 1211-3A, 1211-5A, 1212

1	1610	2.635-20	3.750	5.062	EY 5-4-6531-1■
1	1710	2.635-20	3.750	5.188	EY 6-4-7071-1X■ <i>Grnd.hub Dia. 3.000, if used on Spicer 1241 Aux. Trans.■</i>
1	1710	2.635-20	3.750	5.188	EY 6-4-7071X■ <i>Grnd.hub Dia. 3.000, if used on Spicer 1241 Aux. Trans.■</i>
1	1760	2.635-20	3.750	5.562	EY 6.3-4-41■ <i>Grnd.hub Dia. 3.000, if used on Spicer 1241 Aux. Trans.</i>
1	1760	2.635-20	3.750	5.562	EY 6.3-4-41-1■ <i>Grnd.hub Dia. 3.000, if used on Spicer 1241 Aux. Trans.</i>
1	1760	2.635-20	3.750	5.562	EY 6.3-4-871-1X■ <i>Grnd.hub Dia. 3.000, if used on Spicer 1241 Aux. Trans.</i>
1	1760	2.635-20	3.750	5.562	EY 6.3-4-871X■ <i>Grnd.hub Dia. 3.000, if used on Spicer 1241 Aux. Trans.</i>
1	1810	2.635-20	3.750	5.562	EY 6.5-4-2011■
1	1810	2.635-20	3.750	5.562	EY 6.5-4-3021■ <i>Grnd.hub Dia. 3.000, if used on Spicer 1241 Aux. Trans.</i>
1	1810	2.635-20	3.750	5.562	EY 6.5-4-3021-1■ <i>Grnd.hub Dia. 3.000, if used on Spicer 1241 Aux. Trans.</i>
1	1810	2.635-20	3.750	5.562	EY 6.5-4-3541-1X■ <i>Grnd.hub Dia. 3.000, if used on Spicer 1241 Aux. Trans.</i>
1	1810	2.635-20	3.750	5.562	EY 6.5-4-3541X■ <i>Grnd.hub Dia. 3.000, if used on Spicer 1241 Aux. Trans.</i>

*C/L to End of Hub for EY (End Yoke); Flange Face to End of Hub for CF (Companion Flange)

■ Hub machined for speedometer gear



Pos	Series	Spline Data	Hub Dia	* to End of Hub	End Fitting Part Number
1214					
1	1610	2.635-20	3.750	5.062	EY 5-4-6531-1■
1	1710	2.635-20	3.750	5.188	EY 6-4-5351■
1	1710	2.635-20	3.750	5.188	EY 6-4-7071-1X
	<i>Grnd.hub Dia. 3.000, if used on Spicer 1241 Aux. Trans.■</i>				
1	1710	2.635-20	3.750	5.188	EY 6-4-7071X
	<i>Grnd.hub Dia. 3.000, if used on Spicer 1241 Aux. Trans.■</i>				
1	1760	2.635-20	3.750	5.562	EY 6.3-4-41■
	<i>Grnd.hub Dia. 3.000, if used on Spicer 1241 Aux. Trans.</i>				
1	1760	2.635-20	3.750	5.562	EY 6.3-4-41-1■
	<i>Grnd.hub Dia. 3.000, if used on Spicer 1241 Aux. Trans.</i>				
1	1760	2.635-20	3.750	5.562	EY 6.3-4-871-1X■
	<i>Grnd.hub Dia. 3.000, if used on Spicer 1241 Aux. Trans.</i>				
1	1760	2.635-20	3.750	5.562	EY 6.3-4-871X■
	<i>Grnd.hub Dia. 3.000, if used on Spicer 1241 Aux. Trans.</i>				
1	1810	2.635-20	3.750	5.562	EY 6.5-4-2011■
1	1810	2.635-20	3.750	5.562	EY 6.5-4-3021■
	<i>Grnd.hub Dia. 3.000, if used on Spicer 1241 Aux. Trans.</i>				
1	1810	2.635-20	3.750	5.562	EY 6.5-4-3021-1■
	<i>Grnd.hub Dia. 3.000, if used on Spicer 1241 Aux. Trans.</i>				
1	1810	2.635-20	3.750	5.562	EY 6.5-4-3541-1X■
	<i>Grnd.hub Dia. 3.000, if used on Spicer 1241 Aux. Trans.</i>				
1	1810	2.635-20	3.750	5.562	EY 6.5-4-3541X■
	<i>Grnd.hub Dia. 3.000, if used on Spicer 1241 Aux. Trans.</i>				

1252,					
1	1650/1710	2.351-16	3.750	3.000	CF 6-1-4571
	<i>Hub machined for speedometer gear and no.3 woodruff keyway</i>				
1	1710	2.351-16	3.750	5.188	EY 6-4-4531■
1	1710	2.350-16	3.750	5.188	EY 6-4-5341■
1	1810	2.350-16	3.750	5.562	EY 6.5-4-3011■

1252A, 1253, 1253A, 1253B, 1254, 1254A, 1262, 1262A, 1263, 1263A, 1264, 1264A, 1265, 1265A					
1	1650/1710	2.351-16	3.750	3.000	CF 6-1-4571
	<i>Hub machined for speedometer gear and no.3 woodruff keyway</i>				
1	1710	2.351-16	3.750	5.188	EY 6-4-4531■
1	1710	2.350-16	3.750	5.188	EY 6-4-5341■
1	1810	2.350-16	3.750	5.562	EY 6.5-4-3011■

1272, 1274-A, 1310					
1	1610	2.635-20	3.750	5.062	EY 5-4-6531-1■
1	1710	2.635-20	3.750	5.188	EY 6-4-5351■
1	1710	2.635-20	3.750	5.188	EY 6-4-7071-1X
	<i>Grnd.hub Dia. 3.000, if used on Spicer 1241 Aux. Trans.■</i>				
1	1710	2.635-20	3.750	5.188	EY 6-4-7071X
	<i>Grnd.hub Dia. 3.000, if used on Spicer 1241 Aux. Trans.■</i>				
1	1760	2.635-20	3.750	5.562	EY 6.3-4-41■
	<i>Grnd.hub Dia. 3.000, if used on Spicer 1241 Aux. Trans.</i>				
1	1760	2.635-20	3.750	5.562	EY 6.3-4-41-1■
	<i>Grnd.hub Dia. 3.000, if used on Spicer 1241 Aux. Trans.</i>				
1	1760	2.635-20	3.750	5.562	EY 6.3-4-871-1X■
	<i>Grnd.hub Dia. 3.000, if used on Spicer 1241 Aux. Trans.</i>				
1	1760	2.635-20	3.750	5.562	EY 6.3-4-871X■
	<i>Grnd.hub Dia. 3.000, if used on Spicer 1241 Aux. Trans.</i>				
1	1810	2.635-20	3.750	5.562	EY 6.5-4-2011■
1	1810	2.635-20	3.750	5.562	EY 6.5-4-3021■
	<i>Grnd.hub Dia. 3.000, if used on Spicer 1241 Aux. Trans.</i>				
1	1810	2.635-20	3.750	5.562	EY 6.5-4-3021-1■
	<i>Grnd.hub Dia. 3.000, if used on Spicer 1241 Aux. Trans.</i>				
1	1810	2.635-20	3.750	5.562	EY 6.5-4-3541-1X■
	<i>Grnd.hub Dia. 3.000, if used on Spicer 1241 Aux. Trans.</i>				
1	1810	2.635-20	3.750	5.562	EY 6.5-4-3541X■
	<i>Grnd.hub Dia. 3.000, if used on Spicer 1241 Aux. Trans.</i>				

Pos	Series	Spline Data	Hub Dia	* to End of Hub	End Fitting Part Number
1352					
1	1610	2.635-20	3.750	5.062	EY 5-4-6531-1■
1	1710	2.635-20	3.750	5.188	EY 6-4-7071-1X
	<i>Grnd.hub Dia. 3.000, if used on Spicer 1241 Aux. Trans.■</i>				
1	1710	2.635-20	3.750	5.188	EY 6-4-7071X
	<i>Grnd.hub Dia. 3.000, if used on Spicer 1241 Aux. Trans.■</i>				
1	1760	2.635-20	3.750	5.562	EY 6.3-4-41■
	<i>Grnd.hub Dia. 3.000, if used on Spicer 1241 Aux. Trans.</i>				
1	1760	2.635-20	3.750	5.562	EY 6.3-4-41-1■
	<i>Grnd.hub Dia. 3.000, if used on Spicer 1241 Aux. Trans.</i>				
1	1760	2.635-20	3.750	5.562	EY 6.3-4-871-1X■
	<i>Grnd.hub Dia. 3.000, if used on Spicer 1241 Aux. Trans.</i>				
1	1760	2.635-20	3.750	5.562	EY 6.3-4-871X■
	<i>Grnd.hub Dia. 3.000, if used on Spicer 1241 Aux. Trans.</i>				
1	1810	2.635-20	3.750	5.562	EY 6.5-4-2011■
1	1810	2.635-20	3.750	5.562	EY 6.5-4-3021■
	<i>Grnd.hub Dia. 3.000, if used on Spicer 1241 Aux. Trans.</i>				
1	1810	2.635-20	3.750	5.562	EY 6.5-4-3021-1■
	<i>Grnd.hub Dia. 3.000, if used on Spicer 1241 Aux. Trans.</i>				
1	1810	2.635-20	3.750	5.562	EY 6.5-4-3541-1X■
	<i>Grnd.hub Dia. 3.000, if used on Spicer 1241 Aux. Trans.</i>				
1	1810	2.635-20	3.750	5.562	EY 6.5-4-3541X■
	<i>Grnd.hub Dia. 3.000, if used on Spicer 1241 Aux. Trans.</i>				

1362, 1364					
1	1610	2.635-20	3.750	5.062	EY 5-4-6531-1■
1	1710	2.635-20	3.750	5.188	EY 6-4-5351■
1	1710	2.635-20	3.750	5.188	EY 6-4-5351-1■
1	1710	2.635-20	3.750	5.188	EY 6-4-7071-1X
	<i>Grnd.hub Dia. 3.000, if used on Spicer 1241 Aux. Trans.■</i>				
1	1710	2.635-20	3.750	5.188	EY 6-4-7071X
	<i>Grnd.hub Dia. 3.000, if used on Spicer 1241 Aux. Trans.■</i>				
1	1760	2.635-20	3.750	5.562	EY 6.3-4-41■
	<i>Grnd.hub Dia. 3.000, if used on Spicer 1241 Aux. Trans.</i>				
1	1760	2.635-20	3.750	5.562	EY 6.3-4-41-1■
	<i>Grnd.hub Dia. 3.000, if used on Spicer 1241 Aux. Trans.</i>				
1	1760	2.635-20	3.750	5.562	EY 6.3-4-871-1X■
	<i>Grnd.hub Dia. 3.000, if used on Spicer 1241 Aux. Trans.</i>				
1	1760	2.635-20	3.750	5.562	EY 6.3-4-871X■
	<i>Grnd.hub Dia. 3.000, if used on Spicer 1241 Aux. Trans.</i>				
1	1810	2.635-20	3.750	5.562	EY 6.5-4-2011■
1	1810	2.635-20	3.750	5.562	EY 6.5-4-3021■
	<i>Grnd.hub Dia. 3.000, if used on Spicer 1241 Aux. Trans.</i>				
1	1810	2.635-20	3.750	5.562	EY 6.5-4-3021-1■
	<i>Grnd.hub Dia. 3.000, if used on Spicer 1241 Aux. Trans.</i>				
1	1810	2.635-20	3.750	5.562	EY 6.5-4-3541-1X■
	<i>Grnd.hub Dia. 3.000, if used on Spicer 1241 Aux. Trans.</i>				
1	1810	2.635-20	3.750	5.562	EY 6.5-4-3541X■
	<i>Grnd.hub Dia. 3.000, if used on Spicer 1241 Aux. Trans.</i>				

1372					
1	1610	2.635-20	3.750	5.062	EY 5-4-6531-1■
1	1710	2.635-20	3.750	5.188	EY 6-4-5351■
1	1710	2.635-20	3.750	5.188	EY 6-4-5351-1■
1	1710	2.635-20	3.750	5.188	EY 6-4-7071-1X
	<i>Grnd.hub Dia. 3.000, if used on Spicer 1241 Aux. Trans.■</i>				
1	1710	2.635-20	3.750	5.188	EY 6-4-7071X
	<i>Grnd.hub Dia. 3.000, if used on Spicer 1241 Aux. Trans.■</i>				
1	1760	2.544-49	4.000	5.562	EY 6.3-4-1251
1	1760	2.544-49	4.000	5.562	EY 6.3-4-1251-1
1	1760	2.635-20	3.750	5.562	EY 6.3-4-41■
	<i>Grnd.hub Dia. 3.000, if used on Spicer 1241 Aux. Trans.</i>				

Continued on next page

*C/L to End of Hub for EY (End Yoke); Flange Face to End of Hub for CF (Companion Flange)

■ Hub machined for speedometer gear



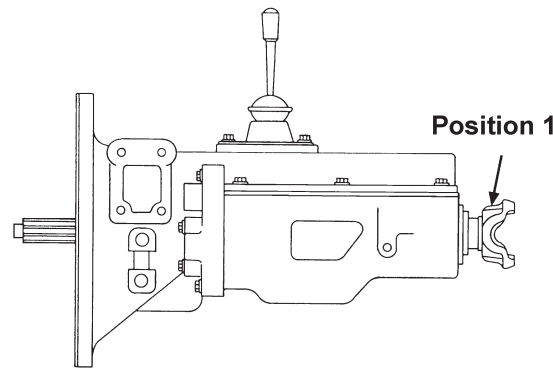

Pos	Series	Spline Data	Hub Dia	* to End of Hub	End Fitting Part Number
-----	--------	-------------	---------	-----------------	-------------------------

1372 (Continued)

1	1760	2.635-20	3.750	5.562	EY 6.3-4-41-1■ <i>Grnd.hub Dia. 3.000, if used on Spicer 1241 Aux. Trans.</i>
1	1760	2.635-20	3.750	5.562	EY 6.3-4-871-1X■ <i>Grnd.hub Dia. 3.000, if used on Spicer 1241 Aux. Trans.</i>
1	1760	2.635-20	3.750	5.562	EY 6.3-4-871X■ <i>Grnd.hub Dia. 3.000, if used on Spicer 1241 Aux. Trans.</i>
1	1810	2.635-20	3.750	5.562	EY 6.5-4-2011■
1	1810	2.635-20	3.750	5.562	EY 6.5-4-3021■ <i>Grnd.hub Dia. 3.000, if used on Spicer 1241 Aux. Trans.</i>
1	1810	2.635-20	3.750	5.562	EY 6.5-4-3021-1■ <i>Grnd.hub Dia. 3.000, if used on Spicer 1241 Aux. Trans.</i>
1	1810	2.635-20	3.750	5.562	EY 6.5-4-3541-1X■ <i>Grnd.hub Dia. 3.000, if used on Spicer 1241 Aux. Trans.</i>
1	1810	2.635-20	3.750	5.562	EY 6.5-4-3541X■ <i>Grnd.hub Dia. 3.000, if used on Spicer 1241 Aux. Trans.</i>

1414

1	1610	2.635-20	3.750	5.062	EY 5-4-6531-1■
1	1710	2.635-20	3.750	5.188	EY 6-4-5351■
1	1710	2.635-20	3.750	5.188	EY 6-4-5351-1■
1	1710	2.635-20	3.750	5.188	EY 6-4-7071-1X
1	1710	2.635-20	3.750	5.188	EY 6-4-7071X■ <i>Grnd.hub Dia. 3.000, if used on Spicer 1241 Aux. Trans.</i>
1	1760	2.635-20	3.750	5.562	EY 6.3-4-41■ <i>Grnd.hub Dia. 3.000, if used on Spicer 1241 Aux. Trans.</i>
1	1760	2.635-20	3.750	5.562	EY 6.3-4-41-1■ <i>Grnd.hub Dia. 3.000, if used on Spicer 1241 Aux. Trans.</i>
1	1760	2.635-20	3.750	5.562	EY 6.3-4-871-1X■ <i>Grnd.hub Dia. 3.000, if used on Spicer 1241 Aux. Trans.</i>
1	1760	2.635-20	3.750	5.562	EY 6.3-4-871X■ <i>Grnd.hub Dia. 3.000, if used on Spicer 1241 Aux. Trans.</i>
1	1810	2.635-20	3.750	5.562	EY 6.5-4-2011■
1	1810	2.635-20	3.750	5.562	EY 6.5-4-3021■ <i>Grnd.hub Dia. 3.000, if used on Spicer 1241 Aux. Trans.</i>
1	1810	2.635-20	3.750	5.562	EY 6.5-4-3021-1■ <i>Grnd.hub Dia. 3.000, if used on Spicer 1241 Aux. Trans.</i>
1	1810	2.635-20	3.750	5.562	EY 6.5-4-3541-1X■ <i>Grnd.hub Dia. 3.000, if used on Spicer 1241 Aux. Trans.</i>
1	1810	2.635-20	3.750	5.562	EY 6.5-4-3541X■ <i>Grnd.hub Dia. 3.000, if used on Spicer 1241 Aux. Trans.</i>

1420

1	1710	2.635-20	3.750	5.188	EY 6-4-5351■
1	1710	2.635-20	3.750	5.188	EY 6-4-5351-1■

Pos	Series	Spline Data	Hub Dia	* to End of Hub	End Fitting Part Number
-----	--------	-------------	---------	-----------------	-------------------------

1420-3A, 1420-3B

1	1610	2.635-20	3.750	5.062	EY 5-4-6531-1■
1	1710	2.635-20	3.750	5.188	EY 6-4-7071-1X
1	1710	2.635-20	3.750	5.188	EY 6-4-7071X■ <i>Grnd.hub Dia. 3.000, if used on Spicer 1241 Aux. Trans.</i>
1	1760	2.635-20	3.750	5.562	EY 6.3-4-41■ <i>Grnd.hub Dia. 3.000, if used on Spicer 1241 Aux. Trans.</i>
1	1760	2.635-20	3.750	5.562	EY 6.3-4-41-1■ <i>Grnd.hub Dia. 3.000, if used on Spicer 1241 Aux. Trans.</i>
1	1760	2.635-20	3.750	5.562	EY 6.3-4-871-1X■ <i>Grnd.hub Dia. 3.000, if used on Spicer 1241 Aux. Trans.</i>
1	1760	2.635-20	3.750	5.562	EY 6.3-4-871X■ <i>Grnd.hub Dia. 3.000, if used on Spicer 1241 Aux. Trans.</i>
1	1810	2.635-20	3.750	5.562	EY 6.5-4-2011■
1	1810	2.635-20	3.750	5.562	EY 6.5-4-3021■ <i>Grnd.hub Dia. 3.000, if used on Spicer 1241 Aux. Trans.</i>
1	1810	2.635-20	3.750	5.562	EY 6.5-4-3021-1■ <i>Grnd.hub Dia. 3.000, if used on Spicer 1241 Aux. Trans.</i>
1	1810	2.635-20	3.750	5.562	EY 6.5-4-3541-1X■ <i>Grnd.hub Dia. 3.000, if used on Spicer 1241 Aux. Trans.</i>
1	1810	2.635-20	3.750	5.562	EY 6.5-4-3541X■ <i>Grnd.hub Dia. 3.000, if used on Spicer 1241 Aux. Trans.</i>

1452, 1453, 1463

1	1610	2.635-20	3.750	5.062	EY 5-4-6531-1■
1	1710	2.635-20	3.750	5.188	EY 6-4-5351■
1	1710	2.635-20	3.750	5.188	EY 6-4-5351-1■
1	1710	2.635-20	3.750	5.188	EY 6-4-7071-1X
1	1710	2.635-20	3.750	5.188	EY 6-4-7071X■ <i>Grnd.hub Dia. 3.000, if used on Spicer 1241 Aux. Trans.</i>
1	1760	2.635-20	3.750	5.562	EY 6.3-4-41■ <i>Grnd.hub Dia. 3.000, if used on Spicer 1241 Aux. Trans.</i>
1	1760	2.635-20	3.750	5.562	EY 6.3-4-41-1■ <i>Grnd.hub Dia. 3.000, if used on Spicer 1241 Aux. Trans.</i>
1	1760	2.635-20	3.750	5.562	EY 6.3-4-871-1X■ <i>Grnd.hub Dia. 3.000, if used on Spicer 1241 Aux. Trans.</i>
1	1760	2.635-20	3.750	5.562	EY 6.3-4-871X■ <i>Grnd.hub Dia. 3.000, if used on Spicer 1241 Aux. Trans.</i>
1	1810	2.635-20	3.750	5.562	EY 6.5-4-2011■
1	1810	2.635-20	3.750	5.562	EY 6.5-4-3021■ <i>Grnd.hub Dia. 3.000, if used on Spicer 1241 Aux. Trans.</i>
1	1810	2.635-20	3.750	5.562	EY 6.5-4-3021-1■ <i>Grnd.hub Dia. 3.000, if used on Spicer 1241 Aux. Trans.</i>
1	1810	2.635-20	3.750	5.562	EY 6.5-4-3541-1X■ <i>Grnd.hub Dia. 3.000, if used on Spicer 1241 Aux. Trans.</i>
1	1810	2.635-20	3.750	5.562	EY 6.5-4-3541X■ <i>Grnd.hub Dia. 3.000, if used on Spicer 1241 Aux. Trans.</i>

*C/L to End of Hub for EY (End Yoke); Flange Face to End of Hub for CF (Companion Flange)

■ Hub machined for speedometer gear



Pos	Series	Spline Data	Hub Dia	* to End of Hub	End Fitting Part Number
3152, 3153, 3556, 3853					
1	1350/1410	1.500-10	2.250	2.375	CF 3-1-3191 <i>Can be used w/brake</i>
1	1480/1550	1.500-10	2.250	2.500	CF 4-1-3441 <i>Can be used w/brake</i>
5510					
1	1710	2.635-20	3.750	5.188	EY 6-4-5351■
1	1710	2.635-20	3.750	5.188	EY 6-4-5351-1■
5652, 5752, 5753, 5756, 5852, 5853					
1	1610	1.750-10	2.500	4.250	EY 5-4-1051
6241					
1	1480/1550	1.961-6	2.750	3.625	CF 4-1-601
6351					
	SPL90	2.000-10	2.750	4.969	EY 90-4-21-1
6352, 6354					
1	1550	2.000-10	2.750	3.625	CF 4-1-3781
1	1610	2.000-10	2.750	3.625	CF 5-1-3141
1	1650/1710	2.000-10	2.750	3.688	CF 6-1-2221
1	1610	2.000-10	2.750	5.188	EY 5-4-1661
1	1610	2.000-10	2.750	5.469	EY 5-4-1661-1
6440					
1	1480/1550	1.961-6	2.750	3.625	CF 4-1-601
6452, 6453, 6454, 6852, 6853, 6855, 7016, 7216					
1	1610	2.225-6	3.000	3.875	CF 5-1-2541
1	1650/1710	2.225-6	3.000	4.469	CF 6-1-1481
1	1650/1710	2.225-6	3.000	3.750	CF 6-1-1731
1	1810	2.225-6	3.000	3.750	CF 6.5-1-481
1	1710	2.225-6	3.000	5.438	EY 6-4-3041-1X
1	1710	2.225-6	3.000	5.312	EY 6-4-3041X
7352, 7452, 7453					
1	1550	2.000-10	2.750	3.625	CF 4-1-3781
1	1610	2.000-10	2.750	3.625	CF 5-1-3141
1	1650/1710	2.000-10	2.750	3.688	CF 6-1-2221
1	1610	2.000-10	2.750	5.188	EY 5-4-1661
1	1610	2.000-10	2.750	5.469	EY 5-4-1661-1
8012, 8016, 8041, 8045, 8051, 8052, 8054, 8055, 8212, 8216, 8241, 8245, 8251, 8252, 8255, 8440, 8445, 8512, 8516, 8542, 8545, 8553, 8554, 8555, 8716, 8742, 8744, 8753, 8755					
1	1610	2.225-6	3.000	3.875	CF 5-1-2541
1	1650/1710	2.225-6	3.000	4.469	CF 6-1-1481
1	1650/1710	2.225-6	3.000	3.750	CF 6-1-1731
1	1810	2.225-6	3.000	3.750	CF 6.5-1-481
1	1710	2.225-6	3.000	5.438	EY 6-4-3041-1X
1	1710	2.225-6	3.000	5.312	EY 6-4-3041X
9072					
1	1610	2.635-20	3.750	5.062	EY 5-4-6531-1■
1	1710	2.635-20	3.750	5.188	EY 6-4-7071-1X
	<i>Grnd.hub Dia. 3.000, if used on Spicer 1241 Aux. Trans.■</i>				
1	1710	2.635-20	3.750	5.188	EY 6-4-7071X
	<i>Grnd.hub Dia. 3.000, if used on Spicer 1241 Aux. Trans.■</i>				
1	1760	2.544-49	4.000	5.562	EY 6.3-4-1251
1	1760	2.544-49	4.000	5.562	EY 6.3-4-1251-1
1	1760	2.635-20	3.750	5.562	EY 6.3-4-41■
	<i>Grnd.hub Dia. 3.000, if used on Spicer 1241 Aux. Trans.</i>				
1	1760	2.635-20	3.750	5.562	EY 6.3-4-41-1■
	<i>Grnd.hub Dia. 3.000, if used on Spicer 1241 Aux. Trans.</i>				
1	1760	2.635-20	3.750	5.562	EY 6.3-4-871-1X■
	<i>Grnd.hub Dia. 3.000, if used on Spicer 1241 Aux. Trans.</i>				

Pos	Series	Spline Data	Hub Dia	* to End of Hub	End Fitting Part Number
9072 (Continued)					
1	1760	2.635-20	3.750	5.562	EY 6.3-4-871X■
	<i>Grnd.hub Dia. 3.000, if used on Spicer 1241 Aux. Trans.</i>				
1	1810	2.635-20	3.750	5.562	EY 6.5-4-2011■
1	1810	2.635-20	3.750	5.562	EY 6.5-4-3021■
	<i>Grnd.hub Dia. 3.000, if used on Spicer 1241 Aux. Trans.</i>				
1	1810	2.635-20	3.750	5.562	EY 6.5-4-3021-1■
	<i>Grnd.hub Dia. 3.000, if used on Spicer 1241 Aux. Trans.</i>				
1	1810	2.635-20	3.750	5.562	EY 6.5-4-3541-1X■
	<i>Grnd.hub Dia. 3.000, if used on Spicer 1241 Aux. Trans.</i>				
1	1810	2.635-20	3.750	5.562	EY 6.5-4-3541X■
	<i>Grnd.hub Dia. 3.000, if used on Spicer 1241 Aux. Trans.</i>				

*C/L to End of Hub for EY (End Yoke); Flange Face to End of Hub for CF (Companion Flange)

■ Hub machined for speedometer gear



Important: See Safety Information in General Information Section (J300P-GI)

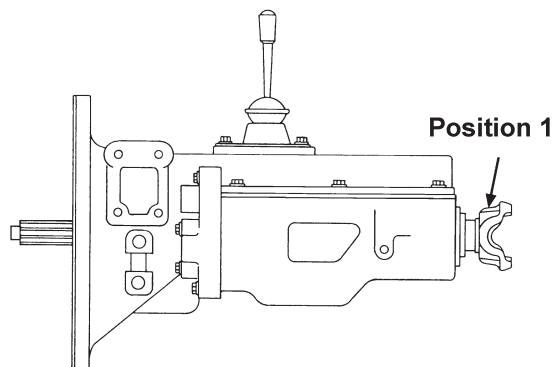

Pos	Series	Spline Data	Hub Dia	* to End of Hub	End Fitting Part Number
-----	--------	-------------	---------	-----------------	-------------------------

T-9, T-9L, T-87-D, T-97, T-98, T-98A,					
1	1350/1410	1.375-10	2.125	2.516	CF 3-1-2311
1	1350/1410	1.375-10	2.125	2.438	CF 3-1-751
1	1310	1.375-10	2.125	3.438	EY 2-4-1731
<i>Hub diameter not ground</i>					

Pos	Series	Spline Data	Hub Dia	* to End of Hub	End Fitting Part Number
-----	--------	-------------	---------	-----------------	-------------------------

TC-33					
	1410	1.750-10	2.375	4.188	EY 3-4-1161-1
	1550	1.750-10	2.375	4.000	EY 4-4-2041-1

TC-38					
1	1480	1.998-38	2.750	4.156	EY 3-4-8781-1
1	1550	1.998-38	2.750	4.035	EY 4-4-4491-1
<i>S/A 4-4-7341-1 But Hub does not Include Slinger Diameter</i>					
1	1610	1.998-38	2.750	4.125	EY 5-4-6321
1	1610	1.998-38	2.750	4.000	EY 5-4-6321-1
1	1710	1.998-38	2.750	5.250	EY 6-4-7301
1	1710	1.998-38	2.750	5.250	EY 6-4-7301-1
2	1480	1.998-38	2.750	4.156	EY 3-4-8781-1
2	1550	1.998-38	2.750	4.035	EY 4-4-4491-1
<i>S/A 4-4-7341-1 But Hub does not Include Slinger Diameter</i>					
2	1610	1.998-38	2.750	4.125	EY 5-4-6321
2	1610	1.998-38	2.750	4.000	EY 5-4-6321-1
2	1710	1.998-38	2.750	5.250	EY 6-4-7301
2	1710	1.998-38	2.750	5.250	EY 6-4-7301-1
3	1480	1.998-38	2.750	4.156	EY 3-4-8781-1
3	1550	1.998-38	2.750	4.035	EY 4-4-4491-1
<i>S/A 4-4-7341-1 But Hub does not Include Slinger Diameter</i>					
3	1610	1.998-38	2.750	4.125	EY 5-4-6321
3	1610	1.998-38	2.750	4.000	EY 5-4-6321-1
3	1710	1.998-38	2.750	5.250	EY 6-4-7301
3	1710	1.998-38	2.750	5.250	EY 6-4-7301-1

*C/L to End of Hub for EY (End Yoke); Flange Face to End of Hub for CF (Companion Flange)

■ Hub machined for speedometer gear



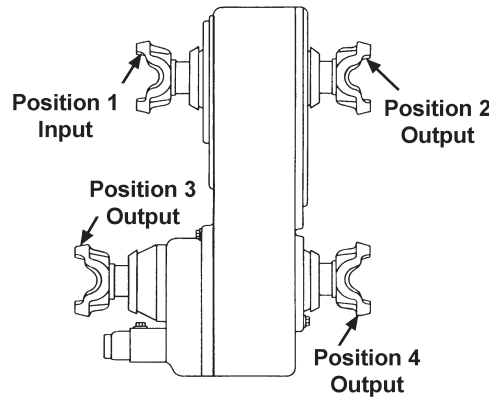

Pos	Series	Spline Data	Hub Dia	* to End of Hub	End Fitting Part Number
TC-44					
	1410	1.750-10	2.375	4.188	EY 3-4-1161-1
	1550	1.750-10	2.375	4.000	EY 4-4-2041-1

Pos	Series	Spline Data	Hub Dia	* to End of Hub	End Fitting Part Number
TC-140					
2	1810	2.750-10	3.500	6.062	EY 6.5-4-2931X
3	1610	1.964-10	2.625	4.500	EY 6-4-2211 <i>Chamfered Counterbore</i>
3	1710	1.962-10	2.625	4.500	EY 6-4-4731-1X <i>Chamfered Counterbore</i>
3	1710	1.962-10	2.625	4.500	EY 6-4-4731X <i>Chamfered Counterbore</i>

Pos	Series	Spline Data	Hub Dia	* to End of Hub	End Fitting Part Number
TC-142					
1	SPL250	2.750-10	3.500	6.312	EY 250-4-761-1X
1	1710	2.750-10	3.500	5.750	EY 6-4-4551
1	1710	2.750-10	3.500	5.750	EY 6-4-4551-1
1	1810	2.750-10	3.500	6.062	EY 6.5-4-1901
1	1810	2.750-10	3.500	6.062	EY 6.5-4-1901-1
2	SPL250	2.750-10	3.500	6.312	EY 250-4-761-1X
2	1710	2.750-10	3.500	5.750	EY 6-4-4551
2	1710	2.750-10	3.500	5.750	EY 6-4-4551-1
2	1810	2.750-10	3.500	6.062	EY 6.5-4-1901
2	1810	2.750-10	3.500	6.062	EY 6.5-4-1901-1
3	1810	2.500-10	3.500	5.406	EY 6.5-4-2101
3	1810	2.500-10	3.500	5.406	EY 6.5-4-2101-1

Pos	Series	Spline Data	Hub Dia	* to End of Hub	End Fitting Part Number
TC-143					
1	SPL250	2.750-10	3.500	6.312	EY 250-4-761-1X
1	1710	2.750-10	3.500	5.750	EY 6-4-4551
1	1710	2.750-10	3.500	5.750	EY 6-4-4551-1
1	1810	2.750-10	3.500	6.062	EY 6.5-4-1901
1	1810	2.750-10	3.500	6.062	EY 6.5-4-1901-1
2	SPL250	2.750-10	3.500	6.312	EY 250-4-751-1
2	SPL250	2.750-10	3.500	6.312	EY 250-4-761-1X
2	1710	2.750-10	3.500	5.750	EY 6-4-4551
2	1710	2.750-10	3.500	5.750	EY 6-4-4551-1
2	1810	2.750-10	3.500	6.062	EY 6.5-4-1901
2	1810	2.750-10	3.500	6.062	EY 6.5-4-1901-1
3	SPL250	2.750-10	3.500	6.312	EY 250-4-761-1X
3	1710	2.750-10	3.500	5.750	EY 6-4-4551
3	1710	2.750-10	3.500	5.750	EY 6-4-4551-1
3	1810	2.750-10	3.500	6.062	EY 6.5-4-1901
3	1810	2.750-10	3.500	6.062	EY 6.5-4-1901-1

Pos	Series	Spline Data	Hub Dia	* to End of Hub	End Fitting Part Number
TC-170					
1	SPL170	2.500-10	3.500	5.188	EY 170-4-1341-1
1	SPL250	2.500-10	3.500	5.500	EY 250-4-701-1
1	1710	2.500-10	3.500	5.156	EY 6-4-4421

Pos	Series	Spline Data	Hub Dia	* to End of Hub	End Fitting Part Number
-----	--------	-------------	---------	-----------------	-------------------------

Pos	Series	Spline Data	Hub Dia	* to End of Hub	End Fitting Part Number
TC-170 (Continued)					
1	1710	2.500-10	3.500	5.156	EY 6-4-4421-1
1	1760	2.500-10	3.500	5.406	EY 6.3-4-151
1	1760	2.500-10	3.500	5.406	EY 6.3-4-151-1
1	1810	2.500-10	3.500	5.406	EY 6.5-4-2101
1	1810	2.500-10	3.500	5.406	EY 6.5-4-2101-1
2	SPL170	2.500-10	3.500	5.188	EY 170-4-1341-1
2	SPL250	2.500-10	3.500	5.500	EY 250-4-701-1
2	1710	2.500-10	3.500	5.156	EY 6-4-4421
2	1710	2.500-10	3.500	5.156	EY 6-4-4421-1
2	1760	2.500-10	3.500	5.406	EY 6.3-4-151
2	1760	2.500-10	3.500	5.406	EY 6.3-4-151-1
2	1810	2.500-10	3.500	5.406	EY 6.5-4-2101
2	1810	2.500-10	3.500	5.406	EY 6.5-4-2101-1
3	SPL170	2.500-10	3.500	5.188	EY 170-4-1341-1
3	SPL250	2.500-10	3.500	5.500	EY 250-4-701-1
3	1710	2.500-10	3.500	5.156	EY 6-4-4421
3	1710	2.500-10	3.500	5.156	EY 6-4-4421-1
3	1760	2.500-10	3.500	5.406	EY 6.3-4-151
3	1760	2.500-10	3.500	5.406	EY 6.3-4-151-1
3	1810	2.500-10	3.500	5.406	EY 6.5-4-2101
3	1810	2.500-10	3.500	5.406	EY 6.5-4-2101-1

Pos	Series	Spline Data	Hub Dia	* to End of Hub	End Fitting Part Number
TC-171					
1	1810	2.500-10	3.500	5.406	EY 6.5-4-2101-1
2	1810	2.500-10	3.500	5.406	EY 6.5-4-2101-1

Pos	Series	Spline Data	Hub Dia	* to End of Hub	End Fitting Part Number
TC-200					
1	SPL170	2.114-32	3.000	5.000	EY 170-4-891-1
1	SPL250	2.114-32	3.000	5.240	EY 250-4-411-1
1	1610	2.114-32	3.000	5.375	EY 5-4-5751
1	1610	2.114-32	3.000	5.375	EY 5-4-8601-1
1	1710	2.114-32	3.000	4.562	EY 6-4-5811
1	1710	2.114-32	3.000	4.562	EY 6-4-8671-1
1	1810	2.114-32	3.000	5.000	EY 6.5-4-4451-1
2	1710	2.364-36	3.000	5.438	EY 6-4-7201
2	1810	2.500-10	3.500	5.406	EY 6.5-4-2101-1
2	1810	2.364-36	3.000	5.438	EY 6.5-4-3161
2	1810	2.364-36	3.000	5.438	EY 6.5-4-4411-1
3	SPL170	2.114-32	3.000	5.000	EY 170-4-891-1
3	SPL250	2.114-32	3.000	5.240	EY 250-4-411-1
3	1610	2.114-32	3.000	5.375	EY 5-4-5751
3	1610	2.364-36	3.000	5.156	EY 5-4-7191
3	1610	2.114-32	3.000	5.375	EY 5-4-8601-1
3	1710	2.114-32	3.000	4.562	EY 6-4-5811
3	1710	2.364-36	3.000	5.438	EY 6-4-7201

Continued on next page

*C/L to End of Hub for EY (End Yoke); Flange Face to End of Hub for CF (Companion Flange)

■ Hub machined for speedometer gear



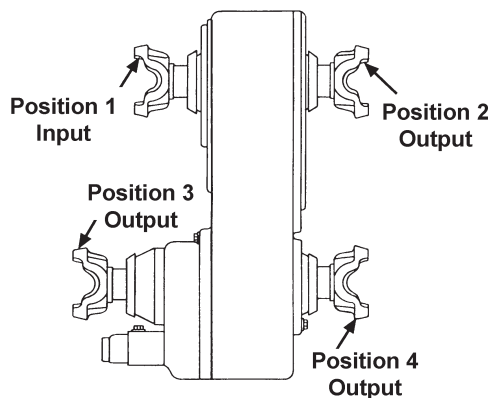

Pos	Series	Spline Data	Hub Dia	* to End of Hub	End Fitting Part Number
-----	--------	-------------	---------	-----------------	-------------------------

TC-200 (Continued)

3	1710	2.500-10	3.500	5.156	EY 6-4-8321-1X
3	1710	2.114-32	3.000	4.562	EY 6-4-8671-1
3	1710	2.364-36	3.000	5.438	EY 6-4-8711-1
3	1810	2.114-32	3.000	5.000	EY 6.5-4-4451-1

TC-270

1	SPL170	2.500-10	3.500	5.188	EY 170-4-1341-1
1	SPL250	2.500-10	3.500	5.500	EY 250-4-701-1
1	SPL250	2.750-10	3.500	6.312	EY 250-4-761-1X
1	1710	2.500-10	3.500	5.156	EY 6-4-4421
1	1710	2.750-10	3.500	5.750	EY 6-4-4551
1	1710	2.750-10	3.500	5.750	EY 6-4-4551-1
1	1760	2.500-10	3.500	5.406	EY 6.3-4-151
1	1760	2.500-10	3.500	5.406	EY 6.3-4-151-1
1	1760	2.500-10	3.500	5.156	EY 6-4-4421-1
1	1810	2.750-10	3.500	6.062	EY 6.5-4-1901
1	1810	2.750-10	3.500	6.062	EY 6.5-4-1901-1
1	1810	2.500-10	3.500	5.406	EY 6.5-4-2101
1	1810	2.500-10	3.500	5.406	EY 6.5-4-2101-1
2	SPL250	2.750-10	3.500	6.312	EY 250-4-751-1
2	1710	2.750-10	3.500	5.750	EY 6-4-4551
2	1710	2.750-10	3.500	5.750	EY 6-4-4551-1
2	1810	2.750-10	3.500	6.062	EY 6.5-4-1901
2	1810	2.750-10	3.500	6.062	EY 6.5-4-1901-1
3	SPL250	2.750-10	3.500	6.312	EY 250-4-761-1X
3	1710	2.750-10	3.500	5.750	EY 6-4-4551
3	1710	2.750-10	3.500	5.750	EY 6-4-4551-1
3	1810	2.750-10	3.500	6.062	EY 6.5-4-1901
3	1810	2.750-10	3.500	6.062	EY 6.5-4-1901-1

TC-1702

1	SPL170	2.500-10	3.500	5.188	EY 170-4-1341-1
1	SPL250	2.500-10	3.500	5.500	EY 250-4-701-1
1	1710	2.500-10	3.500	5.156	EY 6-4-4421
1	1710	2.500-10	3.500	5.156	EY 6-4-4421-1
1	1760	2.500-10	3.500	5.406	EY 6.3-4-151-1
1	1810	2.500-10	3.500	5.406	EY 6.5-4-2101
1	1810	2.500-10	3.500	5.406	EY 6.5-4-2101-1
2	SPL250	2.750-10	3.500	6.312	EY 250-4-751-1
2	1710	2.750-10	3.500	5.750	EY 6-4-4551
2	1710	2.750-10	3.500	5.750	EY 6-4-4551-1
2	1810	2.750-10	3.500	6.062	EY 6.5-4-1901
2	1810	2.750-10	3.500	6.062	EY 6.5-4-1901-1
3	SPL170	2.500-10	3.500	5.188	EY 170-4-1341-1
3	SPL250	2.500-10	3.500	5.500	EY 250-4-701-1
3	1710	2.500-10	3.500	5.156	EY 6-4-4421
3	1710	2.500-10	3.500	5.156	EY 6-4-4421-1

Pos	Series	Spline Data	Hub Dia	* to End of Hub	End Fitting Part Number
-----	--------	-------------	---------	-----------------	-------------------------

TC-1702 (Continued)

3	1760	2.500-10	3.500	5.406	EY 6.3-4-151-1
3	1810	2.500-10	3.500	5.406	EY 6.5-4-2101
3	1810	2.500-10	3.500	5.406	EY 6.5-4-2101-1

203, 205

1	1310	1.400-32	2.125	3.438	EY 2-4-4191-1
1	1350	1.401-32	2.125	3.500	EY 3-4-6211-1
2	1310	1.326-30	1.750	3.375	EY 2-4-5421X

MACK

TC15, TC25

1	SPL170	2.500-10	3.500	5.188	EY 170-4-1341-1
1	SPL170	2.500-10	3.500	5.188	EY 170-4-1351-1X
1	SPL250	2.500-10	3.500	5.500	EY 250-4-701-1
1	SPL250	2.500-10	3.500	5.500	EY 250-4-711-1X
1	1710	2.500-10	3.500	5.156	EY 6-4-4421
1	1710	2.500-10	3.500	5.156	EY 6-4-4421-1
1	1710	2.500-10	3.500	5.156	EY 6-4-8351-1X
1	1760	2.500-10	3.500	5.406	EY 6.3-4-1401-1X
1	1760	2.500-10	3.500	5.406	EY 6.3-4-1401X
1	1760	2.500-10	3.500	5.406	EY 6.3-4-151
1	1760	2.500-10	3.500	5.406	EY 6.3-4-151-1
1	1810	2.500-10	3.500	5.406	EY 6.5-4-2101
1	1810	2.500-10	3.500	5.406	EY 6.5-4-2101-1
1	1810	2.500-10	3.500	5.406	EY 6.5-4-2101-1X
1	1810	2.500-10	3.500	5.406	EY 6.5-4-4291X
2	SPL170	2.500-10	3.500	5.188	EY 170-4-1341-1
2	SPL250	2.500-10	3.500	5.500	EY 250-4-701-1
2	1710	2.500-10	3.500	5.156	EY 6-4-4421
2	1710	2.500-10	3.500	5.156	EY 6-4-4421-1
2	1760	2.500-10	3.500	5.406	EY 6.3-4-151
2	1760	2.500-10	3.500	5.406	EY 6.3-4-151-1
2	1810	2.500-10	3.500	5.406	EY 6.5-4-2101
2	1810	2.500-10	3.500	5.406	EY 6.5-4-2101-1
3	1710	2.260-6	3.250	5.300	EY 6-4-3501-1
3	1710	2.260-6	3.250	5.300	EY 6-4-8291-1X

NEW PROCESS

203, 205

2	1310	1.326-30	1.750	3.375	EY 2-4-5421X
---	------	----------	-------	-------	--------------

208

1	1310	1.401-32	1.875	3.875	EY 2-4-5341
1	1330	1.401-32	1.875	3.875	EY 2-4-5441

*C/L to End of Hub for EY (End Yoke); Flange Face to End of Hub for CF (Companion Flange)

■ Hub machined for speedometer gear



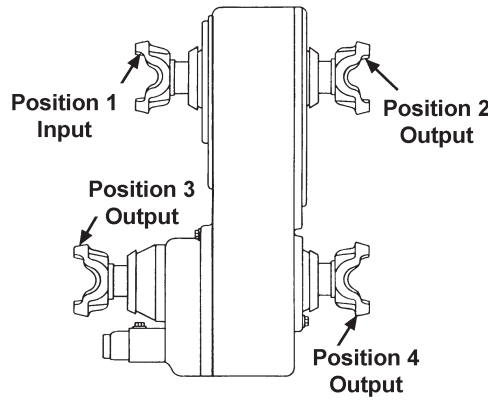

Pos	Series	Spline Data	Hub Dia	* to End of Hub	End Fitting Part Number
-----	--------	-------------	---------	-----------------	-------------------------

OSHKOSH

30000					
1	1710	2.390-46	3.250	5.125	EY 6-4-9531-1X

MERITOR/ROCKWELL

T-131, T-142					
2	1410	1.375-10	1.938	3.688	EY 3-4-1481-1

T-221					
2	1280/1310	1.250-10	1.750	3.625	EY 2-4-1831
2	1350	1.250-10	1.750	3.500	EY 3-4-3761-1

T-223					
1	1480	1.500-10	2.125	4.250	EY 3-4-6251
1	1480	1.500-10	2.125	4.250	EY 3-4-6261X
2	1350/1410	1.750-10	2.250	2.812	CF 3-1-3211
2	1410	1.750-10	2.250	4.188	EY 3-4-3351
2	1480	1.750-10	2.250	4.250	EY 3-4-6231-1
2	1480	1.750-10	2.250	4.250	EY 3-4-6241-1X
3	1480	1.500-10	2.125	4.250	EY 3-4-6251
3	1480	1.500-10	2.125	4.250	EY 3-4-6261X
4	1480	1.750-10	2.250	4.250	EY 3-4-6231-1
4	1480	1.750-10	2.250	4.250	EY 3-4-6241-1X

T-226					
2	1480	2.000-10	2.938	3.625	CF 4-1-2361
2	1610	2.000-10	2.938	3.625	CF 5-1-3161
2	1610	2.000-10	2.938	5.625	EY 5-4-1391
2	1610	2.000-10	2.938	5.000	EY 5-4-1521
2	1710	2.000-10	2.938	5.625	EY 6-4-2191

T-228					
1	1650/1710	2.250-10	3.000	3.750	CF 6-1-1421
1	1810	2.250-10	3.000	3.750	CF 6.5-1-211
<i>.250 deep counterbore at hub end</i>					
1	1610	2.250-10	3.000	5.625	EY 5-4-6891X
1	1710	2.250-10	3.000	6.062	EY 6-4-1991
1	1710	2.250-10	3.000	6.062	EY 6-4-1991-1
1	1710	2.250-10	3.000	6.062	EY 6-4-4411-1X
1	1710	2.250-10	3.000	6.062	EY 6-4-4411X
1	1710	2.250-10	3.000	7.188	EY 6-4-6891X
<i>High angle yoke</i>					
1	1760	2.250-10	3.000	5.844	EY 6.3-4-731-1X
1	1760	2.250-10	3.000	5.844	EY 6.3-4-731X
1	1810	2.250-10	3.000	5.844	EY 6.5-4-1911
2	1710	2.000-10	2.938	5.625	EY 6-4-2191

W/mechanical speedo pickup

Pos	Series	Spline Data	Hub Dia	* to End of Hub	End Fitting Part Number
-----	--------	-------------	---------	-----------------	-------------------------

MERITOR/ROCKWELL

T-77-3					
2	1480	2.000-10	2.938	3.625	CF 4-1-2361
2	1610	2.000-10	2.938	3.625	CF 5-1-3161
2	1610	2.000-10	2.938	5.625	EY 5-4-1391
2	1610	2.000-10	2.938	5.000	EY 5-4-1521
2	1710	2.000-10	2.938	5.625	EY 6-4-2191

SPICER®

18, 20					
1	1310	1.125-10	1.552	3.000	EY 2-4-2851-1X
2	1310	1.125-10	1.552	3.000	EY 2-4-2851-1X
3	1310	1.125-10	1.552	3.000	EY 2-4-2851-1X

23, 24					
1	1350/1410	1.375-10	2.125	2.438	CF 3-1-2011
1	1310	1.375-10	2.125	3.438	EY 2-4-1731
<i>Hub diameter not ground</i>					
2	1310	1.375-10	2.125	3.438	EY 2-4-1731
<i>Hub diameter not ground</i>					
3	1310	1.375-10	2.125	3.438	EY 2-4-1731
<i>Hub diameter not ground</i>					

300					
1	1310	1.146-26	1.554	2.594	CF 2-1-1881X
2	1310	1.146-26	1.554	2.594	CF 2-1-1881X
3	1310	1.146-26	1.554	2.594	CF 2-1-1881X

738-B, 738-C, 738-D, 738-E, 739-A					
1	1610	2.225-6	3.000	3.875	CF 5-1-2541
1	1650/1710	2.225-6	3.000	3.750	CF 6-1-1731
1	1810	2.225-6	3.000	3.750	CF 6.5-1-481
1	1610	2.225-6	3.000	5.719	EY 5-4-4751X
1	1710	2.225-6	3.000	5.312	EY 6-4-3041X
1	1760	2.225-6	3.000	6.000	EY 6.3-4-171-1X
1	1760	2.225-6	3.000	6.000	EY 6.3-4-171X
2	1610	2.225-6	3.000	3.875	CF 5-1-2541
2	1650/1710	2.225-6	3.000	3.750	CF 6-1-1731
2	1810	2.225-6	3.000	3.750	CF 6.5-1-481
2	1610	2.225-6	3.000	5.719	EY 5-4-4751X
2	1710	2.225-6	3.000	5.312	EY 6-4-3041X
2	1760	2.225-6	3.000	6.000	EY 6.3-4-171-1X
2	1760	2.225-6	3.000	6.000	EY 6.3-4-171X
3	1610	2.225-6	3.000	3.875	CF 5-1-2541

Continued on next page

*C/L to End of Hub for EY (End Yoke); Flange Face to End of Hub for CF (Companion Flange)

■ Hub machined for speedometer gear



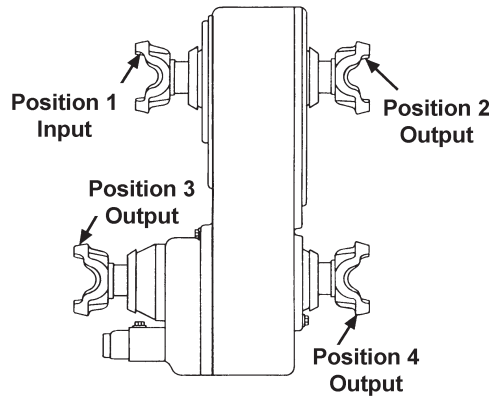

Pos	Series	Spline Data	Hub Dia	* to End of Hub	End Fitting Part Number
-----	--------	-------------	---------	-----------------	-------------------------

Pos	Series	Spline Data	Hub Dia	* to End of Hub	End Fitting Part Number
-----	--------	-------------	---------	-----------------	-------------------------

738-B, 738-C, 738-D, 738-E, 739-A (Continued)

3	1650/1710	2.225-6	3.000	3.750	CF 6-1-1731
3	1810	2.225-6	3.000	3.750	CF 6.5-1-481
3	1610	2.225-6	3.000	5.719	EY 5-4-4751X
3	1710	2.225-6	3.000	5.312	EY 6-4-3041X
3	1760	2.225-6	3.000	6.000	EY 6.3-4-171-1X
3	1760	2.225-6	3.000	6.000	EY 6.3-4-171X
4	1610	2.225-6	3.000	3.875	CF 5-1-2541
4	1650/1710	2.225-6	3.000	3.750	CF 6-1-1731
4	1810	2.225-6	3.000	3.750	CF 6.5-1-481
4	1610	2.225-6	3.000	5.719	EY 5-4-4751X
4	1710	2.225-6	3.000	5.312	EY 6-4-3041X
4	1760	2.225-6	3.000	6.000	EY 6.3-4-171-1X
4	1760	2.225-6	3.000	6.000	EY 6.3-4-171X

*C/L to End of Hub for EY (End Yoke); Flange Face to End of Hub for CF (Companion Flange)

■ Hub machined for speedometer gear



Part Number	Series	Splines Data		Ground Hub Dia.	Length Thru Hole	*C/L to End of Hub
		O.D.	No. Teeth			
2-1-1881X	1310	1.146	26	1.554	1.500	2.594
3-1-1151	1350	1.500	10	2.125	2.000	2.562
3-1-1521	1350	1.750	10	2.625	2.250	3.125
3-1-2011	1350	1.375	10	2.125	2.000	2.438
3-1-2311	1410	1.375	10	2.125	2.000	2.516
3-1-2431	1410	1.500	10	2.125	2.000	2.438
3-1-3191	1350	1.500	10	2.250	2.000	2.375
3-1-3211	1350	1.750	10	2.250	2.188	2.812
3-1-3431	1350	1.500	10	2.000	2.188	2.906
3-1-3531	1350	1.625	10	2.375	2.125	3.000
3-1-3881	1350	1.375	10	1.750	1.688	2.250
3-1-4041X	1350	1.276	29	1.875	1.500	2.062
3-1-751	1350	1.375	10	2.125	2.000	2.438
4-1-1381	1480	1.750	10	2.250	2.000	2.750
4-1-2361	1480	2.000	10	2.938	3.000	3.625
4-1-2661	1480	1.960	10	2.750	2.625	3.375
4-1-2701	1480	1.500	10	2.125	2.000	2.625
4-1-2751	1480	1.625	10	2.375	2.125	2.750
4-1-3101	1480	1.750	10	2.625	2.250	2.875
4-1-3171	1480	1.750	10	2.375	2.188	2.812
4-1-3331X	1480	1.750	10	2.500	2.250	2.875
4-1-3441	1480	1.500	10	2.250	2.000	2.500
4-1-3761	1480	1.964	10	2.500	2.250	3.000
4-1-3781	1480	2.000	10	2.750	3.000	3.625
4-1-3891	1480	1.750	10	2.500	2.250	3.000
4-1-4471	1480	1.790	34	2.562	2.750	3.344
4-1-4481X	1480	1.790	34	2.562	2.750	3.344
4-1-4491	1480	1.790	34	2.562	2.750	3.344
4-1-4501X	1480	1.790	34	2.562	2.750	3.344
4-1-5021	1480	1.998	38	2.750	2.125	2.875
4-1-5131	1480	1.750	10	2.500	1.938	2.734
4-1-5211X	1480	1.750	10	2.500	2.000	3.547
4-1-601	1480	1.961	06	2.750	3.000	3.625
4-1-6051X	1480	1.998	38	2.750	2.062	3.875
4-1-7001	1480	1.750	10	2.500	2.000	3.547
5-1-2541	1610	2.225	06	3.000	3.250	3.875
5-1-3141	1610	2.000	10	2.750	3.000	3.625
5-1-3161	1610	2.000	10	2.938	3.000	3.625
5-1-4291	1610	1.964	10	2.500	2.250	3.000
5-1-4301	1610	1.962	10	2.500	2.625	3.250
5-1-5111	1610	1.790	34	2.562	2.781	3.938
5-1-5121X	1610	1.790	34	2.562	2.781	3.938
5-1-5141	1610	1.790	34	2.562	2.750	4.250
5-1-5151X	1610	1.790	34	2.562	2.750	4.250
5-1-6271	1610	1.998	38	2.750	2.125	4.688
5-1-6331	1610	2.250	10	3.500	3.000	3.625
5-1-6471X	1610	1.998	38	2.750	2.125	4.688
5-1-6691	1610	2.114	32	3.000	2.245	2.844
5-1-6701X	1610	2.114	32	3.000	2.245	2.844
5-1-811	1610	1.750	10	2.625	2.250	2.875
5-1-931	1610	2.000	10	3.250	3.000	3.625
5008460	1610	2.544	49	3.818	2.125	3.130
5009516	1610	2.024	39	2.875	2.438	3.375
6.5-1-151	1810	2.250	10	3.500	3.000	3.688
6.5-1-1801	1810	2.364	18	3.500	3.375	4.031

Part Number	Series	Splines Data		Ground Hub Dia.	Length Thru Hole	*C/L to End of Hub
		O.D.	No. Teeth			
6.5-1-1871	1810	2.750	10	4.000	2.938	3.750
6.5-1-211	1810	2.250	10	3.000	3.000	3.750
6.5-1-2161	1810	2.560	20	3.500	3.344	4.000
6.5-1-2271	1810	2.500	10	3.750	3.000	3.625
6.5-1-2301	1810	2.364	18	2.750	2.328	3.000
6.5-1-2311	1810	2.750	10	3.750	3.000	4.062
6.5-1-2351X	1810	2.500	10	3.750	3.000	3.625
6.5-1-2361X	1810	2.750	10	3.750	3.000	4.062
6.5-1-2391	1810	2.274	44	2.938	2.500	3.094
6.5-1-2401X	1810	2.274	44	2.938	2.500	3.094
6.5-1-2441	1810	2.374	46	3.750	2.391	3.109
6.5-1-2941	1810	2.143	41	2.939	2.495	3.500
6.5-1-481	1810	2.225	06	3.000	3.250	3.750
6.5-1-741	1810	2.750	10	3.500	3.000	4.062
6-1-1421	1710	2.250	10	3.000	3.000	3.750
6-1-1461	1710	1.960	10	2.750	2.625	3.312
6-1-1481	1710	2.225	06	3.000	3.250	4.469
6-1-1731	1710	2.225	06	3.000	3.250	3.750
6-1-1761	1710	1.750	10	2.750	2.250	2.938
6-1-2221	1710	2.000	10	2.750	3.000	3.688
6-1-4541	1710	2.364	18	3.500	3.375	4.031
6-1-4571	1710	2.351	16	3.750	2.750	3.000
6-1-4671	1710	2.390	46	3.500	3.375	4.547
6-1-4691	1710	1.790	34	2.562	2.688	3.903
6-1-4701X	1710	1.790	34	2.562	2.688	3.903
6-1-5541	1710	2.500	10	3.750	3.000	3.625
6-1-5651X	1710	2.500	10	3.750	3.000	3.625
6-1-951	1710	2.250	10	3.500	3.000	3.688
90-1-11	SPL90	1.790	34	2.562	2.750	3.719
90-1-21X	SPL90	1.790	34	2.562	2.750	3.719

PART DATA LISTING

Part Number	Series	Splines Data		Ground Hub Dia.	Length Thru Hole	*C/L to End of Hub
		O.D.	No. Teeth			
100-4-02875-1X	SPL100	2.143	41	3.000	2.166	4.310
100-4-06608-1X	SPL100	2.024	39	3.000	1.817	4.150
100-4-07842-1	SPL100	1.790	34	3.000	1.812	6.063
100-4-1051-1	SPL100	2.143	41	2.938	2.500	4.562
100-4-1061-1X	SPL100	2.143	41	2.938	2.500	4.562
100-4-1071-1	SPL100	2.024	39	2.625	2.245	4.160
100-4-1081-1X	SPL100	2.024	39	2.625	2.245	4.160
100-4-1321-1	SPL100	2.024	39	2.625	2.245	7.295
100-4-1331-1X	SPL100	2.024	39	2.625	2.245	7.295
100-4-1341-1	SPL100	1.790	34	3.001	2.170	6.547
100-4-1351-1X	SPL100	1.790	34	3.001	2.170	6.547
100-4-1371-1X	SPL100	2.024	39	3.000	2.269	7.295
100-4-1381-1X	SPL90	2.281	44	2.938	2.344	4.469
100-4-1431-1X	SPL90	2.024	39	3.000	2.281	4.750
100-4-1451-1X	SPL100	2.024	39	3.000	2.250	6.062
100-4-1471-1X	SPL100	2.173	26	3.068	1.812	4.330
100-4-951-1	SPL100	2.024	39	3.000	2.284	4.750
100-4-961-1X	SPL100	2.024	39	3.000	2.284	4.750
131433K	SPL170	2.544	49	3.818	2.125	5.531
131434K	SPL170	2.544	49	3.818	2.125	6.260
131435K	SPL250	2.544	49	3.819	2.126	5.830
131437K	1710	2.544	49	3.819	2.125	5.570
131438K	1710	2.544	49	3.819	2.125	6.260
131439K	1710	2.544	49	3.819	2.125	6.260
131440K	1760	2.544	49	3.818	2.125	5.200
131441K	1760	2.544	49	3.818	2.125	5.200
131442K	1710	2.544	49	3.819	2.125	5.570
131443K	1810	2.544	49	3.818	2.141	5.740
131444K	1810	2.544	49	3.818	2.141	5.740
131446K	SPL250	2.544	49	3.819	2.672	6.200
131447K	1810	2.544	49	3.820	2.692	5.740
131448K	1810	2.544	49	3.819	2.677	5.740
131449K	1710	2.143	41	2.938	3.000	6.620
131450K	1710	2.143	41	2.938	3.000	6.620
131451K	SPL170	2.143	41	2.938	3.000	7.190
131519K	1710	2.544	49	3.819	2.677	6.050
131520K	1760	2.544	49	3.819	2.677	6.050
131530K	1710	2.544	49	3.819	2.677	6.050
132863K	SPL170	2.544	49	3.820	2.682	6.040
132931K	SPL170	2.544	49	3.820	2.675	6.812
140-4-03557-1X	SPL140	2.390	46	3.250	2.323	5.660
140-4-07494X	SPL140	2.024	39	3.000	1.817	4.470
140-4-1021-1	SPL140	1.998	38	2.750	2.125	7.728
140-4-1091-1	SPL140	2.250	10	3.500	3.000	6.000
140-4-1101-1X	SPL140	2.250	10	3.500	3.000	6.000
140-4-111-1	SPL140	1.998	38	2.750	2.125	4.830
140-4-1111-1	SPL140	2.500	10	3.750	3.000	5.960
140-4-1121-1X	SPL140	2.500	10	3.750	3.000	5.960
140-4-1131-1	SPL140	1.998	38	2.750	2.125	4.830
140-4-1151-1	SPL140	2.024	39	3.000	2.284	4.940
140-4-1161-1X	SPL140	2.024	39	3.000	2.284	4.940
140-4-1191-1	SPL140	2.274	44	2.938	2.344	5.190
140-4-1201-1X	SPL140	2.274	44	2.938	2.344	5.190
140-4-1231-1	SPL140	2.178	43	3.541	2.047	5.100
140-4-1261-1	SPL140	2.274	44	3.000	2.500	5.160

Part Number	Series	Splines Data		Ground Hub Dia.	Length Thru Hole	*C/L to End of Hub
		O.D.	No. Teeth			
140-4-1271-1X	SPL140	2.274	44	3.000	2.500	5.160
140-4-141-1	SPL140	2.544	49	3.750	3.000	5.570
140-4-1421-1	SPL140	2.024	39	2.750	2.435	5.250
140-4-1431-1X	SPL140	2.024	39	2.750	2.435	5.250
140-4-151-1X	SPL140	2.544	49	3.750	3.000	5.570
140-4-1601-1	SPL140	2.024	39	2.768	2.244	7.587
140-4-1611-1X	SPL140	2.024	39	2.768	2.244	7.587
140-4-1641-1X	SPL140	2.024	39	3.000	2.280	6.250
140-4-181-1	SPL140	1.962	10	2.750	2.805	5.810
140-4-201-1	SPL140	2.794	54		2.745	6.320
140-4-211-1	SPL140	2.024	39	3.000	2.312	5.680
140-4-231-1X	SPL140	2.024	39	3.000	2.312	5.680
140-4-241-1X	SPL140	2.024	39	3.000	2.312	5.680
140-4-251-1	SPL140	1.774	34	2.500	2.500	4.950
140-4-261-1X	SPL140	1.774	34	2.500	2.500	4.950
140-4-271-1	SPL140	2.374	46	3.250	2.875	6.210
140-4-291-1X	SPL140	2.374	46	3.250	2.875	6.210
140-4-301-1	SPL140	2.390	46	3.250	2.323	5.660
140-4-311-1X	SPL140	2.390	46	3.250	2.323	5.660
140-4-321-1	SPL140	2.274	44	3.000	2.500	5.160
140-4-331-1X	SPL140	2.274	44	3.000	2.500	5.160
140-4-361-1	SPL140	2.024	39	3.000	2.284	4.940
140-4-371-1X	SPL140	2.024	39	3.000	2.284	4.940
140-4-381-1	SPL140	2.390	46	3.375	3.195	6.440
140-4-391-1X	SPL140	2.390	46	3.375	3.195	6.440
140-4-41-1	SPL140	2.500	10	3.750	3.000	5.960
140-4-421-1	SPL140	2.143	41	2.938	2.500	5.560
140-4-431-1X	SPL140	2.143	41	2.938	2.500	5.560
140-4-441-1	SPL140	2.274	44	2.938	2.350	5.190
140-4-451-1X	SPL140	2.274	44	2.938	2.350	5.190
140-4-461-1	SPL140	1.790	34	2.625	2.188	4.870
140-4-471-1X	SPL140	1.790	34	2.625	2.188	4.870
140-4-491-1	SPL140	2.024	39	2.625	2.245	4.940
140-4-501-1X	SPL140	2.024	39	2.625	2.245	4.940
140-4-51-1X	SPL140	2.500	10	3.750	3.000	5.960
140-4-551-1	SPL140	2.024	39	2.625	2.250	5.030
140-4-561-1X	SPL140	2.024	39	2.625	2.250	5.030
140-4-61-1	SPL140	2.750	10	3.750	3.000	6.570
140-4-71-1X	SPL140	2.750	10	3.750	3.000	6.570
140-4-741-1X	SPL140	1.790	34	2.564	2.755	5.720
140-4-751-1	SPL140	2.390	46	3.500	3.375	5.920
140-4-761-1	SPL140	2.178	43	3.539	2.050	5.100
140-4-771-1	SPL140	2.795	55	4.725	2.047	4.980
140-4-81-1	SPL140	2.750	10	3.750	3.000	6.570
140-4-881-1	SPL140	2.544	49	4.000	2.750	6.060
140-4-891-1	SPL140	1.998	38	2.750	2.125	4.730
140-4-901-1	SPL140	1.998	38	3.000	2.125	4.680
140-4-91-1X	SPL140	2.750	10	3.750	3.000	6.570
140-4-911-1X	SPL140	1.998	38	3.000	2.125	4.680
140-4-921-1	SPL140	2.114	32	3.000	2.250	4.810
140-4-931-1X	SPL140	2.114	32	3.000	2.250	4.810
170-4-03558-1X	SPL170	2.390	46	3.250	2.328	5.100
170-4-03559-1X	SPL170	2.390	46	3.250	2.328	6.438
170-4-08444-1X	SPL170	2.544	49	3.820	2.682	6.040
170-4-08448-1X	SPL170	2.143	41	2.938	3.000	7.190

Part Number	Series	Spline Data		Ground Hub Dia.	Length Thru Hole	*C/L to End of Hub
		O.D.	No. Teeth			
170-4-08451-1X	SPL170	2.544	49	3.818	2.125	6.260
170-4-08458-1X	SPL170	2.544	49	3.820	2.125	5.531
170-4-08461-1X	SPL170	2.544	49	3.820	2.675	6.810
170-4-08577-1X	SPL170	2.024	39	3.000	2.281	5.540
170-4-08578-1X	SPL170	2.024	39	2.625	2.500	5.750
170-4-09705-1X	SPL170	1.774	34	2.500	2.250	6.440
170-4-101-1X	SPL170	2.274	44	2.938	2.500	5.281
170-4-1011-1	SPL170	2.364	36	3.000	2.685	5.470
170-4-1021-1X	SPL170	2.364	36	3.000	2.685	5.470
170-4-1031-1	SPL170	2.364	36	3.500	2.485	5.270
170-4-1041-1X	SPL170	2.364	36	3.500	2.485	5.270
170-4-1061-1	SPL170	2.364	18	3.500	3.375	6.350
170-4-1081-1	SPL170	2.178	43	3.540	2.050	5.340
170-4-1091-1	SPL170	2.795	55	4.725	2.047	5.200
170-4-1101-1	SPL170	2.635	20	3.750	2.750	6.020
170-4-111-1	SPL170	1.790	34	2.625	2.438	5.600
170-4-1111-1X	SPL170	2.635	20	3.750	2.750	6.020
170-4-1141-1	SPL170	2.750	10	4.000	2.935	5.800
170-4-1161-1	SPL170	2.544	49	4.000	2.750	6.050
170-4-1171-1	SPL170	2.374	46	3.750	2.406	5.190
170-4-1191-1X	SPL170	2.374	46	3.750	2.406	5.190
170-4-121-1X	SPL170	1.790	34	2.625	2.438	5.600
170-4-1211-1	SPL170	2.374	46	3.500	2.406	5.880
170-4-1221-1X	SPL170	2.374	46	3.500	2.406	5.880
170-4-1251-1	SPL170	2.024	39	2.750	2.000	5.370
170-4-1261-1X	SPL170	2.024	39	2.750	2.000	5.370
170-4-1281-1	SPL170	2.374	46	3.500	2.406	6.688
170-4-1291-1X	SPL170	2.374	46	3.500	2.406	6.688
170-4-1301-1	SPL170	2.250	10	3.312	2.250	5.620
170-4-131-1	SPL170	1.790	34	2.625	2.438	6.250
170-4-1311-1X	SPL170	2.250	10	3.312	2.250	5.620
170-4-1341-1	SPL170	2.500	10	3.500	2.406	5.188
170-4-1351-1X	SPL170	2.500	10	3.500	2.406	5.188
170-4-141-1X	SPL170	1.790	34	2.625	2.438	6.250
170-4-1441-1	SPL170	2.225	06	3.000	3.250	6.030
170-4-151-1	SPL170	2.024	39	2.625	2.250	4.938
170-4-161-1X	SPL170	2.024	39	2.625	2.250	4.938
170-4-1621-1	SPL170	2.024	39	3.000	2.281	6.240
170-4-1631-1X	SPL170	2.024	39	3.000	2.281	6.240
170-4-1641-1	SPL170	2.024	39	2.625	2.500	6.500
170-4-1651-1X	SPL170	2.024	39	2.625	2.500	6.500
170-4-1661-1	SPL170	2.274	44	3.000	2.500	5.270
170-4-1671-1X	SPL170	2.274	44	3.000	2.500	5.270
170-4-171-1	SPL170	2.024	39	2.625	2.250	6.016
170-4-1751-1X	SPL170	1.774	34	2.500	2.250	5.031
170-4-181-1X	SPL170	2.024	39	2.625	2.250	6.016
170-4-1861-1X	SPL170	2.143	41	2.938	3.000	7.190
170-4-1891-1	SPL170	2.544	49	3.820	2.125	5.531
170-4-191-1	SPL170	2.274	44	3.000	2.500	5.270
170-4-1931-1X	SPL170	2.750	43	3.750	1.792	5.929
170-4-1961-1X	SPL170	1.998	38	3.000	2.115	4.898
170-4-1991-1X	SPL170	2.024	39	3.000	2.281	5.156
170-4-2001-1X	SPL170	2.024	39	3.000	2.281	6.240
170-4-201-1X	SPL170	2.274	44	3.000	2.500	5.270
170-4-2011-1X	SPL170	2.274	44	3.000	2.500	5.270

Part Number	Series	Spline Data		Ground Hub Dia.	Length Thru Hole	*C/L to End of Hub
		O.D.	No. Teeth			
170-4-2021-1X	SPL170	2.544	49	3.820	2.125	5.531
170-4-2031-1X	SPL170	2.544	49	3.818	2.125	6.260
170-4-21-1	SPL170	2.274	44	2.938	2.350	5.094
170-4-211-1	SPL170	2.024	39	2.625	2.500	5.270
170-4-221-1X	SPL170	2.024	39	2.625	2.500	5.266
170-4-231-1	SPL170	2.024	39	2.625	2.500	6.500
170-4-241-1X	SPL170	2.024	39	2.625	2.500	6.500
170-4-251-1	SPL170	2.024	39	3.000	2.281	5.156
170-4-261-1X	SPL170	2.024	39	3.000	2.281	5.156
170-4-271-1	SPL170	2.024	39	3.000	2.281	6.240
170-4-281-1X	SPL170	2.024	39	3.000	2.281	6.240
170-4-291-1	SPL170	2.390	46	3.375	3.195	6.531
170-4-301-1X	SPL170	2.390	46	3.375	3.195	6.531
170-4-31-1X	SPL170	2.274	44	2.938	2.350	5.094
170-4-311-1	SPL170	2.143	41	2.938	3.000	7.190
170-4-321-1X	SPL170	2.143	41	2.938	3.000	7.190
170-4-331-1	SPL170	2.143	41	2.938	3.000	5.800
170-4-341-1X	SPL170	2.143	41	2.938	3.000	5.800
170-4-351-1	SPL170	2.143	41	2.938	2.500	5.320
170-4-361-1X	SPL170	2.143	41	2.938	2.500	5.320
170-4-371-1	SPL170	2.143	41	2.938	2.500	6.680
170-4-381-1X	SPL170	2.143	41	2.938	2.500	6.680
170-4-411-1	SPL170	2.544	49	3.750	3.000	6.000
170-4-421-1X	SPL170	2.544	49	3.750	3.000	6.000
170-4-451-1	SPL170	2.250	10	3.500	3.000	5.750
170-4-461-1X	SPL170	2.250	10	3.500	3.000	5.750
170-4-471-1	SPL170	2.500	10	3.750	3.000	5.750
170-4-481-1X	SPL170	2.500	10	3.750	3.000	5.750
170-4-491-1	SPL170	2.750	10	3.750	3.000	5.850
170-4-501-1X	SPL170	2.750	10	3.750	3.000	5.850
170-4-511-1	SPL170	2.750	10	3.750	3.000	5.850
170-4-521-1X	SPL170	2.750	10	3.750	3.000	5.850
170-4-531-1	SPL170	2.750	10	3.000	3.000	5.850
170-4-541-1	SPL170	1.998	38	2.750	2.125	4.844
170-4-561-1	SPL170	2.794	54	2.750	2.750	5.600
170-4-571-1	SPL170	2.374	46	3.250	2.875	5.760
170-4-581-1X	SPL170	2.374	46	3.250	2.875	5.760
170-4-591-1X	SPL170	2.374	46	3.250	2.875	5.760
170-4-601-1	SPL170	2.374	46	3.250	2.875	7.250
170-4-611-1X	SPL170	2.374	46	3.250	2.875	7.250
170-4-621-1	SPL170	1.774	34	2.500	2.250	5.031
170-4-631-1	SPL170	1.774	34	2.500	2.250	6.440
170-4-641-1	SPL170	2.024	39	3.000	2.312	5.090
170-4-651-1X	SPL170	2.024	39	3.000	2.312	5.090
170-4-661-1	SPL170	2.024	39	3.000	2.312	6.391
170-4-671-1X	SPL170	2.024	39	3.000	2.312	6.391
170-4-681-1X	SPL170	2.024	39	3.000	2.312	5.090
170-4-691-1X	SPL170	2.024	39	3.000	2.312	6.391
170-4-701-1X	SPL170	2.024	39	3.000	2.312	5.090
170-4-711-1	SPL170	2.390	46	3.250	2.328	5.100
170-4-721-1X	SPL170	2.390	46	3.250	2.328	5.100
170-4-731-1	SPL170	2.390	46	3.250	2.328	6.438
170-4-741-1X	SPL170	2.390	46	3.250	2.328	6.438
170-4-771-1	SPL170	1.989	30	3.000	2.685	6.580
170-4-781-1	SPL170	2.364	36	3.000	2.685	6.780

Part Number	Series	Splines Data		Ground Hub Dia.	Length Thru Hole	*C/L to End of Hub
		O.D.	No. Teeth			
170-4-791-1X	SPL170	2.364	36	3.000	2.685	6.780
170-4-801-1	SPL170	2.024	39	3.000	2.250	6.250
170-4-811-1X	SPL170	2.024	39	3.000	2.250	6.250
170-4-821-1	SPL170	2.024	39	3.000	2.500	5.280
170-4-831-1	SPL170	2.024	39	3.000	2.500	6.500
170-4-841-1	SPL170	2.024	39	3.000	2.250	5.031
170-4-851-1X	SPL170	2.024	39	3.000	2.250	5.031
170-4-861-1X	SPL170	2.024	39	3.000	2.250	5.031
170-4-891-1	SPL170	2.114	32	3.000	2.250	5.000
170-4-901-1X	SPL170	2.114	32	3.000	2.250	5.000
170-4-91-1	SPL170	2.274	44	2.938	2.500	5.281
170-4-921-1	SPL170	1.790	34	2.500	2.250	5.030
170-4-951-1	SPL170	2.114	32	3.000	2.250	6.312
170-4-961-1X	SPL170	2.114	32	3.000	2.250	6.312
2-4-1731	1310	1.375	10	2.125	2.000	3.438
2-4-1831	1310	1.250	10	1.750	2.000	3.625
2-4-2851-1X	1310	1.125	10	1.552	1.500	3.000
2-4-3581-1X	1330	1.146	26	1.552	1.500	3.000
2-4-3801-1X	1310	1.276	29	1.875	1.500	2.938
2-4-3801X	1310	1.276	29	1.875	1.500	2.938
2-4-4191-1	1310	1.400	32	2.125	2.000	3.438
2-4-4291-1X	1330	1.276	29	1.875	1.500	2.938
2-4-4601-1	1310	1.146	26	1.844	1.375	2.938
2-4-5251X	1310	1.146	26	1.552	1.500	3.406
2-4-5311X	1330-F	1.276	29	1.875	1.500	2.938
2-4-5341	1310	1.401	32	1.875	2.000	3.875
2-4-5421X	1310	1.326	30	1.750	2.000	3.375
2-4-5441	1330	1.401	32	1.875	2.000	3.875
2-4-6111X	1330-F	1.146	26	1.562	1.500	3.000
2-4-6131-1X	1310	1.026	23	1.552	1.500	3.000
2-4-6901-1X	1310	1.146	26	1.844	1.375	2.938
2-4-7631-1	1330	1.146	26	1.844	1.375	3.562
2-4-7661-1	7290	1.146	26	1.844	1.375	3.219
2-4-7681-1X	7290	1.276	29	1.875	1.500	3.359
2-4-8051X	1330-F	1.276	29	1.875	1.500	2.938
2-4-8091-1X	1310	1.146	26	1.552	1.500	3.000
2-4-8091X	1310	1.146	26	1.552	1.500	3.000
250-4-03560-1X	SPL250	2.390	46	3.250	2.312	5.312
250-4-08445-1X	SPL250	2.544	49	3.819	2.672	6.200
250-4-08459-1X	SPL250	2.544	49	3.819	2.125	5.830
250-4-101-1X	SPL250	2.390	46	3.375	3.195	6.760
250-4-1041-1X	SPL250	2.390	46	3.250	2.312	5.312
250-4-1061-1X	SPL250	2.750	43	3.750	1.790	5.500
250-4-1281-1X	SPL250	2.274	44	3.000	2.500	5.490
250-4-1291-1X	SPL250	2.544	49	3.861	2.677	6.200
250-4-1301-1X	SPL250	2.544	49	3.861	2.126	5.830
250-4-131-1	SPL250	2.143	41	2.938	2.500	5.490
250-4-1311-1X	SPL250	2.544	49	3.812	2.125	6.750
250-4-134705-1X	SPL250	2.544	49	3.861	2.677	6.200
250-4-141-1X	SPL250	2.143	41	2.938	2.500	5.490
250-4-151-1	SPL250	2.544	49	3.750	3.000	6.250
250-4-161-1X	SPL250	2.544	49	3.750	3.000	6.250
250-4-191-1	SPL250	2.500	10	3.750	3.000	6.062
250-4-201-1X	SPL250	2.500	10	3.750	3.000	6.062
250-4-211-1	SPL250	2.750	10	3.750	3.000	6.300

Part Number	Series	Splines Data		Ground Hub Dia.	Length Thru Hole	*C/L to End of Hub
		O.D.	No. Teeth			
250-4-221-1X	SPL250	2.750	10	3.750	3.000	6.300
250-4-231-1	SPL250	2.750	10	3.750	3.000	6.297
250-4-241-1X	SPL250	2.750	10	3.750	3.000	6.297
250-4-251-1	SPL250	2.750	10		3.000	6.310
250-4-271-1	SPL250	2.794	54		2.750	5.703
250-4-281-1	SPL250	2.374	46	3.250	2.875	5.870
250-4-291-1X	SPL250	2.374	46	3.250	2.875	5.870
250-4-301-1X	SPL250	2.374	46	3.250	2.875	5.870
250-4-31-1	SPL250	2.274	44	2.938	2.350	5.328
250-4-311-1	SPL250	2.024	39	3.000	2.312	5.300
250-4-321-1X	SPL250	2.024	39	3.000	2.312	5.300
250-4-341-1	SPL250	2.390	46	3.250	2.312	5.312
250-4-351-1X	SPL250	2.390	46	3.250	2.312	5.312
250-4-361-1	SPL250	2.364	36	3.000	2.685	5.680
250-4-371-1X	SPL250	2.364	36	3.000	2.685	5.680
250-4-381-1	SPL250	2.024	39	3.000	2.245	5.240
250-4-391-1X	SPL250	2.024	39	3.000	2.245	5.240
250-4-41-1X	SPL250	2.274	44	2.938	2.350	5.328
250-4-411-1	SPL250	2.114	32	3.000	2.245	5.240
250-4-421-1X	SPL250	2.114	32	3.000	2.245	5.240
250-4-471-1	SPL250	2.390	46	3.500	3.375	6.560
250-4-501-1	SPL250	2.795	55	4.725	2.047	5.413
250-4-51-1	SPL250	2.274	44	2.938	2.500	5.484
250-4-511-1	SPL250	2.635	20	3.750	2.750	6.270
250-4-521-1X	SPL250	2.635	20	3.750	2.750	6.270
250-4-531-1	SPL250	2.225	06	3.000	3.250	6.240
250-4-541-1X	SPL250	2.225	06	3.000	3.250	6.240
250-4-551-1	SPL250	2.750	10	4.000	2.935	6.370
250-4-561-1	SPL250	2.500	10	3.750	3.000	6.250
250-4-601-1	SPL250	2.374	46	3.750	2.406	5.410
250-4-61-1X	SPL250	2.274	44	2.938	2.500	5.484
250-4-621-1X	SPL250	2.374	46	3.750	2.406	5.410
250-4-641-1	SPL250	2.374	46	3.500	2.406	6.140
250-4-651-1X	SPL250	2.374	46	3.500	2.406	6.140
250-4-681-1	SPL250	2.250	10	3.125	2.250	5.234
250-4-691-1X	SPL250	2.250	10	3.125	2.250	5.234
250-4-701-1	SPL250	2.500	10	3.500	2.406	5.500
250-4-71-1	SPL250	2.274	44	3.000	2.500	5.490
250-4-711-1X	SPL250	2.500	10	3.500	2.406	5.500
250-4-751-1	SPL250	2.750	10	3.500	3.000	6.312
250-4-761-1X	SPL250	2.750	10	3.500	3.000	6.312
250-4-771-1	SPL250	2.374	46	3.250	2.625	5.610
250-4-781-1X	SPL250	2.374	46	3.250	2.625	5.610
250-4-791-1	SPL250	2.374	46	3.750	2.400	6.650
250-4-801-1X	SPL250	2.374	46	3.750	2.400	6.650
250-4-81-1X	SPL250	2.274	44	3.000	2.500	5.490
250-4-811-1	SPL250	2.225	06	3.000	3.250	6.250
250-4-901-1	SPL250	2.794	54	3.750	2.770	6.330
250-4-91-1	SPL250	2.390	46	3.375	3.195	6.760
250-4-921-1	SPL250	3.543	44	4.125	3.188	6.140
250-4-941-1	SPL250	2.795	55	4.725	2.047	5.410
250-4-951-1X	SPL250	2.795	55	4.725	2.047	5.410
3-4-06976-1X	1480	2.024	39	3.000	1.832	3.878
3-4-10251-1	1410	1.790	34	2.625	2.188	4.031
3-4-10261	1480	1.790	34	2.625	2.188	4.281

Part Number	Series	Spline Data		Ground Hub Dia.	Length Thru Hole	*C/L to End of Hub
		O.D.	No. Teeth			
3-4-10261-1	1480	1.790	34	2.625	2.188	4.281
3-4-10461-1X	1410	1.790	34	2.625	2.188	4.031
3-4-10471-1X	1480	1.790	34	2.625	2.188	4.281
3-4-11051-1	1480	2.024	39	2.625	2.250	4.344
3-4-11061-1X	1480	2.024	39	2.625	2.250	4.344
3-4-11081-1X	1410	1.609	37	2.500	2.000	4.312
3-4-11281-1X	1480	1.609	37	2.500	2.000	4.328
3-4-11551-1	1480	1.790	34	2.567	2.750	4.885
3-4-11561-1	1480	1.750	10	2.500	1.922	5.109
3-4-1161-1	1410	1.750	10	2.375	2.188	4.188
3-4-11621-1X	1480	1.790	34	2.567	2.750	4.885
3-4-11871-1	1480	1.750	10	2.500	1.938	4.000
3-4-11871-2	1480	1.750	10	2.500	1.938	4.000
3-4-11921-1X	1480	1.790	34	2.625	2.188	4.281
3-4-12091-1	1480	1.790	34	2.375	2.188	4.219
3-4-12101-1X	1480	1.790	34	2.375	2.188	4.219
3-4-12111-1	1480	1.998	38	3.000	2.125	4.281
3-4-12121-1X	1480	1.998	38	3.000	2.125	4.281
3-4-13051-1	1480	2.024	39	2.625	2.250	4.344
3-4-13061-1X	1480	2.024	39	2.625	2.250	4.344
3-4-13071-1	1480	2.024	39	3.000	2.281	4.344
3-4-13081-1X	1480	2.024	39	3.000	2.281	4.344
3-4-13341-1	1480	2.114	32	3.000	2.250	4.281
3-4-13351-1X	1480	2.114	32	3.000	2.250	4.281
3-4-14711-1X	1410	1.276	29	1.875	1.500	3.200
3-4-14731-1X	1480	1.609	37	2.500	2.000	4.328
3-4-14781-1	1480	2.024	39	3.000	1.832	3.878
3-4-14791-1X	1480	2.024	39	3.000	1.832	3.878
3-4-1481-1	1410	1.375	10	1.938	2.000	3.688
3-4-1841-1	1410	1.750	10	2.375	2.188	4.188
3-4-1911-1	1410	1.500	10	2.250	1.750	3.750
3-4-2241-1	1410	1.500	10	2.250	2.188	3.875
3-4-2271-1	1410	1.375	10	2.125	2.000	3.685
3-4-2351-1	1350	1.750	10	2.375	2.188	4.000
3-4-2511-1	1410	1.750	10	2.625	2.188	4.250
3-4-3121-1	1480	1.750	10	2.625	2.250	4.469
3-4-3241-1	1480	1.500	10	2.250	2.188	4.406
3-4-3291-1	1350	1.375	10	2.125	2.000	3.688
3-4-3351	1410	1.750	10	2.250	2.188	4.188
3-4-3491-1	1410	1.625	10	2.375	2.125	3.938
3-4-3571-1	1480	1.750	10	2.375	2.188	4.219
3-4-3761-1	1350	1.250	10	1.750	2.000	3.500
3-4-3771	1480	1.625	10	2.375	2.125	4.312
3-4-3781-1	1480	1.500	10	2.250	2.188	4.200
3-4-3941-1	1410	1.375	10	2.125	1.750	3.500
3-4-3961-1	1410	1.500	10	2.125	2.000	3.688
3-4-4211	1480	1.964	10	2.500	2.000	4.688
3-4-5191-1	1410	1.525	35	2.125	2.000	3.688
3-4-5711-1X	1410	1.276	29	1.875	1.500	3.188
3-4-5731-1X	1350	1.276	29	1.875	1.500	3.000
3-4-5791-1X	1480	1.750	10	2.625	2.250	4.281
3-4-5881-1X	1410	1.750	10	2.625	2.188	4.000
3-4-5921-1X	1410	1.625	10	2.375	2.125	4.188
3-4-6211-1	1350	1.401	32	2.125	2.000	3.500
3-4-6221-1X	1480	1.500	10	2.250	2.188	4.200

Part Number	Series	Spline Data		Ground Hub Dia.	Length Thru Hole	*C/L to End of Hub
		O.D.	No. Teeth			
3-4-6231-1	1480	1.750	10	2.250	2.188	4.250
3-4-6241-1X	1480	1.750	10	2.250	2.188	4.250
3-4-6251	1480	1.500	10	2.125	2.188	4.250
3-4-6261X	1480	1.500	10	2.125	2.188	4.250
3-4-6671-1X	1480	1.875	10	2.750	2.375	4.406
3-4-6691-1	1480	1.525	35	2.125	2.000	4.031
3-4-6701	1480	1.375	10	2.125	2.000	4.031
3-4-7131	1410	1.750	10	2.500	1.938	5.750
3-4-7151	1410	1.525	35	2.500	1.938	5.750
3-4-7161	1480	1.525	35	2.500	1.938	5.750
3-4-7241	1350	1.401	32	2.125	2.719	4.750
3-4-7241-1	1350	1.401	32	2.125	2.719	4.750
3-4-7541-1	1480	1.774	34	2.500	2.250	4.469
3-4-7551	1410	1.774	34	2.500	2.250	4.188
3-4-7551-1	1410	1.774	34	2.500	2.250	4.188
3-4-8051-1X	1480	1.774	34	2.500	2.250	4.469
3-4-8061-1X	1410	1.774	34	2.500	2.250	4.188
3-4-8061X	1410	1.774	34	2.500	2.250	4.188
3-4-8781-1	1480	1.998	38	2.750	2.125	4.156
3-4-8861	1480	2.024	39	3.000	2.312	4.281
3-4-8871X	1480	2.024	39	3.000	2.312	4.281
3-4-9001X	1350	1.625	10	2.375	2.125	3.969
3-4-9231-1	1480	1.790	34	2.562	2.750	5.125
3-4-9241-1X	1480	1.790	34	2.562	2.750	5.125
3-4-9241-2X	1480	1.790	34	2.562	2.750	5.125
3-4-9271-1	1480	1.750	10	2.500	1.953	4.000
350-4-111-1X	SPL350	2.374	46	3.500	2.401	6.220
350-4-121-1	SPL350	2.750	10	3.375	2.929	7.087
350-4-131-1	SPL350	2.750	10	3.752	2.992	6.614
350-4-141-1X	SPL350	2.750	10	3.752	2.992	6.614
350-4-151-1	SPL350	2.795	55	4.724	2.055	5.688
350-4-161-1X	SPL350	2.795	55	4.724	2.055	5.688
350-4-171-1	SPL350	3.046	48	4.251	1.957	5.256
350-4-201-1X	SPL350	2.544	49	3.896	2.677	6.200
350-4-31-1X	SPL350	2.544	49	3.820	2.677	6.200
350-4-61-1X	SPL350	2.390	46	3.252	2.322	5.551
350-4-71-1X	SPL350	2.390	46	3.252	2.322	5.551
350-4-91-1X	SPL350	2.374	46	3.751	2.401	5.642
4-4-1941	1550	1.875	10	2.750	2.375	4.406
4-4-2041-1	1550	1.750	10	2.375	2.188	4.000
4-4-2091-1	1550	1.750	10	2.625	2.250	4.281
4-4-3501-1	1550	2.250	10	3.500	3.000	5.125
4-4-3581-1X	1550	1.750	10	2.625	2.234	4.672
4-4-3851-1	1550	1.790	34	2.562	2.790	5.125
4-4-3861-1X	1550	1.790	34	2.562	2.790	5.125
4-4-4071-1X	1550	1.962	10	2.625	2.266	4.266
4-4-4101-1	1550	1.774	34	2.500	2.260	4.700
4-4-4101-2	1550	1.774	34	2.500	2.260	4.700
4-4-4111-1X	1550	1.774	34	2.500	2.260	4.700
4-4-4491-1	1550	1.998	38	2.750	2.125	4.035
4-4-4611	1550	1.998	38	2.750	1.984	4.156
4-4-4611-1	1550	1.998	38	2.750	1.984	4.156
4-4-4611-2	1550	1.998	38	2.750	1.984	4.156
4-4-4771-2	1550	1.962	10	2.750	2.812	5.000
4-4-4781-1	1550	1.750	10	2.500	1.938	4.125

Part Number	Series	Splines Data		Ground Hub Dia.	Length Thru Hole	*C/L to End of Hub
		O.D.	No. Teeth			
4-4-4781-2	1550	1.750	10	2.500	1.938	4.125
4-4-4791-1	1550	1.790	34	2.562	2.750	5.156
4-4-4801-1X	1550	1.790	34	2.562	2.750	5.156
4-4-5251-1	1550	1.750	10	2.500	2.260	4.290
4-4-5261-1	1550	2.024	39	3.000	2.312	5.000
4-4-5551-1	1550	1.790	34	2.625	2.185	4.275
4-4-5581-1	1550	2.143	41	2.938	2.500	4.500
4-4-5611-1X	1550	1.790	34	2.625	2.185	4.275
4-4-5621-1	1550	2.024	39	2.625	2.255	4.281
4-4-5691-1X	1550	2.024	39	2.625	2.255	4.281
4-4-5701-1X	1550	2.143	41	2.938	2.500	4.500
4-4-6101-1	1550	1.998	38	2.750	2.125	7.031
4-4-6471-1	1550	2.024	39	2.625	2.250	4.266
4-4-6731-1X	1550	2.024	39	3.000	2.312	5.000
4-4-6781-2	1550	1.962	10	2.750	2.812	5.000
4-4-6791-2	1550	1.750	10	2.500	1.915	4.115
4-4-6851-1X	1550	1.609	37	2.500	2.016	4.406
4-4-6951-1	1550	1.790	34	2.375	2.200	4.000
4-4-6961-1X	1550	1.790	34	2.375	2.200	4.000
4-4-6971-1	1550	1.998	38	3.000	2.125	4.500
4-4-6981-1X	1550	1.998	38	3.000	2.125	4.500
4-4-6991-1	1550	2.114	32	3.000	2.250	4.312
4-4-7001-1X	1550	2.114	32	3.000	2.250	4.312
4-4-7011-1	1550	2.364	36	3.000	2.688	5.078
4-4-7111-1X	1550	2.364	36	3.000	2.688	5.078
4-4-7341-1	1550	1.998	38	2.750	2.125	4.035
4-4-7551-1X	1550	2.024	39	2.625	2.250	4.266
4-4-7561-1	1550	2.024	39	3.000	2.297	4.281
4-4-7571-1X	1550	2.024	39	3.000	2.297	4.281
5-4-1051	1610	1.750	10	2.500	2.250	4.250
5-4-1391	1610	2.000	10	2.938	3.000	5.625
5-4-1481	1610	1.750	10	2.375	2.188	4.188
5-4-1481-1	1610	1.750	10	2.375	2.188	4.688
5-4-1521	1610	2.000	10	2.938	3.000	5.000
5-4-1661	1610	2.000	10	2.750	3.000	5.188
5-4-1661-1	1610	2.000	10	2.750	3.000	5.469
5-4-1891	1610	2.260	06	3.250	2.250	4.938
5-4-1891-1	1610	2.260	06	3.250	2.250	4.938
5-4-2031X	1610	1.960	06	2.750	3.000	5.000
5-4-2081	1610	1.750	10	2.625	2.250	4.750
5-4-2341	1650	2.359	18	3.000	2.781	5.219
5-4-2401	1610	1.625	10	2.375	2.125	4.125
5-4-2501	1610	1.875	10	2.750	2.375	5.000
5-4-2531	1610	1.962	10	3.000	2.250	4.750
5-4-3621	1610	1.750	10	2.750	2.250	5.000
5-4-4161X	1650	1.750	10	2.625	2.250	4.375
5-4-4391	1610	1.939	30	3.000	2.250	4.750
5-4-4401	1610	2.032	10	2.750	2.000	4.500
5-4-4441X	1610	1.750	10	2.750	2.250	6.000
5-4-4461	1610	1.750	10	2.625	2.250	5.344
5-4-4461-1	1610	1.750	10	2.625	2.250	5.344
5-4-4471-1	1610	1.962	10	2.625	2.250	5.312
5-4-4481	1610	1.750	10	2.750	2.250	5.406
5-4-4541	1610	1.962	10	3.000	2.250	5.375
5-4-4551	1610	1.962	10	2.500	2.000	5.219

Part Number	Series	Splines Data		Ground Hub Dia.	Length Thru Hole	*C/L to End of Hub
		O.D.	No. Teeth			
5-4-4741	1610	2.225	06	3.000	3.250	5.719
5-4-4751X	1610	2.225	06	3.000	3.250	5.719
5-4-4761X	1610	1.750	10	2.625	2.250	6.000
5-4-4771X	1610	1.962	10	2.625	2.250	6.000
5-4-4831	1610	1.790	34	2.562	2.750	5.312
5-4-4831-1	1610	1.790	34	2.562	2.750	5.312
5-4-4841-1X	1610	1.790	34	2.562	2.750	5.312
5-4-4841X	1610	1.790	34	2.562	2.750	5.312
5-4-4861	1610	2.390	46	3.500	3.391	6.125
5-4-4861-1	1610	2.390	46	3.500	3.391	6.125
5-4-4901X	1610	1.774	34	2.500	2.250	6.062
5-4-4961	1610	2.250	10	3.500	3.000	5.750
5-4-4961-1	1610	2.250	10	3.500	3.000	5.750
5-4-4971	1610	2.500	10	3.750	3.000	6.125
5-4-5081X	1610	1.774	34	2.500	2.250	5.438
5-4-5111-1X	1610	1.750	10	2.625	2.250	4.750
5-4-5111X	1610	1.750	10	2.625	2.250	4.750
5-4-5121-1X	1610	1.962	10	2.625	2.250	4.719
5-4-5121X	1610	1.962	10	2.625	2.250	4.719
5-4-5131X	1610	2.000	10	2.938	2.562	5.188
5-4-5161-1X	1610	2.149	16	2.938	3.000	6.250
5-4-5161X	1610	2.149	16	2.938	3.000	6.250
5-4-5231X	1610	1.790	34	2.567	2.830	5.310
5-4-5281X	1610	1.960	10	2.750	2.625	5.125
5-4-5321X	1610	1.962	10	2.750	2.625	5.938
5-4-5421	1610	2.024	39	2.750	2.453	5.125
5-4-5441	1610	2.024	39	2.750	2.438	5.938
5-4-5491-1X	1610	2.422	18	3.375	3.000	6.125
5-4-5511X	1610	2.149	16	2.938	3.000	6.500
5-4-5571-1	1610	1.774	34	2.500	2.250	4.875
5-4-5621-1X	1610	1.774	34	2.500	2.250	4.875
5-4-5631	1610	2.364	36	3.000	2.688	5.156
5-4-5721	1610	1.989	30	3.000	2.688	6.000
5-4-5731	1610	2.114	32	3.000	2.250	6.000
5-4-5751	1610	2.114	32	3.000	2.250	5.375
5-4-5861X	1610	1.998	38	3.000	2.125	4.844
5-4-5881	1610	2.024	39	2.750	2.000	4.500
5-4-5971X	1610	2.024	39	2.625	2.250	6.000
5-4-5991X	1610	2.024	39	2.625	2.250	5.312
5-4-6241	1610	2.024	39	3.000	2.312	6.219
5-4-6241-1	1610	2.024	39	3.000	2.312	6.219
5-4-6251	1610	1.774	34	2.500	2.250	6.062
5-4-6261	1610	1.774	34	2.500	2.250	5.438
5-4-6261-1	1610	1.774	34	2.500	2.250	5.438
5-4-6271	1610	2.024	39	3.000	2.312	5.531
5-4-6281X	1610	2.024	39	3.000	2.312	5.531
5-4-6291-1X	1610	2.024	39	3.000	2.312	6.219
5-4-6291X	1610	2.024	39	3.000	2.312	6.219
5-4-6321	1610	1.998	38	2.750	2.125	4.125
5-4-6321-1	1610	1.998	38	2.750	2.125	4.000
5-4-6341	1610	1.790	34	2.625	2.438	4.938
5-4-6351	1610	1.790	34	2.625	2.438	6.188
5-4-6361-1X	1610	1.962	10	2.625	2.250	5.312
5-4-6381-1X	1610	2.274	44	2.938	2.500	5.000
5-4-6381X	1610	2.274	44	2.938	2.500	5.000

Part Number	Series	Spline Data		Ground Hub Dia.	Length Thru Hole	*C/L to End of Hub	Part Number	Series	Spline Data		Ground Hub Dia.	Length Thru Hole	*C/L to End of Hub
		O.D.	No. Teeth						O.D.	No. Teeth			
5-4-6421	1610	2.024	39	3.000	2.312	4.875	5-4-8211-1X	1610	2.260	06	3.250	2.250	4.938
5-4-6421-1	1610	2.024	39	3.000	2.312	4.875	5-4-8261	1610	2.024	39	3.000	2.281	6.000
5-4-6431-1X	1610	2.024	39	3.000	2.312	4.875	5-4-8261-1	1610	2.024	39	3.000	2.281	6.000
5-4-6431X	1610	2.024	39	3.000	2.312	4.875	5-4-8301	1610	2.024	39	2.625	2.500	6.000
5-4-6441-1X	1610	2.024	39	3.000	2.312	4.875	5-4-8311-1	1610	2.274	44	3.000	2.500	5.000
5-4-6481	1610	1.998	38	2.750	1.969	4.156	5-4-8321-1	1610	2.274	44	2.938	2.500	5.000
5-4-6481-1	1610	1.998	38	2.750	1.969	4.156	5-4-8361-1	1610	1.962	10	2.750	2.812	5.281
5-4-6531-1	1610	2.635	20	3.750	2.750	5.062	5-4-8411-1X	1610	2.024	39	2.625	2.250	5.312
5-4-6891X	1610	2.250	10	3.000	3.000	5.625	5-4-8411X	1610	2.024	39	2.625	2.250	5.312
5-4-6951X	1610	2.024	39	2.750	2.453	5.125	5-4-8421X	1610	2.024	39	2.625	2.250	6.000
5-4-6961X	1610	2.024	39	2.750	2.438	5.938	5-4-8431-1X	1610	2.274	44	2.938	2.500	5.000
5-4-7041-1	1610	1.962	10	2.750	2.812	5.281	5-4-8441X	1610	1.790	34	2.625	2.438	6.188
5-4-7121X	1610	1.998	38	3.000	2.125	4.844	5-4-8491-1	1610	1.790	34	2.625	2.422	4.938
5-4-7181X	1610	2.114	32	3.000	2.250	6.000	5-4-8501-1X	1610	1.790	34	2.625	2.422	4.938
5-4-7191	1610	2.364	36	3.000	2.688	5.156	5-4-8561-1	1610	1.790	34	2.375	2.203	4.125
5-4-7201X	1610	2.364	36	3.000	2.688	5.156	5-4-8571-1X	1610	1.790	34	2.375	2.203	4.125
5-4-7211X	1610	2.364	36	3.000	2.688	5.156	5-4-8581-1	1610	1.998	38	3.000	2.125	4.844
5-4-7221X	1610	2.114	32	3.000	2.250	5.375	5-4-8591-1X	1610	1.998	38	3.000	2.125	4.844
5-4-7231X	1610	2.364	36	3.000	2.703	6.000	5-4-8601-1	1610	2.114	32	3.000	2.234	5.375
5-4-7251X	1610	1.989	30	3.000	2.688	6.000	5-4-8611-1X	1610	2.114	32	3.000	2.234	5.375
5-4-7261	1610	1.790	34	2.625	2.188	4.750	5-4-8621-1	1610	2.364	36	3.000	2.688	5.156
5-4-7261-1	1610	1.790	34	2.625	2.188	4.750	5-4-8631-1X	1610	2.364	36	3.000	2.688	5.156
5-4-7271-1	1610	2.143	41	2.938	2.500	5.250	5-4-8641-1	1610	2.364	36	3.000	2.688	5.156
5-4-7301-1X	1610	1.790	34	2.625	2.188	4.750	5-4-8651-1X	1610	2.364	36	3.000	2.688	5.156
5-4-7311-1X	1610	2.143	41	2.938	2.500	5.250	5-4-8661-1	1610	1.989	30	3.000	2.688	6.000
5-4-7331-1	1610	2.390	46	3.250	2.312	4.938	5-4-8671-1X	1610	1.989	30	3.000	2.688	6.000
5-4-7341-1X	1610	2.390	46	3.250	2.312	4.938	5-4-8681-1	1610	2.114	32	3.000	2.234	6.000
5-4-7351-1	1610	2.374	46	3.250	2.891	4.547	5-4-8691-1X	1610	2.114	32	3.000	2.234	6.000
5-4-7361-1X	1610	2.374	46	3.250	2.891	4.547	5-4-8901-1X	1610	1.962	10	2.625	2.250	5.312
5-4-7381-1	1610	2.250	10	3.750	3.000	5.750	5-4-8911-1	1610	1.790	34	2.500	2.250	5.438
5-4-7391-1X	1610	2.250	10	3.750	3.000	5.750	5-4-8971-1	1610	1.998	38	2.750	2.125	4.000
5-4-7551-1	1610	2.143	41	2.938	3.000	6.500	5-4-9101-1X	1610	2.274	44	2.938	2.328	4.844
5-4-7561	1610	2.143	41	2.938	2.500	6.000	5-4-9111-1X	1610	2.143	41	2.938	2.500	5.250
5-4-7561-1	1610	2.143	41	2.938	2.500	6.000	5-4-9121-1X	1610	2.143	41	2.938	2.500	6.000
5-4-7571-1X	1610	2.143	41	2.938	2.500	6.000	5-4-9121X	1610	2.143	41	2.938	2.500	6.000
5-4-7571X	1610	2.143	41	2.938	2.500	6.000	5-4-9131-1X	1610	2.143	41	2.938	3.000	6.500
5-4-7581-1	1610	1.750	10	2.500	2.250	4.720	5-4-9141	1610	2.178	43	3.531	2.031	5.406
5-4-7601-1	1610	1.998	38	2.750	2.125	7.562	5-4-9141-1	1610	2.178	43	3.531	2.031	5.406
5-4-7631-1	1610	1.750	10	2.500	1.953	4.125	5-4-9221-1	1610	2.024	39	3.000	2.281	4.875
5-4-7641-1	1610	2.343	45	3.750	3.000	5.750	5-4-9231-1X	1610	2.024	39	3.000	2.281	4.875
5-4-7651-1X	1610	2.343	45	3.750	3.000	5.750	5-4-9241-1X	1610	2.024	39	3.000	2.281	6.000
5-4-7781-1	1610	1.790	34	2.562	2.750	5.312	5-4-9241X	1610	2.024	39	3.000	2.281	6.000
5-4-781	1610	1.750	10	2.625	2.250	4.125	5-4-9261-1X	1610	2.274	44	3.000	2.500	5.000
5-4-7951-1	1610	2.547	49	4.000	2.750	5.500	5-4-9271X	1610	2.024	39	2.625	2.500	6.000
5-4-7971	1610	2.024	39	2.625	2.250	5.312	5-4-9291-1	1610	2.024	39	3.000	2.250	6.000
5-4-7971-1	1610	2.024	39	2.625	2.250	5.312	5-4-9311-1X	1610	2.024	39	3.000	2.250	6.000
5-4-7981	1610	2.024	39	2.625	2.234	4.719	5-4-9351-1	1610	2.024	39	3.000	2.500	5.594
5-4-7981-1	1610	2.024	39	2.625	2.234	4.719	5001480	SPL55	1.790	34	2.564	2.760	4.870
5-4-7991	1610	2.024	39	2.625	2.250	6.000	5001766	SPL170	2.024	39	3.000	2.281	5.540
5-4-8001	1610	1.790	34	2.625	2.438	6.188	5001768	SPL170	2.024	39	2.625	2.500	5.750
5-4-8021-1	1610	2.274	44	2.938	2.328	4.844	5001782	SPL70	2.024	39	3.000	1.844	3.878
5-4-8031-1X	1610	2.274	44	2.938	2.328	4.844	5001789	SPL70	1.790	34	2.562	2.750	6.650
5-4-8061-1X	1610	1.790	34	2.562	2.750	5.312	5002873	1810	2.143	41	3.000	2.188	4.680
5-4-8131-1X	1610	2.024	39	2.625	2.234	4.719	5002874	SPL100	2.143	41	3.000	2.166	4.310
5-4-8131X	1610	2.024	39	2.625	2.234	4.719	5002875	SPL100	2.143	41	3.000	2.166	4.310

Part Number	Series	Splines Data		Ground Hub Dia.	Length Thru Hole	*C/L to End of Hub
		O.D.	No. Teeth			
5002876	1710	2.143	41	3.000	2.166	5.380
5002877	1710	2.143	41	3.000	2.166	5.380
5002878	SPL140	2.143	41	3.000	2.166	5.030
5002879	SPL140	2.143	41	3.000	2.166	5.030
5003328	SPL55	2.024	39	3.000	1.847	3.875
5003491	1410	1.276	29	1.875	1.495	3.188
5003553	1710	2.390	46	3.250	2.328	5.391
5003555	1760	2.390	46	3.250	2.328	5.062
5003556	1810	2.390	46	3.250	2.312	5.156
5003557	SPL140	2.390	46	3.250	2.323	5.660
5003558	SPL170	2.390	46	3.250	2.328	5.100
5003812	SPL55	2.034	39	3.000	1.844	5.438
5003813	SPL55	2.034	39	3.000	1.844	5.438
5004767	1760	2.390	46	3.250	2.328	5.062
5005379	SPL90	2.024	39	2.626	2.245	4.160
5006607	SPL100	2.024	39	3.000	1.817	4.150
5006608	SPL100	2.024	39	3.000	1.817	4.150
5006976	1480	2.024	39	3.000	1.832	3.878
5006977	SPL70	2.024	39	3.000	1.844	3.878
5007493	SPL140	2.024	39	3.000	1.817	4.470
5007494	SPL140	2.024	39	3.000	1.817	4.470
5008454	1760	2.544	49	3.818	2.125	5.200
5008577	SPL170	2.024	39	3.000	2.281	5.540
5008578	SPL170	2.024	39	2.625	2.500	5.750
5009705	SPL170	1.774	34	2.500	2.250	6.440
55-4-03328-1X	SPL55	2.024	39	3.000	1.847	3.875
55-4-03813-1X	SPL55	2.034	39	3.000	1.844	5.438
55-4-101-1X	SPL55	1.790	34	2.564	2.760	4.870
55-4-111-1	SPL55	1.750	10	2.500	1.935	5.102
55-4-31-1	SPL55	1.790	34	2.375	2.188	4.219
55-4-41-1X	SPL55	1.790	34	2.375	2.188	4.219
55-4-71-1	SPL55	2.024	39	3.000	2.281	4.330
55-4-81-1X	SPL55	2.024	39	3.000	2.281	4.330
55-4-91-1	SPL55	1.790	34	2.564	2.760	4.870
6.3-4-03555-1X	1760	2.390	46	3.250	2.328	5.062
6.3-4-05582-1	1760	2.544	49	3.819	2.677	5.750
6.3-4-08441-1X	1760	2.544	49	3.819	2.677	5.750
6.3-4-08454X	1760	2.544	49	3.818	2.125	5.200
6.3-4-08455-1X	1760	2.544	49	3.818	2.125	5.200
6.3-4-101	1760	2.374	46	3.250	2.625	5.438
6.3-4-101-1	1760	2.374	46	3.250	2.625	5.438
6.3-4-1021X	1760	2.364	36	3.000	2.688	5.438
6.3-4-1031	1760	2.390	46	3.250	2.328	5.062
6.3-4-1031-1	1760	2.390	46	3.250	2.328	5.062
6.3-4-1041-1X	1760	2.390	46	3.250	2.328	5.062
6.3-4-1041X	1760	2.390	46	3.250	2.328	5.062
6.3-4-1051-1	1760	2.794	54	3.750	3.000	5.970
6.3-4-1061	1760	2.143	41	2.938	2.500	5.250
6.3-4-1061-1	1760	2.143	41	2.938	2.500	5.250
6.3-4-1071-1X	1760	2.143	41	2.938	2.500	5.250
6.3-4-1071X	1760	2.143	41	2.938	2.500	5.250
6.3-4-1091-1	1760	2.250	10	3.750	3.000	5.625
6.3-4-1101-1X	1760	2.250	10	3.750	3.000	5.625
6.3-4-1141-1X	1760	2.024	39	3.000	2.312	5.188
6.3-4-1151	1760	2.390	46	3.375	3.188	6.000

Part Number	Series	Splines Data		Ground Hub Dia.	Length Thru Hole	*C/L to End of Hub
		O.D.	No. Teeth			
6.3-4-1151-1	1760	2.390	46	3.375	3.188	6.000
6.3-4-1161-1X	1760	2.390	46	3.375	3.188	6.000
6.3-4-1161X	1760	2.390	46	3.375	3.188	6.000
6.3-4-1171	1760	2.143	41	2.938	3.000	5.812
6.3-4-1201-1	1760	2.750	10		3.000	5.969
6.3-4-1251	1760	2.544	49	4.000	2.750	5.562
6.3-4-1251-1	1760	2.544	49	4.000	2.750	5.562
6.3-4-1261X	1760	2.032	10	2.750	2.000	5.000
6.3-4-1271-1X	1760	2.374	46	3.750	2.422	5.406
6.3-4-1281-1X	1760	2.374	46	3.750	2.422	5.406
6.3-4-1281X	1760	2.374	46	3.750	2.422	5.406
6.3-4-1321	1760	2.274	44	2.938	2.328	5.094
6.3-4-1321-1	1760	2.274	44	2.938	2.328	5.094
6.3-4-1331-1X	1760	2.274	44	2.938	2.328	5.094
6.3-4-1331X	1760	2.274	44	2.938	2.328	5.094
6.3-4-1341-1X	1760	2.024	39	3.000	2.312	5.188
6.3-4-1391-1X	1760	2.374	46	3.500	2.406	5.375
6.3-4-1391X	1760	2.374	46	3.500	2.406	5.375
6.3-4-1401-1X	1760	2.500	10	3.500	2.406	5.406
6.3-4-1401X	1760	2.500	10	3.500	2.406	5.406
6.3-4-141	1760	2.149	16	2.938	3.000	5.812
6.3-4-141-1	1760	2.149	16	2.938	3.000	5.812
6.3-4-1411	1760	2.274	44	3.000	2.500	5.250
6.3-4-1411-1	1760	2.274	44	3.000	2.500	5.250
6.3-4-1421	1760	2.274	44	2.938	2.500	5.250
6.3-4-1421-1	1760	2.274	44	2.938	2.500	5.250
6.3-4-1481-1X	1760	2.274	44	2.938	2.500	5.250
6.3-4-1481X	1760	2.274	44	2.938	2.500	5.250
6.3-4-1491-1	1760	1.998	38	3.000	2.125	4.844
6.3-4-1501-1X	1760	1.998	38	3.000	2.125	4.844
6.3-4-151	1760	2.500	10	3.500	2.406	5.406
6.3-4-151-1	1760	2.500	10	3.500	2.406	5.406
6.3-4-1511-1	1760	2.114	32	3.000	2.250	5.000
6.3-4-1521-1X	1760	2.114	32	3.000	2.250	5.000
6.3-4-1531-1	1760	2.364	36	3.000	2.688	5.438
6.3-4-1541-1X	1760	2.364	36	3.000	2.688	5.438
6.3-4-1551-1	1760	2.364	36	3.000	2.688	5.438
6.3-4-1561-1X	1760	2.364	36	3.000	2.688	5.438
6.3-4-1591-1	1760	2.178	43	3.539	2.050	5.500
6.3-4-1601-1	1760	2.364	36	3.500	2.485	5.230
6.3-4-1611-1X	1760	2.364	36	3.500	2.485	5.230
6.3-4-1621-1X	1760	2.274	44	2.938	2.328	5.094
6.3-4-1621X	1760	2.274	44	2.938	2.328	5.094
6.3-4-1631-1X	1760	2.143	41	2.938	2.500	5.250
6.3-4-1641X	1760	2.143	41	2.938	3.000	5.812
6.3-4-1651-1X	1760	2.390	46	3.375	3.188	6.000
6.3-4-1651X	1760	2.390	46	3.375	3.188	6.000
6.3-4-1681	1760	2.794	54		2.750	5.625
6.3-4-1681-1	1760	2.794	54		2.750	5.625
6.3-4-1701-1	1760	2.024	39	3.000	2.250	5.625
6.3-4-171-1X	1760	2.225	06	3.000	3.250	6.000
6.3-4-171X	1760	2.225	06	3.000	3.250	6.000
6.3-4-1711-1X	1760	2.024	39	3.000	2.250	5.625
6.3-4-1761-1	1760	2.795	55	4.725	2.047	5.000
6.3-4-181X	1760	2.000	10	2.938	2.562	5.375

Part Number	Series	Spline Data		Ground Hub Dia.	Length Thru Hole	*C/L to End of Hub
		O.D.	No. Teeth			
6.3-4-1861-1	1760	2.544	49	3.818	2.125	5.200
6.3-4-1891-1X	1760	2.753	43	3.750	1.790	4.870
6.3-4-1891X	1760	2.753	43	3.750	1.790	4.870
6.3-4-191X	1760	2.024	39	3.000	2.438	5.188
6.3-4-211-1X	1760	2.374	46	3.250	2.625	5.438
6.3-4-211X	1760	2.374	46	3.250	2.625	5.438
6.3-4-221X	1760	1.964	10	2.625	2.250	5.625
6.3-4-231X	1760	2.149	16	2.938	2.500	5.250
6.3-4-241-1X	1760	2.422	18	3.375	3.000	6.000
6.3-4-241X	1760	2.422	18	3.375	3.000	6.000
6.3-4-251-1X	1760	2.149	16	2.938	3.000	5.812
6.3-4-251X	1760	2.149	16	2.938	3.000	5.812
6.3-4-271	1760	2.364	18	3.500	3.375	6.125
6.3-4-271-1	1760	2.364	18	3.500	3.375	6.125
6.3-4-291	1760	2.374	46	3.250	2.875	5.625
6.3-4-291-1	1760	2.374	46	3.250	2.875	5.625
6.3-4-301-1X	1760	2.374	46	3.250	2.875	5.625
6.3-4-301X	1760	2.374	46	3.250	2.875	5.625
6.3-4-331-1X	1760	2.274	44	2.938	2.500	5.250
6.3-4-331X	1760	2.274	44	2.938	2.500	5.250
6.3-4-381	1760	2.390	46	3.500	3.375	6.000
6.3-4-381-1	1760	2.390	46	3.500	3.375	6.000
6.3-4-391	1760	2.374	46	3.500	2.406	5.375
6.3-4-391-1	1760	2.374	46	3.500	2.406	5.375
6.3-4-41	1760	2.635	20	3.750	2.750	5.562
6.3-4-41-1	1760	2.635	20	3.750	2.750	5.562
6.3-4-421	1760	2.032	10	2.750	2.000	5.000
6.3-4-431	1760	1.939	30	3.000	2.250	5.250
6.3-4-51	1760	2.225	06	3.000	3.250	6.000
6.3-4-51-1	1760	2.225	06	3.000	3.250	6.000
6.3-4-5221-1X	1760	2.274	44	3.000	2.500	5.250
6.3-4-5221X	1760	2.274	44	3.000	2.500	5.250
6.3-4-531	1760	2.024	39	3.000	2.312	5.188
6.3-4-531-1	1760	2.024	39	3.000	2.312	5.188
6.3-4-541-1X	1760	2.024	39	3.000	2.312	5.188
6.3-4-541X	1760	2.024	39	3.000	2.312	5.188
6.3-4-61	1760	2.750	10	4.000	2.938	6.000
6.3-4-61-1	1760	2.750	10	4.000	2.938	6.000
6.3-4-641	1760	2.374	46	3.750	2.422	5.406
6.3-4-641-1	1760	2.374	46	3.750	2.422	5.406
6.3-4-651	1760	2.500	10	3.750	3.000	6.000
6.3-4-651-1	1760	2.500	10	3.750	3.000	6.031
6.3-4-661	1760	2.750	10	3.750	3.000	5.969
6.3-4-661-1	1760	2.750	10	3.750	3.000	5.969
6.3-4-701-1	1760	2.250	10	3.500	3.000	5.656
6.3-4-711	1760	2.750	10	3.750	3.000	5.969
6.3-4-711-1	1760	2.750	10	3.750	3.000	5.969
6.3-4-721-1X	1760	2.750	10	3.750	3.000	5.969
6.3-4-721X	1760	2.750	10	3.750	3.000	5.969
6.3-4-731-1X	1760	2.250	10	3.000	3.000	5.844
6.3-4-731X	1760	2.250	10	3.000	3.000	5.844
6.3-4-761-1X	1760	2.250	10	3.500	3.000	5.656
6.3-4-771-1X	1760	2.544	49	3.750	3.000	6.031
6.3-4-771X	1760	2.544	49	3.750	3.000	6.031
6.3-4-781-1X	1760	2.500	10	3.750	3.000	6.031

Part Number	Series	Spline Data		Ground Hub Dia.	Length Thru Hole	*C/L to End of Hub
		O.D.	No. Teeth			
6.3-4-781X	1760	2.500	10	3.750	3.000	6.000
6.3-4-791-1X	1760	2.750	10	3.750	3.000	5.969
6.3-4-791X	1760	2.750	10	3.750	3.000	5.969
6.3-4-811	1760	2.544	49	3.750	3.000	6.031
6.3-4-811-1	1760	2.544	49	3.750	3.000	6.031
6.3-4-841-1	1760	2.343	45	3.750	3.000	5.656
6.3-4-851X	1760	2.364	36	3.000	2.688	5.438
6.3-4-861-1X	1760	2.374	46	3.250	2.875	5.625
6.3-4-861X	1760	2.374	46	3.250	2.875	5.625
6.3-4-871-1X	1760	2.635	20	3.750	2.750	5.562
6.3-4-871X	1760	2.635	20	3.750	2.750	5.562
6.3-4-901-1X	1760	2.343	45	3.750	3.000	5.656
6.5-4-03556-1X	1810	2.390	46	3.250	2.312	5.156
6.5-4-08442X	1810	2.544	49	3.819	2.677	5.740
6.5-4-08443-1X	1810	2.544	49	3.820	2.692	5.740
6.5-4-08456X	1810	2.544	49	3.818	2.141	5.740
6.5-4-08457-1X	1810	2.544	49	3.818	2.141	5.740
6.5-4-1901	1810	2.750	10	3.500	3.000	6.062
6.5-4-1901-1	1810	2.750	10	3.500	3.000	6.062
6.5-4-1911	1810	2.250	10	3.000	3.000	5.844
6.5-4-1971	1810	2.225	06	3.000	3.250	6.000
6.5-4-1971-1	1810	2.225	06	3.000	3.250	6.000
6.5-4-1991	1810	2.422	18	3.375	3.000	5.812
6.5-4-1991-1	1810	2.422	18	3.375	3.000	5.812
6.5-4-2011	1810	2.635	20	3.750	2.750	5.562
6.5-4-2021	1810	2.250	10	3.500	3.000	5.844
6.5-4-2051	1810	1.939	30	3.000	2.250	5.375
6.5-4-2101	1810	2.500	10	3.500	2.406	5.406
6.5-4-2101-1	1810	2.500	10	3.500	2.406	5.406
6.5-4-2141	1810	2.250	10	3.125	2.250	5.375
6.5-4-2141-1	1810	2.250	10	3.125	2.250	5.375
6.5-4-2171	1810	2.750	10	4.000	2.938	6.000
6.5-4-2171-1	1810	2.750	10	4.000	2.938	6.000
6.5-4-2181	1810	2.631	25	3.625	3.000	5.781
6.5-4-2261	1810	2.031	10	2.750	2.000	5.250
6.5-4-2271X	1810	2.225	06	3.000	3.250	6.000
6.5-4-2291	1810	2.149	16	2.938	3.000	5.812
6.5-4-2291-1	1810	2.149	16	2.938	3.000	5.812
6.5-4-2341X	1810	2.000	10	2.938	2.562	5.375
6.5-4-2351X	1810	1.964	10	2.625	2.250	5.625
6.5-4-2361-1X	1810	2.422	18	3.375	3.000	5.812
6.5-4-2361X	1810	2.422	18	3.375	3.000	5.812
6.5-4-2401-1X	1810	2.149	16	2.938	3.000	5.812
6.5-4-2401X	1810	2.149	16	2.938	3.000	5.812
6.5-4-2471	1810	2.024	39	3.000	2.438	5.188
6.5-4-2491X	1810	2.024	39	3.000	2.438	5.188
6.5-4-2541	1810	2.390	46	3.500	3.375	6.156
6.5-4-2541-1	1810	2.390	46	3.500	3.375	6.156
6.5-4-2551X	1810	2.250	10	3.000	3.000	5.844
6.5-4-2581	1810	2.364	18	3.500	3.375	6.125
6.5-4-2581-1	1810	2.364	18	3.500	3.375	6.125
6.5-4-2701	1810	2.374	46	3.250	2.625	5.438
6.5-4-2701-1	1810	2.374	46	3.250	2.625	5.438
6.5-4-2711-1X	1810	2.374	46	3.250	2.625	5.438
6.5-4-2711X	1810	2.374	46	3.250	2.625	5.438

Part Number	Series	Splines Data		Ground Hub Dia.	Length Thru Hole	*C/L to End of Hub
		O.D.	No. Teeth			
6.5-4-2781	1810	2.024	39	2.750	2.438	5.531
6.5-4-2781-1	1810	2.024	39	2.750	2.438	5.625
6.5-4-2831X	1810	2.225	06	3.000	3.250	6.000
6.5-4-2911	1810	2.005	15	2.875	2.500	5.250
6.5-4-2931X	1810	2.750	10	3.500	3.000	6.062
6.5-4-3011	1810	2.350	16	3.750	2.750	5.562
6.5-4-3021	1810	2.635	20	3.750	2.750	5.562
6.5-4-3021-1	1810	2.635	20	3.750	2.750	5.562
6.5-4-3161	1810	2.364	36	3.000	2.688	5.438
6.5-4-3201	1810	2.374	46	3.250	2.875	5.688
6.5-4-3201-1	1810	2.374	46	3.250	2.875	5.688
6.5-4-3221-1X	1810	2.374	46	3.250	2.875	5.688
6.5-4-3221X	1810	2.374	46	3.250	2.875	5.688
6.5-4-3251	1810	2.374	46	3.500	2.406	5.406
6.5-4-3251-1	1810	2.374	46	3.500	2.406	5.406
6.5-4-3261	1810	2.024	39	2.750	2.000	5.188
6.5-4-3261-1	1810	2.024	39	2.750	2.000	5.188
6.5-4-3281-1X	1810	2.274	44	2.938	2.500	5.250
6.5-4-3281X	1810	2.274	44	2.938	2.500	5.250
6.5-4-3361	1810	2.560	20	3.500	3.344	6.125
6.5-4-3361-1	1810	2.560	20	3.500	3.344	6.125
6.5-4-3371	1810	2.024	39	3.000	2.312	5.190
6.5-4-3371-1	1810	2.024	39	3.000	2.312	5.190
6.5-4-3381-1X	1810	2.024	39	3.000	2.312	5.190
6.5-4-3381X	1810	2.024	39	3.000	2.312	5.190
6.5-4-3441	1810	2.374	46	3.750	2.406	5.219
6.5-4-3441-1	1810	2.374	46	3.750	2.406	5.219
6.5-4-3451	1810	2.500	10	3.750	3.000	5.875
6.5-4-3451-1	1810	2.500	10	3.750	3.000	5.875
6.5-4-3461	1810	2.750	10	3.750	3.000	6.062
6.5-4-3461-1	1810	2.750	10	3.750	3.000	6.062
6.5-4-3491	1810	2.750	10	3.750	3.000	6.062
6.5-4-3491-1	1810	2.750	10	3.750	3.000	6.062
6.5-4-3501-1X	1810	2.750	10	3.750	3.000	6.062
6.5-4-3501X	1810	2.750	10	3.750	3.000	6.062
6.5-4-3541-1X	1810	2.635	20	3.750	2.750	5.562
6.5-4-3541X	1810	2.635	20	3.750	2.750	5.562
6.5-4-3551-1X	1810	2.500	10	3.750	3.000	5.875
6.5-4-3551X	1810	2.500	10	3.750	3.000	5.875
6.5-4-3561-1X	1810	2.750	10	3.750	3.000	6.062
6.5-4-3561X	1810	2.750	10	3.750	3.000	6.062
6.5-4-3571-1X	1810	2.024	39	2.750	2.438	5.625
6.5-4-3571X	1810	2.024	39	2.750	2.438	5.531
6.5-4-3581-1X	1810	2.374	46	3.250	2.875	5.688
6.5-4-3581X	1810	2.374	46	3.250	2.875	5.688
6.5-4-3611	1810	2.544	49	3.750	3.000	5.875
6.5-4-3611-1	1810	2.544	49	3.750	3.000	5.875
6.5-4-3621-1X	1810	2.544	49	3.750	3.000	5.875
6.5-4-3621X	1810	2.544	49	3.750	3.000	5.875
6.5-4-3641X	1810	2.364	36	3.000	2.688	5.438
6.5-4-3651X	1810	2.364	36	3.000	2.688	5.438
6.5-4-3681	1810	2.143	41	2.938	2.500	5.250
6.5-4-3681-1	1810	2.143	41	2.938	2.500	5.250
6.5-4-3691-1X	1810	2.143	41	2.938	2.500	5.250
6.5-4-3691X	1810	2.143	41	2.938	2.500	5.250

Part Number	Series	Splines Data		Ground Hub Dia.	Length Thru Hole	*C/L to End of Hub
		O.D.	No. Teeth			
6.5-4-3721	1810	2.390	46	3.250	2.312	5.156
6.5-4-3721-1	1810	2.390	46	3.250	2.312	5.156
6.5-4-3731-1X	1810	2.390	46	3.250	2.312	5.156
6.5-4-3731X	1810	2.390	46	3.250	2.312	5.156
6.5-4-3801-1	1810	2.750	10	3.875	3.000	6.062
6.5-4-3821-1	1810	2.544	49	4.000	2.750	5.562
6.5-4-3851-1X	1810	2.024	39	3.000	2.320	5.188
6.5-4-3881-1X	1810	2.024	39	3.000	2.312	5.750
6.5-4-3911	1810	2.390	46	3.375	3.188	6.000
6.5-4-3911-1	1810	2.390	46	3.375	3.188	6.000
6.5-4-3921-1X	1810	2.390	46	3.375	3.188	6.000
6.5-4-3921X	1810	2.390	46	3.375	3.188	6.000
6.5-4-3931	1810	2.143	41	2.938	3.000	5.812
6.5-4-4001-1X	1810	2.374	46	3.750	2.406	5.219
6.5-4-4001X	1810	2.374	46	3.750	2.406	5.219
6.5-4-4011-1X	1810	2.374	46	3.750	2.406	5.219
6.5-4-4011X	1810	2.374	46	3.750	2.406	5.219
6.5-4-4081-1	1810	2.274	44	2.938	2.344	5.090
6.5-4-4091-1X	1810	2.274	44	2.938	2.344	5.090
6.5-4-4191-1X	1810	2.024	39	3.000	2.312	5.190
6.5-4-4211-1	1810	2.364	18	3.750	2.344	5.625
6.5-4-4221-1X	1810	2.250	10	3.125	2.250	5.375
6.5-4-4241-1X	1810	2.250	10	3.312	2.250	5.375
6.5-4-4261-1X	1810	2.500	10	3.500	2.406	5.406
6.5-4-4271-1X	1810	2.374	46	3.500	2.406	5.406
6.5-4-4271X	1810	2.374	46	3.500	2.406	5.406
6.5-4-4281-1X	1810	2.024	39	2.750	2.000	5.188
6.5-4-4281X	1810	2.024	39	2.750	2.000	5.188
6.5-4-4291-1X	1810	2.500	10	3.500	2.406	5.406
6.5-4-4291X	1810	2.500	10	3.500	2.406	5.406
6.5-4-4311	1810	2.274	44	3.000	2.500	5.250
6.5-4-4311-1	1810	2.274	44	3.000	2.500	5.250
6.5-4-4321	1810	2.274	44	2.938	2.500	5.250
6.5-4-4321-1	1810	2.274	44	2.938	2.500	5.250
6.5-4-4351-1X	1810	2.274	44	2.938	2.500	5.250
6.5-4-4351X	1810	2.274	44	2.938	2.500	5.250
6.5-4-4411-1	1810	2.364	36	3.000	2.688	5.438
6.5-4-4421-1X	1810	2.364	36	3.000	2.688	5.438
6.5-4-4431-1	1810	2.364	36	3.000	2.688	5.438
6.5-4-4441-1X	1810	2.364	36	3.000	2.688	5.438
6.5-4-4451-1	1810	2.114	32	3.000	2.250	5.000
6.5-4-4461-1X	1810	2.114	32	3.000	2.250	5.000
6.5-4-4471-1	1810	2.364	36	3.500	2.500	5.230
6.5-4-4481-1X	1810	2.364	36	3.500	2.500	5.230
6.5-4-4571-1X	1810	2.274	44	3.000	2.500	5.250
6.5-4-4571X	1810	2.274	44	3.000	2.500	5.250
6.5-4-4591-1X	1810	2.274	44	2.938	2.344	5.090
6.5-4-4601-1X	1810	2.143	41	2.938	2.500	5.250
6.5-4-4601X	1810	2.143	41	2.938	2.500	5.250
6.5-4-4611-1X	1810	2.390	46	3.375	3.188	6.000
6.5-4-4611X	1810	2.390	46	3.375	3.188	6.000
6.5-4-4621X	1810	2.143	41	2.938	3.000	5.812
6.5-4-4631	1810	2.794	54	2.750	2.750	5.625
6.5-4-4631-1	1810	2.794	54	2.750	2.750	5.625
6.5-4-4651-1	1810	2.024	39	3.000	2.250	5.000

Part Number	Series	Spline Data		Ground Hub Dia.	Length Thru Hole	*C/L to End of Hub
		O.D.	No. Teeth			
6.5-4-4661-1X	1810	2.024	39	3.000	2.250	5.000
6.5-4-5091	1810	2.544	49	3.818	2.141	5.740
6.5-4-5091-1	1810	2.544	49	3.818	2.141	5.740
6.5-4-5111X	1810	2.390	46	3.250	2.312	5.156
6.5-4-5131-1X	1810	2.750	43	3.750	1.792	5.406
6.5-4-5131X	1810	2.750	43	3.750	1.792	5.406
6-4-02877-1X	1710	2.143	41	3.000	2.166	5.380
6-4-03553-1X	1710	2.390	46	3.250	2.328	5.391
6-4-08438X	1710	2.544	49	3.819	2.677	6.050
6-4-08439-1X	1710	2.544	49	3.819	2.677	6.050
6-4-08446X	SPL250	2.544	49	3.819	2.672	6.200
6-4-08447-1X	1710	2.143	41	2.938	3.000	6.620
6-4-08449X	1710	2.544	49	3.819	2.125	6.260
6-4-08450-1X	1710	2.544	49	3.819	2.125	6.260
6-4-08452X	1710	2.544	49	3.819	2.125	5.570
6-4-08453-1X	1710	2.544	49	3.819	2.125	5.570
6-4-10291	1710	2.544	49	3.819	2.125	5.570
6-4-10291-1	1710	2.544	49	3.819	2.125	5.570
6-4-10301	1710	2.143	41	2.938	3.000	6.620
6-4-10301-1	1710	2.143	41	2.938	3.000	6.620
6-4-10311	1710	2.544	49	3.819	2.125	6.260
6-4-10311-1	1710	2.544	49	3.819	2.125	6.260
6-4-10321-1X	1710	2.024	39	3.000	2.281	5.250
6-4-10351-1X	1710	2.750	43	3.750	1.792	5.929
6-4-10351X	1710	2.750	43	3.750	1.792	5.929
6-4-10401-1X	1710	2.024	39	3.000	2.281	6.125
6-4-1971	1710	2.250	10	3.250	2.250	5.250
6-4-1991	1710	2.250	10	3.000	3.000	6.062
6-4-1991-1	1710	2.250	10	3.000	3.000	6.062
6-4-2001	1710	2.000	10	3.250	3.000	5.625
6-4-2061	1710	1.960	10	2.938	2.219	4.500
6-4-2141	1710	2.250	10	3.500	3.000	5.250
6-4-2181	1710	2.149	16	2.938	3.000	5.500
6-4-2191	1710	2.000	10	2.938	3.000	5.625
6-4-2211	1710	1.964	10	2.625	2.250	4.500
6-4-2381	1710	1.750	10	2.750	2.250	4.875
6-4-2441	1710	2.250	10	3.125	2.250	5.250
6-4-2511	1710	2.250	10	3.000	2.875	5.250
6-4-3001	1710	2.005	15	2.875	2.500	5.375
6-4-3021	1710	2.631	25	3.625	3.000	5.250
6-4-3031	1710	2.225	06	3.000	3.250	5.312
6-4-3031-1	1710	2.225	06	3.000	3.250	5.438
6-4-3041-1X	1710	2.225	06	3.000	3.250	5.438
6-4-3041X	1710	2.225	06	3.000	3.250	5.312
6-4-3141	1710	3.003	23	4.000	3.031	4.844
6-4-3161	1710	2.422	18	3.375	3.000	5.250
6-4-3221	1710	1.960	10	2.750	2.625	5.250
6-4-3221-1	1710	1.960	10	2.750	2.625	5.250
6-4-3241	1710	2.000	10	2.938	2.562	5.188
6-4-3291	1710	1.964	10	3.000	2.250	4.562
6-4-3501-1	1710	2.260	06	3.250	2.250	5.300
6-4-3791	1710	2.032	10	2.750	2.000	5.000
6-4-3831	1710	1.962	10	2.750	2.812	5.156
6-4-3831-1	1710	1.962	10	2.750	2.812	5.156
6-4-4091	1710	1.750	10	2.750	2.250	6.250

Part Number	Series	Spline Data		Ground Hub Dia.	Length Thru Hole	*C/L to End of Hub
		O.D.	No. Teeth			
6-4-4151	1710	1.962	10	2.625	2.250	6.125
6-4-4151-1	1710	1.962	10	2.625	2.250	6.125
6-4-4171-1X	1710	2.149	16	2.938	3.000	5.500
6-4-4171X	1710	2.149	16	2.938	3.000	5.500
6-4-4271	1710	1.775	16	2.375	2.000	4.750
6-4-4291X	1710	2.000	10	2.938	2.562	5.188
6-4-4301X	1710	1.750	10	2.625	2.250	5.250
6-4-4361X	1710	1.960	10	2.750	2.625	5.250
6-4-4371	1710	1.939	30	3.000	2.250	4.562
6-4-4391X	1710	2.000	10	2.750	2.562	5.188
6-4-4411-1X	1710	2.250	10	3.000	3.000	6.062
6-4-4411X	1710	2.250	10	3.000	3.000	6.062
6-4-4421	1710	2.500	10	3.500	2.406	5.156
6-4-4421-1	1710	2.500	10	3.500	2.406	5.156
6-4-4481X	1710	1.960	10	2.750	2.625	6.500
6-4-4531	1710	2.351	16	3.750	2.750	5.188
6-4-4551	1710	2.750	10	3.500	3.000	5.750
6-4-4551-1	1710	2.750	10	3.500	3.000	5.750
6-4-4561	1710	2.364	18	3.500	3.375	5.750
6-4-4561-1	1710	2.364	18	3.500	3.375	5.750
6-4-4581	1710	2.422	18	3.375	3.000	5.812
6-4-4581-1	1710	2.422	18	3.375	3.000	5.812
6-4-4591	1710	2.149	16	2.938	3.000	6.625
6-4-4601	1710	2.350	16	3.312	2.750	4.938
6-4-4651	1710	2.750	10	4.000	2.938	5.312
6-4-4651-1	1710	2.750	10	4.000	2.938	5.312
6-4-4721	1710	1.962	10	2.625	2.250	4.500
6-4-4731-1X	1710	1.962	10	2.625	2.250	4.500
6-4-4731X	1710	1.962	10	2.625	2.250	4.500
6-4-4741X	1710	2.000	10	2.938	2.562	5.188
6-4-4751-1X	1710	2.422	18	3.375	3.000	5.812
6-4-4751X	1710	2.422	18	3.375	3.000	5.812
6-4-4771	1710	2.390	46	3.500	3.375	5.750
6-4-4771-1	1710	2.390	46	3.500	3.375	5.750
6-4-4831X	1710	1.750	10	2.750	2.250	6.250
6-4-4851-1X	1710	1.962	10	2.625	2.250	6.125
6-4-4851X	1710	1.962	10	2.625	2.250	6.125
6-4-4861X	1710	1.750	10	2.625	2.250	6.125
6-4-4961	1710	2.149	16	2.938	2.500	5.188
6-4-5031-1	1710	1.790	34	2.562	2.750	5.594
6-4-5041-1X	1710	1.790	34	2.562	2.750	5.594
6-4-5041X	1710	1.790	34	2.562	2.750	7.188
6-4-5061X	1710	2.149	16	2.938	2.500	5.188
6-4-5101X	1710	2.024	39	3.000	2.438	5.188
6-4-5111X	1710	1.774	34	2.500	2.250	5.969
6-4-5131-1X	1710	1.774	34	2.500	2.250	4.875
6-4-5131X	1710	1.774	34	2.500	2.250	4.875
6-4-5141	1710	1.962	10	2.625	2.250	5.250
6-4-5151X	1710	1.962	10	2.625	2.250	5.250
6-4-5251X	1710	2.750	10	3.500	3.000	5.750
6-4-5341	1710	2.350	16	3.750	2.750	5.188
6-4-5351	1710	2.635	20	3.750	2.750	5.188
6-4-5351-1	1710	2.635	20	3.750	2.750	5.188
6-4-5451	1710	2.374	46	3.250	2.625	5.688
6-4-5451-1	1710	2.374	46	3.250	2.625	5.688

Part Number	Series	Splines Data		Ground Hub Dia.	Length Thru Hole	*C/L to End of Hub
		O.D.	No. Teeth			
6-4-5461-1X	1710	2.374	46	3.250	2.625	5.688
6-4-5461X	1710	2.374	46	3.250	2.625	5.688
6-4-5481X	1710	2.149	16	2.938	3.000	6.625
6-4-5501	1710	2.024	39	2.750	2.438	6.500
6-4-5501-1	1710	2.024	39	2.750	2.438	6.500
6-4-5521	1710	2.024	39	2.750	2.438	5.250
6-4-5521-1	1710	2.024	39	2.750	2.438	5.250
6-4-5581-1X	1710	1.750	10	2.625	2.250	4.500
6-4-5581X	1710	1.750	10	2.625	2.250	4.500
6-4-5711	1710	2.364	36	3.000	2.688	5.438
6-4-5791	1710	2.114	32	3.000	2.250	6.250
6-4-5801	1710	2.364	36	3.000	2.688	6.500
6-4-5811	1710	2.114	32	3.000	2.250	4.562
6-4-5841	1710	2.374	46	3.500	2.406	5.156
6-4-5841-1	1710	2.374	46	3.500	2.406	5.156
6-4-5851	1710	2.024	39	2.750	2.000	5.000
6-4-5851-1	1710	2.024	39	2.750	2.000	5.000
6-4-5931	1710	2.374	46	3.250	2.875	5.938
6-4-5931-1	1710	2.374	46	3.250	2.875	5.938
6-4-5961-1X	1710	2.374	46	3.250	2.875	5.938
6-4-5961X	1710	2.374	46	3.250	2.875	5.938
6-4-6001X	1710	2.024	39	2.625	2.250	5.250
6-4-6021-1X	1710	2.024	39	2.625	2.250	6.125
6-4-6021X	1710	2.024	39	2.625	2.250	6.125
6-4-6041-1X	1710	2.274	44	2.938	2.500	5.188
6-4-6041X	1710	2.274	44	2.938	2.500	5.188
6-4-6321	1710	1.774	34	2.500	2.250	5.969
6-4-6321-1	1710	1.774	34	2.500	2.250	5.969
6-4-6331	1710	1.774	34	2.500	2.250	4.875
6-4-6331-1	1710	1.774	34	2.500	2.250	4.875
6-4-6371	1710	2.024	39	3.000	2.312	6.250
6-4-6371-1	1710	2.024	39	3.000	2.312	6.250
6-4-6381X	1710	2.024	39	3.000	2.312	6.250
6-4-6391-1X	1710	2.024	39	3.000	2.312	6.250
6-4-6391X	1710	2.024	39	3.000	2.312	6.250
6-4-6401	1710	2.024	39	3.000	2.327	5.156
6-4-6401-1	1710	2.024	39	3.000	2.327	5.156
6-4-6411X	1710	2.024	39	3.000	2.327	5.156
6-4-6421-1X	1710	2.024	39	3.000	2.327	5.156
6-4-6421X	1710	2.024	39	3.000	2.327	5.156
6-4-6451	1710	1.790	34	2.625	2.438	6.312
6-4-6451-1	1710	1.790	34	2.625	2.438	6.312
6-4-6481	1710	1.790	34	2.625	2.438	5.438
6-4-6571	1710	2.024	39	2.750	2.000	5.875
6-4-6571-1	1710	2.024	39	2.750	2.000	5.875
6-4-6601	1710	2.374	46	3.752	2.422	4.938
6-4-6601-1	1710	2.374	46	3.752	2.422	4.938
6-4-6611	1710	2.500	10	3.750	3.000	5.625
6-4-6611-1	1710	2.500	10	3.750	3.000	5.625
6-4-6631	1710	2.750	10	3.750	3.000	5.750
6-4-6631-1	1710	2.750	10	3.750	3.000	5.750
6-4-6821	1710	2.750	10	3.750	3.000	5.750
6-4-6821-1	1710	2.750	10	3.750	3.000	5.750
6-4-6841-1X	1710	2.750	10	3.750	3.000	5.750
6-4-6841X	1710	2.750	10	3.750	3.000	5.750

Part Number	Series	Splines Data		Ground Hub Dia.	Length Thru Hole	*C/L to End of Hub
		O.D.	No. Teeth			
6-4-6861	1710	2.250	10	3.500	3.000	5.250
6-4-6861-1	1710	2.250	10	3.500	3.000	5.250
6-4-6871-1X	1710	2.024	39	2.750	2.438	6.500
6-4-6871X	1710	2.024	39	2.750	2.438	6.500
6-4-6891X	1710	2.250	10	3.000	3.000	7.188
6-4-6901-1X	1710	2.250	10	3.500	3.000	5.250
6-4-6901X	1710	2.250	10	3.500	3.000	5.250
6-4-6921-1X	1710	2.500	10	3.750	3.000	5.625
6-4-6921X	1710	2.500	10	3.750	3.000	5.625
6-4-6931-1X	1710	2.750	10	3.750	3.000	5.750
6-4-6931X	1710	2.750	10	3.750	3.000	5.750
6-4-6941X	1710	2.024	39	2.750	2.438	4.812
6-4-6951-1X	1710	2.024	39	2.750	2.438	5.250
6-4-6951X	1710	2.024	39	2.750	2.438	5.250
6-4-6961-1X	1710	2.374	46	3.250	2.875	5.938
6-4-6961X	1710	2.374	46	3.250	2.875	5.938
6-4-6971	1710	2.364	18	3.750	2.344	5.094
6-4-6971-1	1710	2.364	18	3.750	2.344	5.094
6-4-7041-1X	1710	2.544	49	3.755	3.000	5.625
6-4-7041X	1710	2.544	49	3.755	3.000	5.625
6-4-7051	1710	2.544	49	3.755	3.000	5.625
6-4-7051-1	1710	2.544	49	3.755	3.000	5.625
6-4-7071-1X	1710	2.635	20	3.750	2.750	5.188
6-4-7071X	1710	2.635	20	3.750	2.750	5.188
6-4-7161	1710	2.390	46	3.250	2.328	5.391
6-4-7161-1	1710	2.390	46	3.250	2.328	5.391
6-4-7171X	1710	2.114	32	3.000	2.250	6.250
6-4-7181-1X	1710	2.390	46	3.250	2.328	5.391
6-4-7181X	1710	2.390	46	3.250	2.328	5.391
6-4-7191X	1710	2.364	36	3.000	2.688	5.438
6-4-7201	1710	2.364	36	3.000	2.688	5.438
6-4-7211X	1710	2.364	36	3.000	2.688	5.438
6-4-7221X	1710	2.114	32	3.000	2.250	4.562
6-4-7231X	1710	1.989	30	3.000	2.700	6.280
6-4-7241X	1710	2.364	36	3.000	2.688	6.500
6-4-7251	1710	2.343	45	3.750	3.000	5.250
6-4-7251-1	1710	2.343	45	3.750	3.000	5.250
6-4-7271-1X	1710	2.343	45	3.750	3.000	5.250
6-4-7271X	1710	2.343	45	3.750	3.000	5.250
6-4-7301	1710	1.998	38	2.750	2.125	5.250
6-4-7301-1	1710	1.998	38	2.750	2.125	5.250
6-4-7311	1710	2.143	41	2.938	2.500	5.190
6-4-7311-1	1710	2.143	41	2.938	2.500	5.190
6-4-7321-1X	1710	2.143	41	2.938	2.500	5.190
6-4-7371-1	1710	2.250	10	3.750	3.000	5.250
6-4-7381-1X	1710	2.250	10	3.750	3.000	5.250
6-4-7511	1710	2.390	46	3.375	3.188	6.000
6-4-7511-1	1710	2.390	46	3.375	3.188	6.000
6-4-7531-1X	1710	2.390	46	3.375	3.188	6.000
6-4-7531X	1710	2.390	46	3.375	3.188	6.000
6-4-7541	1710	2.143	41	2.938	3.000	6.625
6-4-7541-1	1710	2.143	41	2.938	3.000	6.625
6-4-7551	1710	2.143	41	2.938	2.500	6.125
6-4-7551-1	1710	2.143	41	2.938	2.500	6.125
6-4-7561-1X	1710	2.143	41	2.938	2.500	6.125

Part Number	Series	Spline Data		Ground Hub Dia.	Length Thru Hole	*C/L to End of Hub	Part Number	Series	Spline Data		Ground Hub Dia.	Length Thru Hole	*C/L to End of Hub
		O.D.	No. Teeth						O.D.	No. Teeth			
6-4-7561X	1710	2.143	41	2.938	2.500	6.125	6-4-8451-1	1710	2.274	44	3.000	2.500	5.190
6-4-7571-1	1710	1.790	34	2.625	2.188	5.438	6-4-8461	1710	2.274	44	2.938	2.500	5.188
6-4-7581-1X	1710	1.790	34	2.625	2.188	5.438	6-4-8461-1	1710	2.274	44	2.938	2.500	5.188
6-4-7621-1	1710	2.024	39	3.000	2.312	5.156	6-4-8511-1X	1710	1.790	34	2.625	2.438	5.438
6-4-7631-1X	1710	2.024	39	3.000	2.312	5.156	6-4-8511X	1710	1.790	34	2.625	2.438	5.438
6-4-7641-1X	1710	2.024	39	3.000	2.312	5.156	6-4-8521-1X	1710	1.790	34	2.625	2.438	6.312
6-4-7651-1X	1710	2.143	41	2.938	3.000	6.625	6-4-8521X	1710	1.790	34	2.625	2.438	6.312
6-4-7651X	1710	2.143	41	2.938	3.000	6.625	6-4-8531-1X	1710	2.024	39	2.625	2.250	5.250
6-4-7661-1	1710	2.750	10	3.812	3.000	5.750	6-4-8531X	1710	2.024	39	2.625	2.250	5.250
6-4-7691	1710	2.544	49	4.000	2.750	5.188	6-4-8541-1X	1710	2.024	39	2.625	2.250	6.125
6-4-7691-1	1710	2.544	49	4.000	2.750	5.188	6-4-8541X	1710	2.024	39	2.625	2.250	6.125
6-4-7761	1710	2.390	46	3.250	2.344	6.500	6-4-8551-1X	1710	2.274	44	2.938	2.500	5.188
6-4-7761-1	1710	2.390	46	3.250	2.344	6.500	6-4-8551X	1710	2.274	44	2.938	2.500	5.188
6-4-7771-1X	1710	2.390	46	3.250	2.344	6.500	6-4-8571-1X	1710	2.024	39	3.000	2.312	6.250
6-4-7771X	1710	2.390	46	3.250	2.344	6.500	6-4-8571X	1710	2.024	39	3.000	2.312	6.250
6-4-7831	1710	2.374	46	3.250	2.891	6.938	6-4-8601-1X	1710	2.024	39	3.000	2.312	5.156
6-4-7831-1	1710	2.374	46	3.250	2.891	6.938	6-4-8651-1	1710	1.998	38	3.000	2.125	4.844
6-4-7851-1X	1710	2.374	46	3.250	2.891	6.938	6-4-8661-1X	1710	1.998	38	3.000	2.125	4.844
6-4-7851X	1710	2.374	46	3.250	2.891	6.938	6-4-8671-1	1710	2.114	32	3.000	2.250	4.562
6-4-7881-1X	1710	2.374	46	3.752	2.422	4.938	6-4-8681-1X	1710	2.114	32	3.000	2.250	4.562
6-4-7881X	1710	2.374	46	3.752	2.422	4.938	6-4-8691-1	1710	2.364	36	3.000	2.688	5.438
6-4-7891-1X	1710	2.374	46	3.752	2.422	4.938	6-4-8701-1X	1710	2.364	36	3.000	2.688	5.438
6-4-7961	1710	2.274	44	2.938	2.359	5.031	6-4-8711-1	1710	2.364	36	3.000	2.688	5.438
6-4-7961-1	1710	2.274	44	2.938	2.359	5.031	6-4-8721-1X	1710	2.364	36	3.000	2.688	5.438
6-4-7971-1X	1710	2.274	44	2.938	2.359	5.031	6-4-8731-1	1710	1.989	30	3.000	2.703	6.281
6-4-7971X	1710	2.274	44	2.938	2.359	5.031	6-4-8751-1	1710	2.114	32	3.000	2.250	6.062
6-4-7981	1710	2.024	39	2.625	2.250	6.125	6-4-8761-1X	1710	2.114	32	3.000	2.250	6.062
6-4-7981-1	1710	2.024	39	2.625	2.250	6.125	6-4-8771-1	1710	2.364	36	3.000	2.703	6.500
6-4-7991	1710	2.024	39	2.625	2.250	5.250	6-4-8781-1X	1710	2.364	36	3.000	2.703	6.500
6-4-7991-1	1710	2.024	39	2.625	2.250	5.250	6-4-8791-1	1710	2.364	36	3.500	2.500	5.234
6-4-8001	1710	1.790	34	2.625	2.438	6.312	6-4-8801-1X	1710	2.364	36	3.500	2.500	5.234
6-4-8001-1	1710	1.790	34	2.625	2.438	6.312	6-4-8951-1	1710	2.374	46	3.500	2.406	5.840
6-4-8081	1710	1.790	34	2.625	2.438	5.438	6-4-8961-1X	1710	2.374	46	3.500	2.406	5.840
6-4-8081-1	1710	1.790	34	2.625	2.438	5.438	6-4-8981-1X	1710	2.274	44	3.000	2.500	5.190
6-4-8231-1X	1710	2.024	39	2.625	2.250	5.250	6-4-8981X	1710	2.274	44	3.000	2.500	5.190
6-4-8271-1	1710	2.250	10	3.312	2.250	5.297	6-4-8991-1X	1710	2.024	39	3.000	2.281	6.125
6-4-8281-1X	1710	2.250	10	3.312	2.250	5.297	6-4-8991X	1710	2.024	39	3.000	2.281	6.125
6-4-8291-1X	1710	2.260	06	3.250	2.250	5.300	6-4-9001-1X	1710	2.024	39	2.625	2.500	6.125
6-4-8321-1X	1710	2.500	10	3.500	2.406	5.156	6-4-9001X	1710	2.024	39	2.625	2.500	6.125
6-4-8331-1X	1710	2.024	39	2.750	2.000	5.000	6-4-9021-1	1710	1.790	34	2.500	2.250	4.875
6-4-8331X	1710	2.024	39	2.750	2.000	5.000	6-4-9031-1X	1710	2.024	39	3.000	2.281	5.250
6-4-8341-1X	1710	2.374	46	3.500	2.406	5.156	6-4-9031X	1710	2.024	39	3.000	2.281	5.250
6-4-8341X	1710	2.374	46	3.500	2.406	5.156	6-4-9041-1X	1710	2.024	39	2.625	2.500	5.250
6-4-8351-1X	1710	2.500	10	3.500	2.406	5.156	6-4-9041X	1710	2.024	39	2.625	2.500	5.250
6-4-8361-1X	1710	2.024	39	2.750	2.000	5.875	6-4-9161-1X	1710	2.274	44	2.938	2.359	5.031
6-4-8361X	1710	2.024	39	2.750	2.000	5.875	6-4-9161X	1710	2.274	44	2.938	2.359	5.031
6-4-8411	1710	2.024	39	3.000	2.281	6.125	6-4-9171-1X	1710	2.143	41	2.938	2.500	5.190
6-4-8411-1	1710	2.024	39	3.000	2.281	6.125	6-4-9171X	1710	2.143	41	2.938	2.500	5.190
6-4-8421	1710	2.024	39	3.000	2.281	5.250	6-4-9181-1X	1710	2.143	41	2.938	2.500	6.125
6-4-8421-1	1710	2.024	39	3.000	2.281	5.250	6-4-9181X	1710	2.143	41	2.938	2.500	6.125
6-4-8431	1710	2.024	39	2.625	2.500	6.125	6-4-9191-1X	1710	2.143	41	2.938	3.000	6.625
6-4-8431-1	1710	2.024	39	2.625	2.500	6.125	6-4-9191X	1710	2.143	41	2.938	3.000	6.625
6-4-8441	1710	2.024	39	2.625	2.500	5.250	6-4-9201-1X	1710	2.390	46	3.375	3.188	6.000
6-4-8441-1	1710	2.024	39	2.625	2.500	5.250	6-4-9221	1710	2.178	43	3.539	2.047	4.875
6-4-8451	1710	2.274	44	3.000	2.500	5.190	6-4-9221-1	1710	2.178	43	3.539	2.047	4.875

Part Number	Series	Spline Data		Ground Hub Dia.	Length Thru Hole	*C/L to End of Hub
		O.D.	No. Teeth			
6-4-9231	1710	2.794	54		2.750	5.625
6-4-9231-1	1710	2.794	54		2.750	5.625
6-4-9281-1	1710	2.024	39	3.000	2.500	6.120
6-4-9291-1	1710	2.024	39	3.000	2.250	6.000
6-4-9301-1X	1710	2.024	39	3.000	2.250	6.000
6-4-9411-1	1710	2.024	39	3.000	2.500	5.438
6-4-9421-1	1710	2.024	39	3.000	2.250	4.656
6-4-9431-1X	1710	2.024	39	3.000	2.250	4.656
6-4-9441-1X	1710	2.024	39	3.000	2.250	4.656
6-4-9531-1X	1710	2.390	46	3.250	2.312	5.125
6-4-9841-1X	1710	2.149	16	2.938	3.000	6.625
6-4-9841X	1710	2.149	16	2.938	3.000	6.625
6-4-9951-1	1710	1.998	38	3.000	2.125	4.840
6-4-9961-1X	1710	1.998	38	3.000	2.125	4.840
70-4-01789-1X	SPL70	1.790	34	2.562	2.750	6.650
70-4-03330-1X	SPL70	2.024	39	3.000	1.847	3.875
70-4-06977X	SPL70	2.024	39	3.000	1.844	3.878
70-4-101-1	SPL70	2.024	39	3.000	2.281	4.281
70-4-111-1X	SPL70	2.024	39	3.000	2.281	4.281
70-4-141-1	SPL70	2.143	41	2.938	2.500	4.555
70-4-151-1X	SPL70	2.143	41	2.938	2.500	4.555
70-4-161-1	SPL70	1.750	10	2.500	2.000	5.750
70-4-171-1X	SPL70	1.750	10	2.500	2.000	5.750
70-4-181-1	SPL70	1.790	34	2.564	2.750	5.530
70-4-191-1X	SPL70	1.790	34	2.564	2.750	5.530
70-4-51-1	SPL70	1.790	34	2.375	2.188	4.000
70-4-61-1X	SPL70	1.790	34	2.375	2.188	4.000
8-4-1141	9C/1820	2.375	46	3.750	2.375	3.938
8-4-1151X	9C/1820	2.375	46	3.750	2.375	3.938
8-4-1161X	9C/1820	2.375	46	3.750	2.375	3.938
8-4-1231	1880	2.625	20	3.000	2.750	6.270
8-4-1241	1880	2.750	10	3.375	2.938	6.370
90-4-05379-1X	SPL90	2.024	39	2.626	2.245	4.160
90-4-111-1	SPL90	1.998	38	2.750	2.125	7.562
90-4-151-1X	SPL90	2.250	10	3.500	3.000	5.219
90-4-161-1	SPL90	2.250	10	3.750	3.000	5.219
90-4-171-1X	SPL90	2.250	10	3.750	3.000	5.219
90-4-181-1	SPL90	1.790	34	2.562	2.750	5.609
90-4-191-1X	SPL90	1.790	34	2.562	2.750	5.609
90-4-21-1	SPL90	2.000	10	2.750	3.000	4.969
90-4-241-1	SPL90	2.024	39	3.000	2.281	4.750
90-4-251-1X	SPL90	2.024	39	3.000	2.281	4.750
90-4-281-1	SPL90	2.281	44	2.938	2.344	4.469
90-4-311-1	SPL90	2.024	39	3.000	2.312	4.625
90-4-321-1X	SPL90	2.024	39	3.000	2.312	4.625
90-4-331-1	SPL90	2.390	46	3.250	2.312	4.641
90-4-341-1X	SPL90	2.390	46	3.250	2.312	4.641
90-4-351-1	SPL90	2.374	46	3.250	2.875	5.188
90-4-361-1X	SPL90	2.374	46	3.250	2.875	5.188
90-4-371-1	SPL90	1.750	10	2.500	1.938	4.125
90-4-381-1	SPL90	1.962	10	2.750	2.781	4.984
90-4-391-1	SPL90	1.998	38	2.750	2.125	4.250
90-4-401-1	SPL90	2.250	10	3.500	3.000	5.219
90-4-461-1	SPL90	1.790	34	2.562	2.750	5.625
90-4-471-1	SPL90	2.141	41	2.938	2.500	4.562

Part Number	Series	Spline Data		Ground Hub Dia.	Length Thru Hole	*C/L to End of Hub
		O.D.	No. Teeth			
90-4-501-1X	SPL90	1.790	34	2.562	2.750	5.625
90-4-541-1	SPL90	1.790	34	2.375	2.188	5.625
90-4-551-1X	SPL90	1.790	34	2.375	2.188	5.625
90-4-561-1	SPL90	1.998	38	3.000	2.125	4.250
90-4-571-1X	SPL90	1.998	38	3.000	2.125	4.250
90-4-581-1	SPL90	2.114	32	3.000	2.250	4.375
90-4-591-1X	SPL90	2.114	32	3.000	2.250	4.375
90-4-601-1	SPL90	2.364	36	3.000	2.688	4.812
90-4-611-1X	SPL90	2.364	36	3.000	2.688	4.812
90-4-621-1	SPL90	2.024	39	2.626	2.245	4.160
90-4-631-1X	SPL90	2.024	39	2.626	2.245	4.160
90-4-691-1X	SPL90	2.141	41	2.938	2.500	4.562
90-4-71-1	SPL90	1.998	38	2.750	2.125	4.000
90-4-751-1	SPL90	1.774	34	2.500	2.250	4.110
90-4-761-1X	SPL90	1.774	34	2.500	2.250	4.110
90-4-791-1	SPL90	2.178	43	3.547	2.031	4.625

Dana Aftermarket Group
PO Box 1000
Maumee, Ohio 43537

Warehouse Distributors: 1.800.621.8084
OE Dealers: 1.877.777.5360

www.SpicerParts.com

SPICER[®]



J300P-10 Printed in U.S.A.
Copyright Dana Limited, 2015.
All rights reserved. Dana Limited.

