



## Illustrated Parts List

---

### **Spicer® Drive Axles** **AXIP-4440** **February 2018**

22060SH, 22060DH, 23060SH, 23060DH,

P20060, P22060,

RSH40, RSH44, RSP40, RSP41,

RDH40, RDH44, RDP40, RDP41,

DSH40(P), DSH44(P), DSP40(P), DSP41(P),

DDH40(P), DDH44(P), DDP40(P), DDP41(P) Models

# IDENTIFY



# LOCATE



# ORDER



# TRACK



# SIMPLIFIED.



[DanaAftermarket.com](http://DanaAftermarket.com)

**SPICER**<sup>®</sup>



**It's never been easier to do business with Dana.**

You've spoken. We've listened. Easily access the genuine Spicer parts information you need to succeed. Search by part number, product type, product line, keywords, and year-make-model. Place and track your orders. It's all here to help streamline your operations and grow your business.

Experience the new one-stop solution from Spicer today!

General Information..... 2

How To Use Illustrated Parts List ..... 2

Model Identification ..... 3

Single Reduction - Forward Axles - After June 2008 ..... 5  
 DDH40(P), DDH44 (P), DDP40(P), DDP41(P), DSH40(P), DSH44(P), DSP40(P), DSP41(P)

Pinion Bearing Spacers ..... 9

Single Reduction - Forward Axles - Before June 2008..... 10  
 DDH40(P), DDH44 (P), DDP40(P), DDP41(P), DSP40(P), DSP41(P) DSH40(P), DSH44(P)

Wheel Differential Lock Assembly & Parts..... 14

Rear Axle Parts Explode..... 15  
 22060DH, 22060SH, 23060DH, 23060SH, P20060, P22060, RDH40, RDH44, RDP40,  
 RDP41, RSH40, RSH44, RSP40, RSP41 Output Shaft & Axle Housing Parts Explode ..... 17

Carrier Mounting Flange Design Change—Thick and Thin Flanges..... 19

Axle Housing Fastener Kits ..... 19

Axle Shafts & Axle Shaft Hardware Parts..... 20

Gear & Pinion Kits ..... 21

Service Carriers - Single Reduction All Models ..... 23

Yokes & Flanges ..... 27

Oil Seal Installation Tools ..... 28

Service Kit Reference Listing ..... 29

Power Divider Kits Reference Pages.....8, 13, 29

## How to Use Illustrated Parts List

### ORDERING PARTS

- This parts book is organized in sections according to parts servicing requirements. Use the Contents or page headings and colored tabs to find information.
- Use this book to order parts for your Dana® Spicer® Axle.
- For convenience, part numbers have been included for all pieces of the carrier assembly. Some of these parts, such as the carrier and caps, are serviced only in kits or assemblies. Part numbers are for your reference only. Those parts not serviced separately are identified with NSS.

### KITS AND ASSEMBLIES

- Kits and Assemblies contain groups of individual or assembled parts developed for optimal replacement or repair of a service problem.
- Kits and Assemblies are shown with applicable parts groupings in the parts listing.
- See the Appendix for detailed information concerning kits applicable to this model.

### ABBREVIATIONS

- ABS - Antilock Brake System
- AR - As Required - Parts that vary in quantity with each axle. Example: shims
- Assy - Assembly
- Brg - Bearing
- Diff - Differential
- Hsg - Housing
- Inv - Involute
- N/A - Not Applicable
- NSS - Not Serviced Separately - Items which can only be purchased in sets, kit form or service assemblies. Example: brake shoes.
- RH/LH - Right Hand/Left Hand - Determined as viewed from behind the vehicle looking forward.
- RTV - Gasket Compound - Formed-in-place gasket sealer. It is recommended for use on all surfaces requiring a gasket.
- Str - Straight

### ILLUSTRATIONS

- Illustrations show parts in assembly groups.

- Item numbers on illustrations correspond with parts listings on pages that accompany the drawings.
- Notes are included on illustrations where needed.

### PARTS LISTINGS

- Parts listings are defined by parts groupings and are broken down by service assemblies.
- Parts Listings identify a part for servicing with the following categories:
  - Item - corresponds with numbers on illustrations for part identification
  - Part Name - specifies part name or description
  - Quantity (Qty) - quantity required for assembly
- Current Part - service part numbers are broken down by model, type or other applicable information
- Notes - define unique characteristics or replacement notes
- Kits / Assy Where Used - indicates Kits or Assemblies that contain a particular part
- Other pertinent information is listed in tables or parts listings as required.

## Effectively Using a Parts Listing - Example

### FOLLOW THE EXAMPLE BELOW TO LOCATE AND ORDER EXACTLY WHAT IS REQUIRED FOR SERVICING.

Match to items on illustration	Use to identify Part #	Order this quantity for servicing	Order part # by model indicated		Indicates information important to ordering or use
Item	Description	Qty	DSP40(P)	DDP40(P)	Notes
7	Brg Cup - Plain Half	1	134301•	15092•	134301 replaces 129566
8	Brg Cone - Plain Half	1	134300•	128604•	134300 replaces 129565

### SUMMARY OF KITS AND ASSEMBLIES

Oil Seal & Shim Kit	216224	216224	Includes 49-54 & 127592
Basic Overhaul Kit	510393	510393	Contents Identified with *

## Model Identification

### LOCATING MODEL DESIGNATION INFORMATION

- Axle Model Identification, Part Number and Serial Number are located on a tag at the axle centerline. This information will help to locate information in this book and to identify the correct parts for servicing.

### DRIVE AXLES

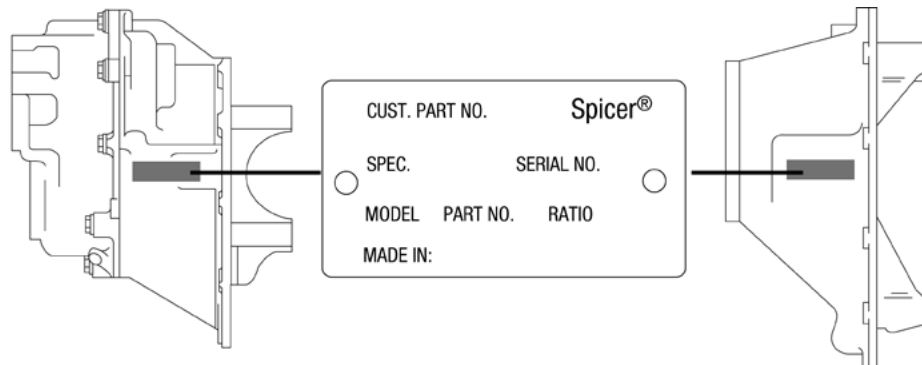

- Model Number, Part Number and Serial Number are located on the data plate on the axle centerline

### DRIVE AXLE ASSEMBLY TAG

1. Country or origin
2. Axle model identification
3. Specification number assigned to the axle built by Spicer®. Identifies all component parts of the axle including special OEM requirements such as yokes or flanges
4. OEM part number assigned to the axle build
5. Carrier assembly serial number assigned by the manufacturing plant
6. Axle gear ratio
7. Carrier assembly production or service part number

*NOTE: When inquiring about specific information on your axle, write down all of the above information from your tag and call your local OEM dealer or your Roadranger representative.*

The axles illustrated in this book are specified with a variety of different axle shafts, according to OEM specifications. When ordering replacement axle shafts note the part number stamped into the flange.

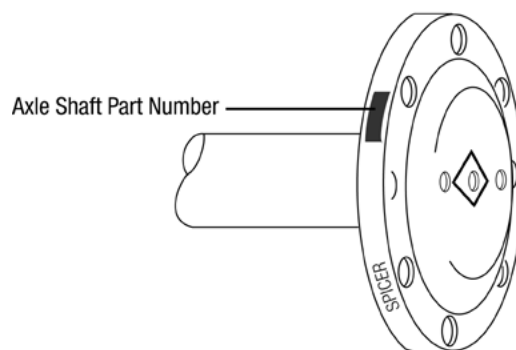

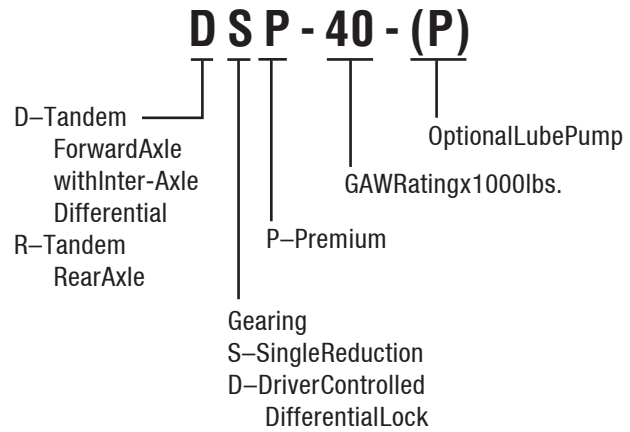

## Model Identification

### USING MODEL DESIGNATION TO IDENTIFY AXLE COMPONENTS

- The Axle Model Identification number contains information that is important to understand when purchasing service parts or new components. The Model Identification number provides important vehicle capacity and application information and model features. Use this guideline to understand your Axle Model Identification. If you need assistance contact your Roadranger representative.

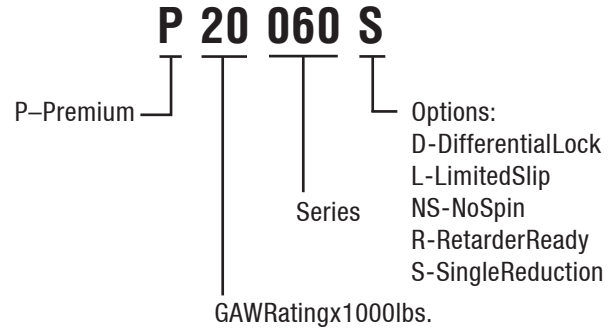

## Models

The following models are included in this publication:

### SINGLE REDUCTION MODELS

Single Axle*	Axle Capacity	Gear Size
P20060	20,000 Lbs	15.40"/15.65" Hypoid Gear, Nom.
P22060	22,000 Lbs	15.40"/15.65" Hypoid Gear, Nom.
22060SH	22,000 Lbs	15.40"/15.70" Hypoid Gear, Nom.
22060SH	23,000 Lbs	15.40"/15.70" Hypoid Gear, Nom.

\*carrier options include S=Single Speed, D=Differential Lock, R=Parking Brake Ready

Forward Axle	Rear Axle	Axle Capacity	Gear Size
DSP40(P)	RSP40	40,000 Lbs	15.40"/15.65" Hypoid Gear, Nom.
DSP41(P)	RSP41	40,000 Lbs	15.40"/15.65" Hypoid Gear, Nom.
DSH40(P)	RSH40	40,000 Lbs	15.75" Hypoid Gear, Nom.
DSH44(P)	RSH44	44,000 Lbs	15.75" Hypoid Gear, Nom.

### SINGLE REDUCTION MODELS WITH WHEEL DIFFERENTIAL LOCK

Forward Axle	Rear Axle	Axle Capacity	Gear Size
DDP40(P)	RDP40	40,000 Lbs	15.40"/15.65" Hypoid Gear, Nom.
DDP41(P)	RDP41	40,000 Lbs	15.40"/15.65" Hypoid Gear, Nom.
DDH40(P)	RDH40	40,000 Lbs	15.75" Hypoid Gear, Nom.
DDH44(P)	RDH44	44,000 Lbs	15.75" Hypoid Gear, Nom.

# Single Reduction-Forward Axles After June 2008

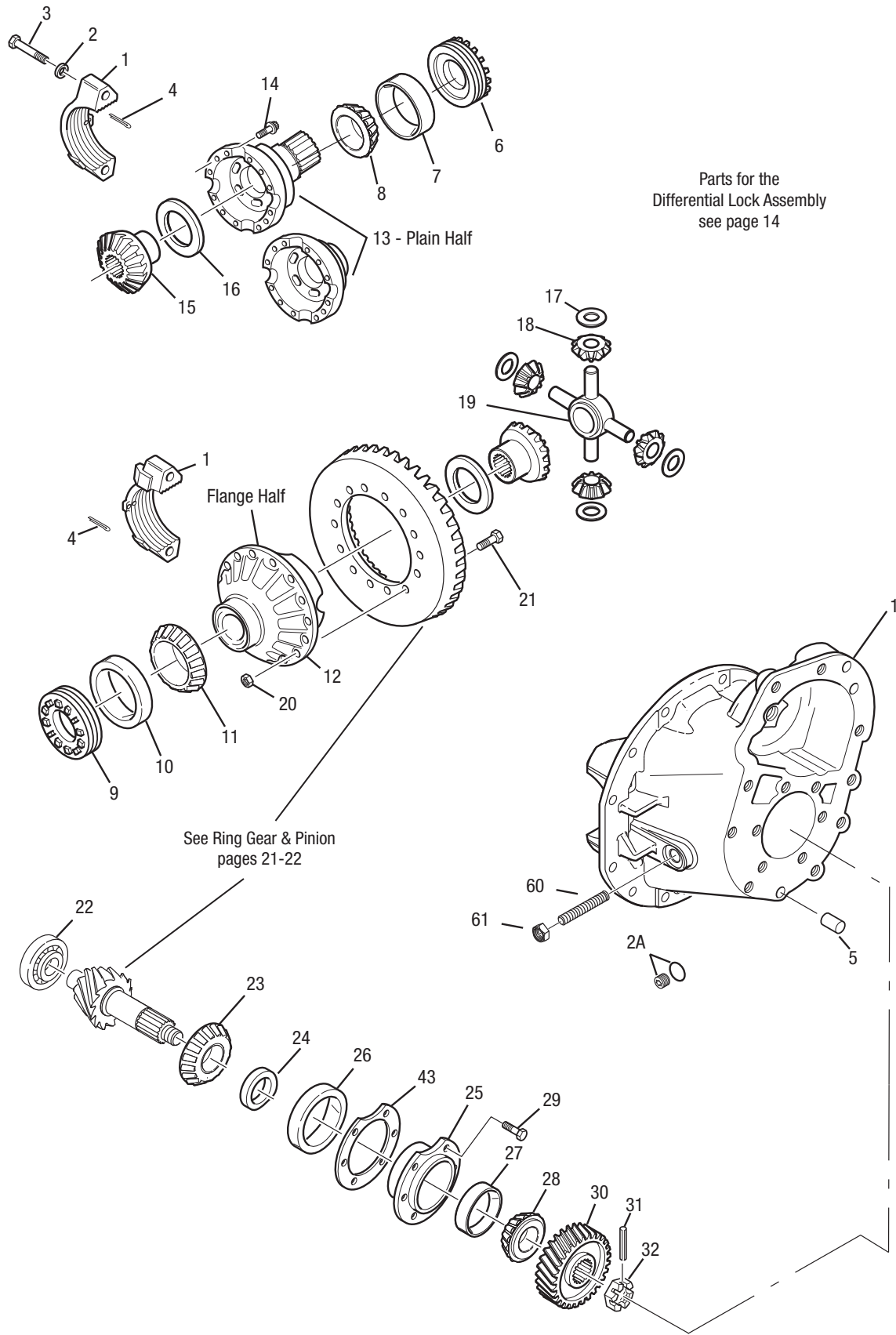

Parts for the  
Differential Lock Assembly  
see page 14

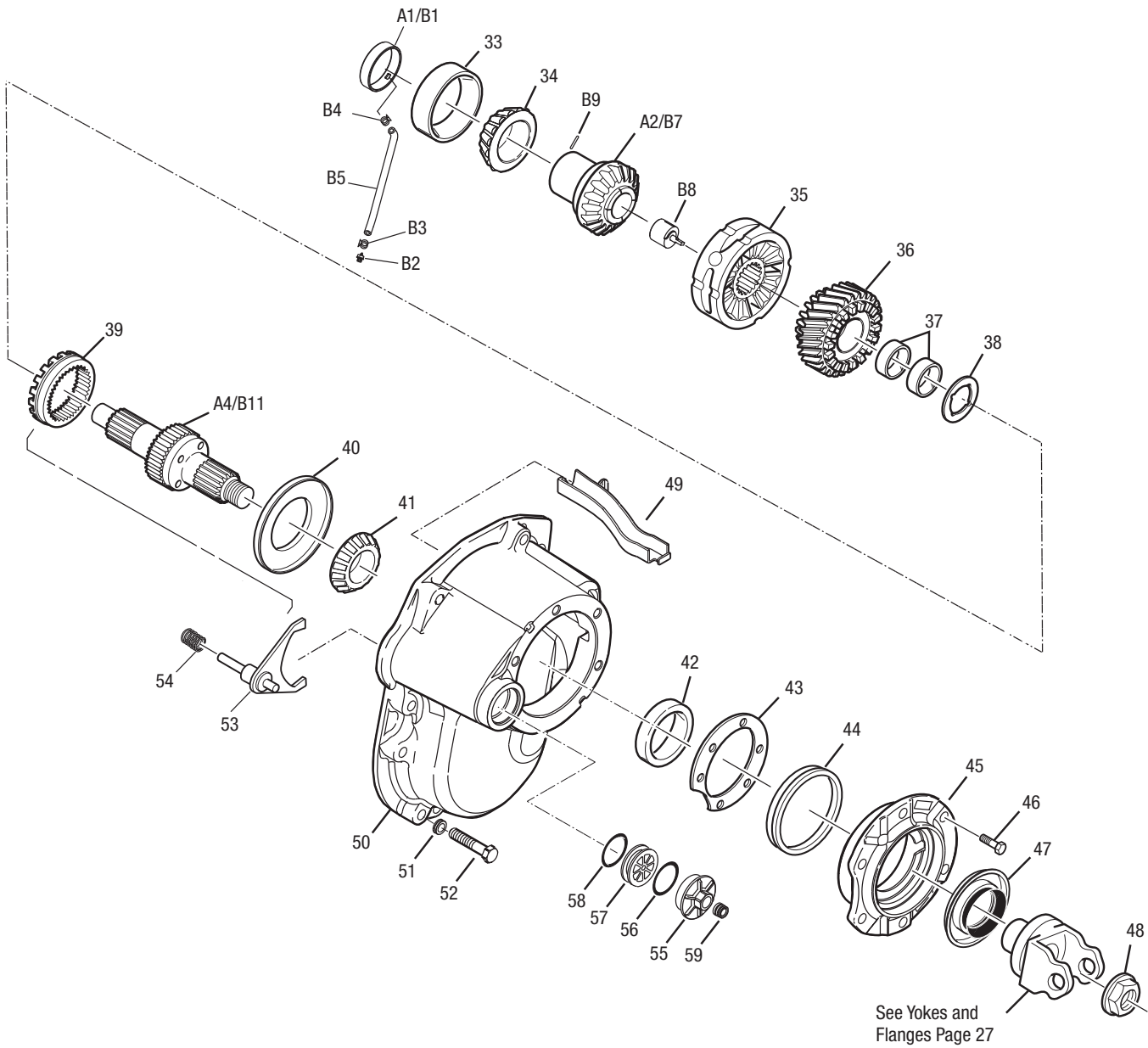



# Single Reduction-Forward Axles After June 2008



Item	Description	Qty	DSH40(P) DSH44(P) DSP40(P) DSP41(P)	DDH40(P) DDH44(P) DDP40(P) DDP41(P)	Notes
<b>BASIC OVERHAUL KIT</b>			504030	504031	Contents identified throughout chart below with *
<b>CARRIER REBUILD KIT</b>			504033	504034	Contents identified throughout chart below with †
1	Forward Carrier/Cap Sub-Assy				Includes items 1-3 and #33 brg cup
	Standard Mdls 132038-NSS	1	132466	---	
	Diff-Lock Mdls 132043-NSS	1	---	132467	
2	Flat Washer	4	210288	210288	
2A	Plug, O-Ring	1	131809	131809	O-ring not sold seperately
3	Capscrew	4	134481	134481	Replaces 210095
4	Cotter Pin	2	090873	090873	
5	Dowel Pin	2	007641	007641	
6	Diff Brg Adjuster - Plain Half	1	129130	128616	
7	Brg Cup - Plain Half	1	134301*†	134332*†	134301 replaces p/n 009803 & 129566, 134332 replaces 015092; see Dana bulletin # haxl-pni-33; <i>Brg pts must be used in mated sets</i>
8	Brg Cone - Plain Half	1	134300*†	134331*†	134300 replaces p/n 027813 & 129565. 134331 replaces 128604; see Dana bulletin # haxl-pni-33; <i>Brg pts must be used in mated sets</i>
9	Diff Brg Adjuster - Flange Half	1	129128	129128	
10	Brg Cup - Flange Half	1	134298*†	134298*†	Replaces 129564
11	Brg Cone - Flange Half	1	134297*†	134297*†	Replaces 134297
<b>WHEEL DIFF CASE KITS</b>					Includes items 12-14
12	Diff Case-RH (Flg Half)				
	129464	1	508653	508724	Ratios 2.64 to 3.08
	133738 (was 129465)		508654	508725	Ratios 3.25 to 3.90
	133739 (was 129466)		508655	508726	Ratios 4.11 to 4.88
	133740 (was 129467)		508656	508727	Ratios 5.29 to 7.17
13	Diff Case-LH (Plain Half)-Standard	1	132437	---	
	Diff Case-LH (Plain Half)-Diff Lock	1	---	128607	
14	Capscrew	12	127465	127465	
<b>WHEEL DIFF SIDE GEAR KIT</b>			510397	510397	Includes items 15-19
<b>WHEEL DIFF KIT w/o SIDE GEARS</b>			510396	510396	Includes items 16-19
15	Side Gear - 41 Inv Spline	2	127368	127368	
16	Side Gear Thrust Washer	2	127386*†	127386*†	
17	Side Pinion Thrust Washer	4	129305*†	129305*†	
18	Side Pinion	4	133784	133784	
19	Diff Spider	1	129599	129599	
<b>RING GEAR NUT &amp; BOLT KIT</b>			508652	508652	Includes items 20-21
20	Nut - Ring Gear	16	126216	126216	
21	Bolt - Ring Gear	16	10010020	10010020	Replaces 129686
22	Pinion Pilot Brg	1	10038915*†	10038915*†	Will replace 127484 in early 2018
23	Pinion Brg Cone - Inner	1	134291*†	134291*†	Replaces 129560
<b>24 PINION BRG SPACER KIT</b>			AR 504043	504043	Individual pinion bearing spacers listed on pg 9
25	Pinion Brg Cage & Cup Assy	1	134316	134316	Cage #127488C Includes item 25-27, replaces 129767
26	Pinion Brg Cup - Inner	1	134292*†	134292*†	Replaces 129561
27	Pinion Brg Cup - Outer	1	134295*†	134295*†	Replaces 012495
28	Pinion Brg Cone - Outer	1	134294*†	134294*†	Replaces 127535
29	Capscrew	6	210115	210115	
30	Pinion Helical Gear	1	127523	127523	
31	Roll Pin	1	118807	118807	
32	Slotted Pinion Nut	1	126182	126182	M42-1.5 (65mm socket)
<b>A MANIFOLD PARTS KIT- NON PUMP</b>			513880	513880	NON PUMP - Includes 132435
A1	Seal Manifold Assy - Non Pump #132435-NSS	1	---	---	NON PUMP - Must order kit
A2	Output Side Gear - Non Pump	1	132443	132443	NON PUMP
<b>A3 INPUT SHAFT KIT-NON PUMP</b>			504181	504181	NON PUMP - Includes 132447, 128049
A4	Input Shaft-Non Pump - #132447-NSS		---	---	Replaces 504026 See HAXL-PNI-073
<b>B MANIFOLD PARTS KIT - PUMP MODELS</b>			504029	504029	PUMP MODELS - Includes 133964, 134010, 129338, 134011, 131366
B1	Seal Manifold Assy Pump #131366-NSS	1	---	---	PUMP MODELS - Must order kit
B2	Filter Screen Assy	1	133964	133964	PUMP MODELS
B3	Collar Lock	1	134010	134010	PUMP MODELS
B4	Clamp	1	129338	129338	PUMP MODELS
B5	Lube Hose	1	134011	134011	PUMP MODELS
<b>B6 LUBE PUMP KIT</b>			504028	504028	PUMP MODELS - Includes 132060, 131541, 132061, 131368
B7	Output Side Gear - Pump Model	1	132061	132061	PUMP MODELS
B8	Lube Pump-Intregal	1	131368	131368	PUMP MODELS

Item	Description	Qty	DSH40(P) DSH44(P) DSP40(P) DSP41(P)	DDH40(P) DDH44(P) DDP40(P) DDP41(P)	Notes
B9	Pump Locking Pin	1	131541	131541	PUMP MODELS
<b>B10</b>	<b>IINPUT SHAFT- PUMP MODEL</b>	<b>1</b>	<b>504182</b>	<b>504182</b>	<b>PUMP MODELS - Includes 132446, 128049</b>
B11	Input Shaft-Pump Model #132446-NSS	—	—	—	Replaces 504027 See HAXL-PNI-073
33	Bearing Race	1	110811*†	110811*†	
34	Bearing Cone	1	132060*†	132060*†	
<b>POWER DIVIDER SERVICE KITS</b>					
	POWER DIVIDER KIT - MINOR AFTER JUNE 2008 PUMP MODELS		504404-3	504404-3	Includes items 35-36, B7-B8
	POWER DIVIDER KIT - MINOR AFTER JUNE 2008 NON-PUMP MODELS		504404-5	504404-5	Includes items 35-36, A2 
	POWER DIVIDER KIT - MAJOR AFTER JUNE 2008 PUMP MODELS		504404-4	504404-4	Includes items 35-36, 38, 48, B7-B8 & B11
	POWER DIVIDER KIT - MAJOR AFTER JUNE 2008 NON-PUMP MODELS		504404-6	504404-6	Includes items 35-36, 38, 48, A2 & A4
35	Inter-Axle Diff Assy	1	134192	134192	Replaces 128634, 129771
36	Helical Side Gear & Bushing	1	130907	130907	Includes item 37
	Assy Gear Stamp#130906-NSS				
37	Bushing - Helical Gear	2	129371	129371	
38	Thrust Washer - Helical Gear	1	132439*†	132439*†	
39	Lockout Sliding Clutch	1	127510	127510	
40	Oil Retainer	1	128700†	128700	
41	Input Shaft Bearing Cone	1	134303*†	134303*†	Replaces 129558
42	Bearing Cup	1	134304*†	134304*†	Replaces 1008912
<b>OIL SEAL &amp; SHIM KIT</b>					
		1	216224	216224	Includes shims, oil seals 127591 & 127592
<b>PINION CAGE SHIM KIT</b>					
		1	504032	504032	Includes 5 each of the shims listed
43	Shim.003"	AR	127595*†	127595*†	
	Shim.005"		127596*†	127596*†	
	Shim.010"		127597*†	127597*	
	Shim.020"		127598*†	127598*	
	Shim.030"		127599*†	127599*	
44	Oil Seal-V-Ring	1	128703*†	128703*	
45	Input Brg Cover Assy	1	134290	134290	Cast #129574C, Includes item 42, replaces 129575
46	Bearing Cover Cap Screw	6	210115	210115	
47	Oil Seal	1	127591*†	127591*†	
48	Locknut - Input	1	128049	128049	M42-1.5 (55mm socket)
49	Lube Trough	1	129577	129577	
50	Power Divider Cover	1	130823	130823	11 hole design
51	Washer - Capscrew	11	128415	128415	
52	Capscrew Long	11	210091	210091	
	Capscrew Special Double Ended Option	4	133746	133746	Qty-4 special capscrews used in some special applications along with qty-7 210091
<b>SHIFT FORK &amp; COMPRESSION SPRING KIT</b>					
		1	510870	510870	Includes Items 53 & 54
53	Shift Fork Assy - NSS	1	129856	129856	Order kit 510870
54	Compression Spring	1	129859	129859	
55	Piston Cover Assy	1	129573	129573	Includes cover #129578 and item 56
56	O-Ring	1	129579	129579	
57	Piston	1	129580	129580	
58	O-Ring	1	210180	210180	
59	Shipping Plug	1	599792	599792	
60	Thrust Screw	1	126193	126193	
61	Jam Nut	1	210184	210184	
62	RTV - Sealant 3oz	1	107276S*	107276S*	Not Illustrated

NSS - Not Sold Separately

**SUMMARY OF KITS AND ASSEMBLIES**

Air L/O Kit - Complete	510052	Includes: 53-59
Air L/O Repair Kit	510053	Includes: 55-58
Shift Fork & Compression Spring Kit	510870	Includes: 53-54

The pinion bearing spacers shown below come in a variety of different thicknesses for use in re-assembly. All are available individually or customers can order the PINION BRG SPACER SERVICE KIT, which has a selected range of popular bearing spacers.

**DDH40(P), DDH44 (P), DDP40(P), DDP41(P), DSH40(P), DSH44(P), DSP40(P), DSP41(P)**

**22060SH, P20060S/D, P22060S/D, RDH40, RDH44, RDP40, RDP41, RSH40, RSH44, RSP40, RSP41,**

**PINION BRG SPACER KIT: 504043 (INCLUDES ITEMS WITH \*)**

**PINION BRG SPACER KIT: 504016 (INCLUDES ITEMS WITH \*)**

Part #	Spacer Thickness
129079	0.797
129080	0.798
129081	0.800
129082	0.801
129083	0.802
129084	0.803
129085	0.804
129086*	0.806
129087	0.807
129088	0.808
129089	0.809
129090*	0.810
129091	0.811
129093	0.812
129097	0.814
129099*	0.815
129101	0.816
129103*	0.817
129105	0.818
129107	0.819
129109*	0.820
129111	0.821
129113	0.822
129115	0.823
129117*	0.824
129119	0.825
129120*	0.826
129121	0.828
129122	0.829
129123	0.830
129124*	0.831
129125	0.832
129126	0.833

Part #	Spacer Thickness
91552*	0.623
91553	0.624
91554	0.625
91555	0.626
91556*	0.627
91557	0.628
91558	0.629
91559*	0.630
91560	0.631
91561	0.632
91562	0.633
91564	0.634
91566	0.635
91568	0.636
91572*	0.637
91576	0.638
91580*	0.639
91584	0.640
91588	0.641
91592	0.642
91596*	0.643
91600	0.644
91602*	0.645
91604	0.646
91606	0.647
91608	0.648
91610	0.649
91611	0.650
91612	0.651
91613	0.652
91614*	0.653
91615	0.654

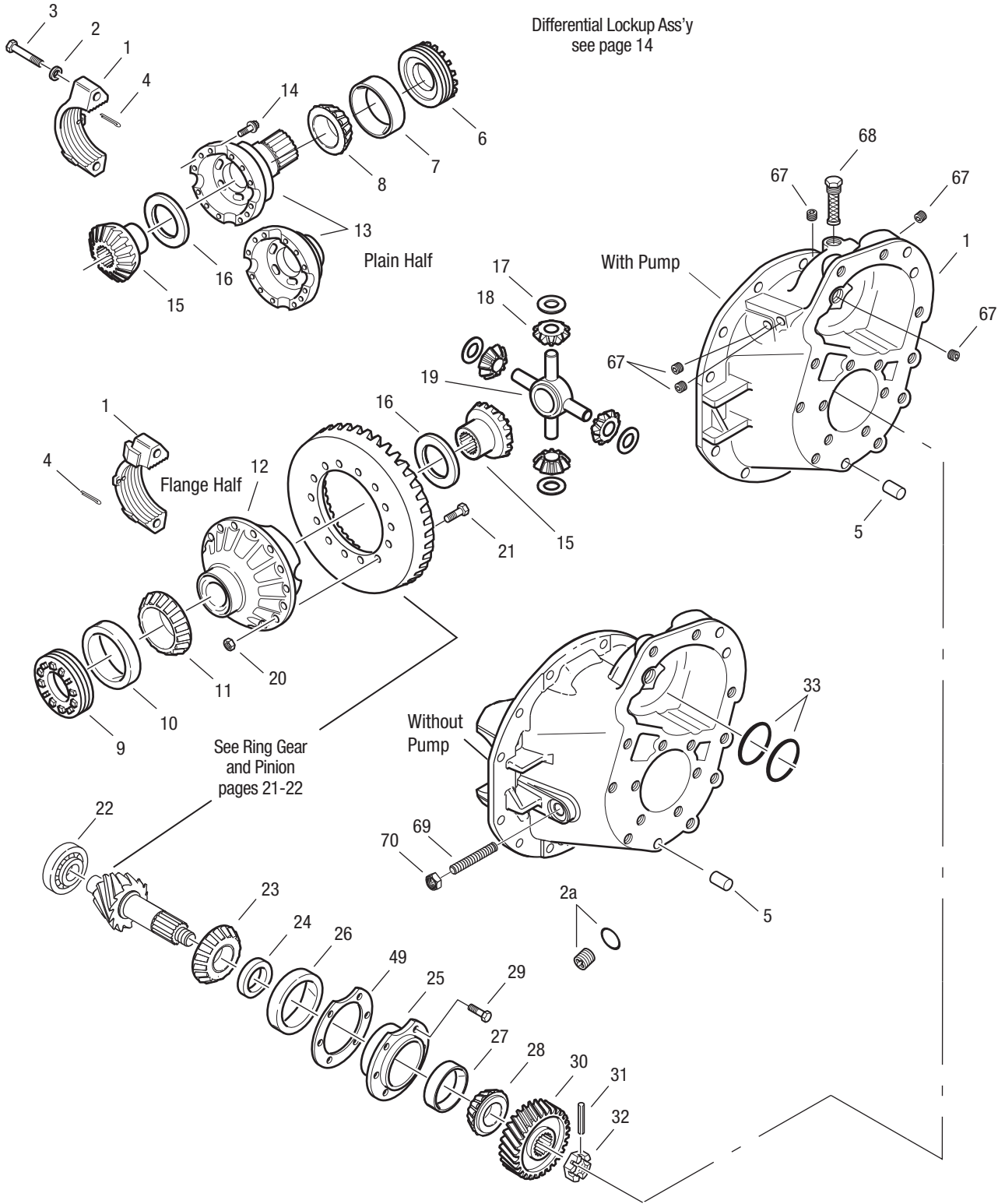

Single Reduction-Forward Axles  
Before June 2008

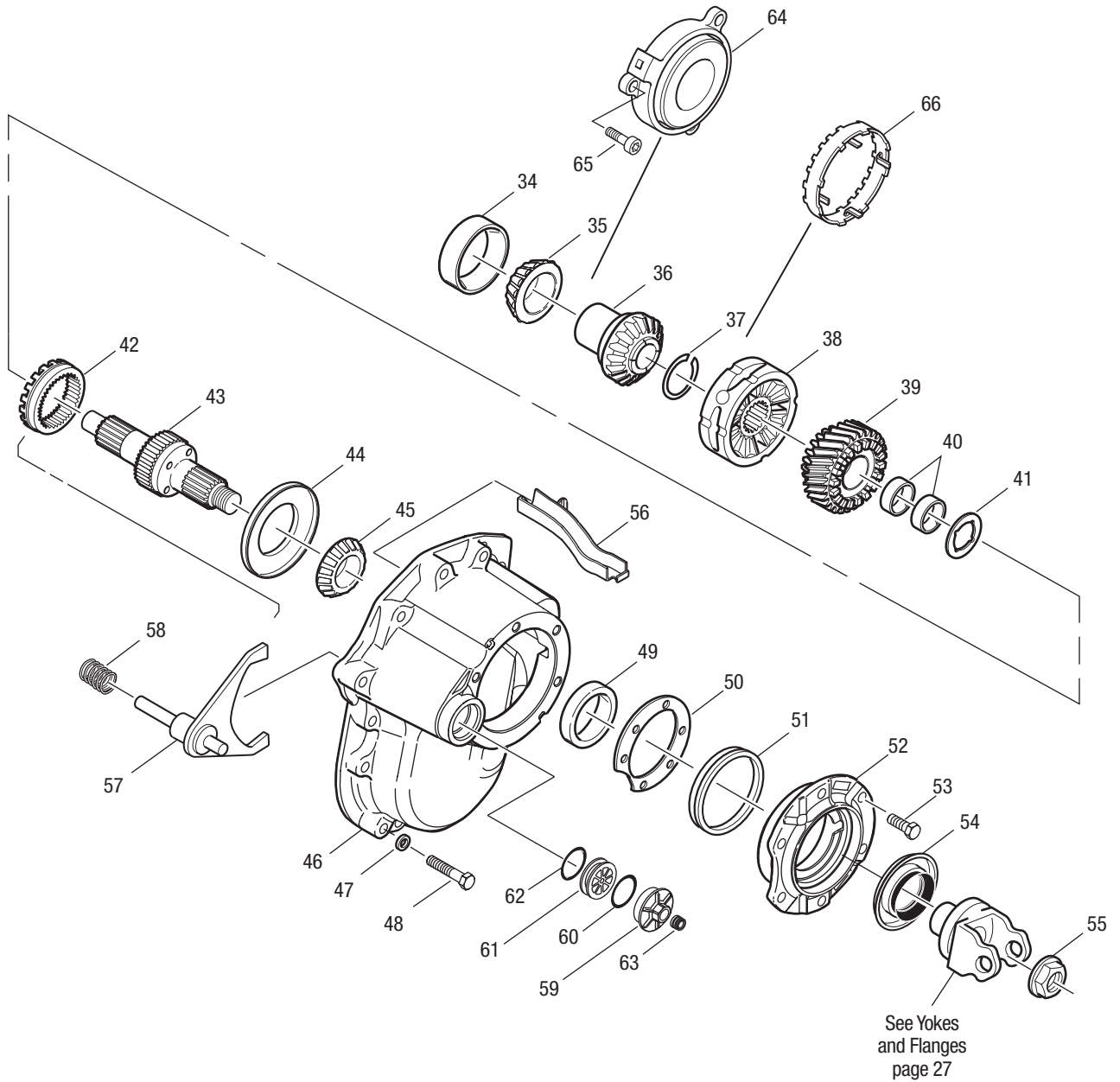

Item	Description	Qty	DSH40(P) DSH44(P) DSP40(P) DSP41(P)	DDH40(P) DDH44(P) DDP40(P) DDP41(P)	Notes
<b>BASIC OVERHAUL KIT</b>					
			510393	510399	Contents identified throughout chart below with *
<b>BEARING KIT</b>					
			512812	512800	Contents identified throughout chart below with †
<b>CARRIER REBUILD KIT</b>					
			504161	N/A	Contents identified throughout chart below with ‡
1	Diff Carr & Brg Caps Kits-NLA See Chart and Notes Below				
			<b>Model Type</b>	<b>Part #</b>	<b>Notes</b>
	Included: 1-3, 5, 67, 69-71 and fasteners from 512087 pg 18 note 1		DSP40, DSP41	510023-NLA	Casting #130809
	<i>NOTE: All Original Carr/Caps are NLA, must purchase complete carrier. Refer to bulletin abib-0805</i>		DSP40P, DSP41P	510024-NLA	Casting #130819
			DDP40, DDP41	510027-NLA	Casting #130814
			DDP40P, DDP41P	510028-NLA	Casting #130814
2	Flat Washer	4	210288	210288	
2A	Plug & O-Ring Assembly	1	131809	131809	O-ring not sold separately
3	Capscrew	4	134481	134481	Replaces 210095
4	Cotter Pin	2	090873	090873	Replaces 126156
5	Dowel Pin	2	007641	007641	
6	Diff Brg Adjuster - Plain Half	1	129130	128616	
7	Brg Cup - Plain Half	1	134301*†‡	134332*†	134301 replaces p/n 009803 & 129566. 134332 replaces 015092 see Dana bulletin# haxl-pni-33 <i>Brg pts must be used in mated sets</i>
8	Brg Cone - Plain Half	1	134300*†‡	134331*†	134300 replaces p/n 027813 & 129565. 134331 replaces 128604 see Dana bulletin# haxl-pni-33 <i>Brg pts must be used in mated sets</i>
9	Diff Brg Adjuster - Flange Half	1	129128	129128	
10	Brg Cup - Flange Half	1	134298*†‡	134298*†	Replaces 129564 & 90943
11	Brg Cone - Flange Half	1	134297*†‡	134297*†	Replaces 129563 & 6082
<b>WHEEL DIFF CASE KITS</b>					
Includes items 12-14					
12	Diff Case-RH (Flg Half)	1			
	129464		508653	508724	Ratios 2.64 to 3.08
	133738 (was 129465)		508654	508725	Ratios 3.25 to 3.90
	133739 (was 129466)		508655	508726	Ratios 4.11 to 4.88
	133740 (was 129467)		508656	508727	Ratios 5.29 to 7.17
13	Diff Case-LH (Plain Half)-Standard	1	132437	---	Replaces 127498
	Diff Case-LH (Plain Half)-Diff Lock	1	---	128607	
14	Capscrew	12	127465	128619	
<b>WHEEL DIFF SIDE GEAR KIT</b>					
Includes items 15-19					
<b>WHEEL DIFF KIT w/o SIDE GEARS</b>					
Includes items 16-19					
15	Side Gear 41 Inv spline	2	127368	127368	
16	Side Gear Thrust Washer	2	127386*†	127386*	
17	Side Pinion Thrust Washer	4	129305*†	129305*	
18	Side Pinion	4	133784	133784	Replaces 129765
19	Diff Spider	1	129599	129599	
<b>RING GEAR NUT &amp; BOLT KIT</b>					
Includes items 20-21					
20	Nut	16	126216	126216	
21	Bolt	16	10010020	10010020	Replaces 128806 & 129686
22	Pinion Pilot Brg	1	10038915*†‡	10038915*†	Will replace 127484 in early 2018
23	Pinion Brg Cone - Inner	1	134291*†‡	134291*†	Replaces 129560
24	PINION BRG SPACER (SVC KIT)	AR	504043	504043	Individual pinion bearing spacers listed on page 9
25	Pinion Brg Cage & Cup Assy	1	134316	134316	Cage #127488C includes items 25-27, replaces 129767
	Cage #127488C NSS				
26	Pinion Brg Cup - Inner	1	134292*†‡	134292*†	Replaces 129561
27	Pinion Brg Cup - Outer	1	134295*†‡	134295*†	Replaces 012495
28	Pinion Brg Cone - Outer	1	134294*†‡	134294*†	Replaces 127535
29	Capscrew	6	210115	210115	
30	Pinion Helical Gear	1	127523	127523	
31	Roll Pin	1	118807	118807	
32	Slotted Pinion Nut	1	126182	126182	
33	Output Shaft O-Ring	2	127545*†	127545*	
34	Output Shaft Brg Cup	1	127536*†‡	127536*†	
35	Output Shaft Brg Cone	1	110812*†‡	110812*†	

NOTE 1: On June 3, 2002, the design of the carrier mounting flange changed. The new carriers are designed with a "Thick Flange". Carriers designed with a "Thick Flange" require the use of "long" capscrews. The fastening hardware for these models can be found on page 18 of this IPL. Refer to Dana bulletin ABIB-0210R1 for further details.

# Single Reduction-Forward Axles Before June 2008



Item	Description	Qty	DSH40(P) DSH44(P) DSP40(P) DSP41(P)	DDH40(P) DDH44(P) DDP40(P) DDP41(P)	Notes
<b>POWER DIVIDER SERVICE KITS</b>					
	<b>POWER DIVIDER KIT - MINOR BEFORE JUNE 2008</b>		504404-1	504404-1	Includes items 36, 38 & 39
	<b>POWER DIVIDER KIT - MAJOR BEFORE JUNE 2008</b>		504404-2	504404-2	Includes items 36, 38, 39, 41, 43 & 55
36	Output Shaft Side Gear	1	127645	127645	
37	Snap Ring	1	085997*‡	085997*	
38	Inter-Axle Diff Assy	1	134192	134192	Replaces 128634 & 129771
39	Helical Side Gear & Bushing Gear #130906 NSS	1	130907	130907	Replaces 127495 Includes Item 40
40	Bushing - Helical Gear	2	129371	129371	Replaces production #127543
41	Thrust Washer - Helical Gear	1	132439*‡	132439*	Replaces 128702
42	Lockout Sliding Clutch	1	127510	127510	
43	Input Shaft Kit shaft# 132447-NSS	1	504181	504181	Includes Items 43 & 55 Replaces 129770, 510394 & 510593
44	Oil Retainer	1	128700*	128700*	
45	Input Shaft Bearing Cone	1	134303*‡†	134303*†	Replaces 129558 & 820643
46	PDU Cover	1	130823	130823	See Note 46, replaces 129572
47	Washer	11	128415	128415	
48	Capscrew Long	11	210091	210091	See Note 46
49	Bearing Cup	1	134304*‡†	134304*†	Replaces 1008912
	<b>OIL SEAL &amp; SHIM KIT</b>	1	216224	216224	Includes shims & oil seals 127591 & 127592
	<b>PINION CAGE SHIM KIT</b>	1	504032	504032	Includes 5 each of the shims listed under #50
50	Shim.003"	AR	127595*‡	127595*	
	Shim.005"		127596*‡	127596*	
	Shim.010"		127597*‡	127597*	
	Shim.020"		127598*‡	127598*	
	Shim.030"		127599*‡	127599*	
51	Oil Seal-V-Ring	1	128703*‡†	128703*†	
52	Input Brg Cover Assy - #129574C		129575	129575	Includes item 49
53	Bearing Cover Cap Screw	6	210115	210115	
54	Oil Seal	1	127591*‡†	127591*†	
55	Locknut - Input	1	128049	128049	M42-1.5 (55mm socket)
56	Lube Trough	1	129577	129577	
	<b>SHIFT FORK &amp; COMPRESSION SPRING KIT</b>	1	510870	510870	Includes items 57-58
57	Shift Fork Assy - NSS	1	129856	129856	Order Kit 510870
58	Compression Spring	1	129859	129859	
59	Piston Cover Assy	1	129573	129573	Includes Cover #129578 & Item 60
60	O-Ring	1	129579	129579	
61	Piston	1	129580	129580	
62	O-Ring	1	210180	210180	
63	Shipping Plug	1	599792	599792	
64	Lube Pump Assembly	1	127534	127534	Pump Models Only
65	Capscrew	3	127551	127551	Pump Models Only
66	Drive Coupling - Service	1	128628	128628	Pump Models Only
67	Pipe Plug	5	090897	090897	Pump Models Only
68	Filter Screen Assy	1	127649	127649	Pump Models Only
69	Thrust Screw	1	126193	126193	M24 x 2-6g
70	Jam Nut	1	210184	210184	
71	RTV - Sealant	1	107276S*†	107276S*†	Not Illustrated

NSS - Not Sold Separately

*NOTE 46: On June 3, 2002, the design of the power divider cover changed. The original PDU covers (P/N: 129572) have 9 holes and require 9 fasteners. The current design PDU covers (P/N: 130823) have 11 holes and require the use of 11 long fasteners. The new 130823 PDU covers now replace the 129572 covers in service. The 9-hole PDU cover will NOT work on a carrier machined with 11 holes, use like PDU covers with like carriers.*

### SUMMARY OF KITS AND ASSEMBLIES

Air L/O Kit - Complete	510052	Includes items 57-59, 61- 62
Air L/O Repair Kit	510053	Includes items 59,61-62
Shift Fork & Compression Spring Kit	510870	Includes 57-58

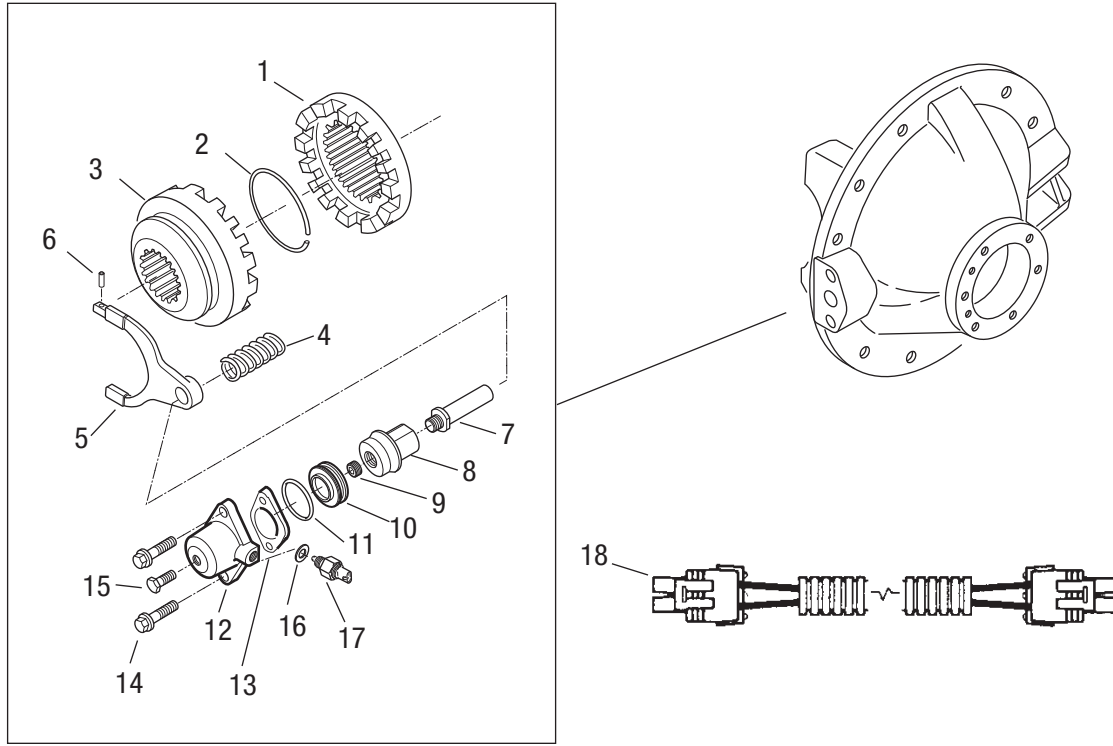

Item	Description	Qty	All Diff Lock Models	Notes
1	Fixed Curvic Clutch Gear	1	128627	
2	Snap Ring	1	129433	
3	SL Curvic Clutch Gear - 41 Inv spline	1	126840	
4	Compression Spring	1	128614	
<b>SHIFT FORK ASSY</b>			<b>217465</b>	<b>Includes items 5-6</b>
5	Shift Fork - 128611C NSS	1	—	128609 Fork – NSS
6	Spring Pin	1	210020	
7	Push Rod	1	132488	Replaces 128617
8	Piston Driver	1	132489	Replaces 128640
9	Set Screw	1	128618	M16x2
10	Piston	1	128624	
11	O-Ring	1	210180	
12	Piston Cover	1	129425	.250-18 thread airline opening
13	Gasket	1	128643	
14	Capscrew - Flg Head	2	128744	
15	Capscrew - Shipping	1	128274	M12 x 1.5 - used on old 129424 metric covers
	Capscrew - Shipping	1	129946	.250-18 threads
16	Washer	1	129034	
17	Switch	1	129035	
18	Wiring Harness	1	129047	



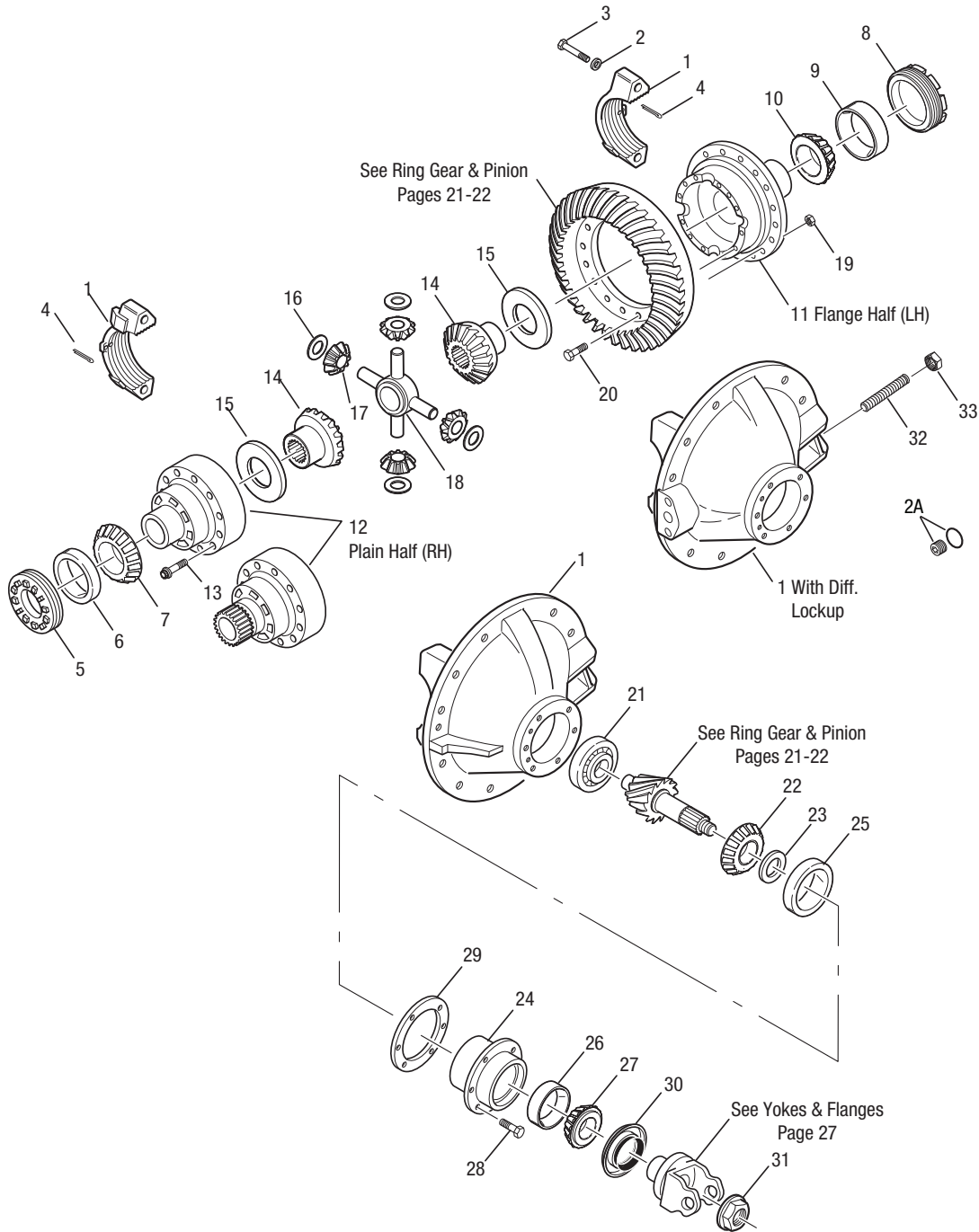

Item	Description	Qty	22060SH, 23060SH P20060, P22060 RSH40, RSH44 RSP40, RSP41	22060DH, 23060DH P20060, P22060D RDH40, RDH44 RDP40, RDP41	Notes
<b>BASIC OVERHAUL KIT</b>			510398	510400	Contents identified throughout chart below with *
<b>BEARING KIT</b>			512806	512805	Contents Identified throughout chart below with †
1	<b>DIFF CARR &amp; BRG CAPS KIT</b>				
	Includes 1-3, 32-34 and fasteners from 512087 page 18		510018	—	Casting # 130824
	See Note 1		—	510017	Casting # 130827
2	Flat Washer†	4	210288	210288	
2a	Plug & O-Ring Assembly	1	131809	131809	O-ring not sold separately
3	Capscrew	4	134481	134481	Replaces 210095
4	Cotter Pin	2	90873	90873	
5	Diff Brg Adjuster - Plain Half	1	129130	128616	
6	Bearing Cup - Plain Half	1	134301*†	134332*†	134301 replaces p/n 009803 & 129566. 134332 replaces 015092 see Dana bulletin # haxl-pni-33 <i>Brg pts must be used in mated sets</i>
7	Bearing Cone - Plain Half	1	134300*†	134331*†	134300 replaces p/n 027813 & 129565. 134331 replaces 128604 see Dana bulletin # haxl-pni-33 <i>Brg pts must be used in mated sets</i>
8	Diff Brg Adjuster - Flange Half	1	129128	129128	
9	Bearing Cup - Flange Half	1	134298*†	134298*†	Replaces 129564
10	Bearing Cone - Flange Half	1	134297*†	134297*†	Replaces 129563
<b>WHEEL DIFF CASE KITS</b>					Includes items 11-13
11	Diff Case-RH (Flg Half)	1			
	133737 (was 129464)		508653	508724	Ratios 2.64 to 3.08
	133738 (was 129465)		508654	508725	Ratios 3.25 to 3.90
	133739 (was 129466)		508655	508726	Ratios 4.11 to 4.88
	133740 (was 129467)		508656	508727	Ratios 5.29 to 7.17
12	Diff Case-LH (Plain Half)-Standard	1	132437	---	Replaces 127498
	Diff Case-LH (Plain Half)-Diff Lock	1	---	128607	
13	Capscrew	12	127465	128619	
<b>WHEEL DIFF SIDE GEAR KIT</b>			510397	510397	Includes items 14-18
<b>WHEEL DIFF KIT w/o SIDE GEARS</b>			510396	510396	Includes items 15-18
14	Side Gear 41 Inv spline	2	127368	127368	
15	Side Gear Thrust Washer	2	127386*	127386*	
16	Side Pinion Thrust Washer	4	129305*	129305*	
17	Side Pinion	4	129765	129765	
18	Diff Spider	1	129599	129599	
<b>RING GEAR NUT &amp; BOLT KIT</b>			508652	508652	Includes items 19-20
19	Nut	16	126216	126216	
20	Bolt	16	10010020	10010020	Replaces 129686
21	Pinion Pilot Brg	1	10038914*†	10038914*†	Will replace 127485 in early 2018
22	Pinion Brg Cone - Inner	1	134306*†	134306*†	Replaces 129562
23	<b>PINION BRG SPACER KIT</b>	1	504016	504016	Individual Pinion Brg Spacers Listed on page 9
24	Pinion Brg Cage & Cup Assy	1			Includes items 24-26
	Cage #127481C NSS		10002988	10002988	Standard Design, replaces 129768 & 134353
	Cage #129995C NSS		10003017	10003017	Parking Brake Design Replaces 129996
25	Pinion Brg Cup - Inner	1	134292*†	134292*†	Replaces 129561
26	Pinion Brg Cup - Outer	1	134295*†	134295*†	Replaces 012495
27	Pinion Brg Cone - Outer	1	134308*†	134308*†	Replaces 012496
28	Capscrew	6	210115	210115	
<b>OIL SEAL &amp; SHIM KIT</b>			216225	216225	Includes items 29-30, 34
<b>PINION CAGE SHIM KIT</b>			504032	504032	Includes 5 each of the shims listed below
29	Shim.003	AR	127595*	127595*	
	Shim.005		127596*	127596*	
	Shim.010		127597*	127597*	
	Shim.020		127598*	127598*	
	Shim.030		127599*	127599*	
30	Oil Seal	1	127591*†	127591*†	
31	Pinion Nut	1	127589	127589	M36 x 1.5 (55mm socket)
32	Thrust Screw	1	126193	126193	M24 x 2-6g
33	Jam Nut	1	210184	210184	
34	RTV Sealant 3 oz	1	107276S*†	107276S*†	Not Illustrated

NSS - Not Sold Separately

NOTE 1: On June 3, 2002, the design of the carrier mounting flange changed. The new carriers are designed with a "Thick Flange." Carriers designed with a "Thick Flange" require the use of "long" capscrews. The fastening hardware for these models can be found on page 18 of this IPL. Refer to Dana bulletin ABIB-0210R1 for further details.

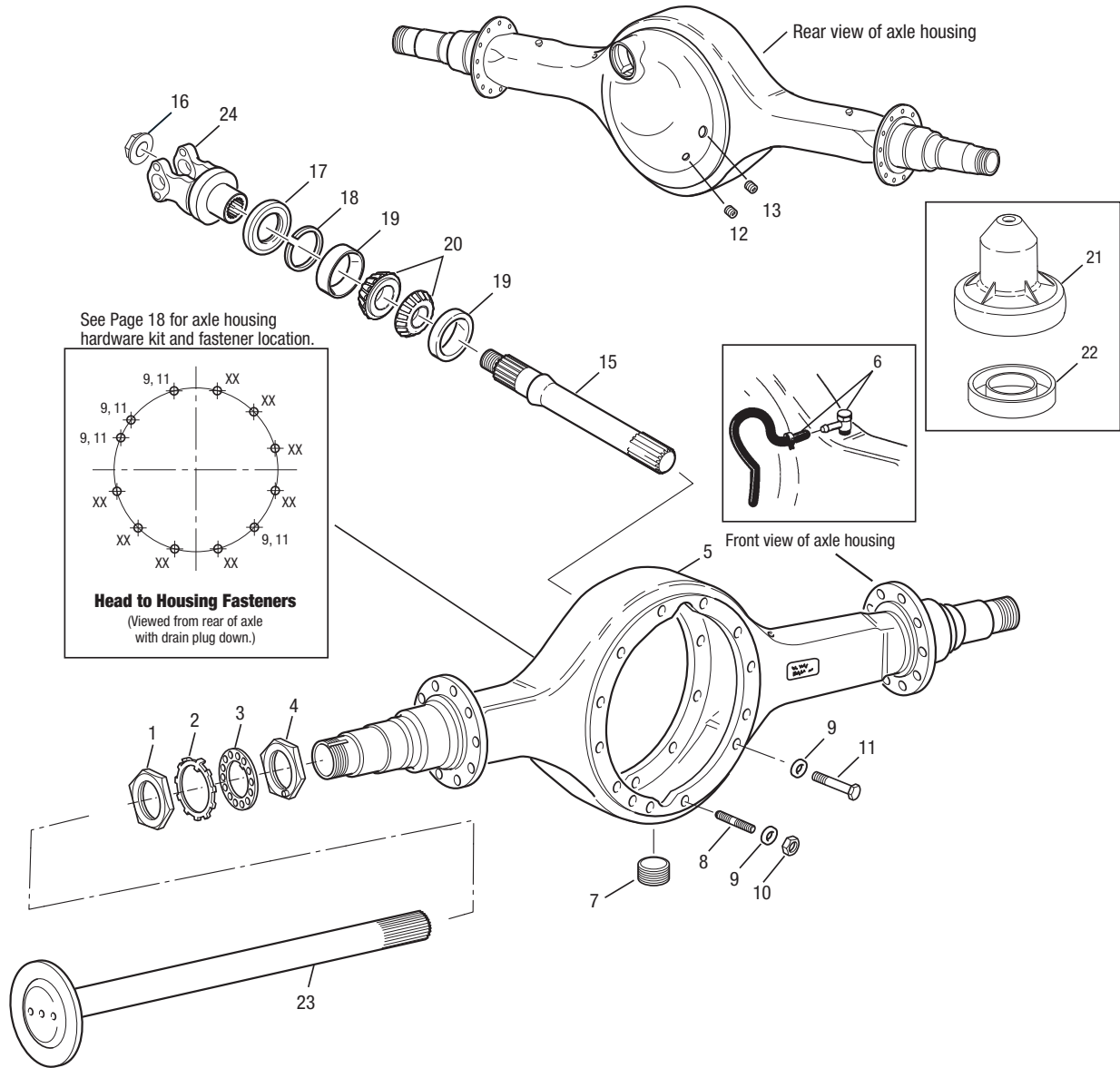

Item	Description	Qty	Part #	Notes
<b>SPINDLE NUT KIT</b>		<b>1</b>	<b>504158</b>	<b>Includes 1 each of Items 1-4</b>
1	Outer Bearing Adjuster Nut	2	119881	
2	Lockwasher - w/ Tab	2	129132	
3	Dowel-Type Lockwasher	2	119883	
4	Inner Bearing Adjuster Nut	2	119882	
5	Axle Housing Assy	1		See your OEM Catalog
<b>6 BREATHER KIT</b>			<b>507162</b>	
7	Magnetic Drain Plug - 3/4"	1	054254	All D/R models
<b>AXLE HOUSING HARDWARE KIT</b>		<b>1</b>	<b>512087</b>	<b>D/R Models -Thick Flange</b>
<b>AXLE HOUSING HARDWARE KIT</b>		<b>1</b>	<b>511600</b>	<b>D/R Models -Thin Flange</b>
<b>AXLE HOUSING HARDWARE KIT</b>		<b>1</b>	<b>514260</b>	<b>23060SH, 23060DH Models</b>
8	Stud	AR	127641	Varies by application & model see pg 18
9	Washer	AR	130877	Varies by application & model see pg 18
10	Nut	AR	127567	Varies by application & model see pg 18
11	Capscrew - Long	AR	130837	Varies by application & model see pg 18
11	Capscrew - Short	AR	130836	Varies by application & model see pg 18
12	Non-Magnetic Plug 3/4"	1	129492	
12	Magnetic Plug - 3/4"	1	129491	
13	Temperature Sensor Plug 1/2"	1	090898	
14	Lube Tag (for 3/4" Plug)	1	129486	Not Illustrated
<b>OUTPUT SHAFT KIT</b>		<b>1</b>	<b>216227</b>	<b>Includes items 15-16</b>
15	Output Shaft - #127646 NSS			
16	Locknut - Hex	1	127588	M39 x 1.5 (55mm socket)
17	Oil Seal	1	127592*†	
18	Snap Ring .103"	1	129594*†	
19	Bearing Cup	2	127539*†	
20	Bearing Cone	2	127540	
21	Seal Driver	1	126917	In Kit 217414 - See Page 28
22	Adapter	1	128706	In Kit 217414 - See Page 28
23	Axle Shaft	2		See Axle Shaft Chart Pg 20
24	Yoke and Slinger Assy	1		See Yoke and Flange Chart Pg 27
25	Loctite Adhesive	1	129293	Not Illustrated, .5 ml Tube
26	RTV Sealant	1	107276S	Not Illustrated, 3 oz. Tube

*NSS - Not Sold Separately*

\* Included in basic overhaul kits - forward models

† Included in bearing kits - forward models

Beginning June 3rd, 2002, the nominal thickness of the carrier to housing flange was increased in the DSP40/DSH40/DSH44 Forward & Rear-Rear family of carriers. This change required the use of new fastener parts. A new (45mm) capscrew (Part # 130836) was released as it replaced both 210173 and 130158 old design capscrews. Additionally, a much thicker boss was added to the flange at the 12 & 6 o'clock positions. These new, thicker flange boss carriers require an even longer (70mm) capscrew (Part #130837). A thicker and larger diameter flat washer (Part #130877) was also released as part of this upgrade. The 130877 washer replaces washer 029804. The existing stud (Part #127641) and nut (Part #127567) were not affected by these changes and continue to be used.

### SERVICE CARRIER NOTE:

With the popularity of Dana carriers inventory of both early design carriers and new "Thick Flange" design carriers exist. If you have a vehicle that was originally equipped with a Dana axle built with the "Thick Flange" carrier design, it can be universally serviced with an early style (Thin Flange) carrier unit. The repairing dealer must simply make sure to use the correct axle housing hardware parts when the installation is done. New carriers built with the thick flange design will include the necessary thick flange hardware kit to minimize any down time to the customer.

- Differentials with "THICK FLANGE" carriers use axle housing hardware kit (Part # 512087)
- Early design differentials with "THIN FLANGE" carriers use axle housing hardware kit (Part # 511600)

## New Axle Housing Fasteners

### IMPORTANT!

Dana does not recommend the mixing of various designs carrier-to housing capscrews on the same assembly. Whether mixing or not, torques must be measured using a calibrated torque wrench. Failure to re-torque bolts and nuts to proper specifications may lead to carrier to housing leaks and possible component damage.

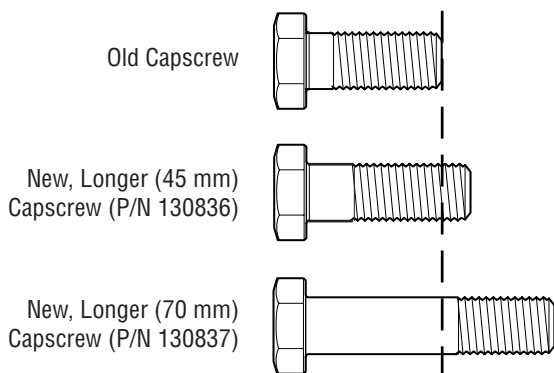
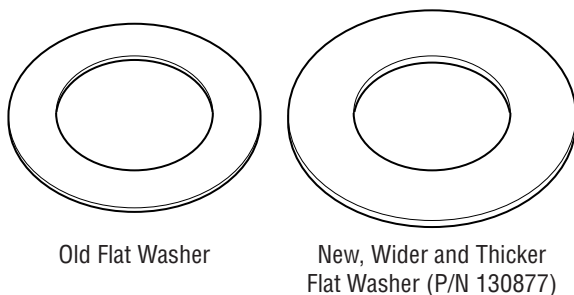

## Axle Housing Fastener Kits

On June 3, 2002 the DSP/RSP40, DSH/RSH40 and DSH/RSH44 family models were upgraded to the new "Thick Flange" carrier design as fully detailed in Dana bulletin ABIB-0210R1. Shown below are the axle housing hardware kits and fastener locations for both variations. View fastener locations as if installing differential into the axle housing.

512087 Hardware Kit (Thick Flange)		
Part #	Qty.	Description
107276S	1	RTV Sealant 3 oz. Tube
127567	4	Nut
127641	4	Stud
129293	1	Loctite 271 0.5 ml. Tube
130836	8	Capscrew (45 mm) - Short
130837	4	Capscrew (70 mm) - Long
130877	12	Washer
shais136	1	Instruction Sheet - Thick Flange

511600 Hardware Kit (Thin Flange)		
Part #	Qty.	Description
107276S	1	RTV Sealant 3 oz. Tube
127567	4	Nut
127641	4	Stud
129293	1	Loctite 271 0.5 ml. Tube
130836	10	Capscrew (was 130158)
130877	12	Washer (was 029804)
shais131	1	Instruction Sheet

514240 Hardware Kit (23060SH models)		
Part #	Qty.	Description
054254	1	Plug - Drain 3/4"
129491	1	Plug - Magnetic 3/4"
130836	8	Capscrew (45 mm) - Short
130837	4	Capscrew (70 mm) - Long
130877	12	Washer
107276S	1	RTV Sealant 3 oz. Tube
shais131	1	Instruction Sheet

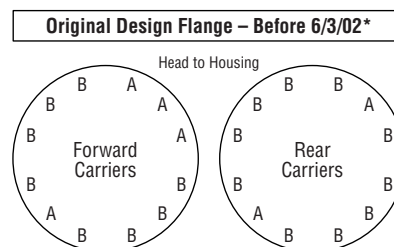
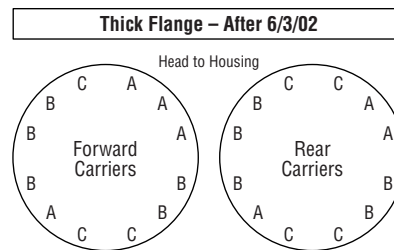

A – 127641 Studs & 127567 Nuts  
 B – 130836 Capscrews – Short (45 mm)  
 C – 130837 Capscrews – Long (70 mm)  
 D – 130877 Flat Washers – All Locations

**Axle Shafts - All Models**

Dana Spicer axle shafts are used in “sets,” have unequal shaft lengths and may be “location specific” or “wheel equipment specific.” When replacing axle shafts, locate the axle shaft part number (see **Model Identification** in front of IPL), or select the correct axle shaft from the chart below before placing your order.

**DO NOT MISPLACE AXLE SHAFTS FROM THEIR INTENDED LOCATION.**

Axle Shafts - Single Reduction Models							
Part #	Qty	Body Spline	Shaft O.D.	Spline Length	Flange Length	Flange O.D.	Holes
127437	1	41	1.87	38.976	4"	8.500	8 (0.635) STR
127438	1	41	1.87	43.307	4"	8.500	8 (0.635) STR
128514	1	41	1.87	38.130	4"	8.500	8 (0.773) STR
128515	1	41	1.87	42.460	4"	8.500	8 (0.773) STR
128516	1	41	1.87	38.976	4"	8.500	8 (0.948) TPR
128517HX	1	41	1.87	43.307	4"	8.500	8 (0.948) TPR
128521HX	1	41	1.87	38.130	4"	8.500	8 (0.948) TPR
128522HX	1	41	1.87	42.460	4"	8.500	8 (0.948) TPR

Axle Shafts - Diff Lock Models							
Part #	Qty	Body Spline	Shaft O.D.	Spline Length	Flange Length	Flange O.D.	Holes
127437	1	41	1.87	38.976	4"	8.500	8 (0.635) STR
128435	1	41	1.87	43.307	11"	8.500	8 (0.635) STR
128514	1	41	1.87	38.130	4"	8.500	8 (0.773) STR
128559	1	41	1.87	42.460	11"	8.500	8 (0.773) STR
128516	1	41	1.87	38.976	4"	8.500	8 (0.948) TPR
128561HX	1	41	1.87	43.307	11"	8.500	8 (0.948) TPR
128521HX	1	41	1.87	38.130	4"	8.500	8 (0.948) TPR
128563-NLA	1	41	1.87	42.460	11"	8.500	8 (0.948) TPR
128910	1	41	1.87	42.460	4"	8.500	8 (0.635) STR
128504	1	41	1.87	46.156	11"	8.500	8 (0.635) STR

*Note: STR - Straight, TPR - Tapered*

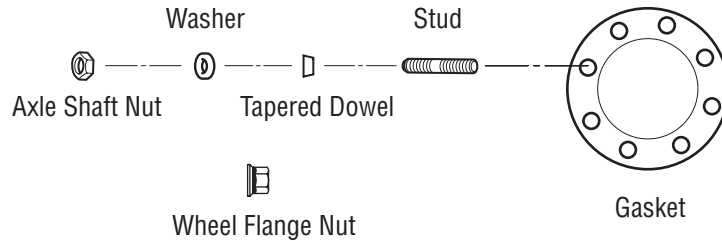

Axle Shaft Hardware					
Part #	Description	Dim. A	Dim. B	Dim. C	Notes
013885	Tapered Dowel	1.00"	0.630"	0.469	For 5/8" studs - Split Dowel Design
132993	Tapered Dowel	1.00"	0.630"	0.469"	For 5/8" studs
013886	Gasket	8 hole			
029804	Washer				
060600	Axle Shaft Nut	5/8"	18 thread		
127794	Stud - Wheel	5/8"	18 thread		

Dana has highly developed primary axle gearing which is only used in matched sets. These sets are identified by the mating parts listed below. Within any Dana production drive axle or genuine Spicer® Gear & Pinion service kits, these mated part numbers will appear. Because they are developed as a set with precision machining, never mix gears and pinions from different mated sets within an axle. Shortened gearing life, noise and failure may occur. Always use genuine Spicer® products.

## D - Forward Axles

**DDP40, DDP41, DSP40, DSP41**  
**15.40" - 15.65" HYPOID**  
**PINION NUT PART #126182**

Ratio	Spicer Kit	Mated Gear/Pinion Set 3-axis		Mated Gear/Pinion Set 2-axis		Tooth Combo	Ring Gear Size (in.)	Set Part #
		Gear(NSS)	Pinion(NSS)	Gear(NSS)	Pinion(NSS)			
2.64	211462	134020	134021	127387	127439	37/14	14.90	211428
2.85	211463	-----	-----	127388	127440	37/13	15.40	211429
2.93	509423	134194	134198	129532	129531	41/14	15.40	509421
3.08	513386	134182	134181	127388	129716	37/12	15.40	511272
3.25	513385	134066	134067	127389	130120	39/12	15.40	511273
3.36	513384	132234	132304	127388	130121	37/11	15.40	132292
3.42	504056	134327	134328	-----	-----	41/12	15.40	134330
3.55	513383	132236	132305	127389	130122	39/11	15.40	132268
3.70	513382	132238	132207	127388	130123	37/10	15.40	132270
3.90	513381	132240	132209	127389	130124	39/10	15.40	132272
4.11	513380	132242	132211	127388	130125	37/9	15.40	132274
4.33	513379	134056	134057	130201	130126	39/9	15.40	511279
4.63	513378	134005	134002	130196	129733	37/8	15.65	511280
4.88	513377	132248	132217	130197	129735	39/8	15.65	511281
5.29	513376	134006	134003	130196	129816	37/7	15.65	511282
5.57	513375	134007	134004	130197	129820	39/7	15.65	511283
6.17	513374	134016	134018	127390	129843	37/6	15.65	511284
6.50	511571	134017	134019	130204	127454	39/6	15.65	511553
7.17	511572	-----	-----	130178	130177	43/6	15.65	511554

NSS – Not Sold Separately

## R - Rear Axle

**P20060S/D, P22060S/D, RSP/RDP40, RSP/RDP41**  
**39-1.95" INV SPLINE: 15.4" - 15.65" HYPOID**  
**PINION NUT PART #127589**

Ratio	Spicer Kit	Mated Gear/Pinion Set 3-axis		Mated Gear/Pinion Set 2-axis		Tooth Combo	Ring Gear Size (in.)	Set Part #
		Gear(NSS)	Pinion(NSS)	Gear(NSS)	Pinion(NSS)			
2.64	211478	134022	134023	127380	127420	37/14	14.90	211444
2.85	211479	-----	-----	127381	127421	37/10	15.40	211445
2.93	509424	-----	-----	129534	129533	41/14	15.40	509422
3.08	513373	132115	132072	127381	129737	37/12	15.40	132150
3.25	513372	134068	134069	127382	130127	39/12	15.40	511286
3.36	513371	132119	132076	127381	130128	37/11	15.40	132155
3.42	504055	134325	134326	-----	-----	41/12	15.40	134329
3.55	513370	132121	132080	127382	130129	39/11	15.40	132159
3.70	513369	132123	132083	127381	130130	37/10	15.40	132162
3.90	513368	132125	132086	127382	130131	39/10	15.40	132165
4.11	513367	132127	132089	127381	130132	37/9	15.40	132168
4.33	513366	132130	132094	130200	130133	39/9	15.40	132173
4.63	513365	132132	132097	130194	129748	37/8	15.65	132176
4.88	513364	132135	132101	130195	129750	39/8	15.65	132181
5.29	513363	132137	132104	130194	129818	37/7	15.65	132185
5.57	513362	132139	132107	130195	129822	39/7	15.65	132189
6.17	513361	132141	132109	127383	129844	37/6	15.65	132192
6.50	211493	132143	132110	127384	127435	39/6	15.65	132194
7.17	211494	132145	132111	127385	127436	43/6	15.65	132196

NSS – Not Sold Separately

## D - Forward Axle

**DDH40, DDH44, DSH40, DSH44**  
**15.75" HYPOID**  
**PINION NUT PART #126182**

Ratio	Spicer Kit	Mated Gear/Pinion Set 3-axis		Mated Gear/Pinion Set 2-axis		Tooth Combo	Ring Gear Size (in.)	Set Part #
		Gear(NSS)	Pinion(NSS)	Gear(NSS)	Pinion(NSS)			
3.25	510105	129721	129719	-----	-----	39/12	15.75	510085
3.36	510106	129723	129722	-----	-----	37/11	15.75	510086
3.55	510107	129721	129725	-----	-----	39/11	15.75	510087
3.70	510108	129723	129727	-----	-----	37/10	15.75	510088
3.90	510109	129721	129729	-----	-----	39/10	15.75	510089
4.11	510110	129723	129730	-----	-----	37/9	15.75	510090
4.33	510111	129721	129732	-----	-----	39/9	15.75	510091
<b>These Original Gear Set Kits listed below are no longer available - they are now replaced by DSP40 Gearing and are listed for identification purposes only</b>								
3.08	510104-NLA r/b 513386			129717	129716	37/8	15.40	510084
4.63	510112-NLA r/b 513376			129734	129733	37/8	15.65	510092
4.88	510113-NLA r/b 513377			129736	129735	39/8	15.65	510093
5.29	511894-NLA r/b 513376			129734	129816	37/7	15.65	510263
5.57	512147-NLA r/b 513375			129736	129820	39/7	15.65	510265
6.17	510462-NLA r/b 513374			129734	129843	37/6	15.65	510458

*NSS – Not Sold Separately*

## R - Rear Axle

**22060DH, 22060SH, 23060DH, 23060SH, RDH40, RDH44, RSH40, RSH44**  
**39-1.95" INV SPLINE: 15.75" HYPOID**  
**PINION NUT PART #127589**

Ratio	Spicer Kit	Mated Gear/Pinion Set 3-axis		Mated Gear/Pinion Set 2-axis		Tooth Combo	Ring Gear Size (in.)	Set Part #
		Gear(NSS)	Pinion(NSS)	Gear(NSS)	Pinion(NSS)			
3.25	510115	129740	129739	-----	-----	39/12	15.75	510095
3.36	510116	129742	129741	-----	-----	37/11	15.75	510096
3.55	510117	129740	129743	-----	-----	39/11	15.75	510097
3.70	510118	129742	129744	-----	-----	37/10	15.75	510098
3.90	510119	129740	129747	-----	-----	39/10	15.75	510099
4.11	510120	129742	129746	-----	-----	37/9	15.75	510100
4.33	510121	129740	129747	-----	-----	39/9	15.75	510101
<b>These Original Gear Set Kits listed below are no longer available - they are now replaced by RSP40 Gearing and are listed for identification purposes only.</b>								
3.08	510114-NLA r/b 513373			129738	129737	37/12	15.40	510094
4.63	510122-NLA r/b 513365			129749	129748	37/8	15.65	510102
4.88	510123-NLA r/b 513364			129751	129750	39/8	15.65	510103
5.29	511518-NLA r/b 513363			129749	129818	37/7	15.65	510264
5.57	511519-NLA r/b 513362			129751	129822	39/7	15.65	510266
6.17	510463-NLA r/b 513361			129749	129844	37/6	15.65	510459
6.50	511573-NLA r/b 211493			130206	127435	39/6	15.65	132194

*NSS – Not Sold Separately*



## DSP40 - PREMIUM 40 CARRIER

Spline: 41 Involute  
 Gearing: 15.50" - 15.65" Hypoid  
 Side Gear Part Number: 127368  
 Fastener Kit: 512087

These new carrier units will directly replace model DSP40, DSP41 and \*DSH44 with no modifications. See Note 1 for information on DSH44 models in ratios 5.29 thru 7.17.

Ratio	New Carrier Exchange	New Carrier Core Free	Old Carrier Part - NLA	Notes
2.64	DSP40264EX	DSP40264CF	682965	
2.85	DSP40285EX	DSP40285CF	681529	
2.93	DSP40293EX	DSP40293CF	682966	
3.08	DSP40308EX	DSP40308CF	682967	
3.25	DSP40325EX	DSP40325CF	682968	
3.36	DSP40336EX	DSP40336CF	682969	
3.42	DSP40342EX	DSP40342CF	681535	
3.55	DSP40355EX	DSP40355CF	682970	
3.70	DSP40370EX	DSP40370CF	682971	
3.90	DSP40390EX	DSP40390CF	682972	
4.11	DSP40411EX	DSP40411CF	682973	
4.33	DSP40433EX	DSP40433CF	682974	
4.63	DSP40463EX	DSP40463CF	682975	
4.88	DSP40488EX	DSP40488CF	682976	
5.29	DSP40529EX	DSP40529CF	682977	
5.57	DSP40557EX	DSP40557CF	682978	
6.17	DSP40617EX	DSP40617CF	682979	
6.50	DSP40650EX	DSP40650CF	682980	
7.17	DSP40717EX	DSP40717CF	682014	

Note 1: The DSH44 carriers in ratios 5.29 thru 7.17 are now replaced by DSP40 service carriers. Refer to Dana bulletin abib-0902.

## DSP40P - PREMIUM 40 CARRIER W/ PUMP OPTION

Spline: 41 Involute  
 Gearing: 15.50" - 15.65" Hypoid  
 Side Gear Part Number: 127368  
 Fastener Kit: 512087 for thick flange carriers & 511600 for thin flange carriers

These new carrier units will directly replace model DSP40P, DSP41P and \*DSH44P with no modifications. See Note 1 for information on DSH44P models in ratios 5.29 thru 7.17.

Ratio	New Carrier Exchange	New Carrier Core Free	Old Carrier Part - NLA	Notes
2.64	DSP40P264EX	DSP40P264CF	682997	
2.85	DSP40P285EX	DSP40P285CF	681530	
2.93	DSP40P293EX	DSP40P293CF	682998	
3.08	DSP40P308EX	DSP40P308CF	682999	
3.25	DSP40P325EX	DSP40P325CF	682000	
3.36	DSP40P336EX	DSP40P336CF	682001	
3.42	DSP40P342EX	DSP40P342CF	681536	
3.55	DSP40P355EX	DSP40P355CF	682002	
3.70	DSP40P370EX	DSP40P370CF	682003	
3.90	DSP40P390EX	DSP40P390CF	682004	
4.11	DSP40P411EX	DSP40P411CF	682005	
4.33	DSP40P433EX	DSP40P433CF	682006	
4.63	DSP40P463EX	DSP40P463CF	682007	
4.88	DSP40P488EX	DSP40P488CF	682008	
5.29	DSP40P529EX	DSP40P529CF	682009	Note 1
5.57	DSP40P557EX	DSP40P557CF	682010	Note 1
6.17	DSP40P617EX	DSP40P617CF	682011	Note 1
6.50	DSP40P650EX	DSP40P650CF	682012	Note 1
7.17	DSP40P717EX	DSP40P717CF	682013	Note 1

Note 1: The DSH44P carriers in ratios 5.29 thru 7.17 are now replaced by DSP40P service carriers.

## RSP40 - PREMIUM 40 CARRIER

Spline: 41 Involute  
 Gearing: 15.50" - 15.65" Hypoid  
 Side Gear Part Number: 127368  
 Fastener Kit: 512087

These new carrier units will directly replace rear tandem models RSP40, RSP41, RSH44\* and single axle models P20060S, P21060S and P22060S with no modifications. See Note 1 for information on RSH44 models in ratios 5.29 thru 7.17.

Ratio	New Carrier Exchange	New Carrier Core Free	Old Carrier Part - NLA	Notes
2.64	RSP40264EX	RSP40264CF	676029	
2.85	RSP40285EX	RSP40285CF	681531	
2.93	RSP40293EX	RSP40293CF	676030	
3.08	RSP40308EX	RSP40308CF	676031	
3.25	RSP40325EX	RSP40325CF	676032	
3.36	RSP40336EX	RSP40336CF	676033	
3.42	RSP40342EX	RSP40342CF	681537	
3.55	RSP40355EX	RSP40355CF	676034	
3.70	RSP40370EX	RSP40370CF	676035	
3.90	RSP40390EX	RSP40390CF	676036	
4.11	RSP40411EX	RSP40411CF	676037	
4.33	RSP40433EX	RSP40433CF	676038	
4.63	RSP40463EX	RSP40463CF	676039	
4.88	RSP40488EX	RSP40488CF	676040	
5.29	RSP40529EX	RSP40529CF	676041	Note 1
5.57	RSP40557EX	RSP40557CF	676042	Note 1
6.17	RSP40617EX	RSP40617CF	676043	Note 1
6.50	RSP40650EX	RSP40650CF	676044	Note 1
7.17	RSP40717EX	RSP40717CF	681443	Note 1

Note 1: The RSH44 carriers in ratios 5.29 thru 7.17 are now replaced by RSP40 service carriers.

## P20060R - PREMIUM 40 RETARDER READY CARRIER

Spline: 41 Involute  
 Gearing: 15.50" - 15.65" Hypoid  
 Side Gear Part Number: 127368  
 Fastener Kit: N/A

Ratio	New Carrier Exchange	New Carrier Core Free	Old Carrier Part - NLA	Notes
3.08	P20060R308EX	P20060R308CF	681514	
3.25	P20060R325EX	P20060R325CF	681515	
3.36	P20060R336EX	P20060R336CF	681516	
3.55	P20060R355EX	P20060R355CF	681517	
3.70	P20060R370EX	P20060R370CF	681518	
3.90	P20060R390EX	P20060R390CF	681519	
4.11	P20060R411EX	P20060R411CF	681520	
4.33	P20060R433EX	P20060R433CF	681521	
4.63	P20060R463EX	P20060R463CF	681522	
4.88	P20060R488EX	P20060R488CF	681523	
5.29	P20060R529EX	P20060R529CF	681524	
5.57	P20060R557EX	P20060R557CF	681525	
6.17	P20060R617EX	P20060R617CF	681526	
6.50	P20060R650EX	P20060R650CF	681527	

**DDP40 PREMIUM 40 - DIFF LOCK CARRIER**

Spline: 41 Involute  
 Gearing: 15.50" - 15.75" Hypoid  
 Side Gear Part Number: 127368  
 Fastener Kit: 512087

*These new carrier units will directly replace model DDP40 and DDP41 with no modifications. See Note 1 for information on DDH44 models in ratios 5.29 thru 7.17.*

Ratio	New Carrier Exchange	New Carrier Core Free	Old Carrier Part - NLA	Notes
2.64	DDP40264EX	DDP40264CF	682949	
2.85	DDP40285EX	DDP40285CF	681532	
2.93	DDP40293EX	DDP40293CF	682950	
3.08	DDP40308EX	DDP40308CF	682951	
3.25	DDP40325EX	DDP40325CF	682952	
3.36	DDP40336EX	DDP40336CF	682953	
3.42	DDP40342EX	DDP40342CF	681538	
3.55	DDP40355EX	DDP40355CF	682954	
3.70	DDP40370EX	DDP40370CF	682955	
3.90	DDP40390EX	DDP40390CF	682956	
4.11	DDP40411EX	DDP40411CF	682957	
4.33	DDP40433EX	DDP40433CF	682958	
4.63	DDP40463EX	DDP40463CF	682959	
4.88	DDP40488EX	DDP40488CF	682960	
5.29	DDP40529EX	DDP40529CF	682961	Note 1
5.57	DDP40557EX	DDP40557CF	682962	Note 1
6.17	DDP40617EX	DDP40617CF	682963	Note 1
6.50	DDP40650EX	DDP40650CF	682964	Note 1
7.17	DDP40717EX	DDP40717CF	682015	Note 1

*Note 1: The DDH44 carriers in ratios 5.29 thru 7.17 now replaced by DSP40 service carriers. Refer to Dana bulletin abib-0902.*

**DDP40P PREMIUM 40 - DIFF LOCK CARRIER W/ PUMP OPTION**

Spline: 41 Involute  
 Gearing: 15.50" - 15.75" Hypoid  
 Side Gear Part Number: 127368  
 Fastener Kit: 512087

*These new carrier units will directly replace model DDP40P and DDP41P with no modifications. See Note 1 for information on DDH44P models in ratios 5.29 thru 7.17.*

Ratio	New Carrier Exchange	New Carrier Core Free	Old Carrier Part - NLA	Notes
2.64	DDP40P264EX	DDP40P264CF	682981	
2.85	DDP40P285EX	DDP40P285CF	681533	
2.93	DDP40P293EX	DDP40P293CF	682982	
3.08	DDP40P308EX	DDP40P308CF	682983/682770	
3.25	DDP40P325EX	DDP40P325CF	682984	
3.36	DDP40P336EX	DDP40P336CF	682985	
3.42	DDP40P342EX	DDP40P342CF	681539	
3.55	DDP40P355EX	DDP40P355CF	682986	
3.70	DDP40P370EX	DDP40P370CF	682987	
3.90	DDP40P390EX	DDP40P390CF	682988	
4.11	DDP40P411EX	DDP40P411CF	682989	
4.33	DDP40P433EX	DDP40P433CF	682990	
4.63	DDP40P463EX	DDP40P463CF	682991	
4.88	DDP40P488EX	DDP40P488CF	682992	
5.29	DDP40P529EX	DDP40P529CF	682993	Note 1
5.57	DDP40P557EX	DDP40P557CF	682994	Note 1
6.17	DDP40P617EX	DDP40P617CF	682995	Note 1
6.50	DDP40P650EX	DDP40P650CF	682996	Note 1
7.17	DDP40P717EX	DDP40P717CF	682016	Note 1

*Note 1: The DDH44P carriers in ratios 5.29 thru 7.17 now replaced by DSP40P service carriers. Refer to Dana bulletin abib-0902.*

**RDP40 - PREMIUM 40 - DIFF LOCK CARRIER**

Spline: 41 Involute  
 Gearing: 15.50" - 15.65" Hypoid  
 Side Gear Part Number: 127368

Fastener Kit: 512087 for thick flange carriers & 511600 for thin flange carriers  
*These new carrier units will directly replace rear tandem models RDP40, RDP41 & RDH44\* and single axle model P20060D, P21060D and P22060D with no modifications. See Note 1 for information on RDH44 models in ratios 5.29 thru 7.17.*

Ratio	New Carrier Exchange	New Carrier Core Free	Old Carrier Part - NLA	Notes
2.64	RDP40264EX	RDP40264CF	676013	
2.85	RDP40285EX	RDP40285CF	681534	
2.93	RDP40293EX	RDP40293CF	676014	
3.08	RDP40308EX	RDP40308CF	676015	
3.25	RDP40325EX	RDP40325CF	676016	
3.36	RDP40336EX	RDP40336CF	676017	
3.42	RDP40342EX	RDP40342CF	681540	
3.55	RDP40355EX	RDP40355CF	676018	
3.70	RDP40370EX	RDP40370CF	676019	
3.90	RDP40390EX	RDP40390CF	676020	
4.11	RDP40411EX	RDP40411CF	676021	
4.33	RDP40433EX	RDP40433CF	676022	
4.63	RDP40463EX	RDP40463CF	676023	
4.88	RDP40488EX	RDP40488CF	676024	
5.29	RDP40529EX	RDP40529CF	676025	Note 1
5.57	RDP40557EX	RDP40557CF	676026	Note 1
6.17	RDP40617EX	RDP40617CF	676027	Note 1
6.50	RDP40650EX	RDP40650CF	676028	Note 1
7.17	RDP40717EX	RDP40717CF	681444	Note 1

*Note 1: The RDH44 carriers in ratios 5.29 thru 7.17 now replaced by RDP40 service carriers. For specific part number supersession refer to Dana bulletin abib-0902.*

**P20060DR - PREMIUM 40 - W/ DIFF LOCK OPTION & RETARDER READY**

Spline: 41 Involute  
 Gearing: 15.50" - 15.65" Hypoid  
 Side Gear Part Number: 127368  
 Fastener Kit: N/A

Ratio	New Carrier Exchange	New Carrier Core Free	Old Carrier Part - NLA	Notes
3.08	P20060DR308EX	P20060DR308CF	681463	
3.25	P20060DR325EX	P20060DR325CF	681464	
3.36	P20060DR336EX	P20060DR336CF	681465	
3.55	P20060DR355EX	P20060DR355CF	681466	
3.70	P20060DR370EX	P20060DR370CF	681467	
3.90	P20060DR390EX	P20060DR390CF	681468	
4.11	P20060DR411EX	P20060DR411CF	681469	
4.33	P20060DR433EX	P20060DR433CF	681470	
4.63	P20060DR463EX	P20060DR463CF	681471	
4.88	P20060DR488EX	P20060DR488CF	681472	
5.29	P20060DR529EX	P20060DR529CF	681473	
5.57	P20060DR557EX	P20060DR557CF	681474	
6.17	P20060DR617EX	P20060DR617CF	681475	
6.50	P20060DR650EX	P20060DR650CF	681476	
7.17	P20060DR717EX	P20060DR717CF	681477	

## DSH40 - HIGH PERFORMANCE CARRIER

Spline: 41 Involute  
 Gearing: 15.75" Hypoid  
 Side Gear Part Number: 127368  
 Fastener Kit: 512087

*These new carrier units will directly replace models DSH40 and DS454 with no modifications. See Note 1.*

Ratio	New Carrier Exchange	New Carrier Core Free	Old Carrier Part - NLA	Notes
3.25	DSH40325EX	DSH40325CF	682741	
3.36	DSH40336EX	DSH40336CF	682742	
3.55	DSH40355EX	DSH40355CF	682743	
3.70	DSH40370EX	DSH40370CF	682744	
3.90	DSH40390EX	DSH40390CF	682745	
4.11	DSH40411EX	DSH40411CF	682746	
4.33	DSH40433EX	DSH40433CF	682747	

*Note 1: The D/R454 family of axles were originally replaced by tandem models: DSH40/RSH40 or DSH44/RSH44 depending on select ratios. The carriers and ratios above are the High Performance, Large Ring Gear service carriers. For all other ratios not shown are now directly serviced by the DSP/RSP40 models, refer to those carrier listings and also see Dana bulletin abib-0902.*

## RSH40 - HIGH PERFORMANCE CARRIER

Spline: 41 Involute  
 Gearing: 15.75" Hypoid  
 Side Gear Part Number: 127368  
 Fastener Kit: 512087

*These new carrier units will directly replace model RSH40, RSH44, 22060SH, 23060SH and RS454 with no modifications. See Note 1.*

Ratio	New Carrier Exchange	New Carrier Core Free	Old Carrier Part - NLA	Notes
3.25	RSH40325EX	RSH40325CF	675781	
3.36	RSH40336EX	RSH40336CF	675782	
3.55	RSH40355EX	RSH40355CF	675783	
3.70	RSH40370EX	RSH40370CF	675784	
3.90	RSH40390EX	RSH40390CF	675785	
4.11	RSH40411EX	RSH40411CF	675786	
4.33	RSH40433EX	RSH40433CF	675787	

*Note 1: The D/R454 family of axles were originally replaced by tandem models: DSH40/RSH40 or DSH44/RSH44 depending on select ratios. The carriers and ratios above are the High Performance, Large Ring Gear service carriers. For all other ratios not shown are now directly serviced by the DSP/RSP40 models, refer to those carrier listings and also see Dana bulletin abib-0902.*

## DSH40P - HIGH PERFORMANCE CARRIER W/ PUMP OPTION

Spline: 41 Involute  
 Gearing: 15.75" Hypoid  
 Side Gear Part Number: 127368  
 Fastener Kit: 512087

*These new carrier units will directly replace models DSH40P and DS454P with no modifications. See Note 1.*

Ratio	New Carrier Exchange	New Carrier Core Free	Old Carrier Part - NLA	Notes
3.25	DSH40P325EX	DSH40P325CF	682751	
3.36	DSH40P336EX	DSH40P336CF	682752	
3.55	DSH40P355EX	DSH40P355CF	682753	
3.70	DSH40P370EX	DSH40P370CF	682754	
3.90	DSH40P390EX	DSH40P390CF	682755	
4.11	DSH40P411EX	DSH40P411CF	682756	
4.33	DSH40P433EX	DSH40P433CF	682757	

*Note 1: The D/R454P family of axles were originally replaced by tandem models: DSH40P/RSH40P or DSH44P/RSH44P depending on select ratios. The carriers and ratios above are the High Performance, Large Ring Gear service carriers. For all other ratios not shown are now directly serviced by the DSP/RSP40P models, refer to those carrier listings and also see Dana bulletin abib-0902.*

## 22060SH / 23060SH - HIGH PERFORMANCE CARRIER

Spline: 41 Involute  
 Gearing: 15.40-15.75" Hypoid  
 Side Gear Part Number: 127368  
 Fastener Kit: 512087

*See Note 1. The new carrier units below will directly replace models 22060SH in ratios 3.08 thru 7.17 Some carrier models used in Single Axle applications are labeled differently for service-versus the same carrier used in other Rear Rear Tandem axle applications (ie 22060SH is the same as RSP40 / RSH40 / RSH44).*

Ratio	New Carrier Exchange	New Carrier Core Free	Old Carrier Part - NLA	Notes
3.08	RSP40308EX	RSP40308CF	676031	
3.25	RSH40325EX	RSH40325CF	675781	
3.36	RSH40336EX	RSH40336CF	675782	
3.55	RSH40355EX	RSH40355CF	675783	
3.70	RSH40370EX	RSH40370CF	675784	
3.90	RSH40390EX	RSH40390CF	675785	
4.11	RSH40411EX	RSH40411CF	675786	
4.33	RSH40433EX	RSH40433CF	675787	
4.63	RSP40463EX	RSP40463CF	676039	
4.88	RSP40488EX	RSP40488CF	676040	
5.29	RSP40529EX	RSP40529CF	676041	
5.57	RSP40557EX	RSP40557CF	676042	
6.17	RSP40617EX	RSP40617CF	676043	
6.50	RSP40650EX	RSP40650CF	676044	
7.17	RSP40717EX	RSP40717CF	681443	

*Note 1: Dana carriers are application specific. Some motor coach and bus applications require Gentech gearing. When doing repairs or replacement of these axles, be sure to consult the OEM or verify the actual part numbers from the serial tags before ordering replacement carriers.*

**22060SH - HIGH PERFORMANCE CARRIER W/ NO SPIN OPTION**

Spline: 41 Involute  
 Gearing: 15.75" Hypoid  
 No Spin Diff Part Number: 128776  
 Fastener Kit: 512087 for thick flange carriers

See Note 1. The RSH44 new carrier units will directly replace models 22060SH in ratios 4.88 thru 7.17 Some carrier models used in Single Axle applications are labeled differently for service-versus the same carrier used in other Rear Rear Tandem axle applications (ie 22060SH is the same as RSH40 / RSH44).

Ratio	New Carrier Exchange	New Carrier Core Free	Old Carrier Part - NLA	Notes
4.88	RSH44N488EX	RSH44N488CF	681609	
5.29	RSH44N529EX	RSH44N529CF	681610	
5.57	RSH44N557EX	RSH44N557CF	681611	
6.17	RSH44N617EX	RSH44N617CF	681612	
6.50	RSH44N650EX	RSH44N650CF	681613	
7.17	RSH44N717EX	RSH44N717CF	681614	

Note 1: Dana carriers are application specific. Some motor coach and bus applications require Gentech gearing. When doing repairs or replacement of these axles, be sure to consult the OEM or verify the actual part numbers from the serial tags before ordering replacement carriers.

**DDH40 - DIFF LOCK - HIGH PERFORMANCE CARRIER**

Spline: 41 Involute  
 Gearing: 15.75" Hypoid  
 Side Gear Part Number: 127368  
 Fastener Kit: 512087

These new carrier units will directly replace models DDH40 and DD454 with no modifications. See Note 1.

Ratio	New Carrier Exchange	New Carrier Core Free	Old Carrier Part - NLA	Notes
3.25	DDH40325EX	DDH40325CF	682761	
3.36	DDH40336EX	DDH40336CF	682762	
3.55	DDH40355EX	DDH40355CF	682763	
3.70	DDH40370EX	DDH40370CF	682764	
3.90	DDH40390EX	DDH40390CF	682765	
4.11	DDH40411EX	DDH40411CF	682766	
4.33	DDH40433EX	DDH40433CF	682767	

Note 1: The D/R454 family of axles were originally replaced by tandem models: DSH40/RSH40 or DSH44/RSH44 depending on select ratios. The carriers and ratios above are the High Performance, Large Ring Gear service carriers. For all other ratios not shown are now directly serviced by the DSP/RSP40 models, refer to those carrier listings and also see Dana bulletin abib-0902.

**DDH40P - DIFF LOCK - HIGH PERFORMANCE CARRIER W/ PUMP OPTION**

Spline: 41 Involute  
 Gearing: 15.75" Hypoid  
 Side Gear Part Number: 127368  
 Fastener Kit: 512087

These new carrier units will directly replace models DDH40P and DD454P with no modifications. See Note 1.

Ratio	New Carrier Exchange	New Carrier Core Free	Old Carrier Part - NLA	Notes
3.25	DDH40P325EX	DDH40P325CF	682771	
3.36	DDH40P336EX	DDH40P336CF	682772	
3.55	DDH40P355EX	DDH40P355CF	682773	
3.70	DDH40P370EX	DDH40P370CF	682774	
3.90	DDH40P390EX	DDH40P390CF	682775	
4.11	DDH40P411EX	DDH40P411CF	682776	
4.33	DDH40P433EX	DDH40P433CF	682777	

Note 1: The D/R454P family of axles were originally replaced by tandem models: DSH40P/RSH40P or DSH44P/RSH44P depending on select ratios. The carriers and ratios above are the High Performance, Large Ring Gear service carriers. For all other ratios not shown are now directly serviced by the DSP/RSP40P models, refer to those carrier listings and also see Dana bulletin abib-0902.

**RDH40 - DIFF LOCK - HIGH PERFORMANCE CARRIER**

Spline: 41 Involute  
 Gearing: 15.75" Hypoid  
 Side Gear Part Number: 127368  
 Fastener Kit: 512087

These new carrier units will directly replace model 23060DH, RDH40, RDH44 & RD454 with no modifications. See Note 1.

Ratio	New Carrier Exchange	New Carrier Core Free	Old Carrier Part - NLA	Notes
3.25	RDH40325EX	RDH40325CF	675791	
3.36	RDH40336EX	RDH40336CF	675792	
3.55	RDH40355EX	RDH40355CF	675793	
3.70	RDH40370EX	RDH40370CF	675794	
3.90	RDH40390EX	RDH40390CF	675795	
4.11	RDH40411EX	RDH40411CF	675796	
4.33	RDH40433EX	RDH40433CF	675797	

Note 1: The D/R454 family of axles were originally replaced by tandem models: DSH40/RSH40 or DSH44/RSH44 depending on select ratios. The carriers and ratios above are the High Performance, Large Ring Gear service carriers. For all other ratios not shown are now directly serviced by the DSP/RSP40 models, refer to those carrier listings and also see Dana bulletin abib-0902.

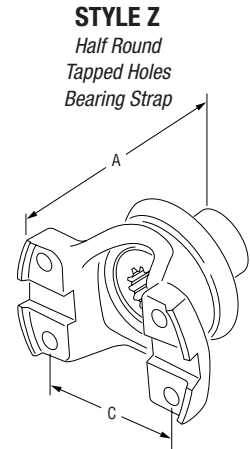
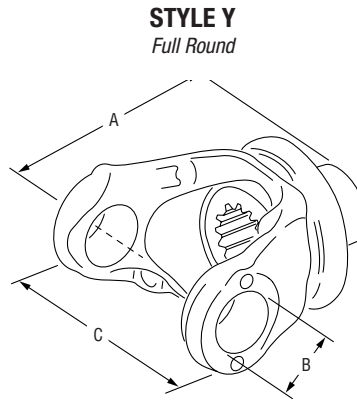
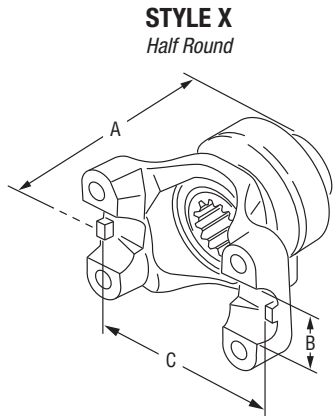

## All DSP40, DSP41, DSH40, DSH44 Forward Tandem Axle Models

### FORWARD AXLE - INPUT POSITION 1 / 2.274-44 INVOLUTE SPLINE

Slinger #232511

End Yoke Assy (includes slinger)	Series	Style	Dimensions (in Inches):				Replaces Old Part #
			Bearing Cap Diameter	Yoke Span	Centerline to End	Ground Hub Diameter	
6-4-8981-1X	1710	HR	1.938	6.190	5.190	3.000	127617
6-4-8981-1X	1710	HR	1.938	6.190	5.190	3.000	127617
6.3-4-5221X	1760	BP	1.938	7.000	5.250	3.000	127618
6.5-4-4571X	1810	BP	1.938	7.547	5.250	3.000	127619
6.5-4-4571-1X	1810	HR	1.938	7.643	5.250	3.000	127621
6.3-4-5221-1X	1760	HR	1.938	7.094	5.250	3.000	127622
170-4-201-1X	SPL170	HR	2.166	6.456	5.270	3.000	210831
250-4-81-1X	SPL250	HR	2.166	6.412	5.490	3.000	210833

### FORWARD AXLE - OUTPUT POSITION 2 / 2.024-39 INVOLUTE SPLINE

Slinger #232514

End Yoke Assy (includes slinger)	Series	Style	Dimensions (in Inches):				Replaces Old Part #
			Bearing Cap Diameter	Yoke Span	Centerline to End	Ground Hub Diameter	
6-4-9041X	1710	BP	1.938	6.094	5.250	2.625	127558
6-4-9001X	1710	BP	1.938	6.094	6.125	2.625	127624
6-4-9001-1X	1710	HR	1.938	6.190	6.125	2.625	128722
6-4-9041-1X	1710	HR	1.938	6.190	5.250	2.625	128737
170-4-221-1X	SPL170	HR	2.166	6.456	5.266	2.625	210835
170-4-241-1X	SPL170	HR	2.166	6.456	6.500	2.625	210837

## Yokes - Tandem Axle: All RSP40, RSP41, RSH40, RSH44 Rear Models

### REAR AXLE - PINION POSITION 3 / 2.024-39 INVOLUTE SPLINE

Slinger #232511

End Yoke Assy (includes slinger)	Series	Style	Dimensions (in Inches):				Replaces Old Part #
			Bearing Cap Diameter	Yoke Span	Centerline to End	Ground Hub Diameter	
6-4-9031X	1710	BP	1.938	6.094	5.250	3.000	127415
6-4-8991X	1710	BP	1.938	6.094	6.125	3.000	127637
5-4-8261	1610	BP	1.875	5.312	6.00	3.00	128720
6-4-9031-1X	1710	HR	1.938	6.190	5.250	3.000	128745
6-4-8991-1X	1710	HR	1.938	6.190	6.125	3.000	128746
5-4-9241-1X	1610	HR	1.875	5.312	6.000	3.000	129019
5-4-9231-1X	1610	HR	1.875	5.312	4.875	3.000	129043
3-4-13081-1X	1480	HR	1.375	4.188	4.344	3.000	129164
4-4-7571-1X	1550	HR	1.375	4.964	4.281	3.000	129166
170-4-261-1X	SPL170	HR	2.166	6.456	5.156	3.000	210839
170-4-281-1X	SPL170	HR	2.166	6.456	6.240	3.000	210841
90-4-251-1X	SPL90	HR	1.625	4.957	4.750	3.000	210923

This kit contains installation tools used for installing drive axle oil seals. Using these tools ensures proper installation of the seal. Failure to use these tools may result in an improperly installed or damaged seal.

## Oil Seal Driver Installation Kit 217414

### D-INPUT

Use 126917

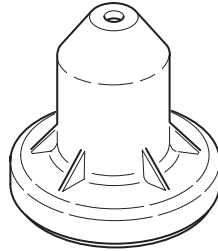

**126917**

### D-OUTPUT

Use 126917 and 128706

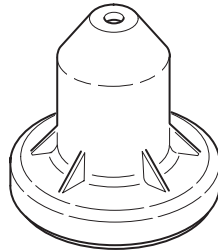

**126917**

+

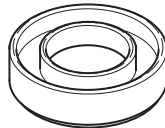

**128706**

### R-PINION

Use 126917

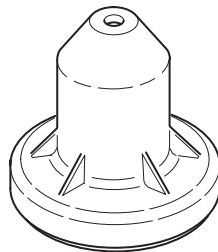

**126917**

Axle Housing Hardware Kit - Thick Flange Carriers	512087	Output Shaft Kit - All D Models	216227
Axle Housing Hardware Kit - Thin Flange Carriers	511600		
Axle Housing Hardware Kit - 22/23060SH/DH Carriers	514260		
Basic Overhaul Kit - DS Models BEFORE June 2008	510393	Pinion Brg Spacer Kit - All D Models	504043
Basic Overhaul Kit - DD Models BEFORE June 2008	510399	Pinion Brg Spacer Kit - All R Models	504016
Basic Overhaul Kit - DS Models AFTER June 2008	504030		
Basic Overhaul Kit - DD Models AFTER June 2008	504031		
Basic Overhaul Kit - RS Models	510398	Pinion Brg Cage Shim Kit - All D/R models	504032
Basic Overhaul Kit - RD Models	510400		
Bearing Kit - DS Models BEFORE June 2008	512812	Helical Gear Assy	130907
Bearing Kit - DD Models BEFORE June 2008	512800		
Bearing Kit - DS/DD Models AFTER June 2008	not available		
Bearing Kit - RS Models	512806		
Bearing Kit - RD Models	512805	Power Divider Cover	130823
Carrier Rebuild Kit DS Models BEFORE June 18 2008	504161	Power Divider Kit - Major - All Models BEFORE June 2008	504404-2
Carrier Rebuild Kit DS Models AFTER June 18 2008	504033	Power Divider Kit - Major - Pump Models AFTER June 2008	504404-4
Carrier Rebuild Kit DD Models AFTER June 18 2008	504034	Power Divider Kit - Major - Non-Pump Models AFTER June 2008	504404-6
Cage & Cup Assy - All D Models	134316 <i>replaces 129767-nla</i>	Power Divider Kit - Minor - All Models BEFORE June 2008	504404-1
Cage & Cup Assy - All R Models - Standard	10002988 <i>replaces 129768-nla</i>	Power Divider Kit - Minor - Pump Models AFTER June 2008	504404-3
Input Brg Cover Assy - D Models	129575 <i>replaces 129996-nla</i>	Power Divider Kit - Minor - Non-Pump Models AFTER June 2008	504404-5
Input Shaft Kit - All "D" Models - BEFORE June 2008	504181	Ring Gear Nut & Bolt Kit - All D/R Models	508652
Input Shaft Kit - D40K PUMP Models - AFTER June 2008	504027		
Input Shaft Kit - D40K NON-PUMP Models-AFTER June 2008	504026	Shift Fork & Spring Kit - All D Models	510870
Inter-Axle Diff Assy - All D Models	134192	Spindle Nut Kit - All Models	504158
		Wheel Diff Case Kit - 2.64 to 3.08 - All DS/RS Models	508653
Lube Pump Assembly - All Models BEFORE June 2008	127534	Wheel Diff Case Kit - 3.25 to 3.90 - All DS/RS Models	508654
Lube Pump Assembly - All Models AFTER June 2008	131368	Wheel Diff Case Kit - 4.11 to 4.88 - All DS/RS Models	508655
		Wheel Diff Case Kit - 5.29 to 7.17 - All DS/RS Models	508656
Manifold Parts Kit - Pump Mdls AFTER June 2008	504029	Wheel Diff Case Kit - 2.64 to 3.08 - All DD/RD Models	508724
		Wheel Diff Case Kit - 3.25 to 3.90 - All DD/RD Models	508725
		Wheel Diff Case Kit - 4.11 to 4.88 - All DD/RD Models	508726
		Wheel Diff Case Kit - 5.29 to 7.17 - All DD/RD Models	508727
Oil Seal Driver Case Kit - All Dana Models	SP1401	Wheel Diff Side Gear Kit - 41 Inv - All D/R Models	510397
Oil Seal Driver Installation Kit - All D/R Models	217414	Wheel Diff Kit - w/o side gears - All D/R Models	510396
Oil Seal & Shim Kit - All D Models	216224		
Oil Seal & Shim Kit - All R Models	216225		









# SPICER®



# SPICER® U-JOINTS OUTPERFORM THE COMPETITION



MORE THAN  
**2X**  
BETTER THAN  
THE CLOSEST  
COMPETITOR!



MORE THAN  
**5X**  
BETTER THAN  
THE CLOSEST  
COMPETITOR!



**U-Joint Kit Test Results**  
Average Cycles to Failure – Based on Samples Tested  
**FATIGUE TESTING ON 250 SERIES U-JOINTS**

**U-Joint Kit Test Results**  
Average Cycles to Failure – Based on Samples Tested  
**FATIGUE TESTING ON 1810 SERIES U-JOINTS**

## Tested and Proven. Spicer® U-Joints Outperform the Competition!

You can trust Spicer Life® Series (SPL®) and Spicer 10™ Series u-joints to provide optimal performance. Test results show in charts above how Spicer u-joints outperform the competition.

**Demand the best.... Demand genuine Spicer® u-joints!**

For additional information on Spicer products visit [www.SpicerParts.com](http://www.SpicerParts.com).  
For our e-catalog and parts locator, visit [www.DanaAftermarket.com](http://www.DanaAftermarket.com).



Copyright Dana Limited, 2017. All rights reserved. Dana Limited. The following trademarks are registered trademarks of Dana Limited: Spicer®, Spicer Life®, SPL®, and Spicer 10™ Series.



**Dana Aftermarket Group**

PO Box 1000  
Maumee, Ohio 43537

Warehouse Distributors: 1.800.621.8084  
OE Dealers: 1.877.777.5360

Product information: SpicerParts.com  
E-cat/parts locator: DanaAftermarket.com

**SPICER**<sup>®</sup>



AXIP-4440-112017 Printed in U.S.A.  
Copyright Dana Limited, 2017.  
All rights reserved. Dana Incorporated.

